

AIR CONDITIONING SYSTEMS

HYBRID
CITY MULTI



DATA BOOK

MODEL

CMB-WP-NU-AA

CMB-WP-NU-AB



CMB-WP-NU-AA, CMB-WP-NU-AB

1. SPECIFICATIONS	2
2. EXTERNAL DIMENSIONS	6
3. CENTER OF GRAVITY	10
4. ELECTRICAL WIRING DIAGRAMS	11
5. SOUND LEVELS	15
5-1. Sound levels	15
5-2. NC curves	15
6. ELECTRICAL CHARACTERISTICS	16
7. SYSTEM DESIGN	17
7-1. Operation temperature range	17
7-2. Correction by piping length	19
7-3. Correction by antifreeze solution concentration	20
7-4. M-NET control	21
7-5. R410A piping material	22
7-6. Piping design	23

1. SPECIFICATIONS

HBC controller

HBC controller

Model				CMB-WP108NU-AA					
Number of branch				8					
Power source				1-phase 208-230 V					
				60 Hz					
Power input (208-230)	Cooling	kW	0.41-0.49						
	Heating	kW	0.41-0.49						
Current input (208-230)	Cooling	A	2.79-3.02						
	Heating	A	2.79-3.02						
Sound pressure level (measured in anechoic room) *20			dB <A>		43				
Applicable temperature range of installation site *21			D.B.		32 to 90°F (0 to 32°C)				
External finish				Galvanized steel plate (Drain pan: Pre-coated galvanized sheets + powder coating)					
Connectable outdoor/heat source unit model				PURY- (E)P72~168Y/TNU-A/A1 (-BS), PURY-P72~144ZKMU-A/B (-BS) PQRY-P72~168Y/T/ZLMU-A1					
Indoor unit capacity connectable to 1 branch				Model WL30 or smaller (Use optional joint pipe combining 2 branches when the total unit capacity exceeds WL30.)					
External dimension H × W × D			in.		11-13/16 x 59-7/8 x 24-13/16				
			mm		300 x 1,520 x 630				
Refrigerant piping diameter	*22 To outdoor/heat source unit		Connectable outdoor/heat source unit capacity						
			(E)P72	(E)P96	(E)P120	(E)P144~ (E)P168			
	High press. Pipe	in. (mm) O.D.	5/8 (15.88) Braze	3/4 (19.05) Braze	3/4 (19.05) Braze	7/8 (22.2) Braze			
	Low press. Pipe	in. (mm) O.D.	3/4 (19.05) Braze	7/8 (22.2) Braze	1-1/8 (28.58) Braze	1-1/8 (28.58) Braze			
To Main-HBC controller		in. (mm) O.D.	5/8 (15.88) Braze						
Water piping diameter									
Connection size	To Sub-HBC controller	Inlet/Outlet	mm O.D.				22		
	To Indoor unit	Inlet/Outlet	mm O.D.				22		
Field pipe size	To Sub-HBC controller	Total down-steam indoor unit capacity		WL06-36	WL37-72	WL73-108	WL109-144	WL145-180	WL181-200
		Inlet/Outlet	mm I.D. (Min)	20.0	25.8	30.0	33.3	36.2	36.8
To Indoor unit	Total down-steam indoor unit capacity		WL06-23			WL24-48			
	Inlet/Outlet	mm I.D. (Min)	20			30			
Field drain pipe size			in.		3/4 NPT				
Net weight			lbs (kg)		188 (85) [210 (95) with water]				
Standard attachment	Document		Installation Manual						
	Accessories		Wrench						
Optional parts				-					

- Notes:
- 1.Installation/foundation work, electrical connection work, duct work, insulation work, power source switch, and other items shall be referred to the Installation Manual.
 - 2.This unit is for R410A refrigerant.
 - 3.Install this unit in a location where noise (refrigerant noise) emitted by the unit will not disturb the neighbors.
(For use in quiet environments with low background noise, position the HBC controller at least 5 m away from any indoor units.)
 - 4.Please install the HBC controller in a place where noise will not be an issue.
 - 5.Please attach an expansion vessel (field supply).
 - 6.Please use copper or plastic pipes for the water circuit. Do not use steel or stainless steel pipework.
Furthermore, when using copper pipe-work use a non-oxidative brazing method.
Oxidation of the pipe-work will reduce the pump life.
 - 7.When brazing the pipes, be sure to braze, after covering a wet cloth to the insulation pipes of the units in order to prevent it from burning and shrinking by heat.
 - 8.Please install an air purge valve where air will gather in the water circuit.
 - 9.Please install a pressure reducing valve and a strainer on the water supply to the HBC controller.
 - 10.Please refer to the DATA BOOK or the Installation Manual for the specified water quality.
 - 11.This unit is not designed for outside installations.
 - 12.Please always make water circulate or pull out the circulation water completely when not using it.
*Please do not use it as a drinking water.
 - 13.Please do not use ground water and well water.
 - 14.The unit cannot be used when the outdoor temperature is outside the guaranteed operation range.
If the unit is used in such condition, the unit may not go into the Thermo-ON mode.
Guaranteed operation range: 23 to 126°F in cooling mode, -13 to 60°F in heating mode
(Continuous operation is not guaranteed in -13 to -4°F.)
 - 15.This product is not designed for preservation of food, animals, plants, precision equipment, or art objects.
To prevent quality loss, do not use the product for purposes other than what it is designed for.
 - 16.The ambient relative humidity of the HBC controller needs to be kept below 80%.
 - 17.Sound pressure level differs depending on the connected outdoor/heat source unit capacity or operation condition.
 - 18.The sound pressure level values were obtained in an anechoic room. Actual sound pressure level is usually greater than that measured in anechoic room due to ambient noise and deflection sound.
 - 19.Indoor unit capacity connectable to 1 branch is changed depending on the indoor unit type and connection method.
Please refer to the Installation Manual for more information.
 - 20.The sound pressure level measured by the conventional method in JIS for reference purpose.
 - 21.When installing the HBC controller in an environment which may drop below 32°F (0°C), please add antifreeze liquid to the circulating water. (Refer to the DATA BOOK and the Installation Manual).
 - 22.For the refrigerant pipe size, refer to Installation Manual of outdoor units/heat source units.

1. SPECIFICATIONS

Model		CMB-WP1016NU-AA							
Number of branch		16							
Power source		1-phase 208-230 V							
		60 Hz							
Power input (208-230)	Cooling	kW	0.41-0.49						
	Heating	kW	0.41-0.49						
Current input (208-230)	Cooling	A	2.79-3.02						
	Heating	A	2.79-3.02						
Sound pressure level (measured in anechoic room) *20		dB <A>	43						
Applicable temperature range of installation site *21		D.B.	32 to 90°F (0 to 32°C)						
External finish		Galvanized steel plate (Drain pan: Pre-coated galvanized sheets + powder coating)							
Connectable outdoor/heat source unit model		PURY- (E)P72~168Y/TNU-A/A1 (-BS), PURY-P72~144ZKMU-A/B (-BS) PQRY-P72~168Y/T/ZLMU-A1							
Indoor unit capacity connectable to 1 branch		Model WL30 or smaller (Use optional joint pipe combining 2 branches when the total unit capacity exceeds WL30.)							
External dimension H × W × D		in.	11-13/16 x 70-7/8 x 24-13/16						
		mm	300 x 1,800 x 630						
Refrigerant piping diameter *22	To outdoor/heat source unit		Connectable outdoor/heat source unit capacity						
			(E)P72	(E)P96	(E)P120	(E)P144~(E)P168			
	High press. Pipe	in. (mm) O.D.	5/8 (15.88) Braze	3/4 (19.05) Braze	3/4 (19.05) Braze	7/8 (22.2) Braze			
	Low press. Pipe	in. (mm) O.D.	3/4 (19.05) Braze	7/8 (22.2) Braze	1-1/8 (28.58) Braze	1-1/8 (28.58) Braze			
To Main-HBC controller		in. (mm) O.D.	5/8 (15.88) Braze						
Water piping diameter									
Connection size	To Sub-HBC controller	Inlet/Outlet	mm O.D.				22		
	To Indoor unit	Inlet/Outlet	mm O.D.				22		
Field pipe size	To Sub-HBC controller	Total down-steam indoor unit capacity		WL06-36	WL37-72	WL73-108	WL109-144	WL145-180	WL181-200
		Inlet/Outlet	mm I.D. (Min)	20.0	25.8	30.0	33.3	36.2	36.8
	To Indoor unit	Total down-steam indoor unit capacity		WL06-23			WL24-48		
		Inlet/Outlet	mm I.D. (Min)	20			30		
Field drain pipe size		in.	3/4 NPT						
Net weight		lbs (kg)	217 (98) [245 (111) with water]						
Standard attachment	Document	Installation Manual							
	Accessories	Wrench							
Optional parts		-							

- Notes:
- Installation/foundation work, electrical connection work, duct work, insulation work, power source switch, and other items shall be referred to the Installation Manual.
 - This unit is for R410A refrigerant.
 - Install this unit in a location where noise (refrigerant noise) emitted by the unit will not disturb the neighbors.
(For use in quiet environments with low background noise, position the HBC controller at least 5 m away from any indoor units.)
 - Please install the HBC controller in a place where noise will not be an issue.
 - Please attach an expansion vessel (field supply).
 - Please use copper or plastic pipes for the water circuit. Do not use steel or stainless steel pipework.
Furthermore, when using copper pipe-work use a non-oxidative brazing method.
Oxidation of the pipe-work will reduce the pump life.
 - When brazing the pipes, be sure to braze, after covering a wet cloth to the insulation pipes of the units in order to prevent it from burning and shrinking by heat.
 - Please install an air purge valve where air will gather in the water circuit.
 - Please install a pressure reducing valve and a strainer on the water supply to the HBC controller.
 - Please refer to the DATA BOOK or the Installation Manual for the specified water quality.
 - This unit is not designed for outside installations.
 - Please always make water circulate or pull out the circulation water completely when not using it.
*Please do not use it as a drinking water.
 - Please do not use ground water and well water.
 - The unit cannot be used when the outdoor temperature is outside the guaranteed operation range.
If the unit is used in such condition, the unit may not go into the Thermo-ON mode.
Guaranteed operation range: 23 to 126°F in cooling mode, -13 to 60°F in heating mode
(Continuous operation is not guaranteed in -13 to -4°F.)
 - This product is not designed for preservation of food, animals, plants, precision equipment, or art objects.
To prevent quality loss, do not use the product for purposes other than what it is designed for.
 - The ambient relative humidity of the HBC controller needs to be kept below 80%.
 - Sound pressure level differs depending on the connected outdoor/heat source unit capacity or operation condition.
 - The sound pressure level values were obtained in an anechoic room. Actual sound pressure level is usually greater than that measured in anechoic room due to ambient noise and deflection sound.
 - Indoor unit capacity connectable to 1 branch is changed depending on the indoor unit type and connection method.
Please refer to the Installation Manual for more information.
 - The sound pressure level measured by the conventional method in JIS for reference purpose.
 - When installing the HBC controller in an environment which may drop below 32°F (0°C), please add antifreeze liquid to the circulating water. (Refer to the DATA BOOK and the Installation Manual).
 - For the refrigerant pipe size, refer to Installation Manual of outdoor units/heat source units.

1. SPECIFICATIONS

HBC controller

HBC controller

Model		CMB-WP108NU-AB								
Number of branch		8								
Power source		1-phase 208-230 V								
		60 Hz								
Power input (208-230)	Cooling	kW	0.01-0.01							
	Heating	kW	0.01-0.01							
Current input (208-230)	Cooling	A	0.07-0.07							
	Heating	A	0.07-0.07							
Sound pressure level (measured in anechoic room)		dB <A>		-						
Applicable temperature range of installation site *18		D.B.		32 to 90°F (0 to 32°C)						
External finish		Galvanized steel plate (Drain pan: Pre-coated galvanized sheets + powder coating)								
Connectable outdoor/heat source unit model		-								
Indoor unit capacity connectable to 1 branch		Model WL30 or smaller (Use optional joint pipe combining 2 branches when the total unit capacity exceeds WL30.)								
External dimension H × W × D		in.		11-13/16 x 59-7/8 x 24-13/16						
		mm		300 x 1,520 x 630						
Water piping diameter										
Connection size	To Main-HBC controller	Inlet/Outlet	mm O.D.		22					
	To Indoor unit	Inlet/Outlet	mm O.D.		22					
Field pipe size	To Main-HBC controller	Total down-steam indoor unit capacity		WL06-36	WL37-72	WL73-108	WL109-144	WL145-180	WL181-200	
		Inlet/Outlet	mm I.D. (Min)	20.0	25.8	30.0	33.3	36.2	36.8	
	To Indoor unit	Total down-steam indoor unit capacity		WL06-23			WL24-48			
		Inlet/Outlet	mm I.D. (Min)	20			30			
Field drain pipe size		in.		3/4 NPT						
Net weight		lbs (kg)		98 (44) [109 (49) with water]						
Standard attachment	Document		Installation Manual							
	Accessories		-							
Optional parts		-								

Notes:

1. Installation/foundation work, electrical connection work, duct work, insulation work, power source switch, and other items shall be referred to the Installation Manual.
2. This unit is for water.
3. Install this unit in a location where noise (refrigerant noise) emitted by the unit will not disturb the neighbors.
(For use in quiet environments with low background noise, position the Sub-HBC controller at least 5 m away from any indoor units.)
4. Please install the Sub-HBC controller in a place where noise will not be an issue.
5. Please attach an expansion vessel (field supply).
6. Please use copper or plastic pipes for the water circuit. Do not use steel or stainless steel pipework.
Furthermore, when using copper pipe-work use a non-oxidative brazing method.
Oxidation of the pipe-work will reduce the pump life.
7. When brazing the pipes, be sure to braze, after covering a wet cloth to the insulation pipes of the units in order to prevent it from burning and shrinking by heat.
8. Please install an air purge valve where air will gather in the water circuit.
9. Please refer to the DATA BOOK or the Installation Manual for the specified water quality.
10. This unit is not designed for outside installations.
11. Please always make water circulate or pull out the circulation water completely when not using it.
*Please do not use it as a drinking water.
12. Please do not use ground water and well water.
13. Can't use singleness. (Main-HBC controller is necessary)
14. The unit cannot be used when the outdoor temperature is outside the guaranteed operation range.
If the unit is used in such condition, the unit may not go into the Thermo-ON mode.
Guaranteed operation range: 23 to 126°F in cooling mode, -13 to 60°F in heating mode
(Continuous operation is not guaranteed in -13 to -4°F.)
15. This product is not designed for preservation of food, animals, plants, precision equipment, or art objects.
To prevent quality loss, do not use the product for purposes other than what it is designed for.
16. The ambient relative humidity of the HBC controller needs to be kept below 80%.
17. Indoor unit capacity connectable to 1 branch is changed depending on the indoor unit type and connection method.
Please refer to the Installation Manual for more information.
18. When installing the HBC controller in an environment which may drop below 32°F (0°C), please add antifreeze liquid to the circulating water. (Refer to the DATA BOOK and the Installation Manual).

1. SPECIFICATIONS

Model				CMB-WP1016NU-AB						
Number of branch				16						
Power source				1-phase 208-230 V						
				60 Hz						
Power input (208-230)	Cooling	kW	0.01-0.01							
	Heating	kW	0.01-0.01							
Current input (208-230)	Cooling	A	0.07-0.07							
	Heating	A	0.07-0.07							
Sound pressure level (measured in anechoic room)				dB <A>						
Applicable temperature range of installation site *18				D.B. 32 to 90°F (0 to 32°C)						
External finish				Galvanized steel plate (Drain pan: Pre-coated galvanized sheets + powder coating)						
Connectable outdoor/heat source unit model				-						
Indoor unit capacity connectable to 1 branch				Model WL30 or smaller (Use optional joint pipe combining 2 branches when the total unit capacity exceeds WL30.)						
External dimension H × W × D			in.	11-13/16 x 59-7/8 x 24-13/16						
			mm	300 x 1,520 x 630						
Water piping diameter										
Connection size	To Main-HBC controller	Inlet/Outlet	mm O.D.	22						
	To Indoor unit	Inlet/Outlet	mm O.D.	22						
Field pipe size	To Main-HBC controller	Total down-steam indoor unit capacity		WL06-36	WL37-72	WL73-108	WL109-144	WL145-180	WL181-200	
		Inlet/Outlet	mm I.D. (Min)	20.0	25.8	30.0	33.3	36.2	36.8	
	To Indoor unit	Total down-steam indoor unit capacity		WL06-23			WL24-48			
		Inlet/Outlet	mm I.D. (Min)	20			30			
Field drain pipe size			in.	3/4 NPT						
Net weight			lbs (kg)	115 (52) [135 (61) with water]						
Standard attachment	Document			Installation Manual						
	Accessories			-						
Optional parts				-						

Notes:

1. Installation/foundation work, electrical connection work, duct work, insulation work, power source switch, and other items shall be referred to the Installation Manual.
2. This unit is for water.
3. Install this unit in a location where noise (refrigerant noise) emitted by the unit will not disturb the neighbors.
(For use in quiet environments with low background noise, position the Sub-HBC controller at least 5 m away from any indoor units.)
4. Please install the Sub-HBC controller in a place where noise will not be an issue.
5. Please attach an expansion vessel (field supply).
6. Please use copper or plastic pipes for the water circuit. Do not use steel or stainless steel pipework.
Furthermore, when using copper pipe-work use a non-oxidative brazing method.
Oxidation of the pipe-work will reduce the pump life.
7. When brazing the pipes, be sure to braze, after covering a wet cloth to the insulation pipes of the units in order to prevent it from burning and shrinking by heat.
8. Please install an air purge valve where air will gather in the water circuit.
9. Please refer to the DATA BOOK or the Installation Manual for the specified water quality.
10. This unit is not designed for outside installations.
11. Please always make water circulate or pull out the circulation water completely when not using it.
*Please do not use it as a drinking water.
12. Please do not use ground water and well water.
13. Can't use singleness. (Main-HBC controller is necessary)
14. The unit cannot be used when the outdoor temperature is outside the guaranteed operation range.
If the unit is used in such condition, the unit may not go into the Thermo-ON mode.
Guaranteed operation range: 23 to 126°F in cooling mode, -13 to 60°F in heating mode
(Continuous operation is not guaranteed in -13 to -4°F.)
15. This product is not designed for preservation of food, animals, plants, precision equipment, or art objects.
To prevent quality loss, do not use the product for purposes other than what it is designed for.
16. The ambient relative humidity of the HBC controller needs to be kept below 80%.
17. Indoor unit capacity connectable to 1 branch is changed depending on the indoor unit type and connection method.
Please refer to the Installation Manual for more information.
18. When installing the HBC controller in an environment which may drop below 32°F (0°C), please add antifreeze liquid to the circulating water. (Refer to the DATA BOOK and the Installation Manual).

CMB-WP1016NU-AA

Unit: mm (in.)

<Accessory>
 -Wrench.....1pc.

- Note 1. Suspension bolt(φ10),washer(M10),and nut(M10) prepare in the field.
2. Take notice of service space as follows.
 (Please give attention not to occupy service space by letting ducts and pipes through.)
3. Refer to the DATA BOOK about connection pipe and drain pipe diameter size.
4. Refer to the Installation Manual for insulation of connection pipe and drain piping.
5. Refer to the Installation Manual for Installation of drain pan.
6. Do not place the HBC controller directly on the floor because the drain pan needs to be installed in a tilted position.

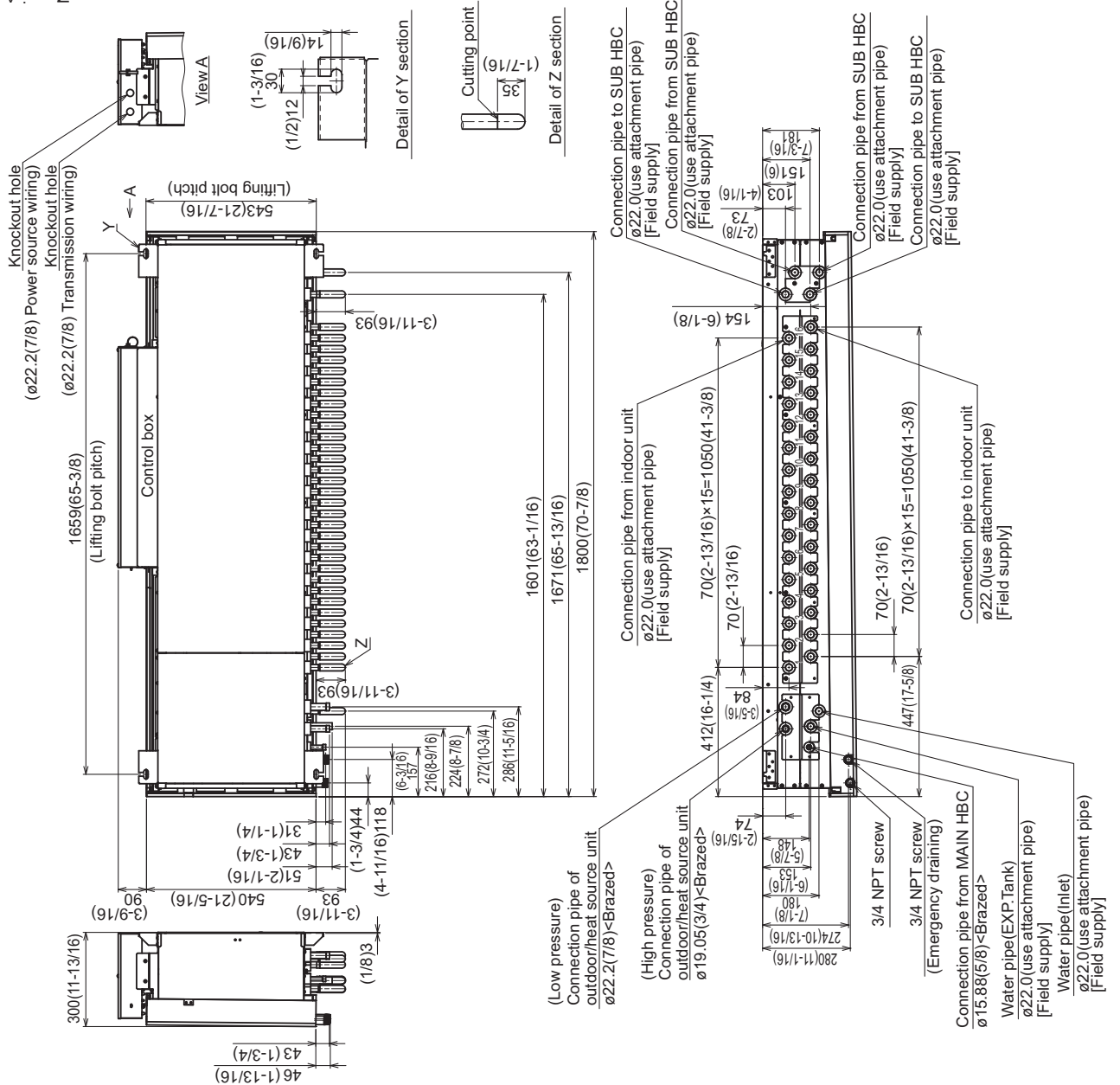

CMB-WP108NU-AB

Unit: mm (in.)

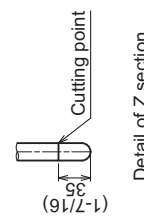
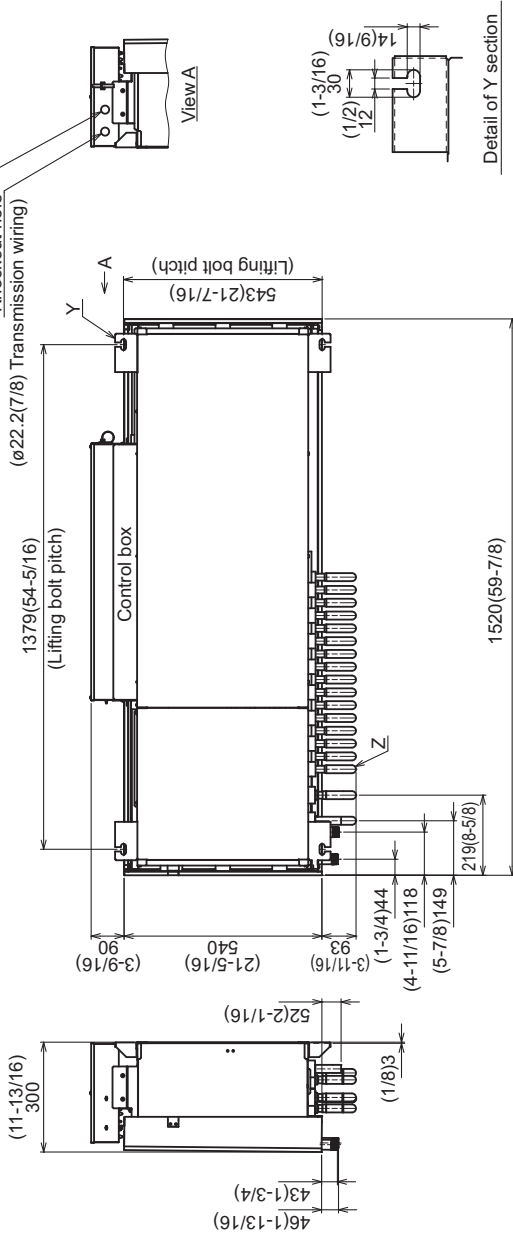

- Note 1. Suspension bolt($\phi 10$), washer(M10), and nut(M10) prepare in the field.
 2. Take notice of service space as follows.
 (Please give attention not to occupy service space by letting ducts and pipes through.)
 3. Refer to the DATA BOOK about connection pipe and drain pipe diameter size.
 4. Refer to the Installation Manual for insulation of connection pipe and drain piping.
 5. Refer to the Installation Manual for Installation of drain pan.
 6. Do not place the HBC controller directly on the floor because the drain pan needs to be installed in a tilted position.

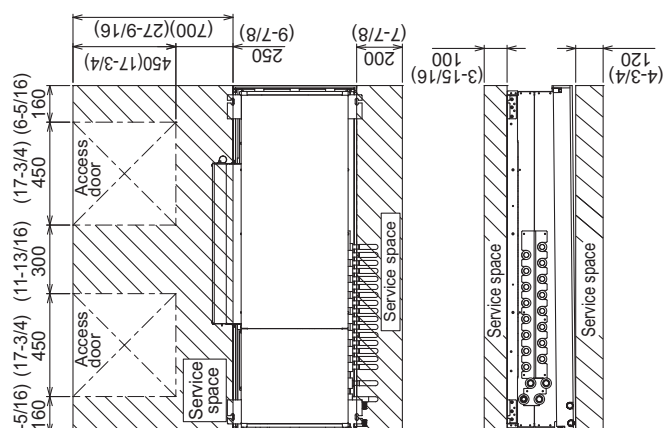
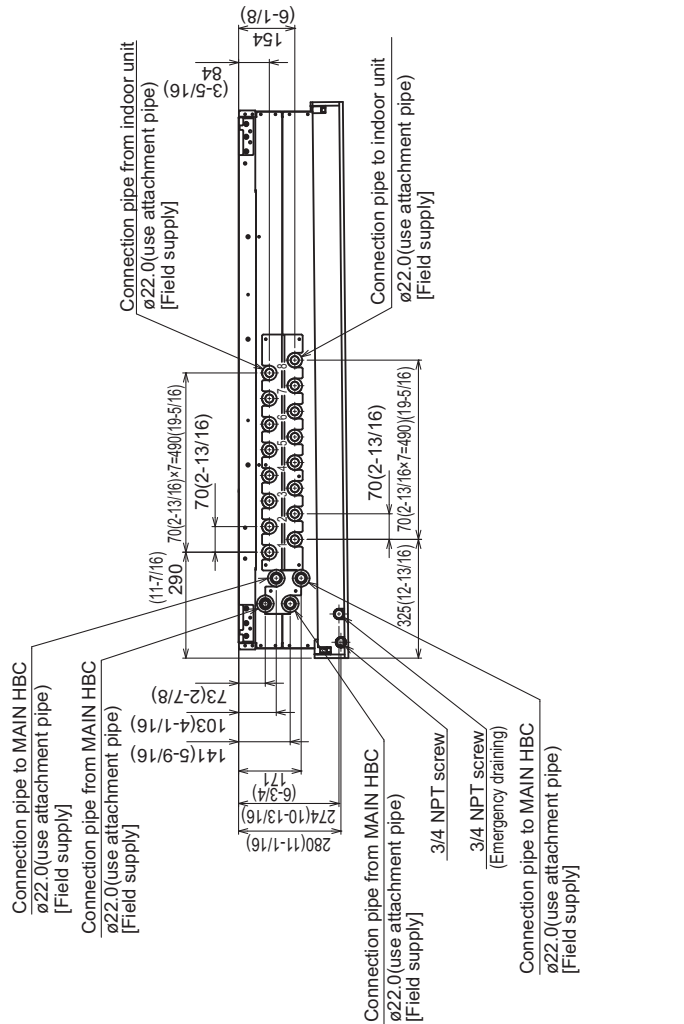

CMB-WP1016NU-AB

Unit: mm (in.)

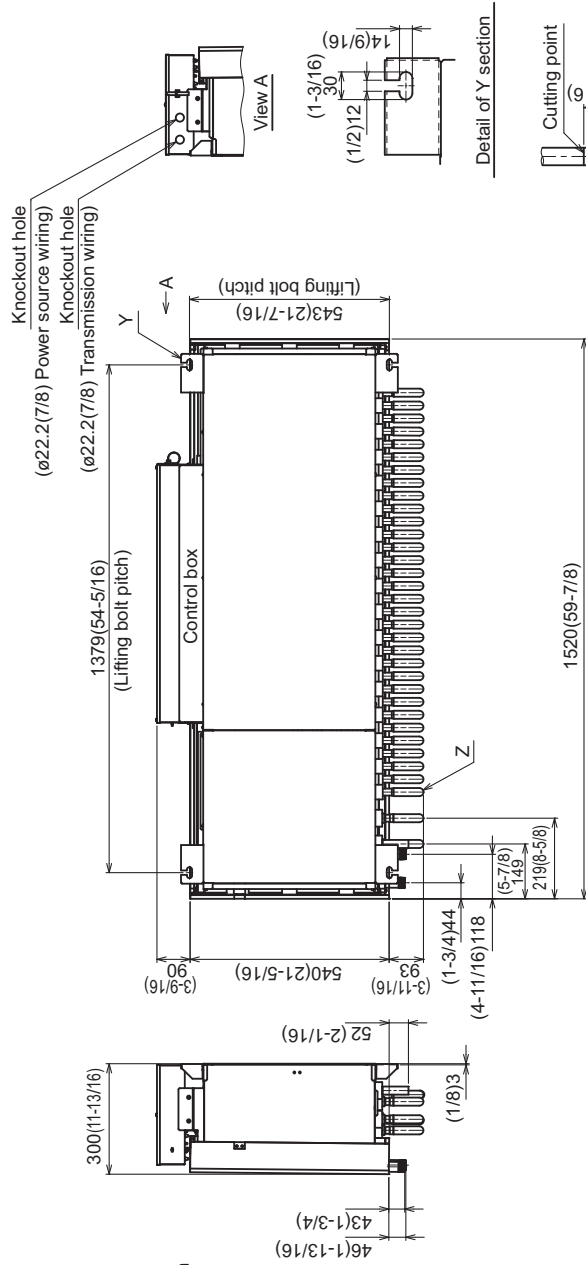

- Note 1. Suspension bolt(ø10), washer(M10), and nut(M10) prepare in the field.
 2. Take notice of service space as follows.
 (Please give attention not to occupy service space by letting ducts and pipes through.)
 3. Refer to the DATA BOOK about connection pipe and drain pipe diameter size.
 4. Refer to the Installation Manual for insulation of connection pipe and drain piping.
 5. Refer to the Installation Manual for Installation of drain pan.
 6. Do not place the HBC controller directly on the floor because the drain pan needs to be installed in a tilted position.

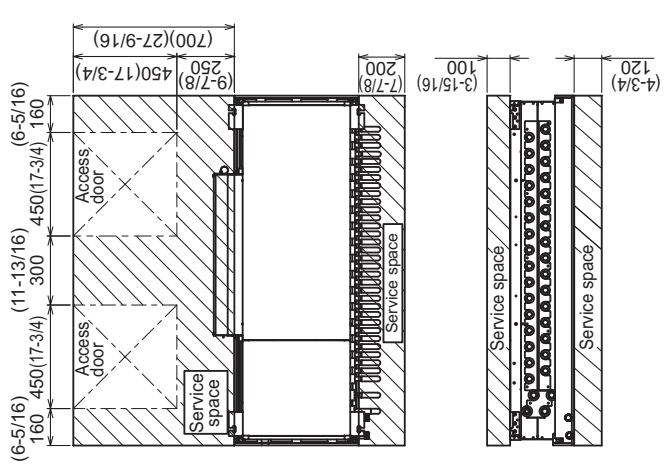
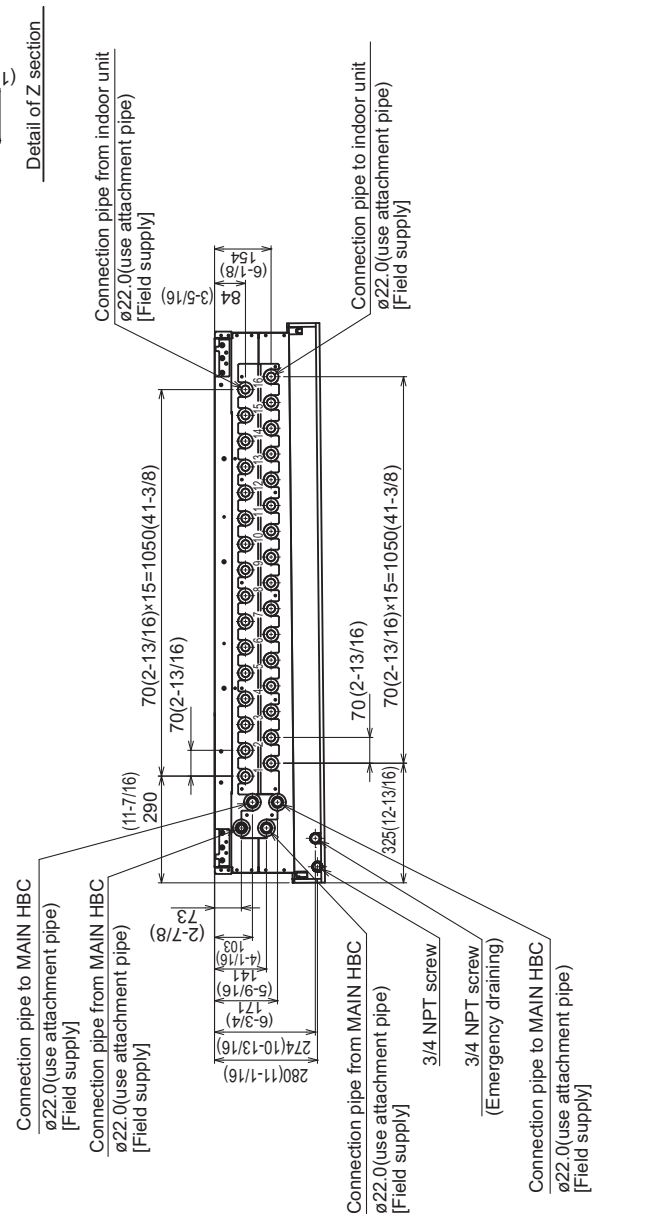

CMB-WP108, 1016NU-AA
 CMB-WP108, 1016NU-AB

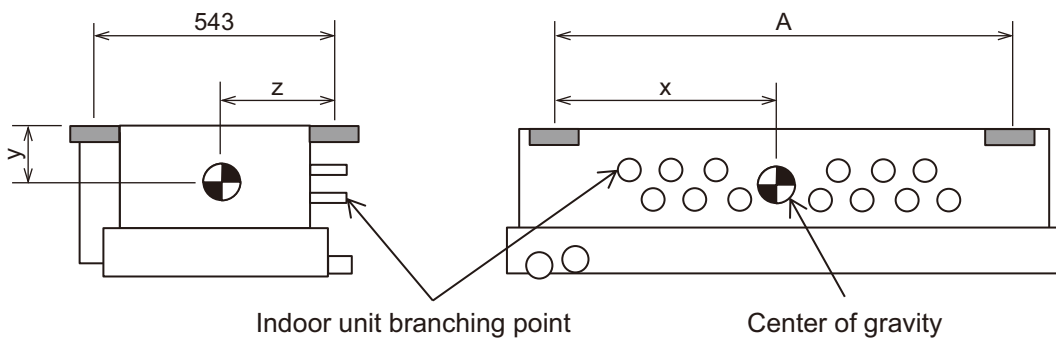

Unit: mm [in.]

	CMB-WP108NU-AA	CMB-WP1016NU-AA	CMB-WP108NU-AB	CMB-WP1016NU-AB
A	1379 [54-5/16]	1659 [65-6/16]	1379 [54-5/16]	1379 [54-5/16]
x	680 [26-13/16]	825 [32-8/16]	610 [24-1/16]	680 [26-13/16]
y	145 [5-12/16]	145 [5-12/16]	145 [5-12/16]	145 [5-12/16]
z	285 [11-4/16]	285 [11-4/16]	270 [10-11/16]	270 [10-11/16]

CMB-WP108NU-AA

(Symbol explanation)

Symbol	Name	Symbol	Name
ACL	AC reactor	SV1	Solenoid valve
TH11~16, TH32~35	Thermister sensor	FO01	Fuse AC250V 6.3A FH(TP)
TH31a~h	Expansion valve	21S4Ma, 21S4Mb	4 way valve
LEV1~3	Pressure sensor	WP1, WP2	Pump
FS1, PS3	Terminal block (for power source)	VB3a~h	Valve block
TB01	Terminal block (for transmission)	Z	Float switch
TB02	Terminal block (for transmission)		Function setting connector

- NOTE: 1. TB02 is transmission terminal block.
 2. Never connect power line to it.
 Control Board are as follows.
 SW1:0
 SW2:0
 3. The wirings to TB01 and TB02 shown in dotted line are field work.

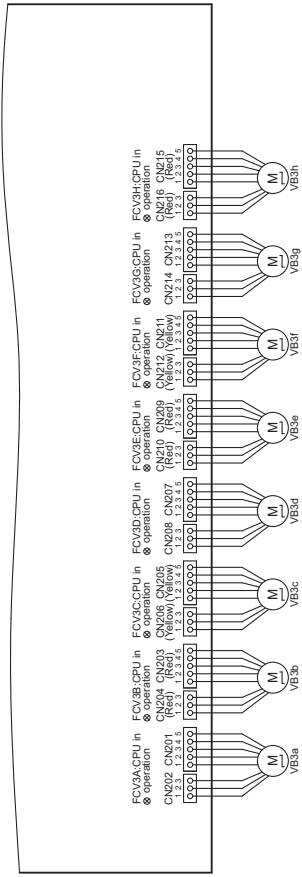
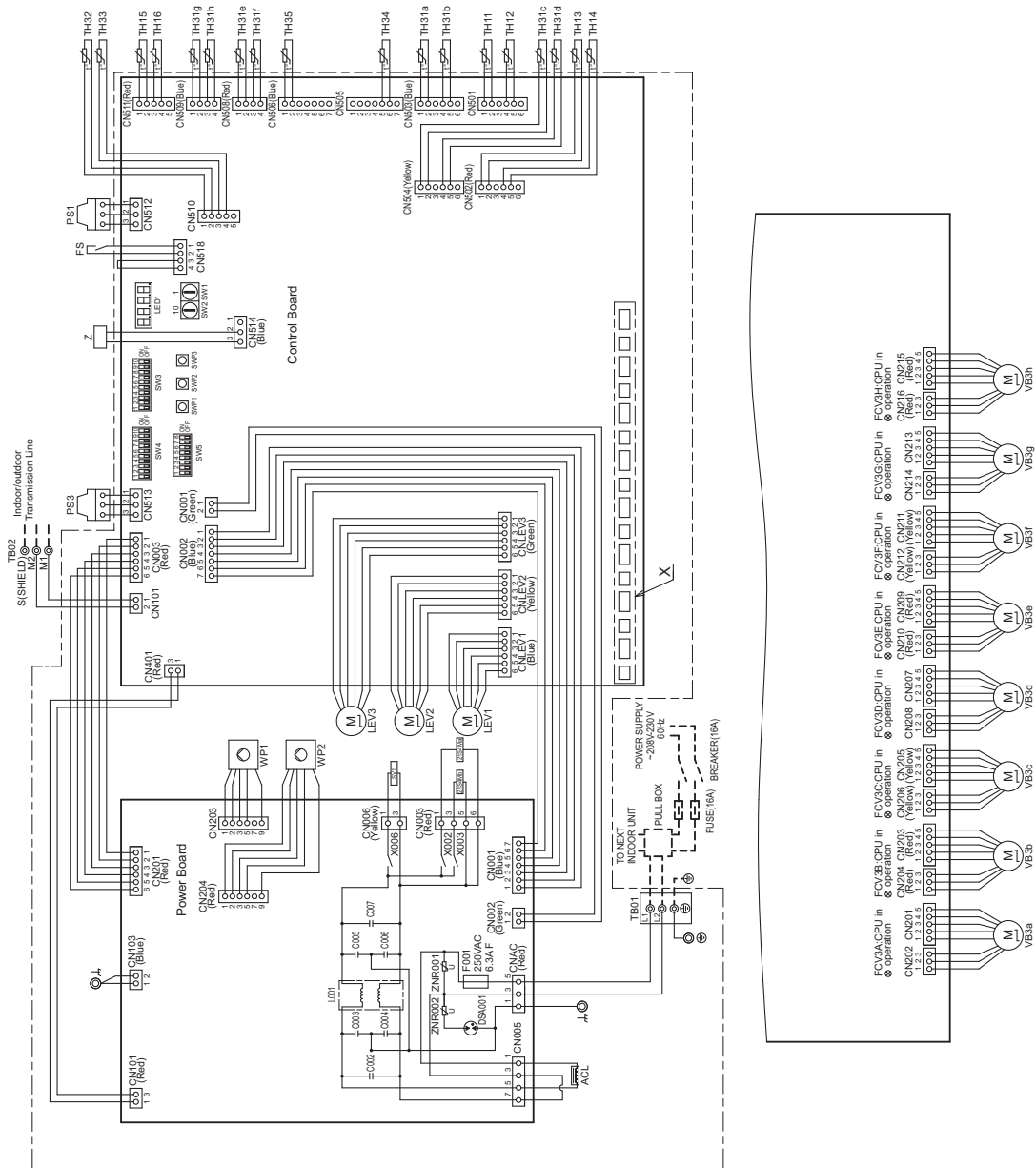

Detail of X section

CMB-WP1016NU-AA

Symbol	Name	Symbol	Name
ACL	AC reactor	SV1	Solenoid valve
TH1~16, TH32~35	Thermister sensor	F001	Fuse AC250V 6.3A FH(TP)
TH31a~p	Expansion valve	21SMA, 21SMB	4 way valve
LEV1~3	Pressure sensor	WP1, WP2	Pump
PS1, PS3	Terminal block (for power source)	VB3a~p	Valve block
TB01	Terminal block (for transmission)	FS	Floal switch
TB02	Terminal block (for transmission)	Z	Function setting connector

NOTE-1. TB02 is transmission terminal block.
 2. Never connect power line to it.
 Control Board are as follows.
 SW1:0
 SW2:0
 3. The wirings to TB01 and TB02 shown in dotted line are field work.

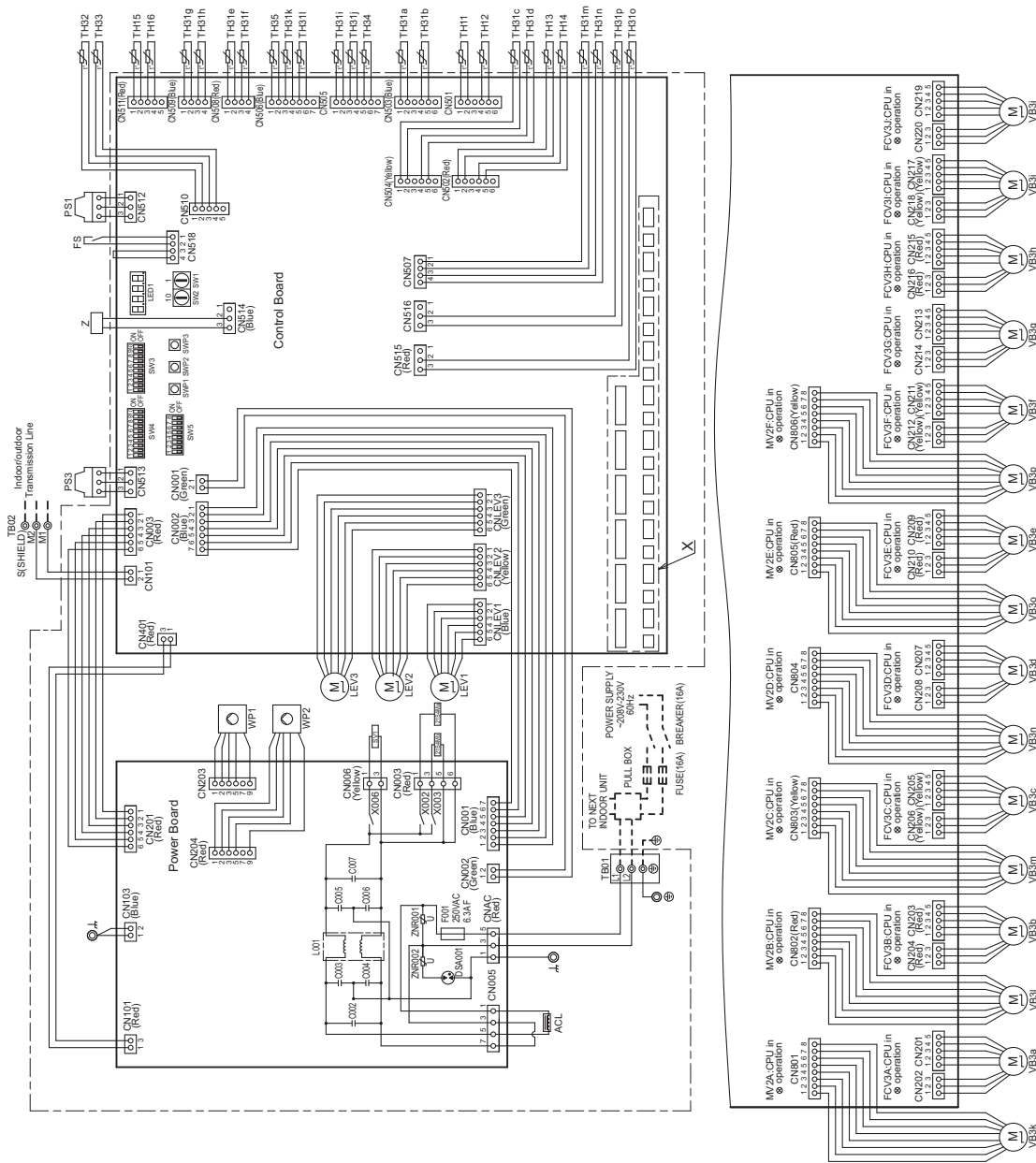

Detail of X section

CMB-WP108NU-AB

(Symbol explanation)

Symbol	Name
TH31a-h, TH32, TH33	Thermister sensor
VB3a-h	Valve block
FS	Floot switch
TB01	Terminal block (for power source)
TB02	Terminal block (for Transmission)
F001	Fuse AC250V 6.3A FH(TP)
Z	Function setting connector

NOTE:1. TB02 is transmission terminal block.
 Never connect power line to it.
 2. The initial set value of switch on Control Board are as follows.
 SW1:0
 SW2:0
 3. The wirings to TB01 and TB02 shown in dotted line are field work.

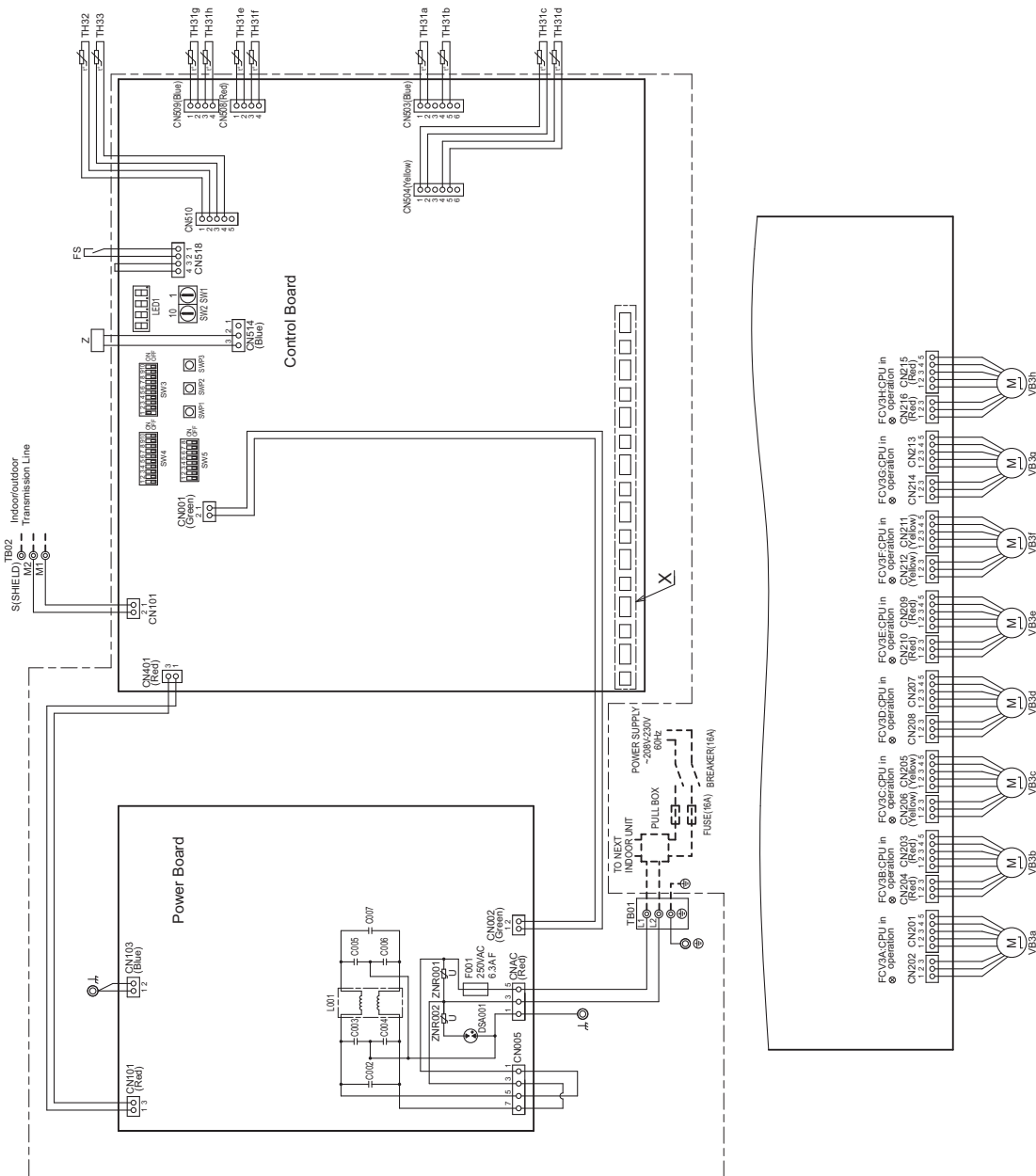

Detail of X section

CMB-WP1016NU-AB

Symbol	Name
TH31a-p, TH32, TH33	Thermister sensor
VB3a-p	Valve block
FS	Float switch
TB01	Terminal block (for power source)
TB02	Terminal block (for Transmission)
F001	Fuse AC250V 6.3A FHK(TP)
Z	Function setting connector

NOTE: 1. TB02 is transmission terminal block. Never connect power line to it.
 2. The initial set values of switch on Control Board are as follows.
 SW1:0
 SW2:0
 3. The wirings to TB01 and TB02 shown in dotted line are field work.

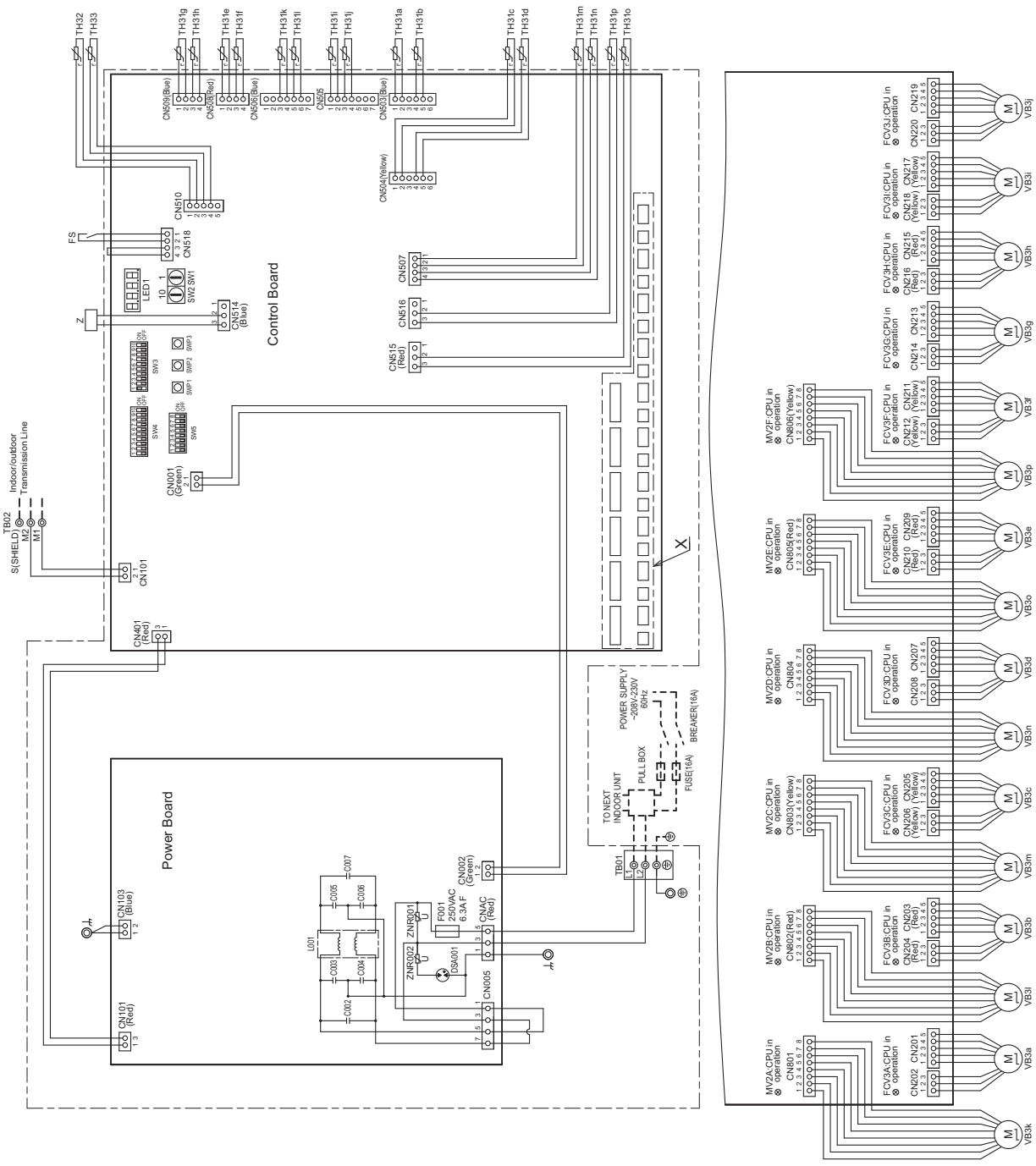

Detail of X section

5-1. Sound levels

(Measured point)

CMB-WP108NU-AA
CMB-WP1016NU-AA

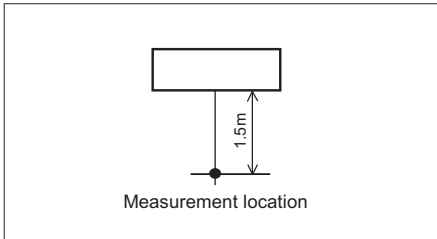

* Measured in anechoic room.

5-2. NC curves

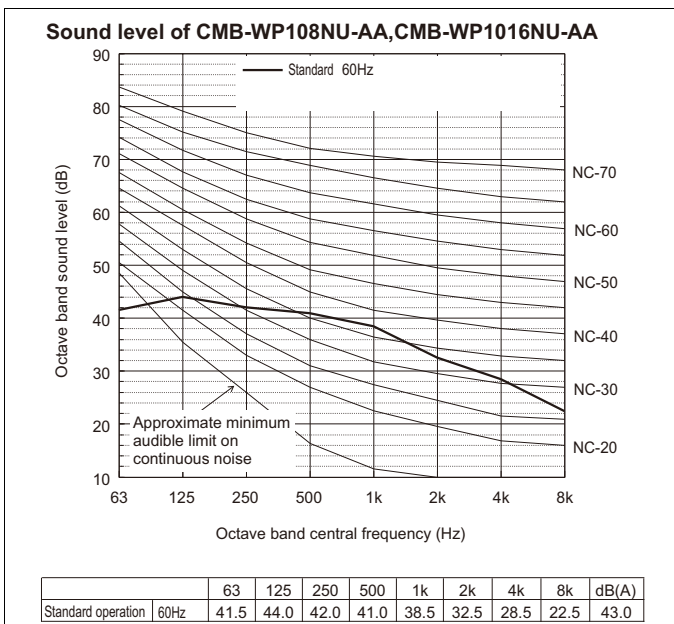

♦It is recommended to be installed in places such as ceilings of corridor, rest rooms and plant rooms.

6. ELECTRICAL CHARACTERISTICS

HBC controller

Symbols: MCA (Minimum Circuit Ampacity),
MOP (Maximum Overcurrent Protection), RLA (Rated Load Amps)

HBC controller	Power supply					RLA (A)
	Hz	Volts	Voltage range +-10%	MCA (A)	MOP (A)	
CMB-WP108NU-AA	60	208	Max.: 253V Min.: 188V	3.78	15	2.79
CMB-WP1016NU-AA		230				3.02
CMB-WP108NU-AB		208		0.09		0.07
CMB-WP1016NU-AB		230				0.07

HBC controller

7-1. Operation temperature range

7-1-1. Outdoor unit (PURY)

• Cooling

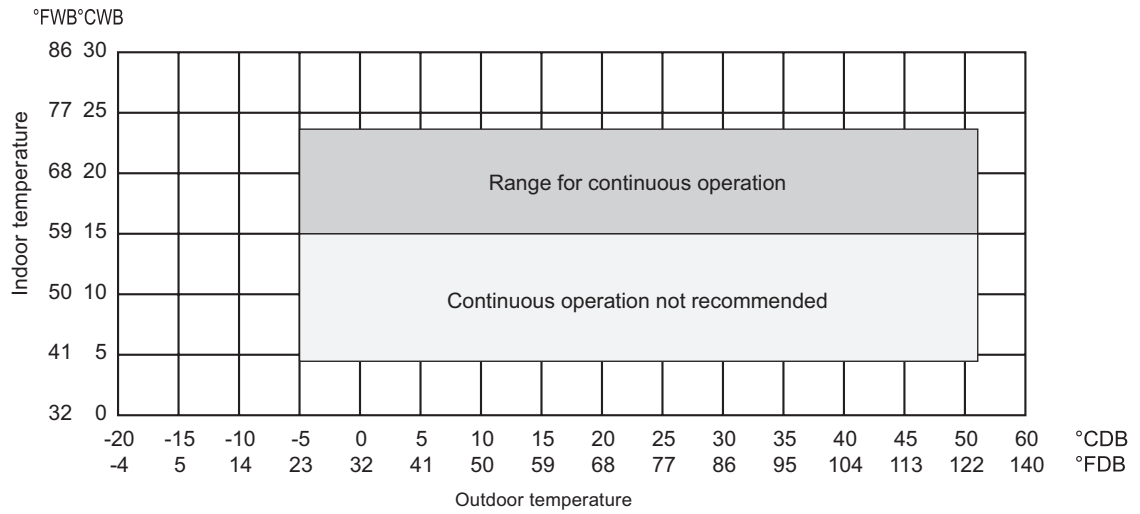

* The operation temperature of outdoor unit is limited into 32~109°FDB (0~43°CDB) when the outdoor unit is installed in a location that is positioned lower than the indoor units.

• Heating

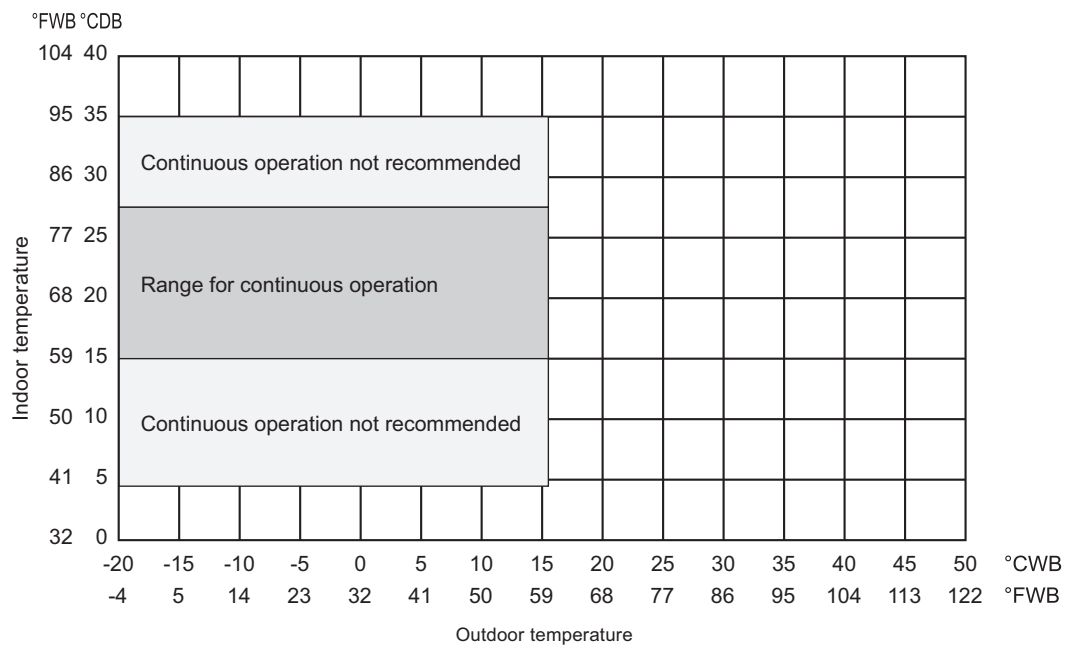

• Combination of cooling/heating operation (Cooling main or Heating main)

Outdoor temperature	Indoor temperature	
	Cooling	Heating
14 to 70°FDB (-10 to 21°CDB)	—	59 to 81°FDB (15 to 27°CDB)
12 to 60°FWB (-11 to 15.5°CWB)	59 to 75°FWB (15 to 24°CWB)	—

Installation of the low ambient kit is recommended to operate in cooling and cooling main mode in conditions under 50°F [10°C].

*1 When applying product below -4°F WB, consult your design engineer for cold climate application best practices, including the use of a backup source for heating.

*2 The unit cannot be used when the outdoor temperature is outside the guaranteed operation range. If the unit is used in such condition, the unit may not go into the Thermo-ON mode.

7-1-2. Heat source unit (PQRY)

Cooling

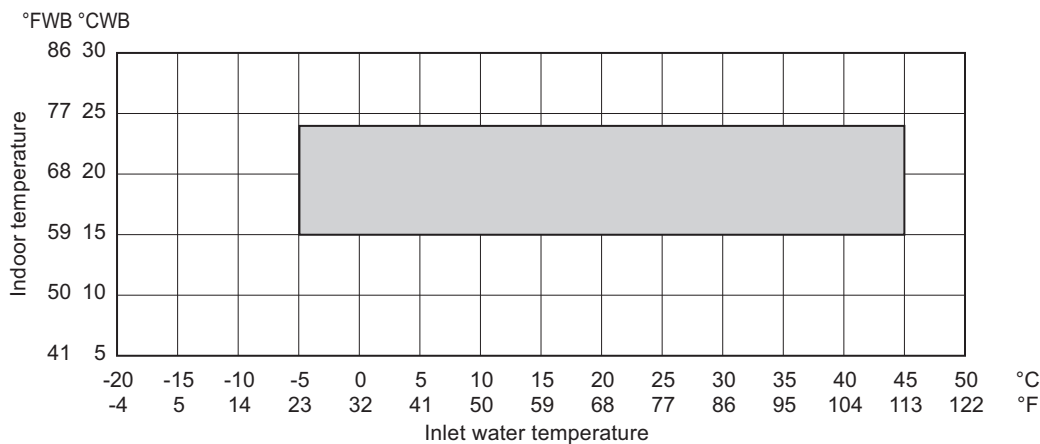

Heating

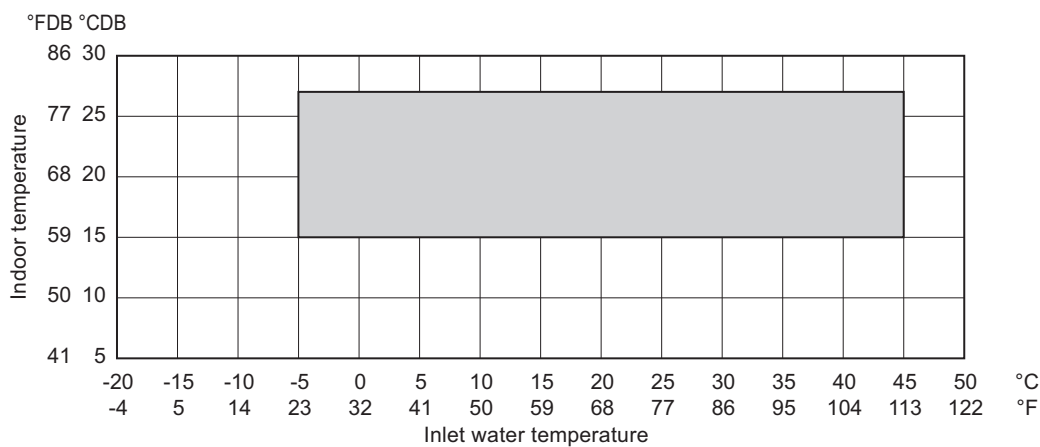

Combination of cooling/heating operation (Cooling main or Heating main)

Inlet water temperature	Indoor temperature	
	Cooling	Heating
-5 to 45°C (23 to 113°F)	15 to 24°CWB (59 to 75°FWB)	15 to 27°CDB (59 to 81°FDB)

* The upper limit of the outlet water temperature is approximately 70°C (158°F) when the circulating-water flow rate is within the normal range.

If the circulating-water flow rate goes outside the normal range, the outlet water temperature may exceed the above limit.

7-2. Correction by piping length

A decrease in cooling/heating capacity will occur due to piping length increase. The capacity can be calculated by using the correction factors according to the equivalent length of the piping.

- 7-2-1 and 7-2-2 show the correction factors for the water piping length.
- Refrigerant piping and water piping have separate correction factors.
- 7-2-3 shows how to obtain the equivalent length of water piping.
- Refer to the defrost correction factors described in outdoor unit's DATA BOOK for the outdoor unit's heating performance drop due to the frost at the outdoor heat exchanger and the automatic defrost operation.

* For the correction factors for the refrigerant piping length, refer to the outdoor unit's DATA BOOK.

7-2-1. Cooling capacity correction

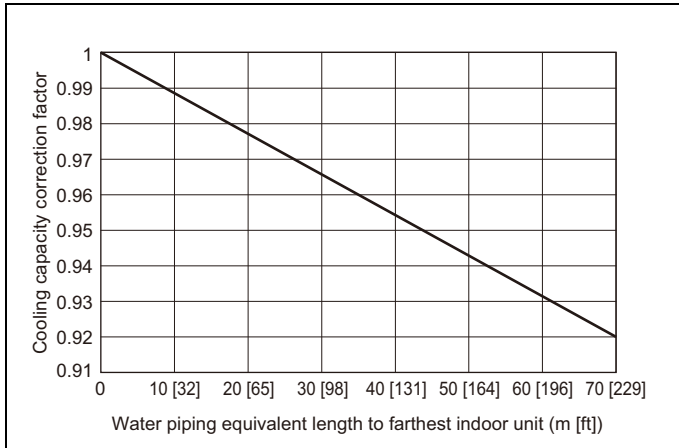

7-2-2. Heating capacity correction

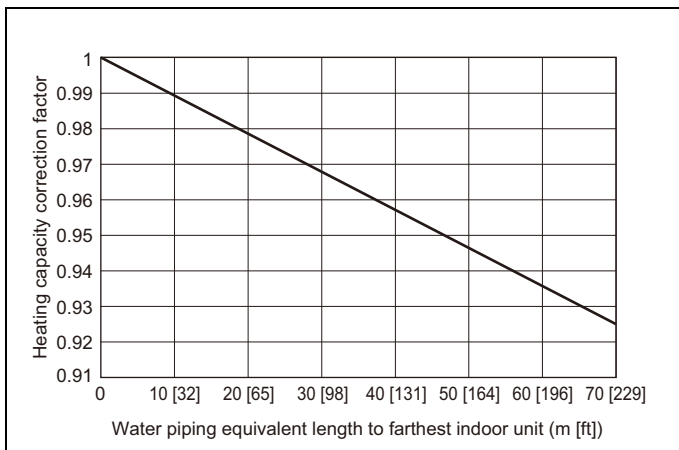

7-2-3. How to obtain the equivalent piping length

Water pipe

Equivalent length = (Actual piping length to the farthest indoor unit) + (0.55 × number of bends in the piping) [m]

Equivalent length = (Actual piping length to the farthest indoor unit) + (1.81 × number of bends in the piping) [ft]

7-3. Correction by antifreeze solution concentration

In HYBRID CITY MULTI system, antifreeze solution should be used to prevent the system from freezing. Refer to the following graphs for the capacity correction by antifreeze solution. Refer to 7-3-1 for antifreeze solution concentration, 7-3-2 and 7-3-3 for capacity correction by antifreeze solution concentration.

7-3-1. Antifreeze solution concentration

Use propylene glycol solution for antifreeze.

Refer to the following graph to estimate the antifreeze solution concentration required for freeze protection.

DipSW setting (SW5-4 and 5-5) is required in HBC controller depending on the antifreeze solution concentration.

Refer to Table A for the setting.

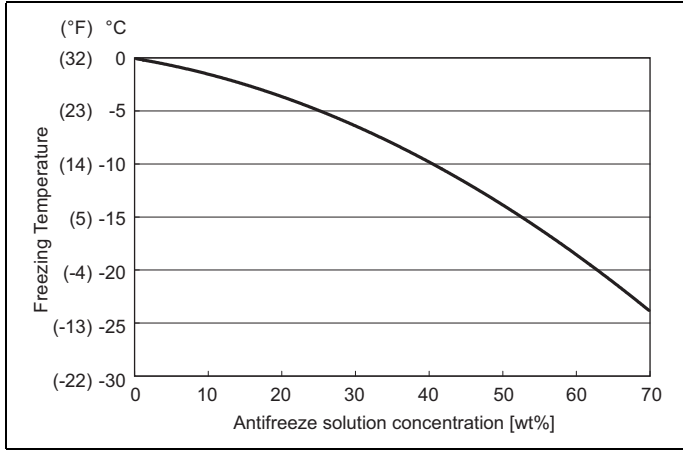
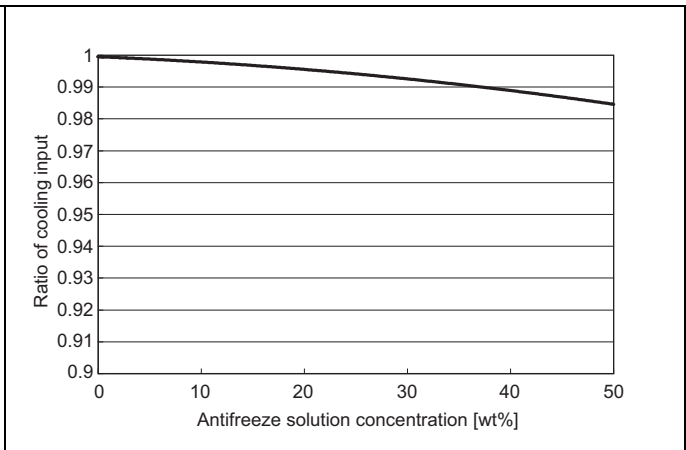
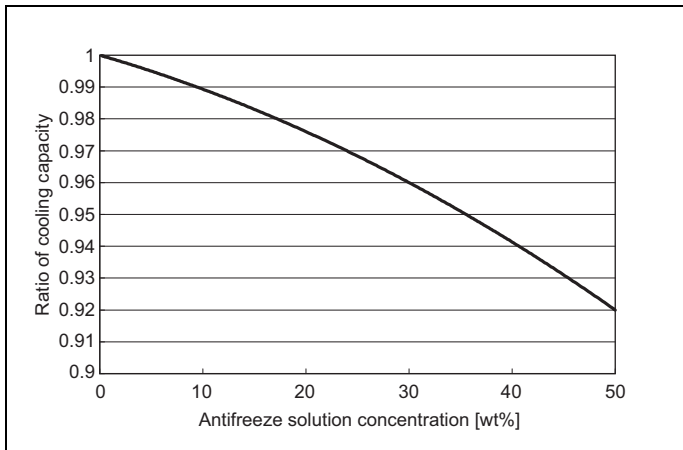

Table A

Brine concentration [%]	0 to 29%	30 to 49%	50 to 59%	60 to 70%	
DipSW5-4	OFF	OFF	ON	ON	
DipSW5-5	OFF	ON	OFF	ON	
7seg LED	LD2	OFF	OFF	1	1
	LD3	OFF	1	OFF	1

7-3-2. Capacity correction by antifreeze solution concentration (cooling)





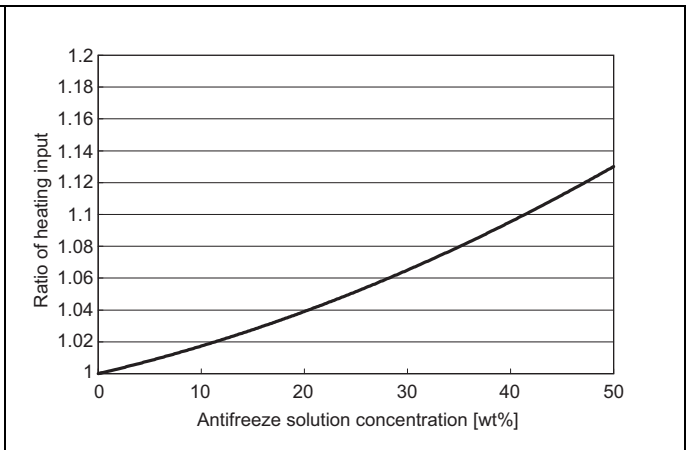
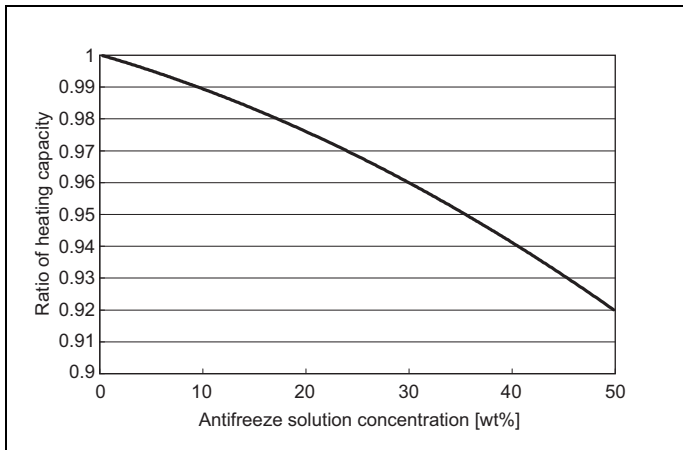





























7-3-3. Capacity correction by antifreeze solution concentration (heating)



7-4. M-NET control

7-4-1. Address setting

Unit		Address setting	Example	Note
Indoor unit		01 ~ 50	 	Use the most recent address within the same group of indoor units.
Outdoor unit		51 ~ 99, 100 (Note1)	 	The smallest address of indoor unit in same refrigerant system + 50 Assign sequential address numbers to the outdoor units in one refrigerant circuit system. OC, OS1 and OS2 are automatically detected. (Note 2) * Please reset one of them to an address between 51 and 99 when two addresses overlap. * The address automatically becomes "100" if it is set as "01~ 50"
HBC controller		52 ~ 99, 100	 	The address of the smallest address of indoor unit connected to the HBC controller +50 * Please reset one of them to an address between 51 and 99 when two addresses overlap. The address automatically becomes "100" if it is set as "01~ 50"
Local remote controller	ME, LOSSNAY Remote controller (Main)	101 ~ 150	1 Fixed  	The smallest address of indoor unit in the group + 100 * The place of "100" is fixed to "1"
	ME, LOSSNAY Remote controller (Sub)	151 ~ 199, 200	1 Fixed  	The address of main remote controller + 50 * The address automatically becomes "200" if it is set as "00"
System controller	ON/OFF remote controller	201 ~ 250	  	The smallest group No. to be managed + 200 * The smallest group No. to be managed is changeable.
	AE-200A/AE-50A AG-150A-A EB-50GU-A EW-50A TC-24B	000, 201 ~ 250	  	* TC-24B cannot be set to "000".
	PAC-YG50ECA	000, 201 ~ 250	  	* Settings are made on the initial screen of AG-150A.
	BAC-HD150	000, 201 ~ 250	  	* Settings are made with setting tool of BM ADAPTER.
PI, AI, DIDO	PAC-YG60MCA	01 ~ 50	 	
	PAC-YG63MCA	01 ~ 50	 	
	PAC-YG66DCA	01 ~ 50	 	
LOSSNAY		01 ~ 50	 	After setting the addresses of all the indoor units, assign an arbitrary address.
PAC-IF01AHC-J		201 ~ 250	2 Fixed  	

Note1: To set the address to "100", set it to "50"

Note2: Outdoor units OC and OS in one refrigerant circuit system are automatically detected.

OC and OS are ranked in descending order of capacity. If units are the same capacity, they are ranked in ascending order of their address.

7-5. R410A piping material

Refrigerant pipe for HYBRID CITY MULTI shall be made of phosphorus deoxidized copper, and has two types.

A. Type-O: Soft copper pipe (annealed copper pipe), can be easily bent with human's hand.

B. Type-1/2H pipe: Hard copper pipe (Straight pipe), being stronger than Type-O pipe of the same radical thickness.

The maximum operation pressure of R410A air conditioner is 4.30 MPa [623psi]. The refrigerant piping should ensure the safety under the maximum operation pressure. MITSUBISHI ELECTRIC recommends pipe size as Table 1, or You shall follow the local industrial standard. Pipes of radical thickness 0.7mm or less shall not be used.

Table 1. Copper pipe size and radial thickness for R410A HYBRID CITY MULTI.

Size (mm)	Size (in.)	Radial thickness (mm)	Radial thickness (mil)	Pipe type
ø6.35	ø1/4"	0.8	[32]	Type-O
ø9.52	ø3/8"	0.8	[32]	Type-O
ø12.7	ø1/2"	0.8	[32]	Type-O
ø15.88	ø5/8"	1.0	[40]	Type-O
ø19.05	ø3/4"	1.2	[48]	Type-O
ø19.05	ø3/4"	1.0	[40]	Type-1/2H or H
ø22.2	ø7/8"	1.0	[40]	Type-1/2H or H
ø25.4	ø1"	1.0	[40]	Type-1/2H or H
ø28.58	ø1-1/8"	1.0	[40]	Type-1/2H or H
ø31.75	ø1-1/4"	1.1	[44]	Type-1/2H or H
ø34.93	ø1-3/8"	1.2	[48]	Type-1/2H or H
ø41.28	ø1-5/8"	1.4	[56]	Type-1/2H or H

* For pipe sized ø19.05 (3/4") for R410A air conditioner, choice of pipe type is up to you.

* The figures in the radial thickness column are based on the Japanese standards and provided only as a reference. Use pipes that meet the local standards.

Flare

Due to the relative higher operation pressure of R410A compared to R22, the flare connection should follow dimensions mentioned below so as to achieve enough the air-tightness.

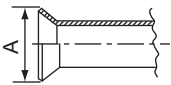
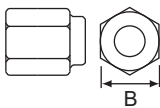
Flare pipe	Pipe size	A (For R410A)	(mm[in.])	Flare nut	Pipe size	B (For R410A)	(mm[in.])
	ø6.35 [1/4"]	9.1			ø6.35 [1/4"]	17.0	
	ø9.52 [3/8"]	13.2			ø9.52 [3/8"]	22.0	
	ø12.70 [1/2"]	16.6			ø12.70 [1/2"]	26.0	
	ø15.88 [5/8"]	19.7			ø15.88 [5/8"]	29.0	
	ø19.05 [3/4"]	24.0			ø19.05 [3/4"]	36.0	

7-6. Piping design

7-6-1. Restrictions on pipe length

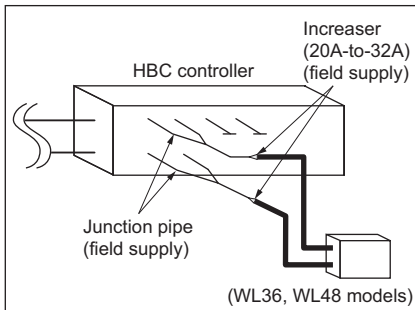
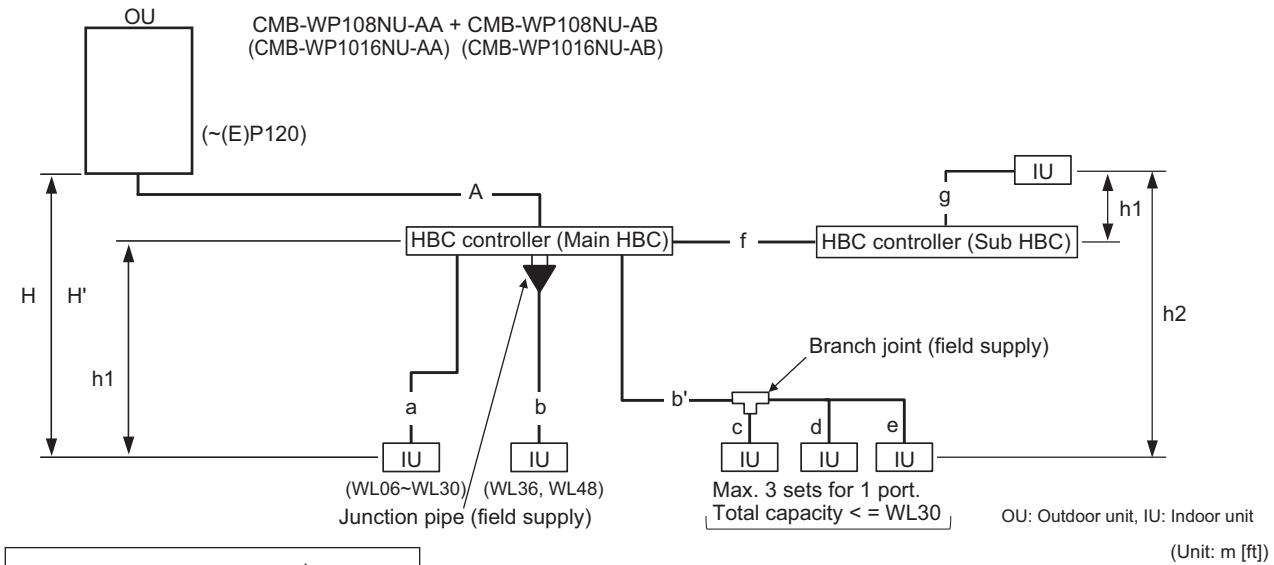
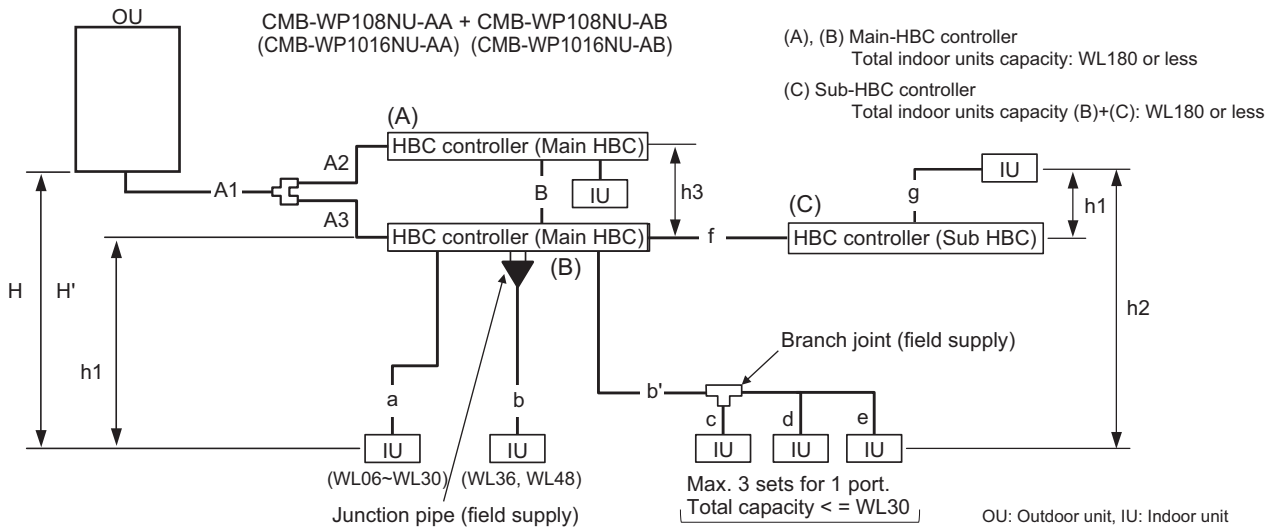

Fig. A

	Item	Piping portion	Allowable value
Pipe Lengths	Between outdoor unit and HBC controller (refrigerant pipework)	A	110 [360] or less
	Water pipework between indoor units and HBC controller	f + g	60 [196] or less
Difference of elevation	Between indoor and outdoor units	Above outdoor unit	H
		Below outdoor unit	H'
	Between indoor units and HBC controller	h1	15 (10) [49 (33)] or less *3
	Between indoor units	h2	15 (10) [49 (33)] or less *3

*1. 113 m is available depending on the model and installation conditions. For more detailed information, contact your local distributor.
 *2. 60 m is available depending on the model and installation conditions. For more detailed information, contact your local distributor.
 *3. Values in () are applied when indoor total capacity exceeds 130% of outdoor unit capacity



	Item	Piping portion	Allowable value
Pipe Lengths	Between outdoor unit and HBC controller (refrigerant pipework)	A1 + A2 + A3	110 [360] or less
	Water pipework between indoor units and HBC controller	f + g	60 [196] or less
	Between HBC controllers	B	40 [131] or less
Difference of elevation	Between indoor and outdoor units	Above outdoor unit	H
		Below outdoor unit	H'
	Between indoor units and HBC controller	h1	15 (10) [49 (33)] or less *3
	Between indoor units	h2	15 (10) [49 (33)] or less *3
	Between HBC controllers	h3	15 (10) [49 (33)] or less *3

*1. 113 m is available depending on the model and installation conditions. For more detailed information, contact your local distributor.
 *2. 60 m is available depending on the model and installation conditions. For more detailed information, contact your local distributor.
 *3. Values in () are applied when indoor total capacity exceeds 130% of outdoor unit capacity

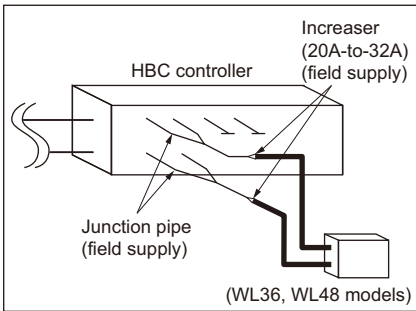
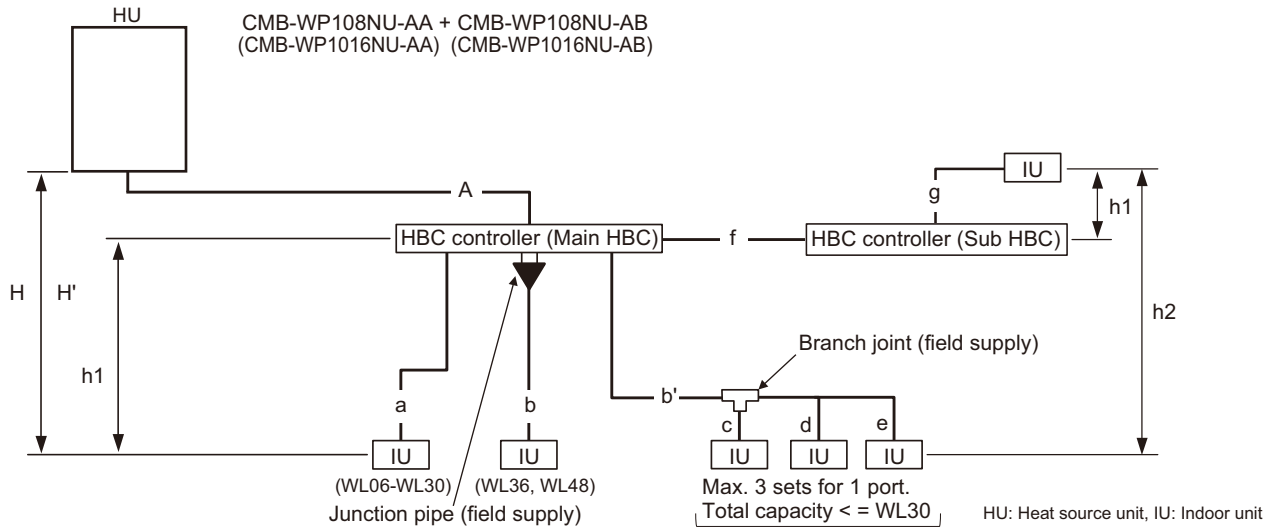
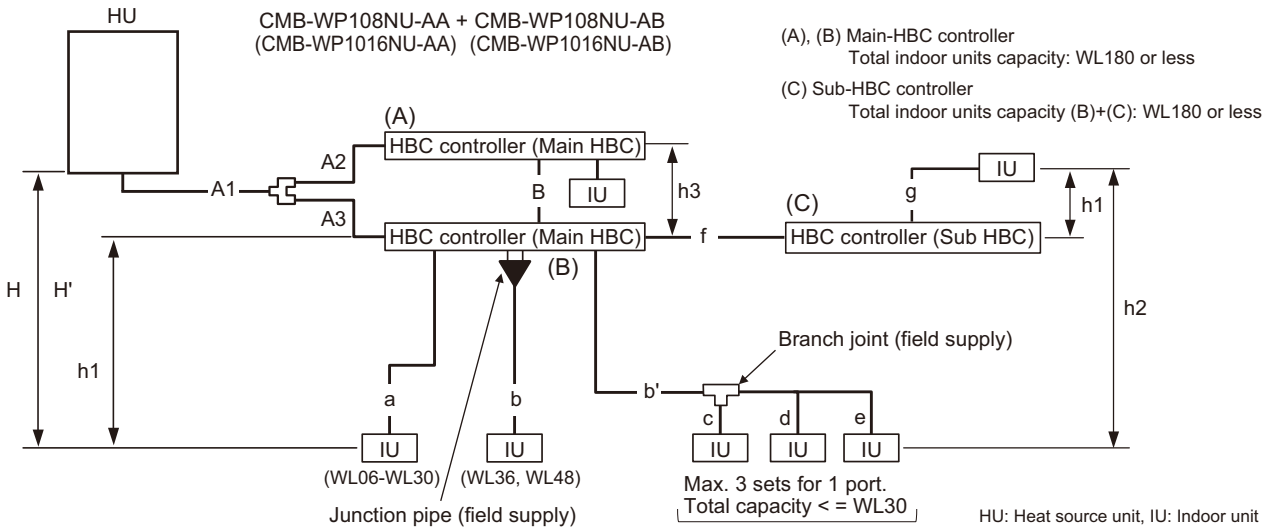

Fig. A

(Unit: m [ft])

	Item	Piping portion	Allowable value
Pipe Lengths	Between heat source unit and HBC controller (refrigerant pipework)	A	110 [360] or less
	Water pipework between indoor units and HBC controller	f + g	60 [196] or less
Difference of elevation	Between indoor and heat source units	Above heat source unit	H
		Below heat source unit	H'
	Between indoor units and HBC controller	h1	15 (10) [49 (33)] or less *1
	Between indoor units	h2	15 (10) [49 (33)] or less *1

*1. Values in () are applied when indoor total capacity exceeds 130% of heat source unit capacity



- (A), (B) Main-HBC controller
Total indoor units capacity: WL180 or less
- (C) Sub-HBC controller
Total indoor units capacity (B)+(C): WL180 or less

(Unit: m [ft])

	Item	Piping portion	Allowable value
Pipe Lengths	Between heat source unit and HBC controller (refrigerant pipework)	A1 + A2 + A3	110 [360] or less
	Water pipework between indoor units and HBC controller	f + g	60 [196] or less
	Between HBC controllers	B	40 [131] or less
Difference of elevation	Between indoor and heat source units	Above heat source unit	H
		Below heat source unit	H'
	Between indoor units and HBC controller	h1	15 (10) [49 (33)] or less *1
	Between indoor units	h2	15 (10) [49 (33)] or less *1
	Between HBC controllers	h3	15 (10) [49 (33)] or less *1

*1. Values in () are applied when indoor total capacity exceeds 130% of heat source unit capacity

1. Refrigerant and water pipe size

(1) Refrigerant pipe between outdoor unit and HBC controller (Part A, A1, A2, and A3)

1) Use of one HBC controller

(Unit: mm [in])

Unit model		HBC controller		
		Model name	High pressure side	Low pressure side
Outdoor unit side	PURY-(E)P72T/YNU	(HBC controller)	ø15.88 [5/8] (Brazeing)	ø19.05 [3/4] (Brazeing)
	PURY-(E)P96T/YNU	CMB-WP108NU-AA	ø19.05 [3/4] (Brazeing)	ø22.2 [7/8] (Brazeing)
	PURY-(E)P120T/YNU	CMB-WP1016NU-AA *1	ø19.05 [3/4] (Brazeing)	ø28.58 [1-1/8] (Brazeing)

2) Use of two HBC controllers

Unit model		Model name	HBC controller			
			Between outdoor unit and twinning pipe		Between twinning pipe and HBC controller	
			High pressure side	Low pressure side	High pressure side	Low pressure side
Outdoor unit side	PURY-(E)P72T/YNU	(HBC controller) CMB-WP108NU-AA CMB-WP1016NU-AA *1	ø15.88 [5/8] (Brazeing)	ø19.05 [3/4] (Brazeing)	ø15.88 [5/8] (Brazeing) for each HBC controller	ø19.05 [3/4] (Brazeing) for each HBC controller
	PURY-(E)P96T/YNU		ø19.05 [3/4] (Brazeing)	ø22.2 [7/8] (Brazeing)	ø15.88 [5/8] (Brazeing) for each HBC controller	ø19.05 [3/4] (Brazeing) for each HBC controller
	PURY-(E)P120T/YNU		ø19.05 [3/4] (Brazeing)	ø28.58 [1-1/8] (Brazeing)	ø15.88 [5/8] (Brazeing) for each HBC controller	ø19.05 [3/4] (Brazeing) for each HBC controller
	PURY-(E)P144T/YNU		ø22.2 [7/8] (Brazeing)	ø28.58 [1-1/8] (Brazeing)	ø15.88 [5/8] (Brazeing) for each HBC controller	ø19.05 [3/4] (Brazeing) for each HBC controller
	PURY-(E)P168T/YNU		ø22.2 [7/8] (Brazeing)	ø28.58 [1-1/8] (Brazeing)	ø19.05 [3/4] (Brazeing) for each HBC controller	ø22.2 [7/8] (Brazeing) for each HBC controller

*1 PURY-(E)P144T/YNU model or larger requires a connection of two main-HBC controllers in parallel.

3) Use of one HBC controller

(Unit: mm [in])

Unit model		HBC controller		
		Model name	High pressure side	Low pressure side
Outdoor unit side	PURY-P72ZKMU	(HBC controller)	ø15.88 [5/8] (Brazeing)	ø19.05 [3/4] (Brazeing)
	PURY-P96ZKMU	CMB-WP108NU-AA	ø19.05 [3/4] (Brazeing)	ø22.2 [7/8] (Brazeing)
	PURY-P120ZKMU	CMB-WP1016NU-AA *1	ø19.05 [3/4] (Brazeing)	ø28.58 [1-1/8] (Brazeing)

4) Use of two HBC controllers

Unit model		Model name	HBC controller			
			Between outdoor unit and twinning pipe		Between twinning pipe and HBC controller	
			High pressure side	Low pressure side	High pressure side	Low pressure side
Outdoor unit side	PURY-P72ZKMU	(HBC controller) CMB-WP108NU-AA CMB-WP1016NU-AA *1	ø15.88 [5/8] (Brazeing)	ø19.05 [3/4] (Brazeing)	ø15.88 [5/8] (Brazeing) for each HBC controller	ø19.05 [3/4] (Brazeing) for each HBC controller
	PURY-P96ZKMU		ø19.05 [3/4] (Brazeing)	ø22.2 [7/8] (Brazeing)	ø15.88 [5/8] (Brazeing) for each HBC controller	ø19.05 [3/4] (Brazeing) for each HBC controller
	PURY-P120ZKMU		ø19.05 [3/4] (Brazeing)	ø28.58 [1-1/8] (Brazeing)	ø15.88 [5/8] (Brazeing) for each HBC controller	ø19.05 [3/4] (Brazeing) for each HBC controller
	PURY-P144ZKMU		ø22.2 [7/8] (Brazeing)	ø28.58 [1-1/8] (Brazeing)	ø15.88 [5/8] (Brazeing) for each HBC controller	ø19.05 [3/4] (Brazeing) for each HBC controller

*1 PURY-P144ZKMU model or larger requires a connection of two main-HBC controllers in parallel.

5) Use of one HBC controller

(Unit: mm [in])

Unit model		HBC controller		
		Model name	High pressure side	Low pressure side
Heat source unit side	PQRY-P72T/Y/ZLMU	(HBC controller)	ø15.88 [5/8] (Brazeing)	ø19.05 [3/4] (Brazeing)
	PQRY-P96T/Y/ZLMU	CMB-WP108NU-AA	ø19.05 [3/4] (Brazeing)	ø22.2 [7/8] (Brazeing)
	PQRY-P120T/Y/ZLMU	CMB-WP1016NU-AA *1	ø19.05 [3/4] (Brazeing)	ø22.2 [7/8] (Brazeing)

6) Use of two HBC controllers

Unit model		Model name	HBC controller			
			Between outdoor unit and twinning pipe		Between twinning pipe and HBC controller	
			High pressure side	Low pressure side	High pressure side	Low pressure side
Heat source unit side	PQRY-P72T/Y/ZLMU	(HBC controller) CMB-WP108NU-AA CMB-WP1016NU-AA *1	ø15.88 [5/8] (Brazeing)	ø19.05 [3/4] (Brazeing)	ø15.88 [5/8] (Brazeing) for each HBC controller	ø19.05 [3/4] (Brazeing) for each HBC controller
	PQRY-P96T/Y/ZLMU		ø19.05 [3/4] (Brazeing)	ø22.2 [7/8] (Brazeing)	ø15.88 [5/8] (Brazeing) for each HBC controller	ø19.05 [3/4] (Brazeing) for each HBC controller
	PQRY-P120T/Y/ZLMU		ø19.05 [3/4] (Brazeing)	ø22.2 [7/8] (Brazeing)	ø15.88 [5/8] (Brazeing) for each HBC controller	ø19.05 [3/4] (Brazeing) for each HBC controller
	PQRY-P144T/Y/ZLMU		ø22.2 [7/8] (Brazeing)	ø28.58 [1-1/8] (Brazeing)	ø15.88 [5/8] (Brazeing) for each HBC controller	ø19.05 [3/4] (Brazeing) for each HBC controller
	PQRY-P168T/Y/ZLMU		ø22.2 [7/8] (Brazeing)	ø28.58 [1-1/8] (Brazeing)	ø19.05 [3/4] (Brazeing) for each HBC controller	ø22.2 [7/8] (Brazeing) for each HBC controller

*1 PQRY-P144T/Y/ZLMU model or larger requires a connection of two main-HBC controllers in parallel.

(2) Water pipe between HBC controller and indoor units (Sections a, b, c, d, e, and g)

Total down-stream indoor unit capacity	Pipe size between Main-HBC and indoor unit Pipe size between Sub-HBC and indoor unit
WL06-WL23	I.D. ≥ 20.0 mm [13/16 in]
WL24-WL48	I.D. ≥ 30.0 mm [1-3/16 in]

* The diameter of HBC ports is O.D. 22.0 mm.

(3) Water pipe between HBC controller and Sub-HBC

Total down-stream indoor unit capacity	Pipe size between Main-HBC and Sub-HBC
-WL36	I.D. ≥ 20.0 mm [13/16 in]
WL37-WL72	I.D. ≥ 25.8 mm [1-1/16 in]
WL73-WL108	I.D. ≥ 30.0 mm [1-3/16 in]
WL109-WL144	I.D. ≥ 33.3 mm [1-5/16 in]
WL145-WL180	I.D. ≥ 36.2 mm [1-7/16 in]

* The diameter of HBC ports is O.D. 22.0 mm.

(4) Refrigerant pipe between HBC controller and HBC controller (Section B)

Unit: mm [in]

ø15.88 [5/8] (Brazen connection)

2. Connecting the HBC controller

(1) Size of the pipe that fits the standard HBC ports

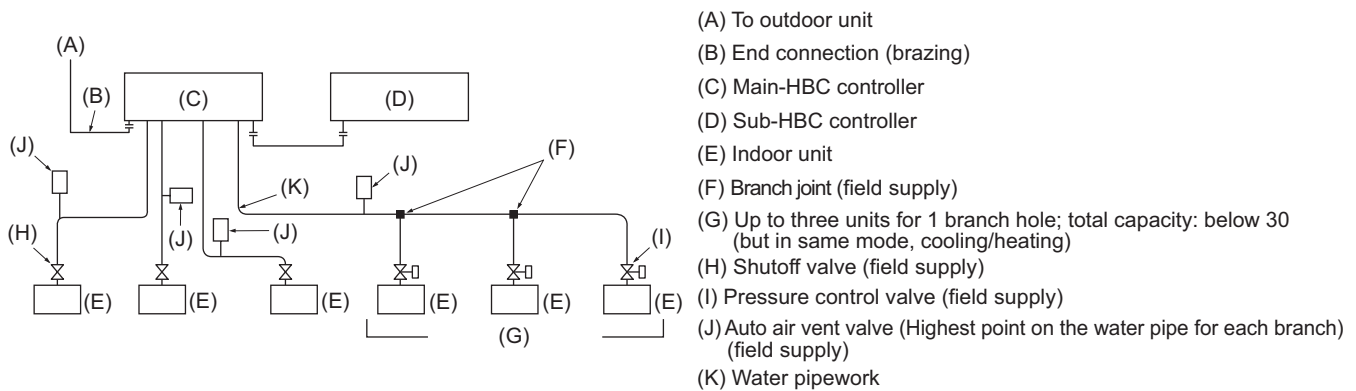

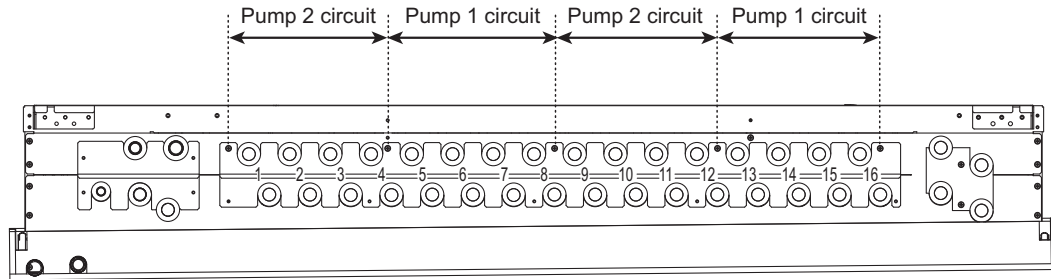

Fig. B

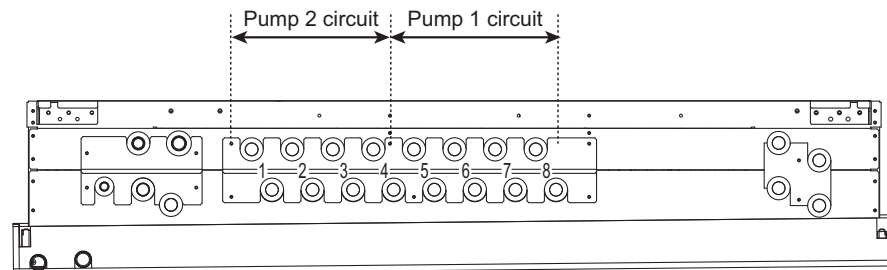

Fig. C

Note: 1

To connect multiple indoor units to a port

- ◆Maximum total capacity of connected indoor units: WL30
- ◆Maximum number of connectable indoor units: 3 units
- ◆Branch joints are field-supplied.
- ◆All the indoor units that are connected to the same port must be in the same group and perform the Thermo-ON/OFF operation simultaneously.
- ◆The room temperatures of all the indoor units in the group need to be monitored via the connected remote controller.
- ◆When connecting a WL27 through 48 model indoor unit to an HBC controller, the pipes that connect the unit to the same set of HBC controller ports cannot be branched out to connect additional units.
- ◆Selection of water piping
- ◆Select the size according to the total capacity of indoor units to be installed downstream.
- ◆Do not connect multiple indoor units to the same port when operating each of them in different modes (cooling, heating, stop, and thermo-OFF). The indoor units connected to the same port must be set to operate in the same mode. Set them to the same group to make them run/stop in the same mode all together. Alternatively, enable the thermo setting on the remote controller, or set the common thermostat (optional) to run/stop the units in the same mode based on the representative temperature.
- ◆When multiple indoor units are connected to a single port, install a pressure control valve in the pipe to equalize the pressure of all indoor units.

Note: 2

Connecting WL36 or 48 indoor units to an HBC controller

- ◆When connecting WL36 or 48 indoor units to an HBC controller, connect each unit to two sets of two ports on the HBC controller, using two junction pipes (Y-joints). (See Fig. A.)
- ◆Connect an increaser (20A to 32A) to the merged side of each junction pipe. (See Fig. A.)
- ◆When the junction pipes are connected to 16 HBC ports, the branched sides of the junction pipes cannot be connected to the ports "4 and 5," "8 and 9," or "12 and 13" at the same time. (See Fig. B.)
- ◆When the junction pipes are connected to 8 HBC ports, the branched sides of the junction pipes cannot be connected to the ports "4 and 5" at the same time. (See Fig. C.)
- ◆When a WL36 or a 48 model indoor unit is connected to an HBC controller, the pipes that connect the unit to the same set of HBC ports cannot be branched out to connect additional units.

Note: 3

Maximum capacity of indoor units connectable to an HBC controller for obtaining the rated performance

- ◆An HBC controller has two pumps. Each pump can accommodate the capacity equivalent to WL67 indoor units.
- ◆When connecting the pipe to 16 HBC ports, make sure that the total capacity of the indoor units connected to ports "1 through 4 and 9 through 12" or "5 through 8 and 13 through 16" will not exceed WL67 and will be equal as much as possible. (See Fig. B.)

When connecting the pipe to 8 HBC ports, make sure that the total capacity of the indoor units connected to ports "1 through 4" or "5 through 8" will not exceed WL67 and will be equal as much as possible. (See Fig. C.)

If the total capacity exceeds WL67, the performance will be degraded.

7-6-2. Drain piping work

1. Drain piping work

- Ensure that the drain piping is sloped downward (sloped gradient of more than 1/100) toward the discharge side. If it is impossible to take any downward pitch, use an optionally available drain pump to obtain a downward pitch of more than 1/100.
- Ensure that any cross-wise drain piping is less than 20 m [65 ft]. If the drain piping is long, support it with metal brackets to prevent it from bending, warping, or vibrating.
- Use a hard vinyl chloride pipe for drain piping.
- Ensure that collected pipes are 10 cm [3-15/16 in] lower than the unit body's drain port.
- Do not provide any odor trap at the drain discharge port.
- Put the end of the drain piping in a position where no odor is generated.
- Do not put the end of the drain piping in any drain where ionic gases are generated.
- When connecting the drain pipe to only one drain socket, use the drain socket at the bottom, and cover the top one.

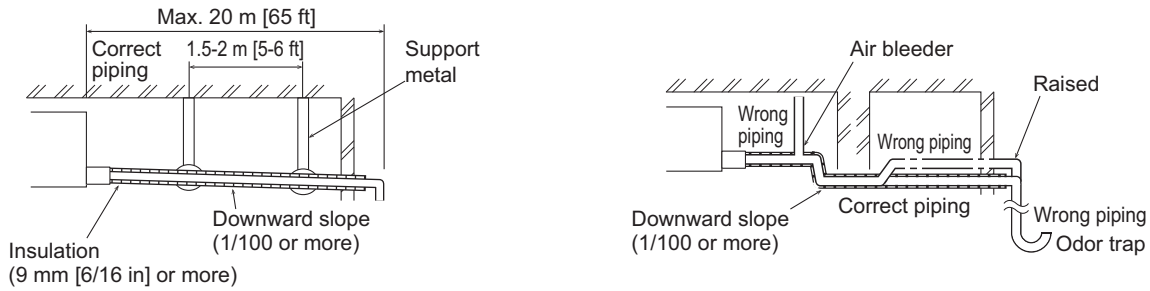

[Grouped piping]

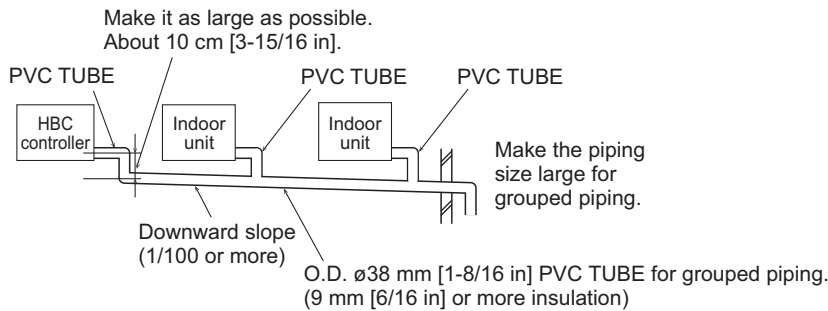

- Insert the adapter (not supplied) into the drain port.
 - Apply wraps overlapping of sealing tape (2 times)
 - Torque the drain pan adapter to 2.5 Nm+/-0.5 [22 in-lbs]
- Attach the drain pipe (PVC TUBE, not supplied). (Attach the pipe with glue.)
- Perform insulation work on the drain pipe (PVC TUBE) and on the socket (including elbow).
- Check the drainage.
- Attach the insulating material, and fix it with the band (not supplied) to insulate the drain port.

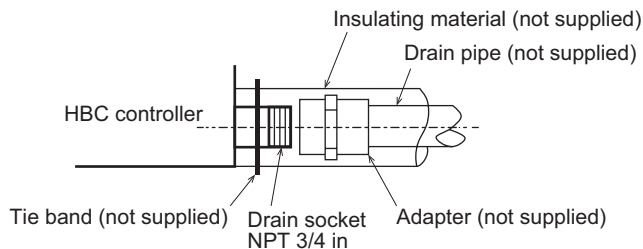

2. Discharge test

After completing drain piping work, open the HBC controller panel, and test drain discharge using a small amount of water. Also, check to see that there is no water leakage from the connections.

3. Insulating drain pipes

Provide sufficient insulation to the drain pipes just as for refrigerant pipes.

⚠ CAUTION

Be sure to provide drain piping with heat insulation in order to prevent excess condensation. Without drain piping, water may leak from the unit causing damage to your property.

7-6-3. Connecting water pipe work

Please observe the following precautions during installation.

7-6-3-1 Important notes on water pipework installation

- The design pressure of the HBC controller water system is 0.6 MPa [87 psi].
- Use water pipe-work with a design pressure of at least 1.0 MPa [145 psi].
- When performing a water leak check, please do not allow the water pressure to go above 0.3 MPa [44 psi].
- Perform a pressure test on the field-installed water pipes at a pressure equal to 1.5 times the design pressure. Before performing a pressure test, isolate the pipes from HBC controller and indoor units.
- Please connect the water pipework of each indoor unit to the connect port on the HBC controller. Failure to do so will result in incorrect running.
- Please list the indoor units on the naming plate in the HBC controller with addresses and end connection numbers.
- Use the reverse-return method to insure proper pipe resistance to each unit.
- Provide some joints and valves around inlet/outlet of each unit for easy maintenance, checkup, and replacement.
- Install a suitable air vent on the water pipe. After flowing water through the pipe, vent any excess air.
- Secure the pipes with metal fitting, positioning them in locations to protect pipes against breakage and bending.
- Do not confuse the water intake and outlet piping especially when connecting the HBC controller and the Sub-HBC controller. (Error code 5102 will appear on the remote controller if a test run is performed with the pipe-work installed incorrectly (inlet connected to outlet and vice versa).)
- This unit doesn't include a heater to prevent freezing within tubes. If the water flow is stopped on low ambient, drain the water out.
- The unused knockout holes should be closed and the refrigerant pipes, water pipes, power source and transmission wires access holes should be filled with putty.
- Install water pipe so that the water flow rate will be maintained.
- Wrap sealing tape as follows.
 1. Wrap the joint with sealing tape following the direction of the threads (clockwise), do not wrap the tape over the edge.
 2. Overlap the sealing tape by two-thirds to three-fourths of its width on each turn. Press the tape with your fingers so that it is tight against each thread.
 3. Do not wrap the 1.5th through 2nd farthest threads away from the pipe end.
- Hold the pipe on the unit side in place with a spanner when installing the pipes or strainer. Tighten screws to a torque of 40 N·m.
- If there is a risk of freezing, carry out a procedure to prevent it.
- When connecting the HBC controller water piping and on site water piping, apply liquid sealing material for water piping over the sealing tape before connection.
- Please use copper or plastic pipes for the water circuit. Do not use steel or stainless steel pipework. Furthermore, when using copper pipe-work, use a non-oxidative brazing method. Oxidation of the pipe-work will reduce the pump life.
- Add water pressure gauge to see if the water pressure in HBC controller is correct or not.
- **Be sure to braze the water pipes after covering a wet cloth to the insulation pipes of the units in order to prevent them from burning and shrinking by heat.** (There are some plastic parts in HBC controller.)
- **Install the unit so that external force is not applied to the water pipes.**
- **After filling the pipes with water, immediately perform debris removal operation and air vent operation.**
- If you use a hose for water supply, use a new hose-set.

Example of heat source unit installation (using left piping)

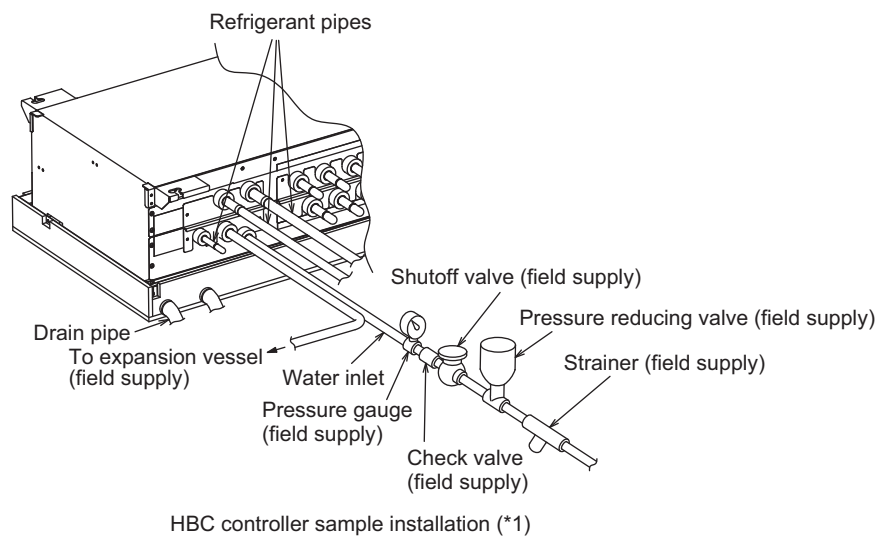

*1. Connect the pipes to the water pipes according to the local regulations.

- The HBC system must be serviced at least once a year.

7-6-3-2 Water pipe insulation

1. Connect the water pipes of each indoor unit to the same (correct) end connection numbers as indicated on the indoor unit connection section of each HBC controller. If connected to wrong end connection numbers, there will be no normal operation.
2. List indoor unit model names in the name plate on the HBC controller control box (for identification purposes), and HBC controller end connection numbers and address numbers in the name plate on the indoor unit side.
Seal unused end connections using cover caps (field supply, dezincification resistant brass (DZR) or bronze only). Not replacing the rubber end caps will lead to water leakage.
3. Be sure to add insulation work to water piping by covering water pipework separately with enough thickness heat-resistant polyethylene, so that no gap is observed in the joint between indoor unit and insulating material, and insulating materials themselves. When insulation work is insufficient, there is a possibility of condensation, etc. Pay special attention to insulation work in the ceiling plenum.

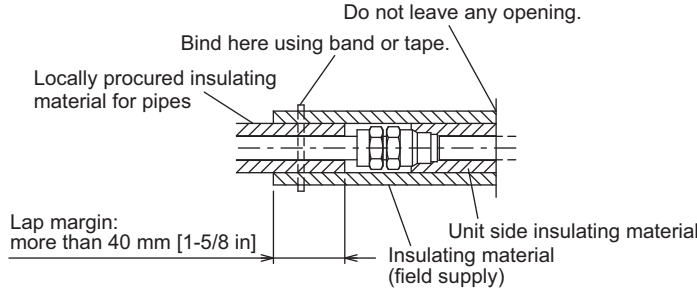

- Insulation materials for the pipes to be added on site must meet the following specifications:

HBC controller - indoor unit	20 mm [13/16 in] or more
HBC controller - Sub-HBC controller	20 mm [13/16 in] or more

- This specification is based on copper for water piping. When using plastic pipework, choose a thickness based on the plastic pipe performance.
- Installation of pipes in a high-temperature high-humidity environment, such as the top floor of a building, may require the use of insulation materials thicker than the ones specified in the chart above.
- When certain specifications presented by the client must be met, ensure that they also meet the specifications on the chart above.

4. Expansion vessel

- Install an expansion tank to accommodate expanded water.

Expansion vessel selection criteria:

Water containment volume of the HBC controller

- Refer to the relevant indoor unit specifications for information on the water volume.

(Unit: L)

Unit model	Water volume
CMB-WP108NU-AA	10
CMB-WP1016NU-AA	13
CMB-WP108NU-AB	5
CMB-WP1016NU-AB	9
PEFY-WL06NMAU	0.9
PEFY-WL08NMAU	
PEFY-WL12NMAU	
PEFY-WL15NMAU	1.2
PEFY-WL18NMAU	2.1
PEFY-WL24NMAU	
PEFY-WL27NMAU	
PEFY-WL30NMAU	2.7
PEFY-WL36NMAU	
PEFY-WL48NMAU	3.7

- The maximum water temperature is 60°C [140°F].
- The minimum water temperature is 5°C [41°F].
- The circuit protection valve set pressure is 370-490 kPa.
- The circulation pump head pressure is 0.24 MPa.
- The design pressure of the expansion vessel is the charged water pressure (the reading of the pressure gauge).
- Tank volume of expansion vessel is as follows:
 $Tank\ volume = \epsilon \times G / (1 - (P_{supply} + 0.1) / 0.29) \times 1.2$
 $\epsilon =$ The expansion coefficient of water
 (= 0.0171)
 * Please choose ϵ for using antifreeze solution on the type and temperature range used.
 $\epsilon = Max\ density / Min\ density - 1$
 $G [L] = (HBC\ controller [L] + Indoor\ unit [L] + Pipe [L]) \times 1.1$
 P_{supply} : Water supply pressure [MPa]

* For other indoor units, refer to the installation manual for each.

5. Leakproof the water pipework, valves and drain pipework. Leakproof all the way to, and include pipe ends so that condensation cannot enter the insulated pipework.
6. Apply caulking around the ends of the insulation to prevent condensation getting between the pipework and insulation.
7. Add a drain valve so that the unit and pipework can be drained.
8. Ensure there are no gaps in the pipework insulation. Insulate the pipework right up to the unit.
9. Ensure that the gradient of the drain pan pipework is such that discharge can only flow out.
10. HBC water pipe connection sizes and pipe sizes.

Model name	Connection size		Pipe size	
	Water inlet	Water outlet	Water out	Water return
WL06-WL23	O.D. 22 mm	O.D. 22 mm	I.D. ≥ 20 mm [13/16 in]	I.D. ≥ 20 mm [13/16 in]
WL24-WL48			I.D. ≥ 30 mm [1-3/16 in]	I.D. ≥ 30 mm [1-3/16 in]

* For other indoor units, refer to the indoor unit's DATA BOOK.

* The pipe diameter depends on the capacity of indoor units.

Refer to the indoor unit's DATA BOOK for details.

11. Please refer to the figure below when connecting the water supply.

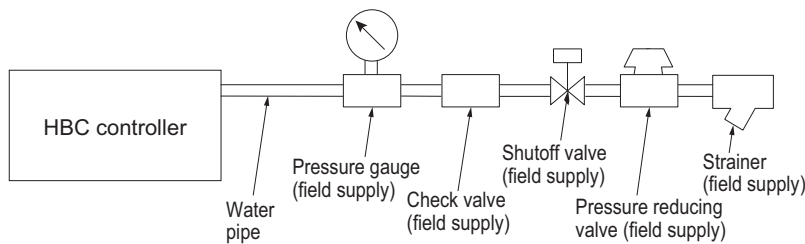

12. Use formula $0.1 \leq 0.01 + 0.01 \times A \leq 0.16$ for the supply pressure range to be used.

(A: Head pressure (m) between the HBC and the highest indoor unit)

If the supply pressure is greater than 0.16 MPa, use a pressure reducing valve to keep the pressure within the range.

If the head pressure is unknown, set it to 0.16 MPa.

13. Install a shut off valve and strainer in a place that is easy to operate and makes maintenance work easy.

14. Apply insulation to the indoor unit pipework, strainer, shut off valve, and pressure reducing valve.

15. Please do not use a corrosion inhibitor in the water system.

16. When installing the HBC unit in an environment which may drop below 0°C [32°F], please add antifreeze (Propylene Glycol only) to the circulating water. For the brine selection, refer to 7-3. "Correction by antifreeze solution concentration".

7-6-3-3. Water treatment and quality control

To preserve water quality, use the closed type of water circuit. When the circulating water quality is poor, the water heat exchanger can develop scale, leading to a reduction in heat-exchange power and possible corrosion.

Pay careful attention to water processing and water quality control when installing the water circulation system.

•Removing of foreign objects or impurities within the pipes.

During installation, make sure that foreign objects, such as welding fragments, sealant particles, or rust, do not enter the pipes.

•Water Quality Processing

1. Depending on the quality of the cold-temperature water used in the airconditioner, the copper piping of the heat exchanger may corrode. Regular water quality processing is recommended. If a water supply tank is installed, keep air contact to a minimum, and keep the level of dissolved oxygen in the water no higher than 1mg/l.

2. Water quality standard

Items	Lower mid-range temperature water system		Tendency		
	Recirculating water [20<T<60°C] [68<T<140°F]	Make-up water	Corrosive	Scale-forming	
Standard items	pH (25°C[77°F])	7.0 ~ 8.0	7.0 ~ 8.0	○	○
	Electric conductivity (mS/m) (25°C[77°F]) (μS/cm) (25°C[77°F])	30 or less [300 or less]	30 or less [300 or less]	○	○
	Chloride ion (mg Cl ⁻ /ℓ)	50 or less	50 or less	○	
	Sulfate ion (mg SO ₄ ²⁻ /ℓ)	50 or less	50 or less	○	
	Acid consumption (pH4.8) (mg CaCO ₃ /ℓ)	50 or less	50 or less		○
	Total hardness (mg CaCO ₃ /ℓ)	70 or less	70 or less		○
	Calcium hardness (mg CaCO ₃ /ℓ)	50 or less	50 or less		○
Reference items	Ionic silica (mg SiO ₂ /ℓ)	30 or less	30 or less		○
	Iron (mg Fe/ℓ)	1.0 or less	0.3 or less	○	○
	Copper (mg Cu/ℓ)	1.0 or less	0.1 or less	○	
	Sulfide ion (mg S ²⁻ /ℓ)	not to be detected	not to be detected	○	
	Ammonium ion (mg NH ₄ ⁺ /ℓ)	0.3 or less	0.1 or less	○	
	Residual chlorine (mg Cl/ℓ)	0.25 or less	0.3 or less	○	
	Free carbon dioxide (mg CO ₂ /ℓ)	0.4 or less	4.0 or less	○	
Ryzner stability index	6.0 ~ 7.0	-	○	○	

Reference : Guideline of Water Quality for Refrigeration and Air Conditioning Equipment. (JRA GL02E-1994)

3. Consult with a specialist about water quality control methods and calculations before using anti-corrosive solutions.

7-6-3-4. Notes on corrosion

1. Debris in the water

Sand, pebbles, suspended solids, and corrosion products in water can damage the metal pipe and heat exchanger on the HBC controller and may cause corrosion. When installing, prevent debris from entering the water. If there is debris in the water, perform debris removal operation after test run by cleaning the strainers inside the HBC controller.

2. Connecting pipes made of different materials

Connecting pipes used for HBC controller and indoor unit are copper alloy pipes. If steel pipes are connected to the pipes, the contact surface will corrode. Do not use steel pipes to avoid corrosion.

3. Residual air

Residual air in the pipe results in water pump malfunction, noise, or water pipe corrosion in the water circuit. Ensure air is purged before use.

7-6-4. Refrigerant charging calculation

7-6-4-1. Outdoor unit model: T/YNU-A/A1

<Amount of refrigerant to be added>

The amount of refrigerant that is shown in the table below is factory-charged to the outdoor units.
The amount necessary for extended pipe (field piping) is not included and must be added on site.

Outdoor unit model	Amount of pre-charged refrigerant in the outdoor unit [kg (oz)]
(E)P72T/YNU-A/A1	5.2 (184)
(E)P96T/YNU-A/A1	8.0 (283)
(E)P120T/YNU-A/A1	8.0 (283)
(E)P144T/YNU-A/A1	10.8 (381)
(E)P168T/YNU-A/A1	10.8 (381)

■ Calculation formula

The amount of refrigerant to be added depends on the size and the length of field piping. (unit in m [ft])

1) When the distance between HBC controller and outdoor unit is longer than 30.5 m (100 ft):

Amount of added refrigerant (kg) = $(0.21 \times L_1) + (0.14 \times L_2) + (0.1 \times L_3) + \alpha_1$
 Amount of added refrigerant (oz) = $(2.26 \times L_1) + (1.51 \times L_2) + (1.08 \times L_3) + \alpha_1$

2) When the distance between HBC controller and outdoor unit is 30.5 m (100 ft) or shorter:

Amount of added refrigerant (kg) = $(0.23 \times L_1) + (0.16 \times L_2) + (0.11 \times L_3) + \alpha_1 + \text{Table <A>}$
 Amount of added refrigerant (oz) = $(2.48 \times L_1) + (1.73 \times L_2) + (1.19 \times L_3) + \alpha_1 + \text{Table <A>}$

- L₁ : Length of ø22.2 [7/8"] high pressure pipe [m (ft)]
- L₂ : Length of ø19.05 [3/4"] high pressure pipe [m (ft)]
- L₃ : Length of ø15.88 [5/8"] high pressure pipe [m (ft)]
- α₁: Refer to the table below.

Use of one HBC controller

Outdoor unit index	Diameter of high-pressure pipe	Amount for the HBC controller α ₁ [kg (oz)]
(E)P72	ø15.88 [5/8]	
(E)P96	ø19.05 [3/4]	3.0 (106)
(E)P120	ø19.05 [3/4]	

Use of two HBC controllers

Outdoor unit index	Diameter of high-pressure pipe	Amount for the HBC controller α ₁ [kg (oz)]
(E)P72	ø15.88 [5/8]	
(E)P96	ø19.05 [3/4]	3.0 (106) × 2
(E)P120	ø19.05 [3/4]	
(E)P144	ø22.2 [7/8]	
(E)P168	ø22.2 [7/8]	

Outdoor unit model	Amount [kg (oz)]
(E)P72	1.5 (53)
(E)P96	1.5 (53)
(E)P120	3.0 (106)
(E)P144	2.5 (89)
(E)P168	4.0 (142)

Table <A>

Round up the calculation result to the nearest 0.1 kg (oz). (Example: 18.04 kg to 18.1 kg)

* In the case all connected indoor unit models are Case 1, do Not add the refrigerant listed in Table <A>. Instead, add the following amount of refrigerant.
 Case 1: PEFY-WL06/24NMAU-A** → Add 0.55 kg per PEFY-WL06/24NMAU-A**.

7-6-4-2. Outdoor unit model: ZKMU-A/B

<Amount of refrigerant to be added>

The amount of refrigerant that is shown in the table below is factory-charged to the outdoor units.
The amount necessary for extended pipe (field piping) is not included and must be added on site.

Outdoor unit model	Amount of pre-charged refrigerant in the outdoor unit [kg (oz)]
P72ZKMU-A/B	9.5 (336)
P96ZKMU-A/B	10.3 (363)
P120ZKMU-A/B	11.8 (417)
P144ZKMU-A/B	11.8 (417)

■ Calculation formula

The amount of refrigerant to be added depends on the size and the length of field piping. (unit in m [ft])

1) When the distance between HBC controller and outdoor unit is longer than 30.5 m (100 ft):

$$\text{Amount of added refrigerant (kg)} = (0.21 \times L_1) + (0.14 \times L_2) + (0.1 \times L_3) + \alpha_1 + \text{Table }$$

$$\text{Amount of added refrigerant (oz)} = (2.26 \times L_1) + (1.51 \times L_2) + (1.08 \times L_3) + \alpha_1 + \text{Table }$$

2) When the distance between HBC controller and outdoor unit is 30.5 m (100 ft) or shorter:

$$\text{Amount of added refrigerant (kg)} = (0.23 \times L_1) + (0.16 \times L_2) + (0.11 \times L_3) + \alpha_1 + \text{Table }$$

$$\text{Amount of added refrigerant (oz)} = (2.48 \times L_1) + (1.73 \times L_2) + (1.19 \times L_3) + \alpha_1 + \text{Table }$$

L_1 : Length of $\phi 22.2$ [7/8"] high pressure pipe [m (ft)]

L_2 : Length of $\phi 19.05$ [3/4"] high pressure pipe [m (ft)]

L_3 : Length of $\phi 15.88$ [5/8"] high pressure pipe [m (ft)]

α_1 : Refer to the table below.

Use of one HBC controller

Outdoor unit index	Diameter of high-pressure pipe	Amount for the HBC controller α_1 [kg (oz)]
P72	$\phi 15.88$ [5/8]	
P96	$\phi 19.05$ [3/4]	3.0 (106)
P120	$\phi 19.05$ [3/4]	

Use of two HBC controllers

Outdoor unit index	Diameter of high-pressure pipe	Amount for the HBC controller α_1 [kg (oz)]
P72	$\phi 15.88$ [5/8]	
P96	$\phi 19.05$ [3/4]	3.0 (106)
P120	$\phi 19.05$ [3/4]	
P144	$\phi 22.2$ [7/8]	3.0 (106)

Outdoor unit model	Amount [kg (oz)]
P72 to 96	0.0 (0)
P120 to 144	5.5 (195)

Table

Round up the calculation result to the nearest 0.1 kg (oz). (Example: 18.04 kg to 18.1 kg)

* When connecting PEFY-WL06/24NMAU-A**, add 0.55 kg [20 oz] of refrigerant per indoor unit.

7-6-4-3. Heat source unit model: T/Y/ZLMU-A1

<Amount of refrigerant to be added>

The amount of refrigerant that is shown in the table below is factory-charged to the heat source units.
The amount necessary for extended pipe (field piping) is not included and must be added on site.

Heat source unit model	Amount of pre-charged refrigerant in the heat source unit [kg (oz)]
P72T/Y/ZLMU-A1	5.0 (177)
P96T/Y/ZLMU-A1	5.0 (177)
P120T/Y/ZLMU-A1	5.0 (177)
P144T/Y/ZLMU-A1	6.0 (212)
P168T/Y/ZLMU-A1	6.0 (212)

■ Calculation formula

The amount of refrigerant to be added depends on the size and the length of field piping. (unit in m [ft])

1) When the distance between HBC controller and heat source unit is longer than 30.5 m (100 ft):

$$\text{Amount of added refrigerant (kg)} = (0.21 \times L_1) + (0.14 \times L_2) + (0.1 \times L_3) + \alpha_1$$

$$\text{Amount of added refrigerant (oz)} = (2.26 \times L_1) + (1.51 \times L_2) + (1.08 \times L_3) + \alpha_1$$

2) When the distance between HBC controller and heat source unit is 30.5 m (100 ft) or shorter:

$$\text{Amount of added refrigerant (kg)} = (0.23 \times L_1) + (0.16 \times L_2) + (0.11 \times L_3) + \alpha_1$$

$$\text{Amount of added refrigerant (oz)} = (2.48 \times L_1) + (1.73 \times L_2) + (1.19 \times L_3) + \alpha_1$$

L_1 : Length of $\phi 22.2$ [7/8"] high pressure pipe [m (ft)]

L_2 : Length of $\phi 19.05$ [3/4"] high pressure pipe [m (ft)]

L_3 : Length of $\phi 15.88$ [5/8"] high pressure pipe [m (ft)]

α_1 : Refer to the table below.

Use of one HBC controller

Heat source unit index	Diameter of high-pressure pipe	Amount for the HBC controller α_1 [kg (oz)]
P72	$\phi 15.88$ [5/8]	
P96	$\phi 19.05$ [3/4]	3.0 (106)
P120	$\phi 19.05$ [3/4]	

Use of two HBC controllers

Heat source unit index	Diameter of high-pressure pipe	Amount for the HBC controller α_1 [kg (oz)]
P72	$\phi 15.88$ [5/8]	
P96	$\phi 19.05$ [3/4]	3.0 (106)
P120	$\phi 19.05$ [3/4]	
P144	$\phi 22.2$ [7/8]	3.0 (106)
P168	$\phi 22.2$ [7/8]	

Round up the calculation result to the nearest 0.1 kg (oz). (Example: 18.04 kg to 18.1 kg)

* When connecting PEFY-WL06/24NMAU-A**, add 0.55 kg [20 oz] of refrigerant per indoor unit.

Example

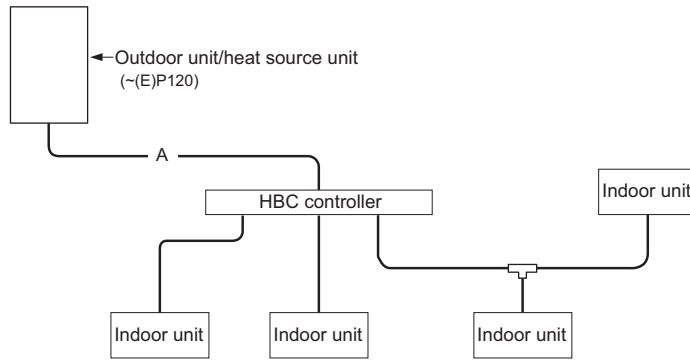

Sample calculation

Units "m" and "kg"

Indoor	1: 18	A: $\phi 19.05$	42 m
	2: 18		
	3: 18		
	4: 18		
Outdoor	P72TNU-A		

The total length of each liquid line is as follows:
 $\phi 19.05$: A = 42 m, $\alpha 1 = 3.0$, Table <A> = 1.5
 Therefore,
 <Calculation example>
 Additional refrigerant charge
 = $42 \times 0.14 + 3.0 + 1.5$
 = 10.38 kg
 ≈ 10.4 kg
 * All pipe work except A is water pipe work.

Units "ft" and "oz"

Indoor	1: 18	A: $\phi 3/4$	138 ft
	2: 18		
	3: 18		
	4: 18		
Outdoor	P72TNU-A		

The total length of each liquid line is as follows:
 $\phi 3/4$: A = 138 ft, $\alpha 1 = 106$, Table <A> = 53
 Therefore,
 <Calculation example>
 Additional refrigerant charge
 = $138 \times 1.51 + 106 + 53$
 = 367.38 oz
 ≈ 368 oz
 * All pipe work except A is water pipe work.

Example

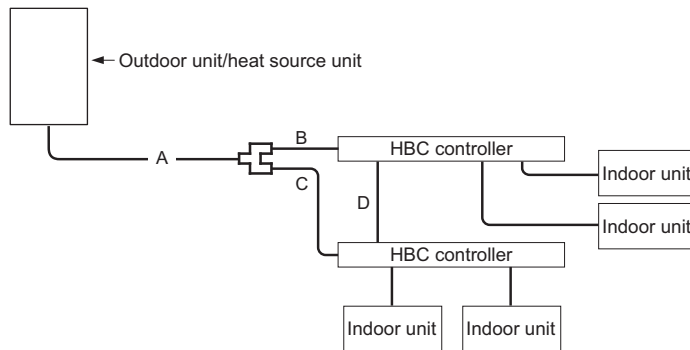

Sample calculation

Units "m" and "kg"

Indoor	1: 18	A: $\phi 22.2$	18 m
	2: 24	B: $\phi 15.88$	5 m
	3: 24	C: $\phi 15.88$	10 m
	4: 24	D: $\phi 15.88$	8 m
Outdoor	P144TNU-A		

The total length of each liquid line is as follows:
 $\phi 22.2$: A = 18 m, $\phi 15.88$: B + C + D = 23 m, $\alpha 1 = 3.0 \times 2$, Table <A> = 2.5
 Therefore,
 <Calculation example>
 Additional refrigerant charge
 = $18 \times 0.23 + (5 + 10 + 8) \times 0.11 + 3.0 \times 2 + 2.5$
 = 15.17 kg
 ≈ 15.2 kg
 * All pipe work except A, B, C, D is water pipe work.

Units "ft" and "oz"

Indoor	1: 18	A: $\phi 7/8$	59 ft
	2: 24	B: $\phi 5/8$	16 ft
	3: 24	C: $\phi 5/8$	32 ft
	4: 24	D: $\phi 5/8$	26 ft
Outdoor	P144TNU-A		

The total length of each liquid line is as follows:
 $\phi 7/8$: A = 59 ft, $\phi 5/8$: B + C + D = 74 ft, $\alpha 1 = 106 \times 2$, Table <A> = 89
 Therefore,
 <Calculation example>
 Additional refrigerant charge
 = $59 \times 2.48 + (16 + 32 + 26) \times 1.19 + 106 \times 2 + 89$
 = 535.38 oz
 ≈ 536 oz
 * All pipe work except A, B, C, D is water pipe work.

⚠ Warning

- Do not use refrigerant other than the type indicated in the manuals provided with the unit and on the nameplate.
 - Doing so may cause the unit or pipes to burst, or result in explosion or fire during use, repair, or at the time of disposal of the unit.
 - It may also be in violation of applicable laws.
 - MITSUBISHI ELECTRIC CORPORATION cannot be held responsible for malfunctions or accidents resulting from the use of the wrong type of refrigerant.
- Our air conditioning equipment and heat pumps contain a fluorinated greenhouse gas, R410A/R32.

MITSUBISHI ELECTRIC CORPORATION

www.MitsubishiElectric.com