

CITY MULTI

SYSTEM DESIGN Y SERIES

1. Electrical work.....	4 - 28
1-1.General cautions	4 - 28
1-2.Power supply for Indoor unit and Outdoor unit	4 - 29
1-3.Power cable specifications	4 - 33
1-4.Power supply examples.....	4 - 34
2. M-NET control.....	4 - 37
2-1.Transmission cable length limitation.....	4 - 37
2-2.Transmission cable specifications	4 - 38
2-3.System configuration restrictions.....	4 - 39
2-4.Address setting	4 - 42
3. Piping Design.....	4 - 51
3-1.R410A Piping material	4 - 51
3-2.Piping Design	4 - 52
3-3.Refrigerant charging calculation	4 - 55
4. Outdoor Installation.....	4 - 56
4-1.Requirement on installation site	4 - 56
4-2.Spacing.....	4 - 57
4-3.Piping direction	4 - 59
4-4.Weather countermeasure	4 - 64
4-5.Caution on selecting outdoor units	4 - 65
5. Caution for refrigerant leakage	4 - 66
5-1.Refrigerant property.....	4 - 66
5-2.Confirm the Critical concentration and take countermeasure.....	4 - 66

1-1. General cautions

- ① Follow ordinance of your governmental organization for technical standard related to electrical equipment, wiring regulations, and guidance of each electric power company.
- ② Wiring for control (hereinafter referred to as transmission cable) shall be (50mm[1-5/8in] or more) apart from power source wiring so that it is not influenced by electric noise from power source wiring. (Do not insert transmission cable and power source wire in the same conduit.)
- ③ Be sure to provide designated grounding work to outdoor unit.
- ④ Give some allowance to wiring for electrical part box of indoor and outdoor units, because the box is sometimes removed at the time of service work.
- ⑤ Never connect 100V, 208~230,460V power source to terminal block of transmission cable. If connected, electrical parts will be burnt out.
- ⑥ Use 2-core shield cable for transmission cable. If transmission cables of different systems are wired with the same multiple-core cable, the resultant poor transmitting and receiving will cause erroneous operations.

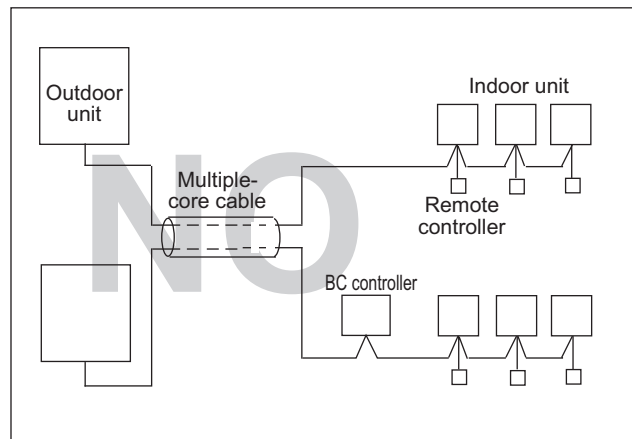
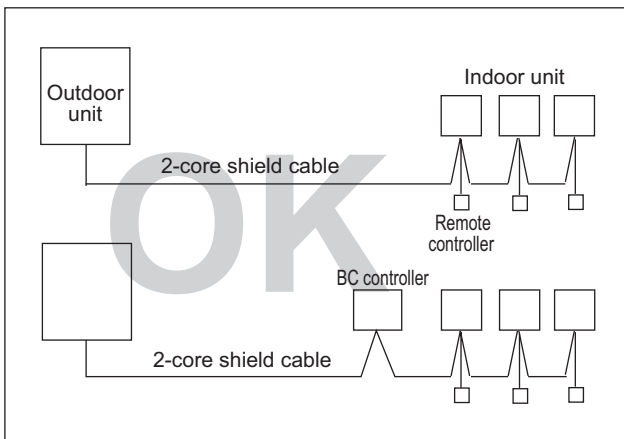

1-2. Power supply for Indoor unit and Outdoor unit

1-2-1. Electrical characteristics of Indoor unit

Symbols: MCA : Min.Circuit Amps (=1.25xFLA) FLA : Full Load Amps
 IFM :Indoor Fan Motor Output : Fan motor rated output

Model	Indoor Unit			IFM				
	Hz	Volts	Voltage range	MCA(A)	Output(kW)	FLA(A)		
PLFY-P06NLMU-E	60Hz	208 / 230V	188 to 253V	0.43 / 0.47	0.015 / 0.015	0.34 / 0.37		
PLFY-P08NLMU-E				0.43 / 0.47	0.015 / 0.015	0.34 / 0.37		
PLFY-P12NLMU-E				0.43 / 0.47	0.015 / 0.015	0.34 / 0.37		
PLFY-P15NLMU-E				0.48 / 0.53	0.015 / 0.015	0.38 / 0.42		
PLFY-P18NLMU-E				0.49 / 0.54	0.020 / 0.020	0.39 / 0.43		
PLFY-P08NCMU-E				0.29 / 0.29	0.015 / 0.015	0.23 / 0.23		
PLFY-P12NCMU-E			198 to 253V	0.35 / 0.35	0.020 / 0.020	0.28 / 0.28		
PLFY-P15NCMU-E				0.35 / 0.35	0.020 / 0.020	0.28 / 0.28		
PLFY-P12NBMU-E				0.64 / 0.64	0.050 / 0.050	0.51 / 0.51		
PLFY-P15NBMU-E				0.64 / 0.64	0.050 / 0.050	0.51 / 0.51		
PLFY-P18NBMU-E				0.64 / 0.64	0.050 / 0.050	0.51 / 0.51		
PLFY-P24NBMU-E				0.64 / 0.64	0.050 / 0.050	0.51 / 0.51		
PLFY-P30NBMU-E				0.64 / 0.64	0.050 / 0.050	0.51 / 0.51		
PLFY-P36NBMU-E				1.25 / 1.25	0.120 / 0.120	1.00 / 1.00		
PMFY-P06NBMU-E			60Hz	208 / 230V	188 to 253V	0.25 / 0.25	0.028 / 0.028	0.20 / 0.20
PMFY-P08NBMU-E						0.25 / 0.25	0.028 / 0.028	0.20 / 0.20
PMFY-P12NBMU-E	0.26 / 0.26	0.028 / 0.028				0.21 / 0.21		
PMFY-P15NBMU-E	0.33 / 0.33	0.028 / 0.028				0.26 / 0.26		
PDFY-P06NMU-E	60Hz	208 / 230V	188 to 253V	0.77 / 0.85	0.075 / 0.075	0.61 / 0.68		
PDFY-P08NMU-E				0.77 / 0.85	0.075 / 0.075	0.61 / 0.68		
PDFY-P12NMU-E				0.77 / 0.85	0.075 / 0.075	0.61 / 0.68		
PDFY-P15NMU-E				0.97 / 1.07	0.085 / 0.085	0.77 / 0.85		
PDFY-P18NMU-E				0.97 / 1.07	0.085 / 0.085	0.77 / 0.85		
PDFY-P24NMU-E				1.09 / 1.20	0.095 / 0.095	0.87 / 0.96		
PDFY-P27NMU-E				1.18 / 1.30	0.095 / 0.095	0.94 / 1.04		
PDFY-P30NMU-E				1.34 / 1.49	0.095 / 0.095	1.07 / 1.19		
PDFY-P36NMU-E				1.85 / 2.05	0.140 / 0.140	1.48 / 1.64		
PDFY-P48NMU-E				2.49 / 2.77	0.190 / 0.190	1.99 / 2.21		
PEFY-P06NMSU-E	60Hz	208 / 230V	188 to 253V	0.47 / 0.50	0.023 / 0.023	0.32 / 0.31		
PEFY-P08NMSU-E				0.47 / 0.50	0.023 / 0.023	0.41 / 0.39		
PEFY-P12NMSU-E				0.68 / 0.74	0.032 / 0.032	0.46 / 0.43		
PEFY-P15NMSU-E				1.20 / 1.33	0.130 / 0.130	0.47 / 0.45		
PEFY-P18NMSU-E				1.20 / 1.33	0.130 / 0.130	0.64 / 0.60		
PEFY-P24NMSU-E				1.57 / 1.73	0.180 / 0.180	0.88 / 0.83		
PEFY-P27NMHU-E				1.72 / 1.89	0.220 / 0.220	1.37 / 1.51		
PEFY-P30NMHU-E				2.08 / 2.29	0.230 / 0.230	1.66 / 1.83		
PEFY-P36NMHU-E				4.23 / 4.67	0.400 / 0.400	3.38 / 3.73		
PEFY-P48NMHU-E				4.23 / 4.67	0.400 / 0.400	3.38 / 3.73		
PEFY-P54NMHU-E				4.29 / 4.73	0.400 / 0.400	3.43 / 3.78		
PEFY-P72NMHU-E				5.60 / 6.18	0.650 / 0.650	4.48 / 4.94		
PEFY-P96NMHU-E				7.12 / 7.85	0.850 / 0.850	5.69 / 6.28		
PEFY-P30NMHU-E-F				60Hz	208 / 230V	188 to 253V	1.14 / 1.14	0.090 / 0.090
PEFY-P54NMHU-E-F	1.85 / 1.85	0.130 / 0.130	1.48 / 1.48					
PEFY-P72NMHU-E-F	2.20 / 2.43	0.200 / 0.200	1.76 / 1.94					
PEFY-P96NMHU-E-F	2.59 / 2.85	0.230 / 0.230	2.07 / 2.28					
PCFY-P15NKMU-E	60Hz	208 / 230V	188 to 253V	0.44 / 0.44	0.090 / 0.090	0.35 / 0.35		
PCFY-P24NKMU-E				0.52 / 0.52	0.095 / 0.095	0.41 / 0.41		
PCFY-P30NKMU-E				1.22 / 1.22	0.160 / 0.160	0.97 / 0.97		
PCFY-P36NKMU-E				1.22 / 1.22	0.160 / 0.160	0.97 / 0.97		

1. Electrical work

DATA U5

Symbols: MCA : Min.Circuit Amps (=1.25xFLA) FLA : Full Load Amps

IFM :Indoor Fan Motor

Output : Fan motor rated output

Model	Indoor Unit			IFM		
	Hz	Volts	Voltage range	MCA(A)	Output(kW)	FLA(A)
PKFY-P06NBMU-E	60Hz	208 / 230V	198 to 253V	0.19 / 0.19	0.008 / 0.008	0.15 / 0.15
PKFY-P08NBMU-E				0.19 / 0.19	0.008 / 0.008	0.15 / 0.15
PKFY-P12NHMU-E				0.38 / 0.38	0.030 / 0.030	0.30 / 0.30
PKFY-P15NHMU-E				0.38 / 0.38	0.030 / 0.030	0.30 / 0.30
PKFY-P18NHMU-E				0.38 / 0.38	0.030 / 0.030	0.30 / 0.30
PKFY-P24NKMU-E				0.37 / 0.37	0.056 / 0.056	0.29 / 0.29
PKFY-P30NKMU-E				0.54 / 0.54	0.056 / 0.056	0.43 / 0.43
PFFY-P06NEMU-E	60Hz	208 / 230V	188 to 253V	0.32 / 0.34	0.015 / 0.015	0.25 / 0.27
PFFY-P08NEMU-E				0.32 / 0.34	0.015 / 0.015	0.25 / 0.27
PFFY-P12NEMU-E				0.34 / 0.38	0.018 / 0.018	0.27 / 0.30
PFFY-P15NEMU-E				0.40 / 0.44	0.030 / 0.030	0.32 / 0.35
PFFY-P18NEMU-E				0.48 / 0.53	0.035 / 0.035	0.38 / 0.42
PFFY-P24NEMU-E				0.59 / 0.64	0.063 / 0.063	0.47 / 0.51
PFFY-P06NRMU-E	60Hz	208 / 230V	188 to 253V	0.32 / 0.34	0.015 / 0.015	0.25 / 0.27
PFFY-P08NRMU-E				0.32 / 0.34	0.015 / 0.015	0.25 / 0.27
PFFY-P12NRMU-E				0.34 / 0.38	0.018 / 0.018	0.27 / 0.30
PFFY-P15NRMU-E				0.40 / 0.44	0.030 / 0.030	0.32 / 0.35
PFFY-P18NRMU-E				0.48 / 0.53	0.035 / 0.035	0.38 / 0.42
PFFY-P24NRMU-E				0.59 / 0.64	0.063 / 0.063	0.47 / 0.51

System Y

1-2-2. Electrical characteristics of Outdoor unit at cooling mode

Symbols: MCA : Min. Circuit Amps

SC : Starting Current

RLA : Rated Load Amps

PUHY-P-T(S)HMU

Model	Unit Combination	Outdoor Units			Compressor			Fan		
		Hz	Volts	Voltage range	RLA(A)	MCA(A)	Max. Fuse(A)	Output(kW)	SC(A)	Output(kW)
PUHY-P72THMU-A(-BS)	-	60Hz	208 / 230V	188 to 253V	14.0/12.7	23/21	30	5.1	15	0.92
PUHY-P96THMU-A(-BS)	-				23.8/21.5	35/32	40	6.8	15	0.92
PUHY-P120THMU-A(-BS)	-				29.0/26.2	41/38	50	8.8	15	0.92
PUHY-P144TSHMU-A(-BS)	PUHY-P72THMU-A(-BS)				14.0/12.7	23/21	30	5.1	15	0.92
	PUHY-P72THMU-A(-BS)				14.0/12.7	23/21	30	5.1	15	0.92
PUHY-P168TSHMU-A(-BS)	PUHY-P72THMU-A(-BS)				14.0/12.7	23/21	30	5.1	15	0.92
	PUHY-P96THMU-A(-BS)				23.8/21.5	35/32	40	6.8	15	0.92
PUHY-P192TSHMU-A(-BS)	PUHY-P72THMU-A(-BS)				14.0/12.7	23/21	30	5.1	15	0.92
	PUHY-P120THMU-A(-BS)				29.0/26.2	41/38	50	8.8	15	0.92
PUHY-P216TSHMU-A(-BS)	PUHY-P96THMU-A(-BS)				23.8/21.5	35/32	40	6.8	15	0.92
	PUHY-P120THMU-A(-BS)				29.0/26.2	41/38	50	8.8	15	0.92
PUHY-P240TSHMU-A(-BS)	PUHY-P120THMU-A(-BS)				29.0/26.2	41/38	50	8.8	15	0.92
	PUHY-P120THMU-A(-BS)				29.0/26.2	41/38	50	8.8	15	0.92
PUHY-P264TSHMU-A(-BS)	PUHY-P72THMU-A(-BS)				14.0/12.7	23/21	30	5.1	15	0.92
	PUHY-P72THMU-A(-BS)				14.0/12.7	23/21	30	5.1	15	0.92
	PUHY-P120THMU-A(-BS)				29.0/26.2	41/38	50	8.8	15	0.92
PUHY-P288TSHMU-A(-BS)	PUHY-P72THMU-A(-BS)				14.0/12.7	23/21	30	5.1	15	0.92
	PUHY-P96THMU-A(-BS)				23.8/21.5	35/32	40	6.8	15	0.92
	PUHY-P120THMU-A(-BS)				29.0/26.2	41/38	50	8.8	15	0.92
PUHY-P312TSHMU-A(-BS)	PUHY-P72THMU-A(-BS)				14.0/12.7	23/21	30	5.1	15	0.92
	PUHY-P120THMU-A(-BS)				29.0/26.2	41/38	50	8.8	15	0.92
	PUHY-P120THMU-A(-BS)				29.0/26.2	41/38	50	8.8	15	0.92
PUHY-P336TSHMU-A(-BS)	PUHY-P96THMU-A(-BS)				23.8/21.5	35/32	40	6.8	15	0.92
	PUHY-P120THMU-A(-BS)				29.0/26.2	41/38	50	8.8	15	0.92
	PUHY-P120THMU-A(-BS)	29.0/26.2	41/38	50	8.8	15	0.92			
PUHY-P360TSHMU-A(-BS)	PUHY-P120THMU-A(-BS)	29.0/26.2	41/38	50	8.8	15	0.92			
	PUHY-P120THMU-A(-BS)	29.0/26.2	41/38	50	8.8	15	0.92			
	PUHY-P120THMU-A(-BS)	29.0/26.2	41/38	50	8.8	15	0.92			

System Y

1. Electrical work

Symbols: MCA : Min. Circuit Amps

SC : Starting Current RLA : Rated Load Amps

PUHY-P-Y(S)HMMU

Model	Unit Combnation	Outdoor Units						Compressor	Fan	
		Hz	Volts	Voltage range	RLA(A)	MCA(A)	Max. Fuse(A)	Output(kW)	SC(A)	Output(kW)
PUHY-P72YHMMU-A(-BS)	-	60Hz	460V	414 to 506V	6.3	11	15	5.1	7	0.92
PUHY-P96YHMMU-A(-BS)	-				10.7	16	20	6.8	7	0.92
PUHY-P120YHMMU-A(-BS)	-				13.1	19	25	8.8	7	0.92
PUHY-P144YSHMMU-A(-BS)	PUHY-P72YHMMU-A(-BS)				6.3	11	15	5.1	7	0.92
	PUHY-P72YHMMU-A(-BS)				6.3	11	15	5.1	7	0.92
PUHY-P168YSHMMU-A(-BS)	PUHY-P72YHMMU-A(-BS)				6.3	11	15	5.1	7	0.92
	PUHY-P96YHMMU-A(-BS)				10.7	16	20	6.8	7	0.92
PUHY-P192YSHMMU-A(-BS)	PUHY-P72YHMMU-A(-BS)				6.3	11	15	5.1	7	0.92
	PUHY-P120YHMMU-A(-BS)				13.1	19	25	8.8	7	0.92
PUHY-P216YSHMMU-A(-BS)	PUHY-P96YHMMU-A(-BS)				10.7	16	20	6.8	7	0.92
	PUHY-P120YHMMU-A(-BS)				13.1	19	25	8.8	7	0.92
PUHY-P240YSHMMU-A(-BS)	PUHY-P120YHMMU-A(-BS)				13.1	19	25	8.8	7	0.92
	PUHY-P120YHMMU-A(-BS)				13.1	19	25	8.8	7	0.92
PUHY-P264YSHMMU-A(-BS)	PUHY-P72YHMMU-A(-BS)				6.3	11	15	5.1	7	0.92
	PUHY-P72YHMMU-A(-BS)				6.3	11	15	5.1	7	0.92
	PUHY-P120YHMMU-A(-BS)				13.1	19	25	8.8	7	0.92
PUHY-P288YSHMMU-A(-BS)	PUHY-P72YHMMU-A(-BS)				6.3	11	15	5.1	7	0.92
	PUHY-P96YHMMU-A(-BS)				10.7	16	20	6.8	7	0.92
	PUHY-P120YHMMU-A(-BS)				13.1	19	25	8.8	7	0.92
PUHY-P312YSHMMU-A(-BS)	PUHY-P72YHMMU-A(-BS)				6.3	11	15	5.1	7	0.92
	PUHY-P120YHMMU-A(-BS)				13.1	19	25	8.8	7	0.92
	PUHY-P120YHMMU-A(-BS)				13.1	19	25	8.8	7	0.92
PUHY-P336YSHMMU-A(-BS)	PUHY-P96YHMMU-A(-BS)				10.7	16	20	6.8	7	0.92
	PUHY-P120YHMMU-A(-BS)				13.1	19	25	8.8	7	0.92
	PUHY-P120YHMMU-A(-BS)	13.1	19	25	8.8	7	0.92			
PUHY-P360YSHMMU-A(-BS)	PUHY-P120YHMMU-A(-BS)	13.1	19	25	8.8	7	0.92			
	PUHY-P120YHMMU-A(-BS)	13.1	19	25	8.8	7	0.92			
	PUHY-P120YHMMU-A(-BS)	13.1	19	25	8.8	7	0.92			

System Y

1-3. Power cable specifications

Thickness of wire for main power supply, ON / OFF capacities

3-phase 3-wire, 208/230V,60Hz		Minimum wire thickness (mm ² / AWG)			Switch (A)		Breaker for wiring (NFB)	Breaker for current leakage
		Main cable	Branch	Ground	Capacity	Fuse		
PUHY-P-THMU-A	P72	5.3/10	-	5.3/10	30	30	30	30A 30mA or 100mA 0.1sec. or less
	P96	13.3/6	-	13.3/6	40	40	40	40A 30mA or 100mA 0.1sec. or less
	P120	13.3/6	-	13.3/6	50	50	50	50A 100mA 0.1sec. or less
Indoor unit		2.1/14	2.1/14	2.1/14	15	15	15	20A 30mA or 100mA 0.1sec. or less

3-phase 3-wire, 460V,60Hz		Minimum wire thickness (mm ² / AWG)			Switch (A)		Breaker for wiring (NFB)	Breaker for current leakage
		Main cable	Branch	Ground	Capacity	Fuse		
PUHY-P-YHMU-A	P72	2.1/14	-	2.1/14	15	15	15	15A 30mA or 100mA 0.1sec. or less
	P96	3.3/12	-	3.3/12	20	20	20	20A 30mA or 100mA 0.1sec. or less
	P120	5.3/10	-	5.3/10	25	25	25	25A 30mA or 100mA 0.1sec. or less
Indoor unit		2.1/14	2.1/14	2.1/14	15	15	15	20A 30mA or 100mA 0.1sec. or less

1. Use a separate power supply for the outdoor unit and indoor unit.
2. Bear in mind ambient conditions (ambient temperature, direct sunlight, rain water, etc.) when proceeding with the wiring and connections.
3. The wire size is the minimum value for metal conduit wiring. The power cord size should be 1 rank thicker consideration of voltage drops.
Make sure the power-supply voltage does not drop more than 10 %.
4. Specific wiring requirements should adhere to the wiring regulations of the region.
5. Power supply cords of parts of appliances for outdoor use shall not be lighter than polychloroprene sheathed flexible cord (design 245 IEC57). For example, use wiring such as YZW.
6. A switch with at least 3 mm [1 / 8 in] contact separation in each pole shall be provided by the Air conditioner installation.

⚠ WARNING

- Be sure to use specified wires to connect so that no external force is imparted to terminal connections. If connections are not fixed firmly, it may cause heating or fire.
- Be sure to use the appropriate type of overcurrent protection switch. Note that generated overcurrent may include some amount of direct current.

⚠ CAUTION

- A breaker for current leakage must be attached to the power supply. If no earth leakage breaker is installed, it may cause an electric shock.
- Do not use anything other than breaker and fuse with correct capacity. Using fuse and wire or copper wire with too large capacity may cause a malfunction of unit or fire.

1-4. Power supply examples

The local standards and/or regulations is applicable at a higher priority.

1-4-1. PUHY-P72, 96, 120THMU/YHMU

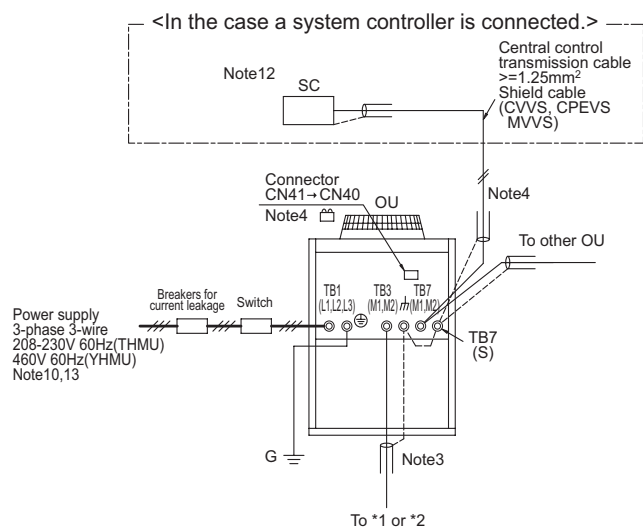

- Note:
- The transmission cable is not-polarity double-wire.
 - Symbol © means a screw terminal for wiring.
 - The shield wire of transmission cable should be connected to the grounding terminal at Outdoor unit. All shield wire of M-Net transmission cable among Indoor units should be connected to the S terminal at Indoor unit or all shield wire should be connected together. The broken line at the scheme means shield wire.
 - When the Outdoor unit connected with system controller, power-supply to TB7 of the outdoor unit(s) is needed. The connector change from CN41 to CN40 at one of the outdoor units will enable the outdoor unit to supply power to TB7, or an extra power supplying unit PAC-SC50KUA should be used. The transmission cable (above 1.25mm², shielded, CVVS/CPEVS/MVVS) among Outdoor units and system controllers is called central control transmission cable. The shield wire of the central control transmission cable must be grounded at the Outdoor unit whose CN41 is changed to CN40.
 - MA R/C transmission cable (0.3-1.25mm²) must be less than 200m in length, while ME R/C transmission cable (0.3-1.25mm²) must be less than 10m in length. But transmission cable to the ME R/C can be extend using a M-NET cable (>=1.25mm²) when the length is counted in the M-Net length. Both Compact MA and ME R/C transmission cables size 0.75-1.25mm² in thickness.
 - MA remote controller and ME remote controller should not be grouped together.
 - If using 1 or 2 (main/sub) MA remote controller to control more than 1 Indoor unit, use MA transmission cable to connect all the TB15 terminals of the Indoor units. It is called "Grouping".
If using 1 or 2 (main/sub) ME remote controller control more than 1 indoor unit, set address to Indoor unit and ME remote controller. For the method, refer to 2-4. "Address Setting".
 - Indoor board consumes power from TB3. The power balance should be considered according to System Design 2-3 "System configuration restrictions".
 - If Transmission booster is needed, be sure to connect the shield wires to the both sides to the booster.
 - The critical current for choosing power source equipment is approximate 1.4 times of total rated current of the Outdoor unit(s).
 - Numbers shown with () indicates a diameter of the compact remote controller.
 - When System controller (SC) is connected to the system, turn the SW2-1 on.
 - The phases of electricity power must be confirmed to be right used. Phase-reverse, or phase-missing could break the controllers.

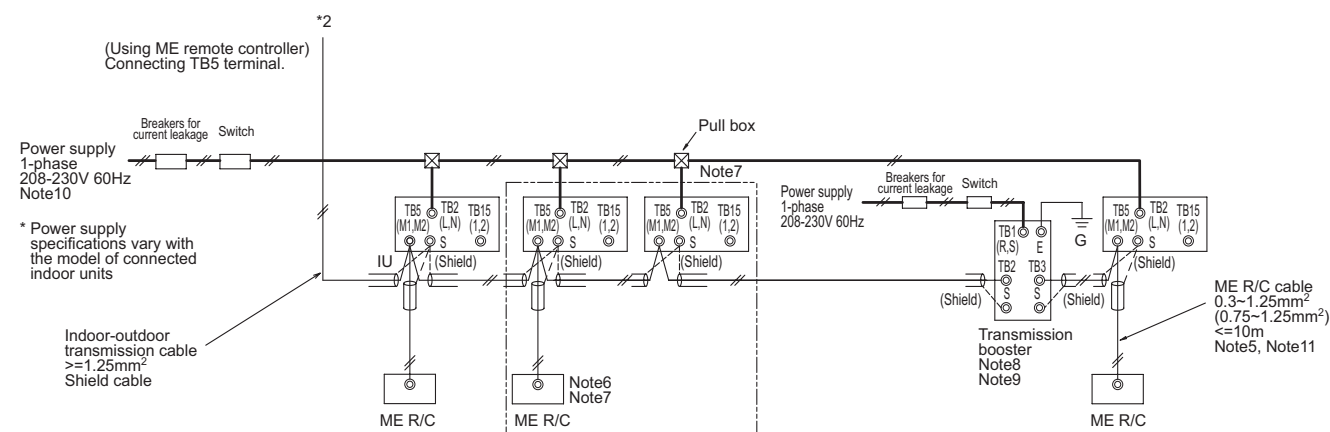
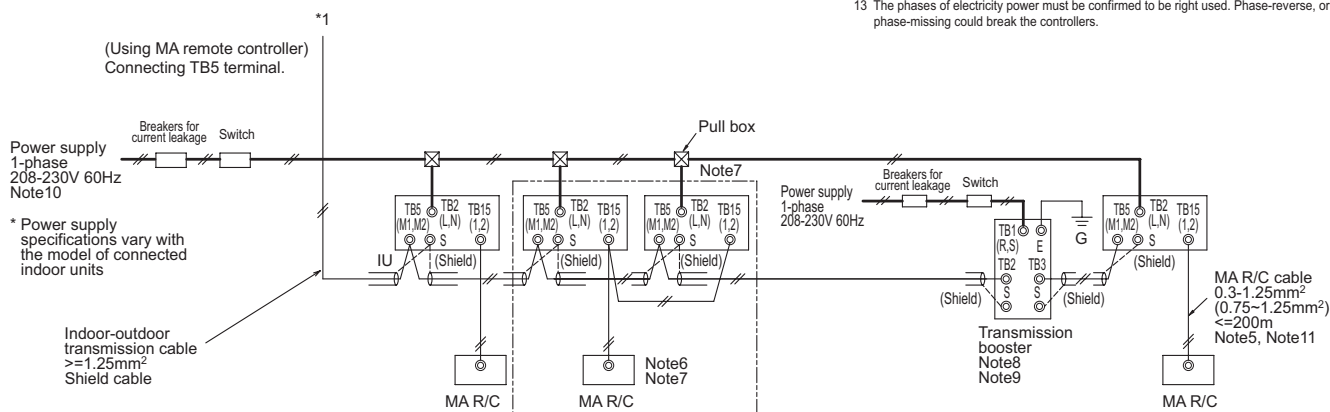

Symbol	Model	Breakers for current leakage *1, *2	Switch			Minimum Wire thickness		
			BC <A>	OCP*3 <A>	Switch (NFB) <A>	Power wire <mm ² /AWG>	G wire <mm ² /AWG>	
BC	Breaker capacity	PUHY-P72THMU	30A 30mA or 100mA 0.1sec. or less	30	30	30	5.3/10	5.3/10
OCP	Over-current protector	PUHY-P96THMU	40A 30mA or 100mA 0.1sec. or less	40	40	40	5.3/10	5.3/10
NFB	Non-fuse breaker	PUHY-P120THMU	50A 100mA 0.1sec. or less	50	50	50	13.3/6	13.3/6
OU	Outdoor unit	PUHY-P72YHMU	15A 30mA or 100mA 0.1sec. or less	15	15	15	2.1/14	2.1/14
IU	Indoor unit	PUHY-P96YHMU	20A 30mA or 100mA 0.1sec. or less	20	20	20	3.3/12	3.3/12
SC	System controller	PUHY-P120YHMU	25A 30mA or 100mA 0.1sec. or less	25	25	25	5.3/10	5.3/10
MA R/C	MA remote controller							
ME R/C	ME remote controller							

*1 The breakers for current leakage should support Inverter circuit. (e.g. Mitsubishi Electric's NV-C series or equivalent).

*2 Breakers for current leakage should combine using of switch.

*3 It shows data for B-type fuse of the breaker for current leakage.

The local standards and/or regulations is applicable at a higher priority.
 1-4-2. PUHY-P144, 168, 192, 216, 240TSHMU/YSHMU

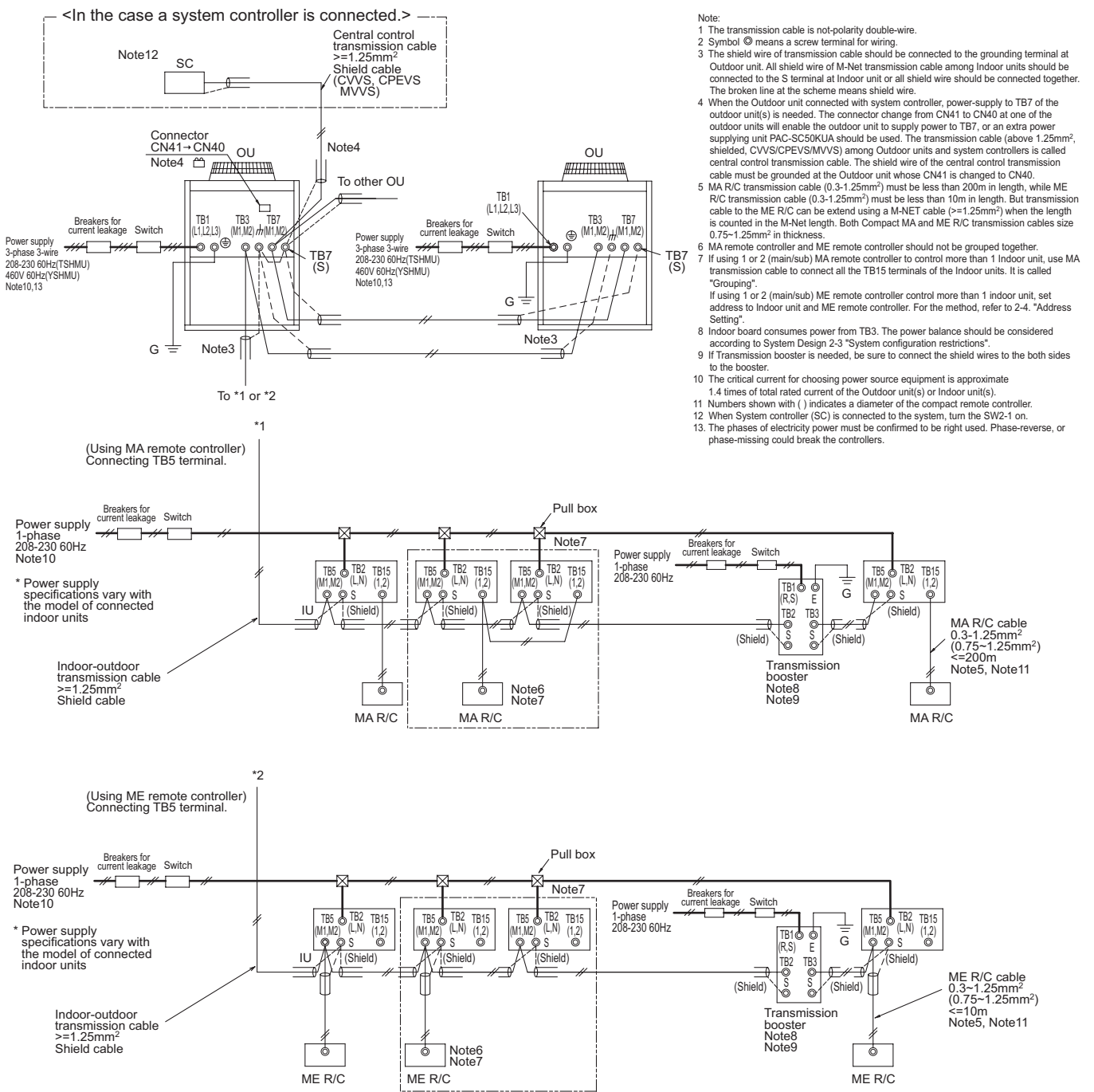

Symbol	Model	Breakers for current leakage *1, *2	Switch			Minimum Wire thickness		
			BC <A>	OCP*3 <A>	Switch (NFB) <A>	Power wire <mm ² /AWG>	G wire <mm ² /AWG>	
BC	Breaker capacity	PUHY-P72THMU	30A 30mA or 100mA 0.1sec. or less	30	30	30	5.3/10	5.3/10
OCP	Over-current protector	PUHY-P96THMU	40A 30mA or 100mA 0.1sec. or less	40	40	40	5.3/10	5.3/10
NFB	Non-fuse breaker	PUHY-P120THMU	50A 100mA 0.1sec. or less	50	50	50	13.3/6	13.3/6
OU	Outdoor unit	PUHY-P72YHMU	15A 30mA or 100mA 0.1sec. or less	15	15	15	2.1/14	2.1/14
IU	Indoor unit	PUHY-P96YHMU	20A 30mA or 100mA 0.1sec. or less	20	20	20	3.3/12	3.3/12
SC	System controller	PUHY-P120YHMU	25A 30mA or 100mA 0.1sec. or less	25	25	25	5.3/10	5.3/10

*1 The breakers for current leakage should support Inverter circuit. (e.g. Mitsubishi Electric's NV-C series or equivalent).

*2 Breakers for current leakage should combine using of switch.

*3 It shows data for B-type fuse of the breaker for current leakage.

The local standards and/or regulations is applicable at a higher priority.
 1-4-3. PUHY-P264, 288, 312, 336, 360TSHMU/YSHMU

System Y

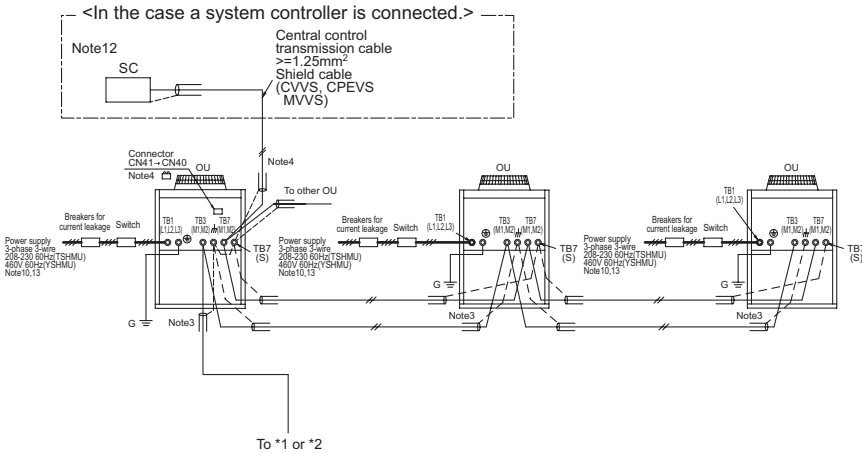

- Note:
- The transmission cable is not-polarity double-wire.
 - Symbol Ⓞ means a screw terminal for wiring.
 - The shield wire of transmission cable should be connected to the grounding terminal at Outdoor unit. All shield wire of M-Net transmission cable among Indoor units should be connected to the S terminal at Indoor unit or all shield wire should be connected together. The broken line at the scheme means shield wire.
 - When the Outdoor unit connected with system controller, power-supply to TB7 of the outdoor unit(s) is needed. The connector change from CN41 to CN40 at one of the outdoor units will enable the outdoor unit to supply power to TB7, or an extra power supplying unit PAC-SC50KUA should be used. The transmission cable (above 1.25mm², shielded, CVVS/CPEVS/MVVS) among Outdoor units and system controllers is called central control transmission cable. The shield wire of the central control transmission cable must be grounded at the Outdoor unit whose CN41 is changed to CN40.
 - MA R/C transmission cable (0.3-1.25mm²) must be less than 200m in length, while ME R/C transmission cable (0.3-1.25mm²) must be less than 10m in length. But transmission cable to the ME R/C can be extend using a M-NET cable (>=1.25mm²) when the length is counted in the M-Net length. Both Compact MA and ME R/C transmission cables size 0.75-1.25mm² in thickness.
 - MA remote controller and ME remote controller should not be grouped together.
 - If using 1 or 2 (main/sub) MA remote controller to control more than 1 Indoor unit, use MA transmission cable to connect all the TB15 terminals of the Indoor units. It is called "Grouping".
If using 1 or 2 (main/sub) ME remote controller control more than 1 indoor unit, set address to Indoor unit and ME remote controller. For the method, refer to 2-4. "Address Setting".
 - Indoor board consumes power from TB3. The power balance should be considered according to System Design 2-3 "System configuration restrictions".
 - If Transmission booster is needed, be sure to connect the shield wires to the both sides to the booster.
 - The critical current for choosing power source equipment is approximate 1.4 times of total rated current of the Outdoor unit(s) or Indoor unit(s).
 - Numbers shown with () indicates a diameter of the compact remote controller.
 - When System controller (SC) is connected to the system, turn the SW2-1 on.
 - The phases of electricity power must be confirmed to be right used. Phase-reverse, or phase-missing could break the controllers.

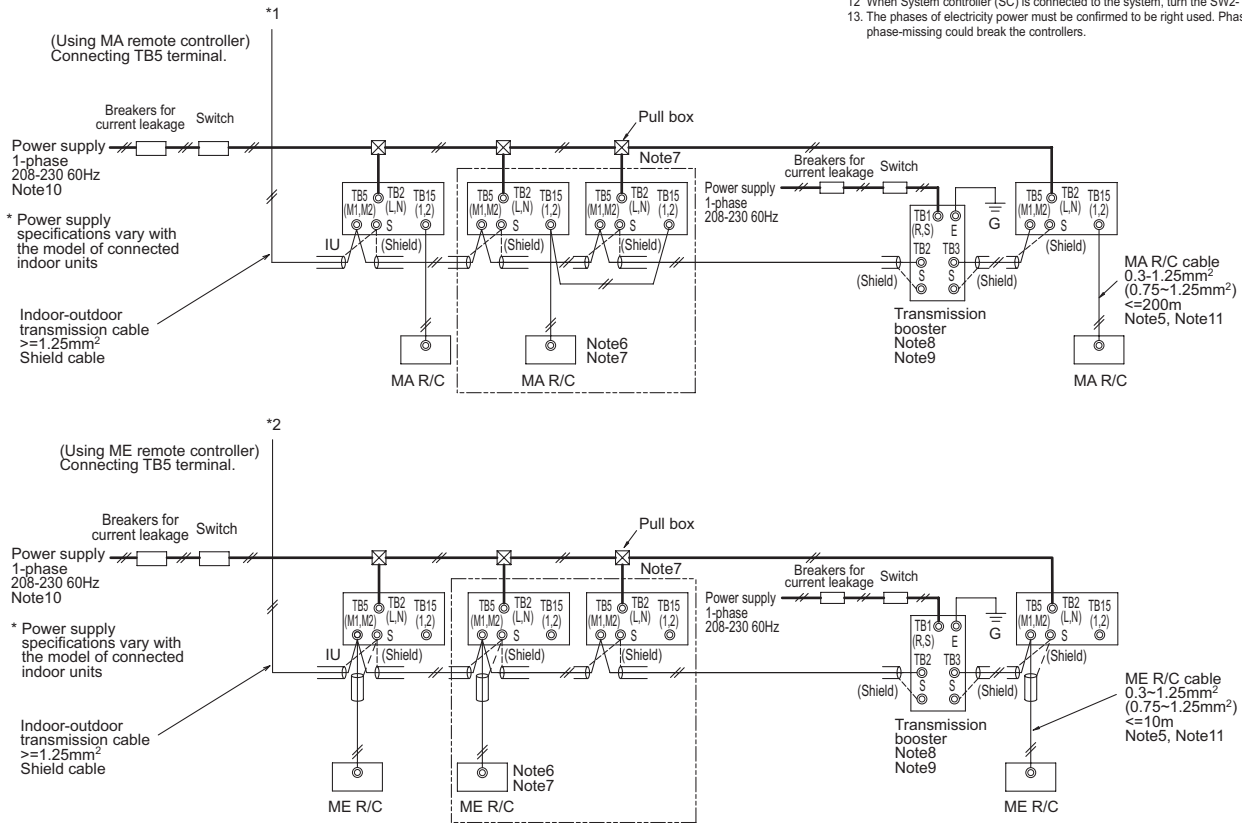

Symbol	Model	Breakers for current leakage *1, *2	Switch			Minimum Wire thickness		
			BC <A>	OCP*3 <A>	Switch (NFB) <A>	Power wire <mm ² /AWG>	G wire <mm ² /AWG>	
BC	Breaker capacity	PUHY-P72THMU	30A 30mA or 100mA 0.1sec. or less	30	30	30	5.3/10	5.3/10
OCP	Over-current protector	PUHY-P96THMU	40A 30mA or 100mA 0.1sec. or less	40	40	40	5.3/10	5.3/10
NFB	Non-fuse breaker	PUHY-P120THMU	50A 100mA 0.1sec. or less	50	50	50	13.3/6	13.3/6
OU	Outdoor unit	PUHY-P72YHMU	15A 30mA or 100mA 0.1sec. or less	15	15	15	2.1/14	2.1/14
IU	Indoor unit	PUHY-P96YHMU	20A 30mA or 100mA 0.1sec. or less	20	20	20	3.3/12	3.3/12
SC	System controller	PUHY-P120YHMU	25A 30mA or 100mA 0.1sec. or less	25	25	25	5.3/10	5.3/10
MA R/C	MA remote controller							
ME R/C	ME remote controller							

*1 The breakers for current leakage should support Inverter circuit. (e.g. Mitsubishi Electric's NV-C series or equivalent).
 *2 Breakers for current leakage should combine using of switch.
 *3 It shows data for B-type fuse of the breaker for current leakage.

2-1. Transmission cable length limitation

2-1-1. Using MA Remote controller

Long transmission cable causes voltage down, therefore, the length limitation should be obeyed to secure proper transmission.

Max. length via Outdoor (M-NET cable)	$L1+L2+L3+L4, L1+L2+L6+L7, L3+L4+L6+L7$	$\leq 500\text{m}[1640\text{ft.}]$	1.25mm ² [AWG16] or thicker
Max. length to Outdoor (M-NET cable)	$L1+L8, L3+L4, L6, L2+L6+L8, L7$	$\leq 200\text{m}[656\text{ft.}]$	1.25mm ² [AWG16] or thicker
Max. length from MA to Indoor	$a1+a2, a1+a2+a3+a4$	$\leq 200\text{m}[656\text{ft.}]$	0.3-1.25 mm ² [AWG22-16]
24VDC to AG-150A	n	$\leq 50\text{m}[164\text{ft.}]$	0.75-2.0 mm ² [AWG18-14]

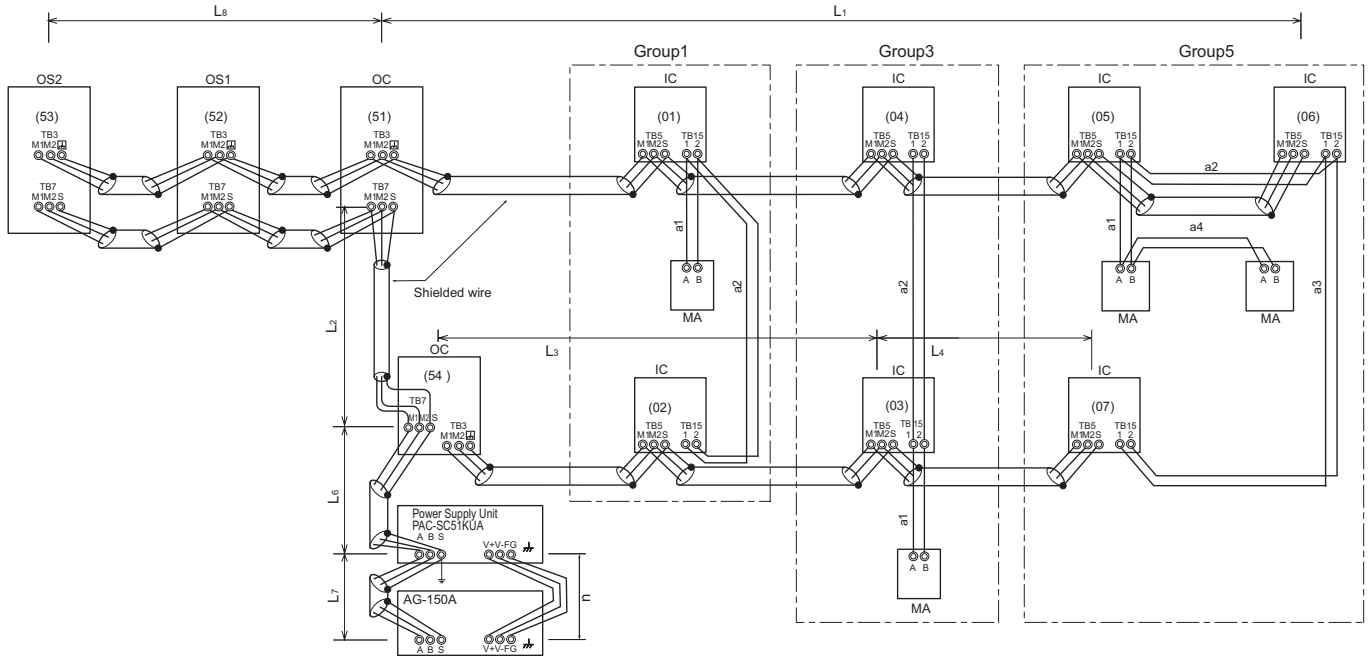

OC, OS1, OS2 : Outdoor unit controller; IC: Indoor unit controller; MA: MA remote controller

2-1-2. Using ME Remote controller

Long transmission cable causes voltage down, therefore, the length limitation should be obeyed to secure proper transmission.

Max. length via Outdoor (M-NET cable)	$L1+L2+L3+L4, L1+L2+L6+L7, L1+L2+L3+L5, L3+L4+L6+L7$	$\leq 500\text{m}[1640\text{ft.}]$	1.25mm ² [AWG16] or thicker
Max. length to Outdoor (M-NET cable)	$L1+L8, L3+L4, L6, L2+L6+L8, L7, L3+L5$	$\leq 200\text{m}[656\text{ft.}]$	1.25mm ² [AWG16] or thicker
Max. length from ME to Indoor	$e1, e2, e3, e4$	$\leq 10\text{m}[32\text{ft.}]^*1$	0.3-1.25 mm ² [AWG22-16] *1
24VDC to AG-150A	n	$\leq 50\text{m}[164\text{ft.}]$	0.75-2.0 mm ² [AWG18-14]

*1. If the length from ME to Indoor exceed 10m, use 1.25 mm² [AWG16] shielded cable, but the total length should be counted into Max. length via Outdoor.

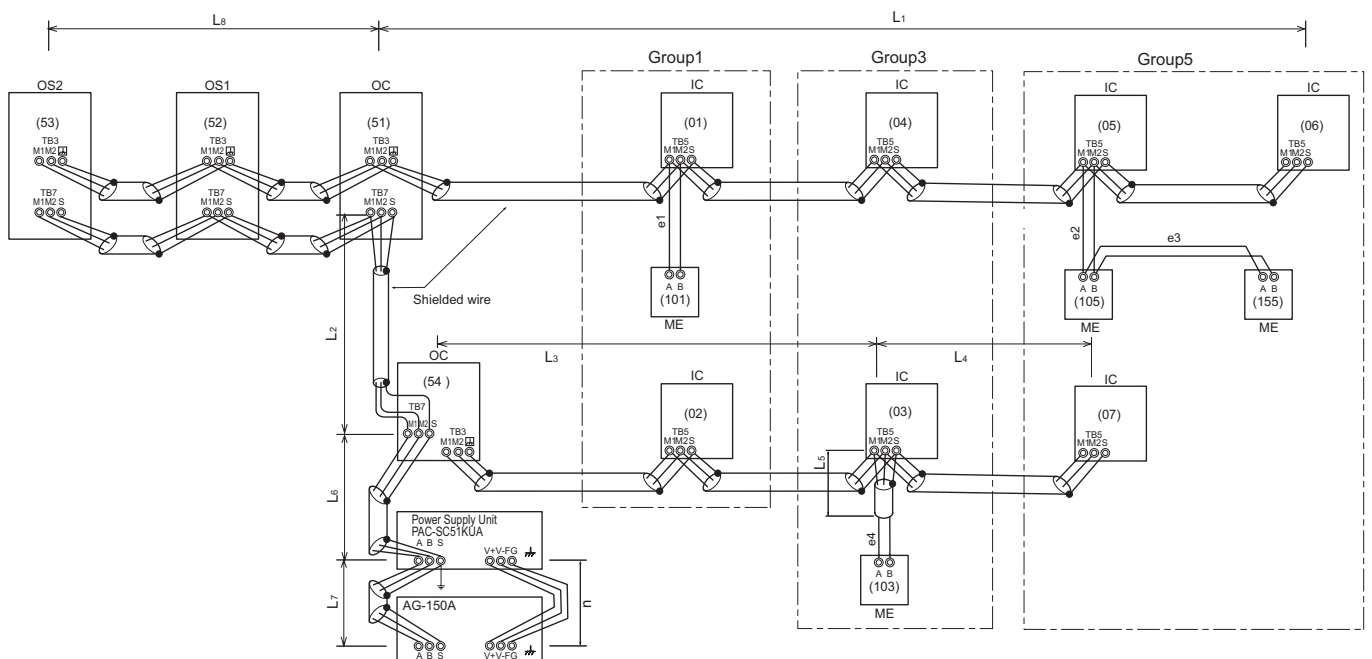

OC, OS1, OS2: Outdoor unit controller; IC: Indoor unit controller; ME: ME remote controller

2-2. Transmission cable specifications

	Transmission cables (Li)	ME Remote controller cables	MA Remote controller cables
Type of cable	Shielding wire (2-core) CVVS, CPEVS or MVVS	Sheathed 2-core cable (unshielded) CVV	
Cable size	More than 1.25mm ² [AWG16]	0.3~1.25mm ² [AWG22~16] (0.75~1.25mm ² [AWG18~16])*1	0.3~1.25mm ² [AWG22~16] (0.75~1.25mm ² [AWG18~16])*1
Remarks	—	When 10m [32ft] is exceeded, use cables with the same specification as transmission cables.	Max length : 200m [656ft]

*1 Connected with simple remote controller.

CVVS, MVVS : PVC insulated PVC jacketed shielded control cable
 CPEVS : PE insulated PVC jacketed shielded communication cable
 CVV : PV insulated PVC sheathed control cable

2-3. System configuration restrictions

2-3-1. Common restrictions for the CITY MULTI system

For each Outdoor unit, the maximum connectable quantity of Indoor unit is specified at its Specifications table.

- A) 1 Group of Indoor units can have 1-16 Indoor units;
- B) Maximum 2 remote controllers for 1 Group; (MA/ME remote controllers cannot be present together in 1group.)
- C) 1 LOSSNAY unit can interlock maximum 16 Indoor units; 1 Indoor unit can interlock only 1 LOSSNAY unit.
- D) Maximum 3 System controllers are connectable when connecting to TB3 of the Outdoor unit.
- E) Maximum 3 System controllers are connectable when connecting to TB7 of the Outdoor unit, if the transmission power is supplied by the Outdoor unit.
- F) 4 System controllers or more are connectable when connecting to TB7 of the Outdoor unit, if the transmission power is supplied by the power supply unit PAC-SC50(51)KUA. Details refer to 2-3-3-C.

*System controller connected as described in D) and E) would have a risk that the failure of connected Outdoor unit would stop power supply to the System controller.

2-3-2. Ensuring proper communication power for M-NET

In order to ensure proper communication among Outdoor unit, Indoor unit, LOSSNAY and Controllers, the transmission power situation for the M-NET should be observed. In some cases, Transmission booster should be used. Taking the power consumption index of Indoor unit sized P06-P54 as 1, the equivalent power consumption index and supply capability index of others are listed at Table 2-3-1 and Table 2-3-2.

Table 2-3-1 The equivalent power consumption by index Indoor units, LOSSNAY, controllers

Indoor, OA unit	Indoor unit	BC controller	MA RC.LOSSNAY	ME Remote Contr.	Timers, System Contr.	ON/OFF Contr.	MN Converter		
Sized P06-P54	Sized P72,P96	CMB	PAR-21MAA PAC-YT51CRA(B) PAR-FA32MA LGH-RX-E PZ-41SLB	PAR-F27MEA PZ-52SF	PAC-SF44SRA PAC-YT34STA G-50A AG-150A	GB-50A	PAC-YT40ANRA	CMS -MNF-B	CMS -MNG-E
1	2	2	0	1/4	1/2	3	1	1/2	2

*RC : Remote Controller

Table 2-3-2 The equivalent power supply capability index of Trans.Booster, Power supply unit, Connector TB3, TB7 of Outdoor unit.

Transmission Booster	Power supply unit		Outdoor unit	Outdoor unit
PAC-SF46EPA	PAC-SC50KUA	PAC-SC51KUA	Connector TB3 and TB7 total *	Connector TB7 only
25	6	5	32	6

*If PAC-SC50(51)KUA is used to supply power at TB7 side, no power supply need from Outdoor unit at TB7, Connector TB3 itself will therefore have 32. Not applicable to the PUMY model.

With the equivalent power consumption values in Table 2-3-1 and Table 2-3-2, PAC-SF46EPA can be designed into the air-conditioner system to ensure proper system communication according to 2-3-2-A, B, C.

2-3-2-A) Firstly, count from TB3 at TB3 side the total quantity of Indoor units and ME remote controller, Timers and System controllers. If the total quantity reaches 40, a PAC-SF46EPA should be set. In this case, Indoor unit sized P72, 96 is counted as 2 Indoor units, but MA remote controller(s), LOSSNAY is NOT counted.

2-3-2-B) Secondly, count from TB7 side to TB3 side the total transmission power consumption index. If the total power consumption reaches 32, a PAC-SF46EPA should be set. Yet, if a PAC-SC50(51)KUA is used to supply power at TB7 side, count from index TB3 side only.

2-3-2-C) Thirdly, count from TB7 at TB7 side the total transmission power consumption index, If the total power consumption reaches 6, a PAC-SF46EPA should be set.

■ System example

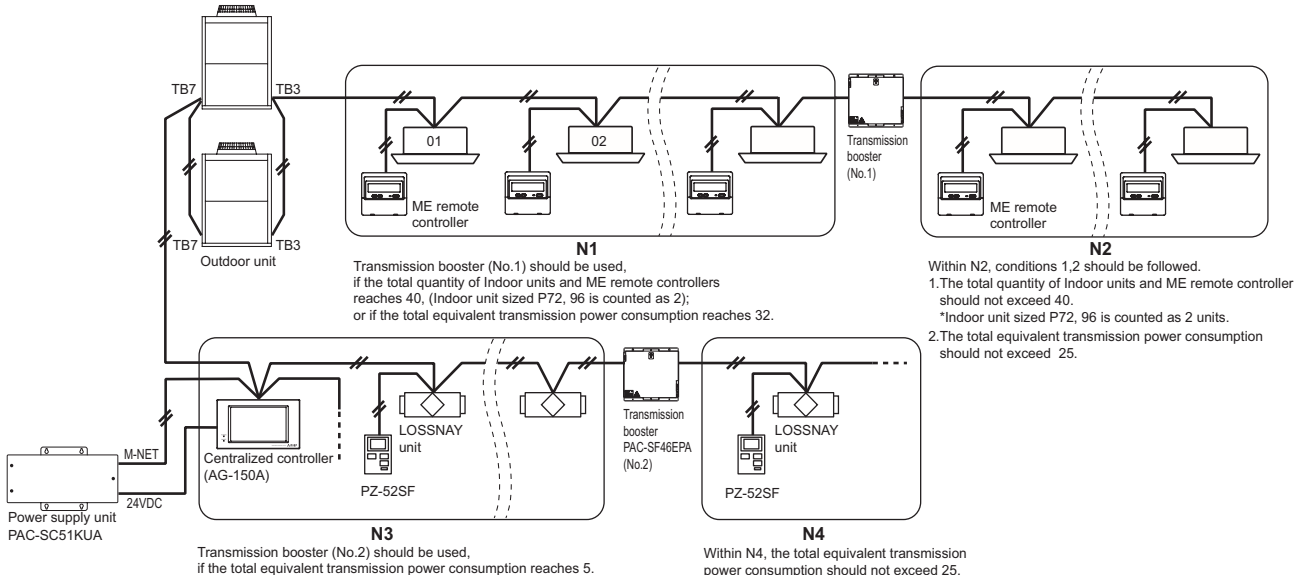

2-3-3. Ensuring proper power supply to System controller

The power to System controller (excluding LMAP03-U) is supplied via M-NET transmission line. M-NET transmission line at TB7 side is called Central control transmission line while one at TB3 side is called Indoor-Outdoor transmission line. There are 3 ways to supply power to the System controller .

- A) Connecting to TB3 of the Outdoor unit and receiving power from the Outdoor unit.
- B) Connecting to TB7 of the Outdoor unit and receiving power from the Outdoor unit.
- C) Connecting to TB7 of the Outdoor unit but receiving power from power supply unit PAC-SC51KUA.

2-3-3-A. When connecting to TB3 of the Outdoor unit and receiving power from the Outdoor unit.

Maximum 3 System controllers can be connected to TB3. If there is more than 1 Outdoor unit, it is necessary to replace power supply switch connector CN41 with CN40 on one Outdoor unit.

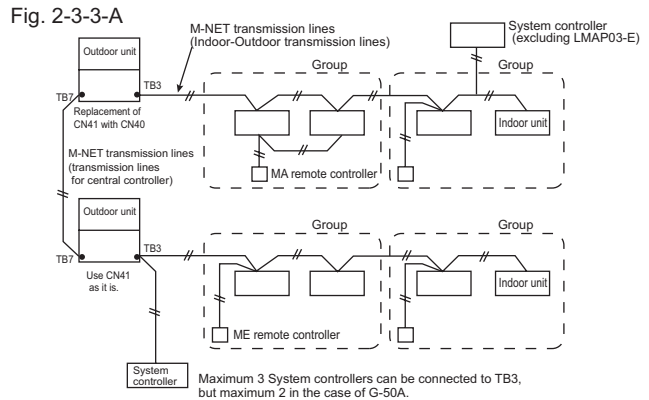

2-3-3-B. When connecting to TB7 of the Outdoor unit and receiving power from the Outdoor unit.

Maximum 3 System controllers can be connected to TB7 and receiving power from the Outdoor unit. It is necessary to replace power supply switch connector CN41 with CN40 on one Outdoor unit.

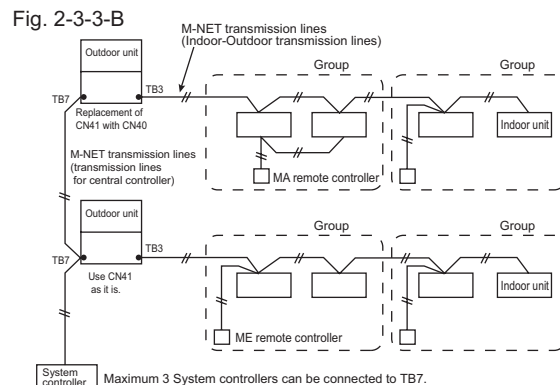

2-3-3-C. When connecting to TB7 of the Outdoor unit but receiving power from PAC-SC51KUA.

When using PAC-SC51KUA to supply transmission power, the power supply connector CN41 on the Outdoor units should be kept as it is. It is also a factory setting. 1 PAC-SC51KUA supports maximum 1 AG-150A unit due to the limited power 24VDC at its TB3. However, 1 PAC-SC51KUA supplies transmission power at its TB2 equal to 5 Indoor units, which is referable at Table 2-3-2.

If PZ-52SF, Timers, System controller, ON/OFF controller connected to TB7 consume transmission power more than 5 (Indoor units), Transmission booster PAC-SF46EPA is needed. PAC-SF46EPA supplies transmission power equal to 25 Indoor units.

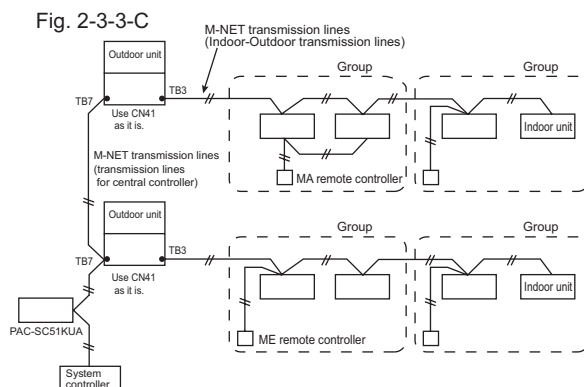

CAUTION

AG-150A / G-50A is recommended to connect to TB7 because it performs back-up to a number of data. In an air conditioner system has more than 1 Outdoor units, AG-150A / G-50A receiving transmission power through TB3 or TB7 on one of the Outdoor units would have a risk that the connected Outdoor unit failure would stop power supply to AG-150A / G-50A, and disrupt the whole system. When applying apportioned electric power function, AG-150A / G-50A is necessary to connected to TB7 and has its own power supply unit PAC-SC51/50KUA.*

*Power supply unit PAC-SC50KUA is for G-50A, and PAC-SC51KUA is for AG-150A.

2-3-4. Power supply to LM adapter LMAP03U

1-phase 208-230V AC power supply is needed.

The power supply unit PAC-SC51KUA is not necessary when connecting only the LMAP03U. Yet, make sure to change the power supply changeover connector CN41 to CN40 on the LM adapter.

2-4. Address setting

2-4-1. Switch operation

In order to constitute CITY MULTI in a complete system, switch operation for setting the unit address No. and connection No. is required.

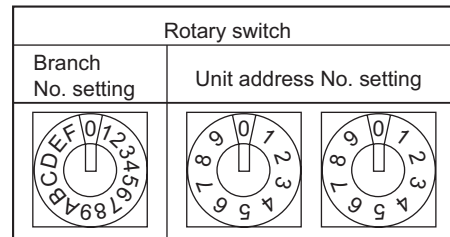

① Address No. of outdoor unit, indoor unit and remote controller.

The address No. is set at the address setting board.

In the case of R2 system, it is necessary to set the same No. at the branch No. switch of indoor unit as that of the BC controller connected. (When connecting two or more branches, use the lowest branch No.)

② Caution for switch operations

- Be sure to shut off power source before switch setting. If operated with power source on, switch can not operate properly.
- No units with identical unit address shall exist in one whole air conditioner system. If set erroneously, the system can not operate.

③ MA remote controller

- When connecting only one remote controller to one group, it is always the main remote controller. When connecting two remote controllers to one group, set one remote controller as the main remote controller and the other as the sub remote controller.
- The factory setting is "Main".

PAR-21MAA

The MA remote controller does not have the switches listed above.
Refer to the installation manual for the function setting.

























PAC-YT51CRB

Setting the dip switches

There are switches on the front of the remote controller. Remote controller Main/Sub and other function settings are performed using these switches. Ordinarily, only change the Main/Sub setting of SW1. (The factory settings are all "ON".)

SW No	SW contents Main	ON	OFF	Comment
1	Remote controller Main/Sub setting	Main	Sub	Set one of the two remote controllers at one group to "Main"
2	Temperature display units setting	Celsius	Fahrenheit	When the temperature is displayed in [Fahrenheit], set to "No".
3	Cooling/heating display in AUTO mode	Yes	No	When you do not want to display "Cooling" and "Heating" in the Auto mode, set to "No".

2-4-2. Rule of setting address

Unit	Address setting	Example	Note	
Indoor unit	01 ~ 50	 	Use the most recent address within the same group of indoor units. Make the indoor units address connected to the BC controller (Sub) larger than the indoor units address connected to the BC controller (Main). If applicable, set the sub BC controllers in an PURY system in the following order: (1) Indoor unit to be connected to the BC controller (Main) (2) Indoor unit to be connected to the BC controller (No.1 Sub) (3) Indoor unit to be connected to the BC controller (No.2 Sub) Set the address so that (1)<(2)<(3)	
Outdoor unit	51 ~ 99, 100 (Note1)	 	The smallest address of indoor unit in same refrigerant system + 50 Assign sequential address numbers to the outdoor units in one refrigerant circuit system. OC and OS are automatically detected. (Note 2) * Please reset one of them to an address between 51 and 99 when two addresses overlap. * The address automatically becomes "100" if it is set as "01~50"	
BC controller (Main)	52 ~ 99, 100	 	The address of outdoor unit + 1 * Please reset one of them to an address between 51 and 99 when two addresses overlap. * The address automatically becomes "100" if it is set as "01~50"	
BC controller (Sub)	52 ~ 99, 100	 	Lowest address within the indoor units connected to the BC controller (Sub) plus 50.	
Local remote controller	ME, LOSSNAY Remote controller (Main)	101 ~ 150 1 Fixed	 	The smallest address of indoor unit in the group + 100 * The place of "100" is fixed to "1"
	ME, LOSSNAY Remote controller (Sub)	151 ~ 199, 200 1 Fixed	 	The address of main remote controller + 50 * The address automatically becomes "200" if it is set as "00"
System controller	Group remote controller	201 ~ 250 2 Fixed	 	The smallest group No. to be managed + 200
	System remote controller	000, 201 ~ 250	  	
	ON/OFF remote controller	000, 201 ~ 250	  	The smallest group No. to be managed + 200 * The smallest group No. to be managed is changeable.
	AG-150A G-50A GB-50A	000, 201 ~ 250	  	
	LMAP03U	201 ~ 250 2 Fixed	 	

Note1: To set the address to "100", set it to "50"

Note2: Outdoor units OC and OS in one refrigerant circuit system are automatically detected.

OC and OS are ranked in descending order of capacity. If units are the same capacity, they are ranked in ascending order of their address.

2-4-3. System examples

Factory setting

Original switch setting of the outdoors, indoors, controllers and LMAP at shipment is as follows.

- Outdoor unit : Address: 00, CN41: U (Jumper), DipSW2-1: OFF
- Indoor unit : Address: 00
- ME remote controller : Address: 101
- LMAP : Address: 247, CN41: U (Jumper), DipSW1-2: OFF

Setting at the site

- DipSW2-1(Outdoor) : When the System Controller is used, all the Dip SW2-1 at the outdoor units should be set to "ON". * Dip SW2-1 remains OFF when only LMAP03U is used.
- DipSW1-2(LMAP) : When the LMAP is used together with System Controller, DipSW1-2 at the LMAP should be set to "ON".
- CN40/CN41 : Change jumper from CN41 to CN 40 at outdoor control board will activate central transmission power supply to TB7;
(Change jumper at only one outdoor unit when activating the transmission power supply without using a power supply unit.)
Change jumper from CN41 to CN 40 at LMAP will activate transmission power supply to LMAP itself;
Power supply unit is recommended to use for a system having more than 1 outdoor unit, because the central transmission power supply from TB7 of one of outdoor units is risking that the outdoor unit failure may let down the whole system controller system.

2-4-3-1. MA remote controller, Single-refrigerant-system, No System Controller

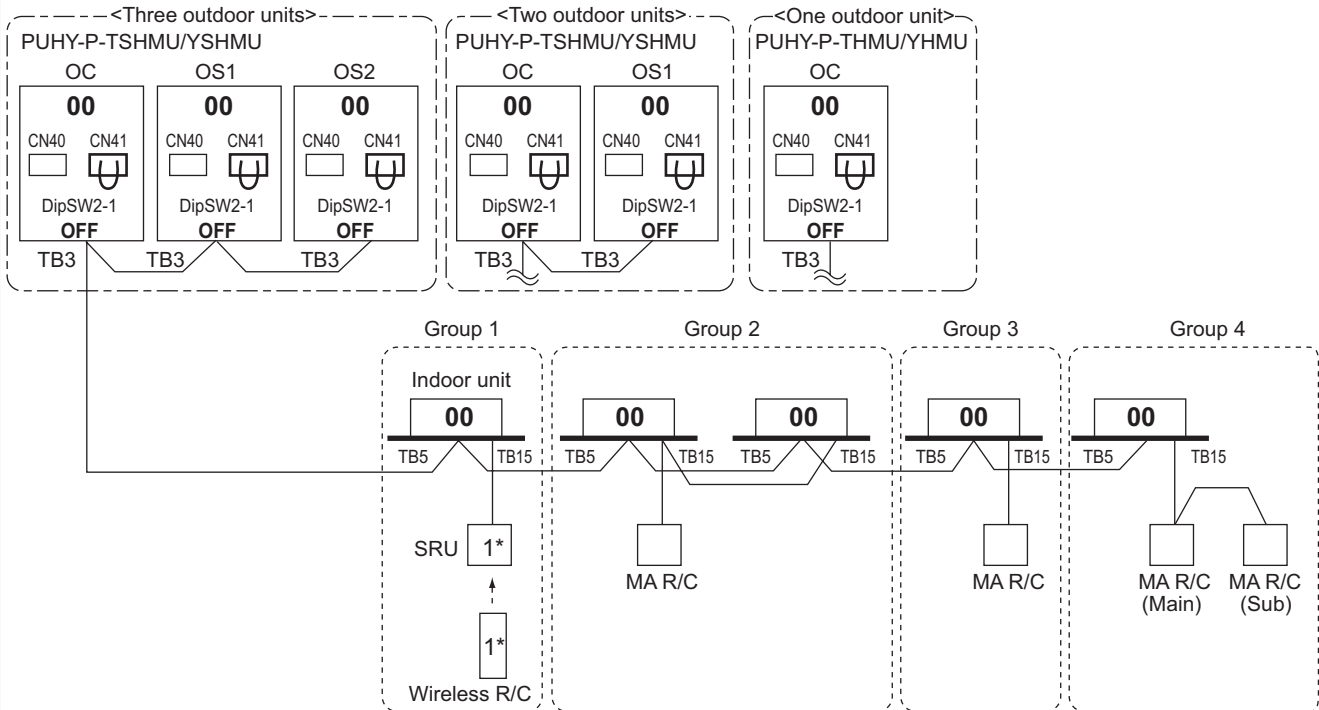

*1 For Wireless R/C and Signal receiver unit (SRU), channel 1, 2 and 3 are selectable and should be set to same channel.

NOTE:

1. Outdoor units OC, OS1 and OS2 in one refrigerant circuit system are automatically detected. OC, OS1 and OS2 are ranked in descending order of capacity. If units are the same capacity, they are ranked in ascending order of their address.
2. No address setting is needed.
3. For a system having more than 32 indoor unit (P06-P54), confirm the need of Booster at 2-3 "System configuration restrictions".

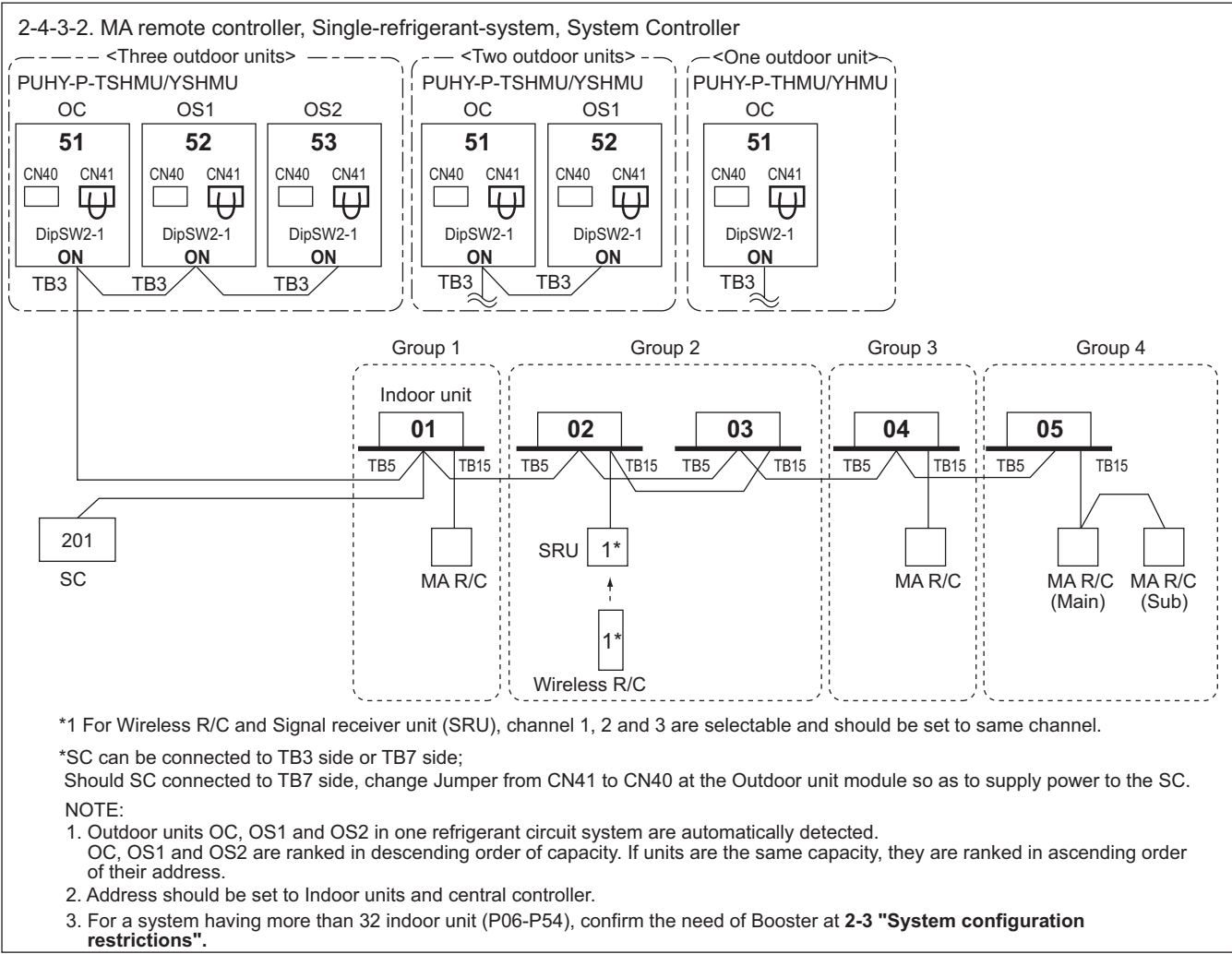

System Y

2-4-3-3. MA remote controller, Multi-refrigerant-system, System Controller at TB7/TB3 side, Booster for long M-NET wiring

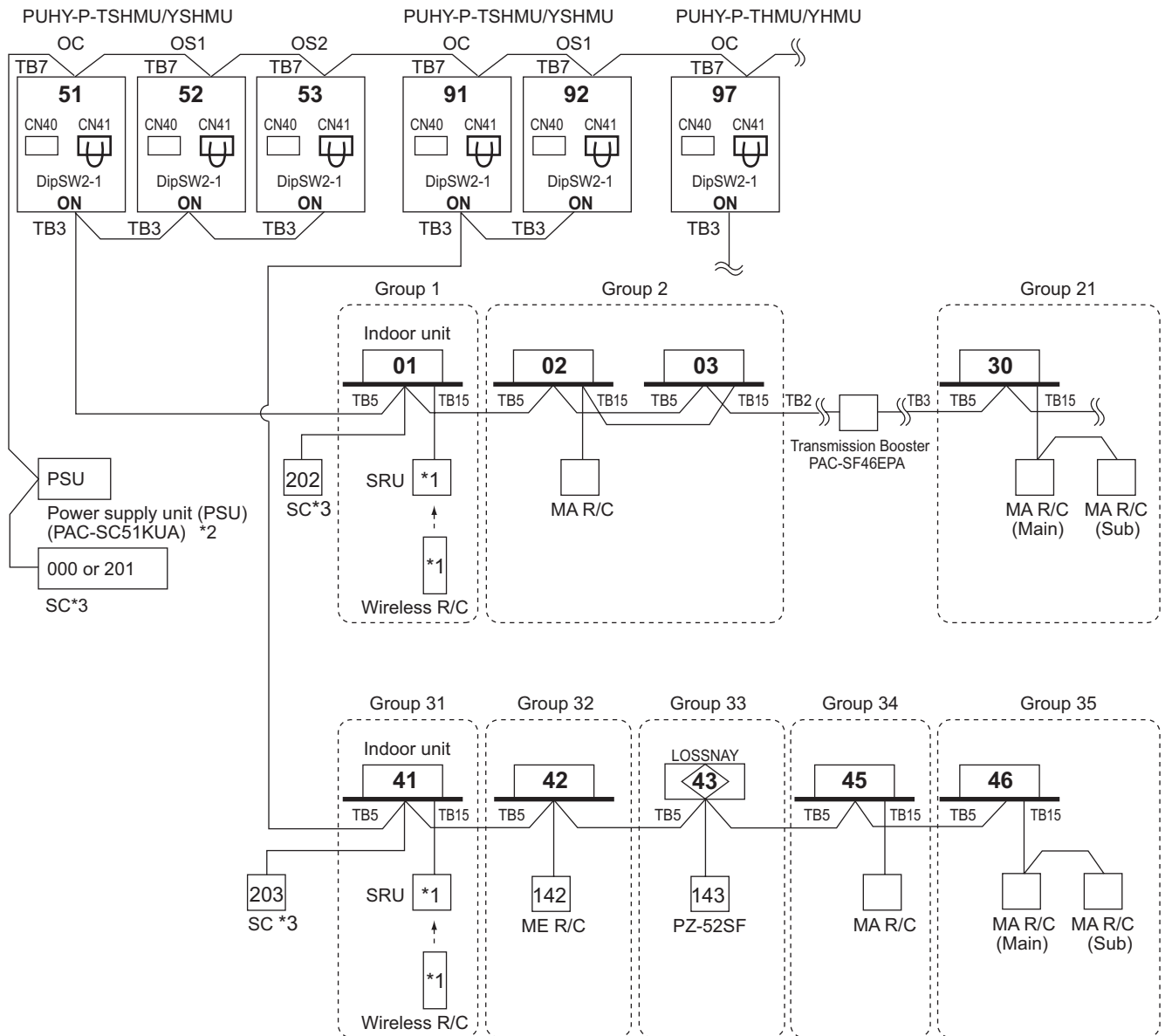

*1 For Wireless R/C and Signal receiver unit (SRU), channel 1, 2 and 3 are selectable and should be set to same channel.

*2 System controller should connect to TB7 at Outdoor and use power supply unit together in Multi-Refrigerant-System.
For G-50A, 12V DC should be used with the PAC-SC50KUA. For AG-150A, 24V DC should be used with the PAC-SC51KUA.

*3 When multiple system controllers are connected in the system, set the controller with more functions than others as a "main" controller and others as "sub".
Make the setting to only one of the system controllers for "prohibition of operation from local remote controller".

NOTE:

1. Outdoor units OC, OS1 and OS2 in one refrigerant circuit system are automatically detected.
OC, OS1 and OS2 are ranked in descending order of capacity. If units are the same capacity, they are ranked in ascending order of their address.
2. Address should be set to Indoor units, LOSSNAY and system controller.
3. M-NET power is supplied by the Outdoor unit at TB3, while Indoor unit and ME remote controller consume the M-NET power for transmission use. The power balance is needed to consider for long M-NET wiring. Details refer to 2-3 "System configuration restrictions".

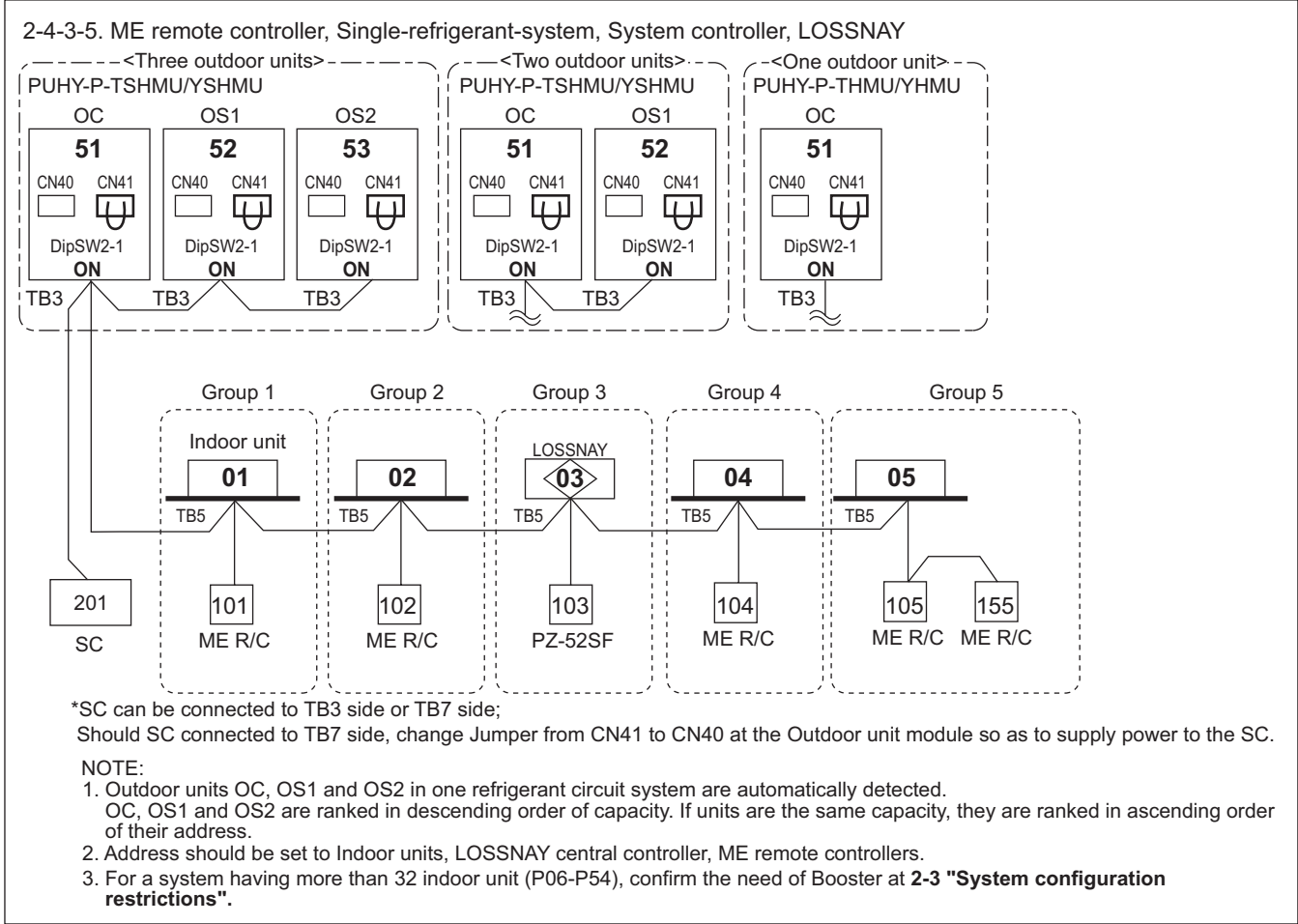
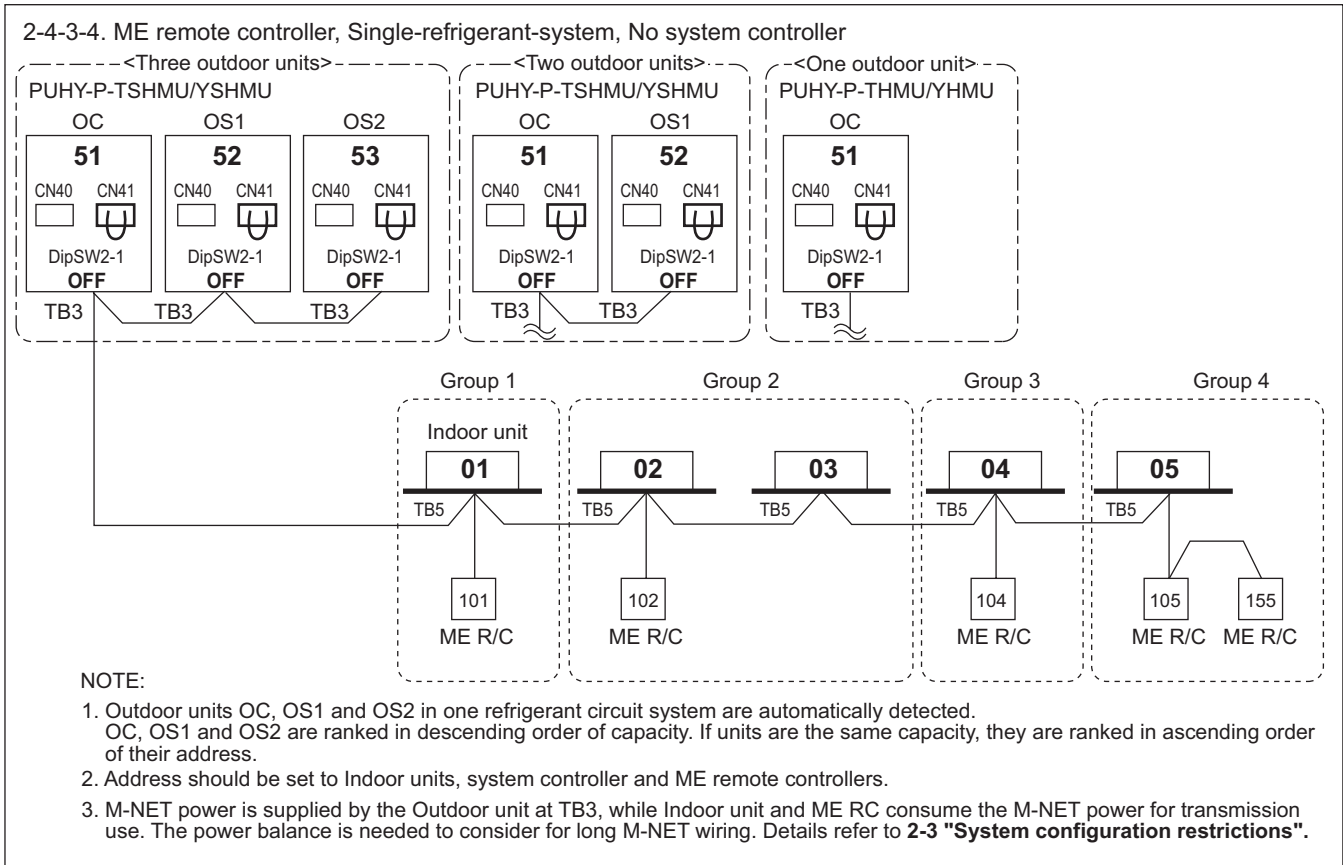

System Y

2-4-3-6. ME remote controller, Multi-refrigerant-system, System Controller at TB 7side, LOSSNAY, Booster for long M-NET wiring

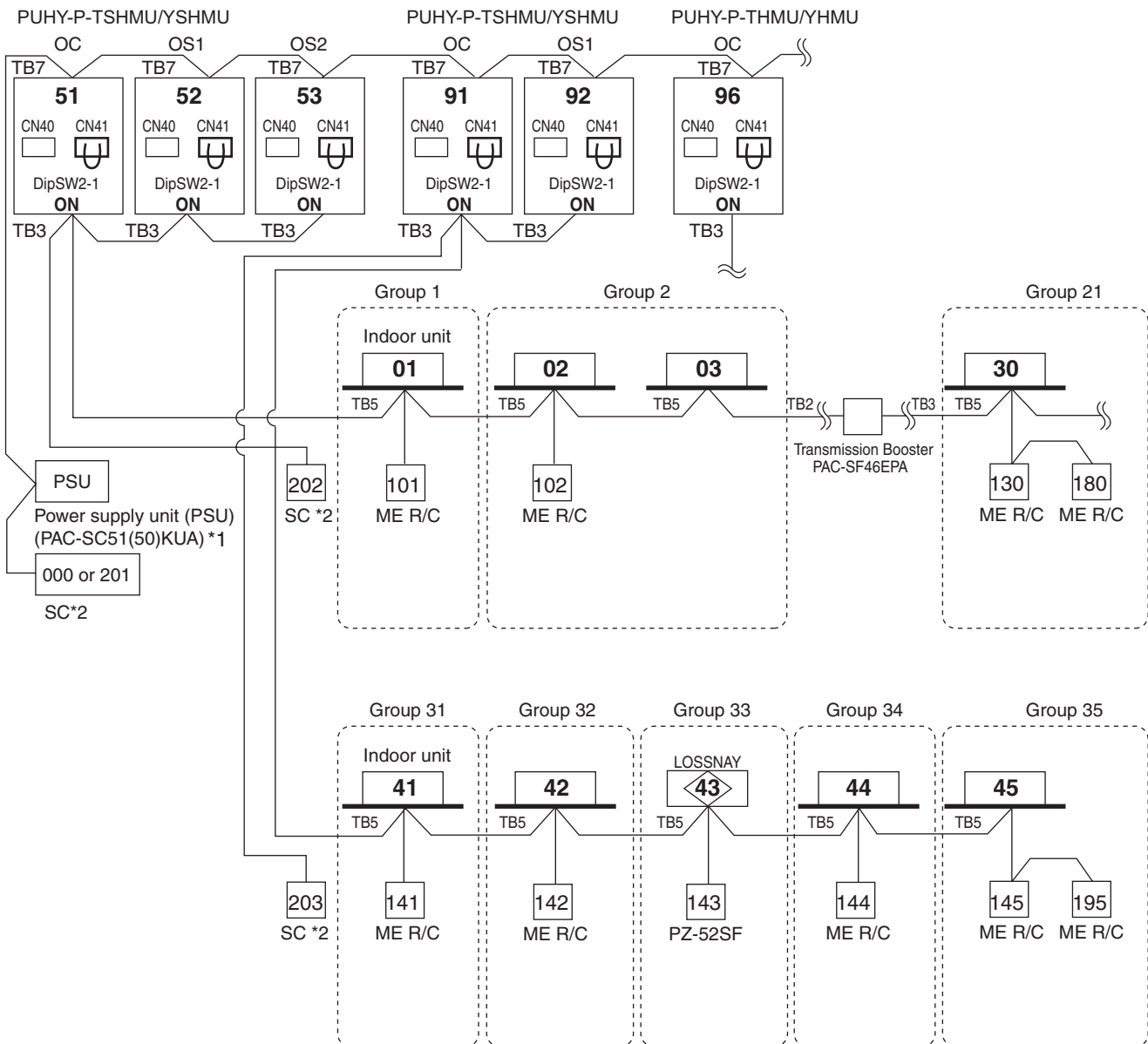

*1 System controller should connect to TB7 at Outdoor and use power supply unit together in Multi-Refrigerant-System. For G-50A, 12V DC should be used with the PAC-SC50KUA. For AG-150A, 24V DC should be used with the PAC-SC51KUA.
 *2 When multiple system controllers are connected in the system, set the controller with more functions than others as a "main" controller and others as "sub".
 Make the setting to only one of the system controllers for "prohibition of operation from local remote controller".

NOTE:

- Outdoor units OC, OS1 and OS2 in one refrigerant circuit system are automatically detected. OC, OS1 and OS2 are ranked in descending order of capacity. If units are the same capacity, they are ranked in ascending order of their address.
- M-NET power is supplied by the Outdoor unit at TB3, while Indoor unit and ME remote controller consume the M-NET power for transmission use. The power balance is needed to consider for long M-NET wiring. Details refer to 2-3 "System configuration restrictions".

2-4-3-7. TG-2000A+ AG-150A /G-50A/GB-50A

AG-150A/G-50A/GB-50A can control max. 50 indoor units;
 TG-2000A can control max. 40 pieces of AG-150A*2, G-50A or GB-50A;
 TG-2000A can control max. 2000 indoor units.

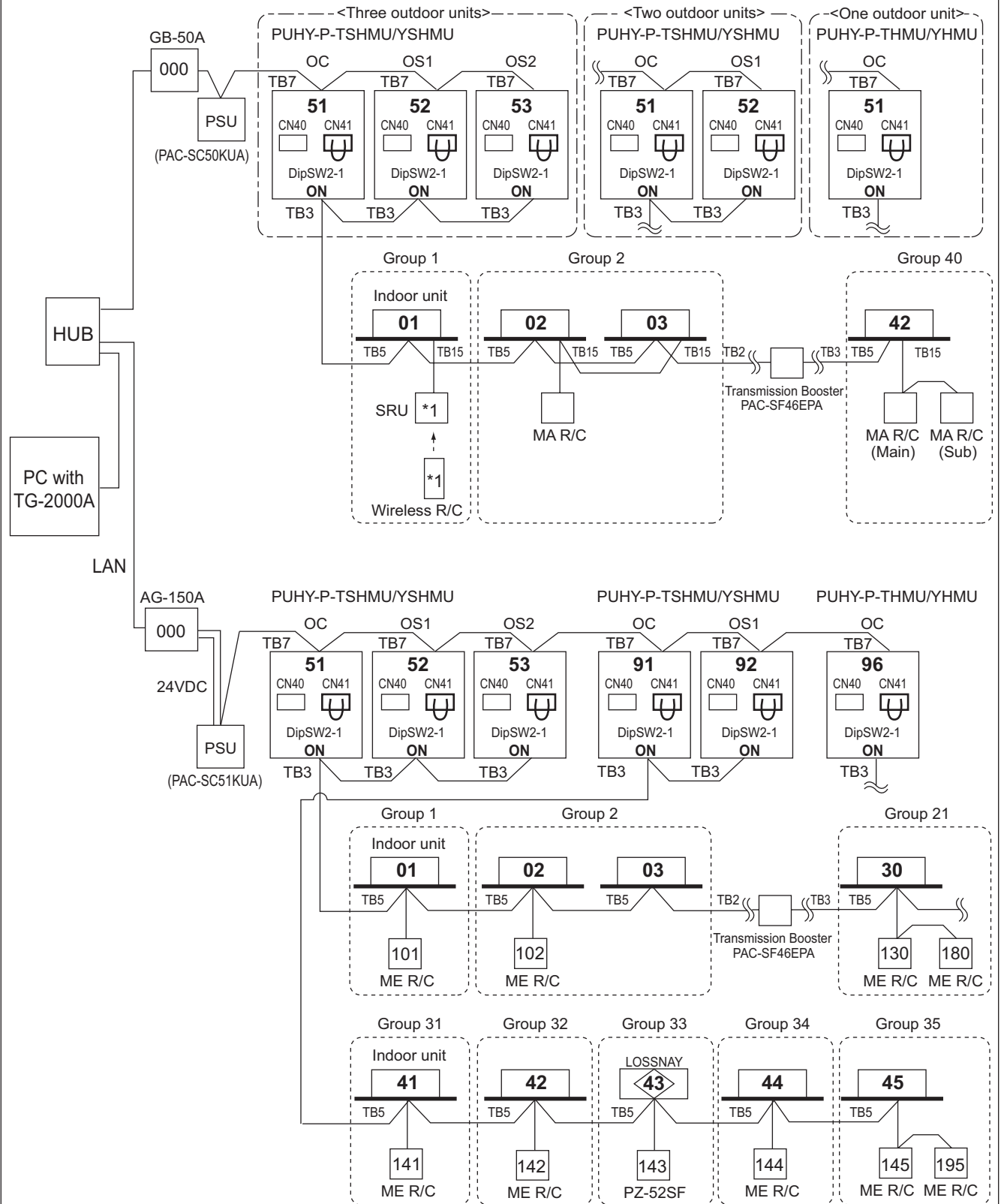

*1 For Wireless R/C and Signal receiver unit (SRU), channel 1, 2 and 3 are selectable and should be set to same channel.
 *2 Only AG-150As that are not connected to expansion controllers.

2-4-3-8. LMAP

LMAP can transmission for max. 50 indoor units;

If system controller (SC) is used, DipSW1-2 at LMAP and DipSW2-1 at Outdoor unit should set to "ON".

Change Jumper from CN41 to CN40 to activate power supply to LMAP itself for those LMAP connected without system controller (SC).

LMAP can transmission for max. 50 indoor units in single-refrigerant-system or multi-refrigerant-system.

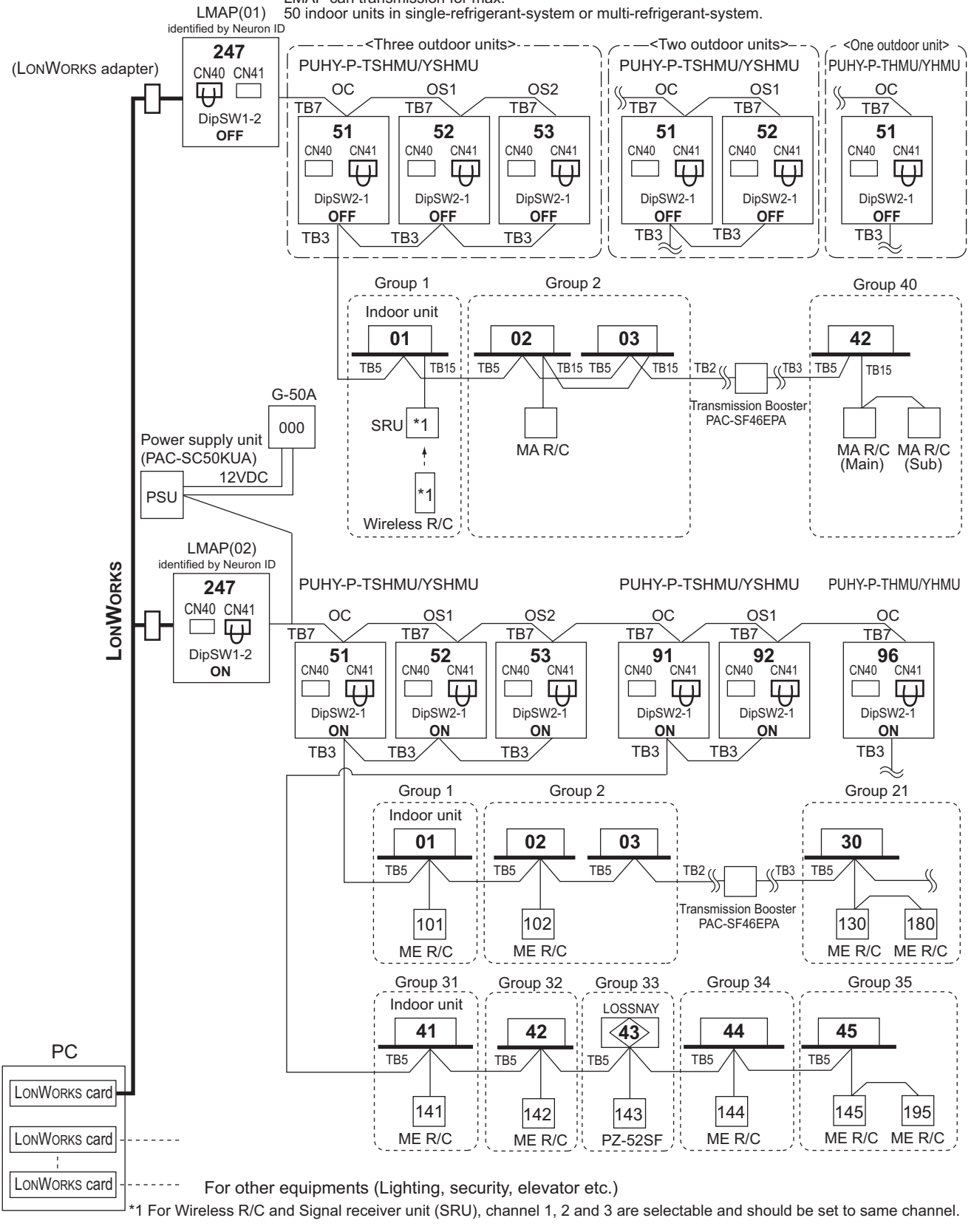

3-1. R410A Piping material

Refrigerant pipe for CITY MULTI shall be made of phosphorus deoxidized copper, and has two types.

- A. Type-O : Soft copper pipe (annealed copper pipe), can be easily bent with human's hand.
- B. Type-1/2H pipe : Hard copper pipe (Straight pipe), being stronger than Type-O pipe of the same radical thickness.

The maximum operation pressure of R410A air conditioner is 4.30 MPa [623psi]. The refrigerant piping should ensure the safety under the maximum operation pressure. MITSUBISHI ELECTRIC recommends pipe size as Table 3-1, or You shall follow the local industrial standard. Pipes of radical thickness 0.7mm or less shall not be used.

Table 3-1. Copper pipe size and radial thickness for R410A CITY MULTI.

Size (mm)	Size (inch)	Radial thickness (mm)	Radial thickness (mil)	Pipe type
ø6.35	ø1/4"	0.8	[32]	Type-O
ø9.52	ø3/8"	0.8	[32]	Type-O
ø12.7	ø1/2"	0.8	[32]	Type-O
ø15.88	ø5/8"	1.0	[40]	Type-O
ø19.05	ø3/4"	1.2	[48]	Type-O
ø19.05	ø3/4"	1.0	[40]	Type-1/2H or H
ø22.2	ø7/8"	1.0	[40]	Type-1/2H or H
ø25.4	ø1"	1.0	[40]	Type-1/2H or H
ø28.58	ø1-1/8"	1.0	[40]	Type-1/2H or H
ø31.75	ø1-1/4"	1.1	[44]	Type-1/2H or H
ø34.93	ø1-3/8"	1.2	[48]	Type-1/2H or H
ø41.28	ø1-5/8"	1.4	[56]	Type-1/2H or H

* For pipe sized ø19.05 (3/4") for R410A air conditioner, choice of pipe type is up to you.

* The figures in the radial thickness column are based on the Japanese standards and provided only as a reference. Use pipes that meet the local standards.

Flare

Due to the relative higher operation pressure of R410A compared to R22, the flare connection should follow dimensions mentioned below so as to achieve enough the air-tightness.

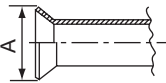
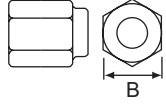
Flare pipe	Pipe size	A (For R410A) (mm[in.])	Flare nut	Pipe size	B (For R410A) (mm[in.])
	ø6.35 [1/4"]	9.1		ø6.35 [1/4"]	17.0
	ø9.52 [3/8"]	13.2		ø9.52 [3/8"]	22.0
	ø12.70 [1/2"]	16.6		ø12.70 [1/2"]	26.0
	ø15.88 [5/8"]	19.7		ø15.88 [5/8"]	29.0
	ø19.05 [3/4"]	24.0		ø19.05 [3/4"]	36.0

3-2. Piping Design

3-2-1. PUHY-P72-120THMU/YHMU Piping

System Y

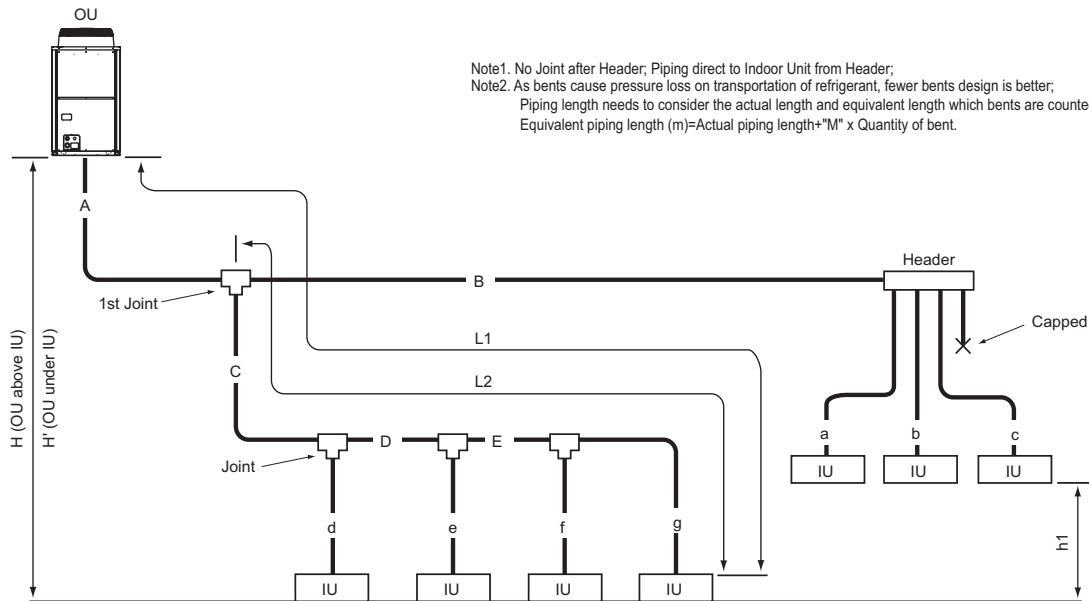

Note1. No Joint after Header; Piping direct to Indoor Unit from Header;
 Note2. As bents cause pressure loss on transportation of refrigerant, fewer bents design is better;
 Piping length needs to consider the actual length and equivalent length which bents are counted.
 Equivalent piping length (m)=Actual piping length+“M” x Quantity of bent.

Fig. 3-2-1A Piping scheme

IU : Indoor unit , OU : Outdoor unit

Table3-2-1-1. Piping length

Item	Piping in the figure	Max. length	Max. equivalent length
Total piping length	A+B+C+D+E+a+b+c+d+e+f+g	1000 [3280]	-
Farthest IU from OU (L1)	A+C+D+E+g / A+B+c	165 [541]	190 [623]
Farthest IU from first Joint (L2)	C+D+E+g / B+c	40 [131]	40 [131]
Height between OU and IU (OU above IU)	H	50 [164] *1	-
Height between OU and IU (OU under IU)	H'	40 [131] *2	-
Height between IU and IU	h1	15 [49]	-

OU: Outdoor Unit, IU: Indoor Unit
 *1 90m is available depending on the model and installation conditions. For more detailed information, contact your local distributor.
 *2 60m is available depending on the model and installation conditions. For more detailed information, contact your local distributor.

Table3-2-1-2. Bent equivalent length "M"

Outdoor Model	M (m/bends [ft./bends])
PUHY-P72T/YHMU	0.35 [1.15]
PUHY-P96T/YHMU	0.42 [1.38]
PUHY-P120T/YHMU	0.42 [1.38]

Table3-2-1-3. Piping "A" size selection rule

Outdoor and the first Joint	Pipe(Liquid)	Pipe(Gas)
PUHY-P72T/YHMU=CMY-Y102S-G2	ø9.52 [3/8]	ø19.05 [3/4]
PUHY-P96T/YHMU=CMY-Y102S/L-G2	ø9.52 [3/8] *1	ø22.20 [7/8]
PUHY-P120T/YHMU=CMY-Y102S/L-G2	ø9.52 [3/8] *2	ø22.20 [7/8]

*1.A>=90m [295ft.], ø12.70mm [1/2in.] ;
 *2.A>=40m [131ft.], ø12.70mm [1/2in.]

Table3-2-1-6. R410A Joint selection rule

Total down-stream Indoor capacity	Joint
~ P72	CMY-Y102S-G2
P73 ~ P144	CMY-Y102L-G2
P145 ~ P240	CMY-Y202-G2
P241 ~	CMY-Y302-G2

*Concerning detailed usage of Joint parts, refer to its Installation Manual.

Table3-2-1-4. Piping "B","C","D","E" size selection rule

Total down-stream Indoor capacity	Pipe(Liquid)	Pipe(Gas)
~ P54	ø9.52 [3/8]	ø15.88 [5/8]
P55 ~ P72	ø9.52 [3/8]	ø19.05 [3/4]
P73 ~ P108	ø9.52 [3/8]	ø22.20 [7/8]
P109 ~ P144	ø12.70 [1/2]	ø28.58 [1-1/8]
P145 ~ P240	ø15.88 [5/8]	ø28.58 [1-1/8]
P241 ~ P308	ø19.05 [3/4]	ø34.93 [1-3/8]
P309 ~	ø19.05 [3/4]	ø41.28 [1-5/8]

Table3-2-1-7. R410A Header selection rule

Total down-stream Indoor capacity	4-branch Header	8-branch Header	10-branch Header
	CMY-Y104-G	CMY-Y108-G	CMY-Y1010-G
	<=P72	<=P144	<=P240

* CMY-Y104-G can directly connect PUHY-P72T/YHMU, but can NOT directly connect PUHY-P96T/YHMU or above;
 * CMY-Y108-G can directly connect PUHY-P72~168T/(S)HMU, but can NOT directly connect PUHY-P192T/(S)HMU or above;
 * CMY-Y1010-G can directly connect PUHY-P72~240T/(S)HMU;
 * CMY-Y104-G can NOT connect P72~P96 Indoor, but CMY-Y108,Y1010-G can do;
 * Concerning detailed usage of Header parts, refer to its Installation Manual.

Table3-2-1-5. Piping "a","b","c","d","e","f","g" size selection rule

Indoor Unit size	Pipe(Liquid)	Pipe(Gas)
P06,P08,P12,P15,P18	ø6.35 [1/4]	ø12.70 [1/2]
P27,P30,P36,P48,P54	ø9.52 [3/8]	ø15.88 [5/8]
P72	ø9.52 [3/8]	ø19.05 [3/4]
P96	ø9.52 [3/8]	ø22.20 [7/8]

Note3. Indoor capacity is described as its model size;
 For example, PDFY-P06NMU-E, its capacity is P06;
 Note4. Total down-stream Indoor capacity is the summary of the model size of Indoors downstream.
 For example, PDFY-P06NMU-E+PDFY-P08NMU-E: Total Indoor capacity=P06+P08=P14
 Note5. Piping sized determined by the Total down-stream indoor capacity is NOT necessary to be bigger than the up-stream one.
 i.e. A>=B; A>=C>=D

3-2-2. PUHY-P144-240TSHMU/YSHMU Piping

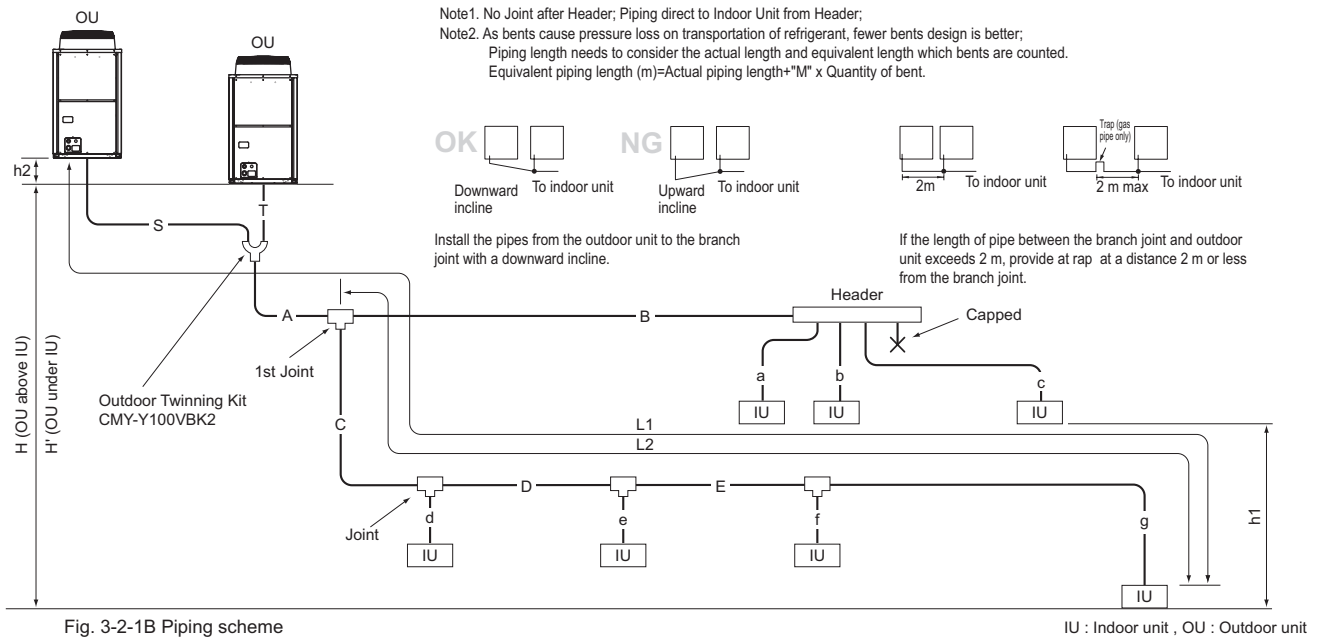

Table3-2-2-1. Piping length

Item	Piping in the figure	Max. length	Max. equivalent length
Total piping length	S+T+A+B+C+D+E+a+b+c+d+e+f+g	1000 [3280]	-
Distance between OU and OU	S+T	10[32]	-
Height between OU and OU	h2	0.1[0.3]	-
Farthest IU from OU (L1)	S(T)+A+C+D+E+g / S(T)+A+B+c	165 [541]	190 [623]
Farthest IU from the first Joint (L2)	C+D+E+g / B+c	40 [131]	40 [131]
Height between OU and IU (OU above IU)	H	50 [164] *1	-
Height between OU and IU (OU above IU)	H'	40 [131] *2	-
Height between IU and IU	h1	15 [49]	-

OU: Outdoor Unit, IU: Indoor Unit

*1 90m is available depending on the model and installation conditions. For more detailed information, contact your local distributor.

*2 60m is available depending on the model and installation conditions. For more detailed information, contact your local distributor.

Table3-2-2-2. Bends equivalent length "M"

Outdoor Model	M (m/bends [ft./bends])
PUHY-P144T/YSHMU	0.50 [1.64]
PUHY-P168T/YSHMU	0.50 [1.64]
PUHY-P192T/YSHMU	0.50 [1.64]
PUHY-P216T/YSHMU	0.50 [1.64]
PUHY-P240T/YSHMU	0.50 [1.64]

Table3-2-2-3. Piping "A" size selection rule

Outdoor and the first Joint	Pipe(Liquid)	Pipe(Gas)
CMY-Y100VBK2=CMY-Y202-G2	ø12.70[1/2]	ø28.58[1-1/8]*1
	ø15.88[5/8]	ø28.58[1-1/8]*2

*1 PUHY-P144T/YSHMU

*2 PUHY-P168-240T/YSHMU

CMY-Y100VBK2: PUHY-P144-240T/YSHMU

For Piping size "S", "T", please refer to specification of the Twining kit CMY-Y100VBK2 at the Outdoor unit's external drawing.

Table3-2-2-6. R410A Joint selection rule

Total down-stream Indoor capacity	Joint
~ P72	CMY-Y102S-G2
P73 ~ P144	CMY-Y102L-G2
P145 ~ P240	CMY-Y202-G2
P241 ~	CMY-Y302-G2

*PUHY-P192-240T/YSHMU's first Joint is always CMY-Y202-G2;

*Concerning detailed usage of Joint parts, refer to its Installation Manual.

*The total capacity of the units in the downstream of the branch joint on at least one of the piping lines that are connected to the branch joint should be 240 or below.

If the total capacity of the units in the downstream of the branch joints on both lines is 240 or above use two branch joints (CMY-Y302-G2).

Table3-2-2-4. Piping "B", "C", "D", "E" size selection rule

Total down-stream Indoor capacity	Pipe(Liquid)	Pipe(Gas)
~ P54	ø9.52 [3/8]	ø15.88 [5/8]
P55 ~ P72	ø9.52 [3/8]	ø19.05 [3/4]
P73 ~ P108	ø9.52 [3/8]	ø22.20 [7/8]
P109 ~ P144	ø12.70 [1/2]	ø28.58 [1-1/8]
P145 ~ P240	ø15.88 [5/8]	ø28.58 [1-1/8]
P241 ~ P308	ø19.05 [3/4]	ø34.93 [1-3/8]
P309 ~	ø19.05 [3/4]	ø41.28 [1-5/8]

Table3-2-2-7. R410A Header selection rule

Total down-stream Indoor capacity	4-branch Header	8-branch Header	10-branch Header
	CMY-Y104-G	CMY-Y108-G	CMY-Y1010-G
<=P72	<=P144	<=P240	

* CMY-Y104-G can directly connect PUHY-P72T/YSHMU, but can NOT directly connect PUHY-P96T/YSHMU or above;

* CMY-Y108-G can directly connect PUHY-P72-168T/Y(S)HMU, but can NOT directly connect PUHY-P192T/YSHMU or above;

* CMY-Y1010-G can directly connect PUHY-P72-240T/Y(S)HMU;

* CMY-Y104-G can NOT connect P72~P96 Indoor, but CMY-Y108, Y1010-G can do;

* Concerning detailed usage of Header parts, refer to its Installation Manual.

Note3. Indoor capacity is described as its model size;
 For example, PDFY-P06NMU-E, its capacity is P06;

Note4. Total down-stream Indoor capacity is the summary of the model size of Indoors downstream.

For example, PDFY-P06NMU-E+PDFY-P08NMU-E: Total Indoor capacity=P06+P08=P14

Note5. Piping sized determined by the Total down-stream indoor capacity is NOT necessary

to be bigger than the up-stream one.

i.e. A>=B, A>=C>=D

Table3-2-2-5. Piping "a", "b", "c", "d", "e", "f", "g" size selection rule

Indoor Unit size	Pipe(Liquid)	Pipe(Gas)
P06,P08,P12,P15,P18	ø6.35 [1/4]	ø12.70 [1/2]
P27,P30,P36,P48,P54	ø9.52 [3/8]	ø15.88 [5/8]
P72	ø9.52 [3/8]	ø19.05 [3/4]
P96	ø9.52 [3/8]	ø22.20 [7/8]

3-2-3. PUHY-P264-360TSHMU/YSHMU Piping

System Y

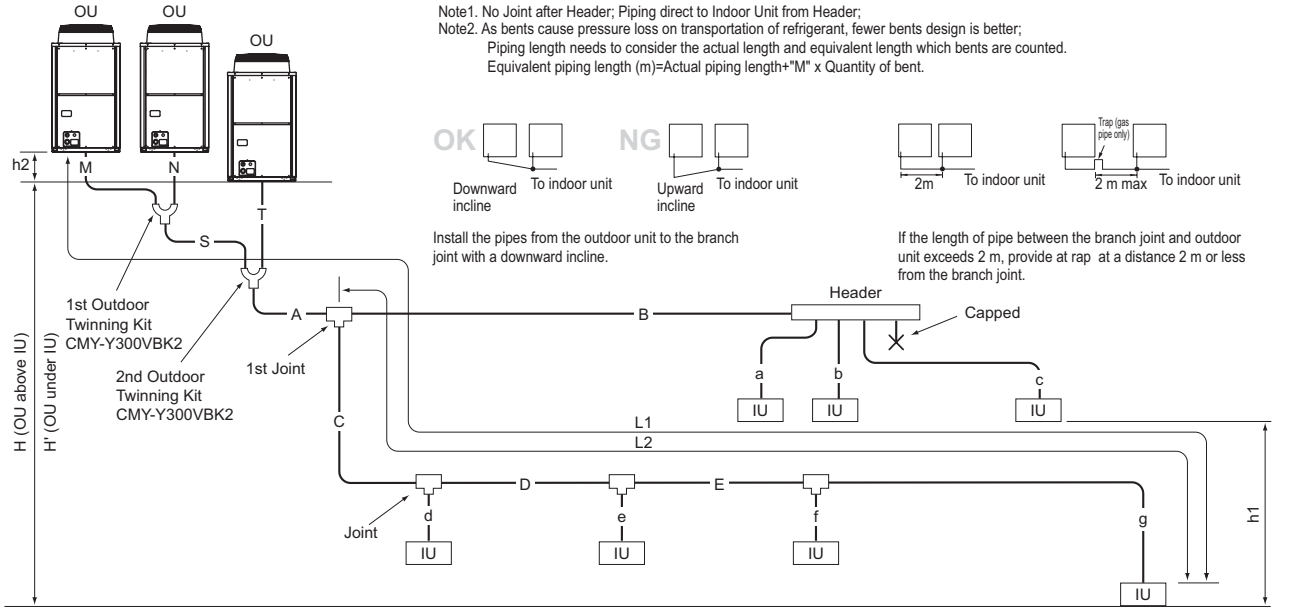

Fig. 3-2-1C Piping scheme

IU : Indoor unit , OU : Outdoor unit

Table3-2-3-1. Piping length

Item	Piping in the figure	Max. length	Max. equivalent length
Total piping length	S+T+M+N+A+B+C+D+E+a+b+c+d+e+f+g	1000[3280]	-
Distance between OU and OU	M+N+S+T	10[32]	-
Height between OU and OU	h2	0.1[0.3]	-
Farthest IU from OU (L1)	M(N)+S+A+C+D+E+g / M(N)+S+A+B+c	165[541]	190[623]
Farthest IU from the first Joint (L2)	C+D+E+g / B+c	40[131]	40[131]
Height between OU and IU (OU above IU)	H	50[164] *1	-
Height between OU and IU (OU above IU)	H'	40[131] *2	-
Height between IU and IU	h1	15[49]	-

Table3-2-3-2. Bends equivalent length "M"

Outdoor Model	M (m/bends [ft./bends])
PUHY-P264T/YSHMU	0.70 [2.29]
PUHY-P288T/YSHMU	0.70 [2.29]
PUHY-P312T/YSHMU	0.70 [2.29]
PUHY-P336T/YSHMU	0.80 [2.62]
PUHY-P360T/YSHMU	0.80 [2.62]

OU: Outdoor Unit, IU: Indoor Unit
 *1 90m is available depending on the model and installation conditions. For more detailed information, contact your local distributor.
 *2 60m is available depending on the model and installation conditions. For more detailed information, contact your local distributor.

Table3-2-3-3. Piping "A" size selection rule

Outdoor and the first Joint	Pipe(Liquid)	Pipe(Gas)
CMY-Y300VBK2=CMY-Y302-G2	ø19.05[3/4]	ø34.93[1-3/8] *1
	ø19.05[3/4]	ø41.28[1-5/8] *2

*1 PUHY-P264-312TSHMU/YSHMU
 *2 PUHY-P336,360TSHMU/YSHMU
 CMY-Y300VBK2;PUHY-P264-360T/YSHMU

For Piping size "M", "N", "S", "T", please refer to specification of the Twining kit CMY-Y300VBK2 at the Outdoor unit's external drawing.

Table3-2-3-6. R410A Joint selection rule

Total down-stream Indoor capacity	Joint
~ P72	CMY-Y102S-G2
P73 ~ P144	CMY-Y102L-G2
P145 ~ P240	CMY-Y202-G2
P241 ~	CMY-Y302-G2

*The total capacity of the units in the downstream of the branch joint on at least one of the piping lines that are connected to the branch joint should be 240 or below.
 If the total capacity of the units in the downstream of the branch joints on both lines is 240 or above use two branch joints (CMY-Y302-G2).
 *Concerning detailed usage of Joint parts, refer to its Installation Manual.

Table3-2-3-4. Piping "B", "C", "D", "E" size selection rule

Total down-stream Indoor capacity	Pipe(Liquid)	Pipe(Gas)
~ P54	ø9.52 [3/8]	ø15.88 [5/8]
P55 ~ P72	ø9.52 [3/8]	ø19.05 [3/4]
P73 ~ P108	ø9.52 [3/8]	ø22.20 [7/8]
P109 ~ P144	ø12.70 [1/2]	ø28.58 [1-1/8]
P145 ~ P240	ø15.88 [5/8]	ø28.58 [1-1/8]
P241 ~ P308	ø19.05 [3/4]	ø34.93 [1-3/8]
P309 ~	ø19.05 [3/4]	ø41.28 [1-5/8]

Table3-2-3-7. R410A Header selection rule

Total down-stream Indoor capacity	4-branch Header	8-branch Header	10-branch Header
	CMY-Y104-G	CMY-Y108-G	CMY-Y1010-G
	<=P200	<=P400	<=P650

* CMY-Y104-G can directly connect PUHY-P72T/YHMMU, but can NOT directly connect PUHY-P96T/YHMMU or above;
 * CMY-Y108-G can directly connect PUHY-P72-168T(Y(S))HMMU, but can NOT directly connect PUHY-P192T/YSHMU or above;
 * CMY-Y1010-G can directly connect PUHY-P72-240T(Y(S))HMMU;
 * CMY-Y104-G can NOT connect P72-P96 Indoor, but CMY-Y108, Y1010-G can do;
 * Concerning detailed usage of Header parts, refer to its Installation Manual.

Table3-2-3-5. Piping "a", "b", "c", "d", "e", "f", "g" size selection rule

Indoor Unit size	Pipe(Liquid)	Pipe(Gas)
P06,P08,P12,P15,P18	ø6.35 [1/4]	ø12.70 [1/2]
P27,P30,P36,P48,P54	ø9.52 [3/8]	ø15.88 [5/8]
P72	ø9.52 [3/8]	ø19.05 [3/4]
P96	ø9.52 [3/8]	ø22.20 [7/8]

Note3. Indoor capacity is described as its model size;
 For example, PDFY-P06NMU-E, its capacity is P06;
 Note4. Total down-stream Indoor capacity is the summary of the model size of Indoors downstream.
 For example, PDFY-P06NMU-E+PDFY-P08NMU-E: Total Indoor capacity=P06+P08=P14
 Note5. Piping sized determined by the Total down-stream indoor capacity is NOT necessary to be bigger than the up-stream one.
 i.e. A>=B; A>=C>=D

3-3. Refrigerant charging calculation

At the time of shipping, the outdoor unit is charged with the refrigerant. As this charge does not include the amount needed for extended piping, additional charging for each refrigerant line will be required on site. In order that future servicing may be properly provided, always keep a record of the size and length of each refrigerant line and the amount of additional charge by writing it in the space provided on the outdoor unit.

(1) Calculation of additional refrigerant charge

- Calculate the amount of additional charge based on the length of the piping extension and the size of the refrigerant line.
- Use the table to the below as a guide to calculating the amount of additional charging and charge the system accordingly.
- If the calculation results in a fraction of less than 0.1kg[1oz], round up to the next 0.1kg[1oz]. For example, if the result of the calculation was 12.38kg[435.1oz], round the result up to 12.4kg[436oz].

<Additional Charge>

Additional refrigerant charge	=	Total length of liquid pipe sized ø19.05 [3/4"]	+	Total length of liquid pipe sized ø15.88 [5/8"]	+	Total length of liquid pipe sized ø12.7 [1/2"]	+	Total length of liquid pipe sized ø9.52 [3/8"]	+	Total length of liquid pipe sized ø6.35 [1/4"]	+ α
(kg) (oz)		(m) x 0.29 (kg/m) (ft.) x 3.1 [oz/ft.]		(m) x 0.20 (kg/m) (ft.) x 2.15 [oz/ft.]		(m) x 0.12 (kg/m) (ft.) x 1.29 [oz/ft.]		(m) x 0.06 (kg/m) (ft.) x 0.65 [oz/ft.]		(m) x 0.024 (kg/m) (ft.) x 0.26 [oz/ft.]	

Table3-2-4-1. Value of α

Total capacity of connecting indoor units	α	
Models ~ 27	2.0 kg	[71 oz]
Models 28 ~ 54	2.5 kg	[89 oz]
Models 55 ~ 126	3.0 kg	[106 oz]
Models 127 ~ 144	3.5 kg	[124 oz]
Models 145 ~ 180	4.5 kg	[160 oz]
Models 181 ~ 234	5.0 kg	[177 oz]
Models 235 ~ 273	6.0 kg	[212 oz]
Models 274 ~ 307	8.0 kg	[283 oz]
Models 308 ~ 342	9.0 kg	[318 oz]
Models 343 ~ 411	10.0 kg	[353 oz]
Models 412 ~ 480	12.0 kg	[424 oz]
Models 481 ~	14.0 kg	[494 oz]

Example: PUHY-P120THMU/YHMU

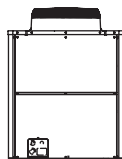

m [kg]		ft. [oz]	
Indoor 1: P48	A: ø12.7 40 m	a: ø9.52 10 m	Indoor 1: P48 A: ø1/2" 131ft.
2: P36	B: ø9.52 10 m	b: ø9.52 5 m	2: P36 B: ø3/8" 32ft.
3: P15	C: ø9.52 15 m	c: ø6.35 10 m	3: P15 C: ø3/8" 49ft.
4: P12	D: ø9.52 10 m	d: ø6.35 10 m	4: P12 D: ø3/8" 32ft.
5: P24	e: ø9.52 10 m	e: ø9.52 10 m	5: P24 e: ø3/8" 32ft.

The total length of liquid pipe of each size is as follows:
 ø12.7 : A= 40 = 40 m
 ø9.52 : B + C + D + a + b + e = 10 + 15 + 10 + 10 + 5 + 10 = 60 m
 ø6.35 : c + d = 10 + 10 = 20 m

Total capacity of connecting Indoor units Pt :
 Pt = P48 + P36 + P15 + P12 + P24 = P135, therefore $\alpha = 3.5\text{kg}$

The total length of liquid pipe of each line is as follows:
 ø1/2" : A= 131 = 131ft.
 ø3/8" : B + C + D + a + b + e = 32 + 49 + 32 + 32 + 16 + 32 = 193ft.
 ø1/4" : c + d = 32 + 32 = 64ft.

Total capacity of connecting Indoor units Pt :
 Pt = P48 + P36 + P15 + P12 + P24 = P135, therefore $\alpha = 124\text{oz}$

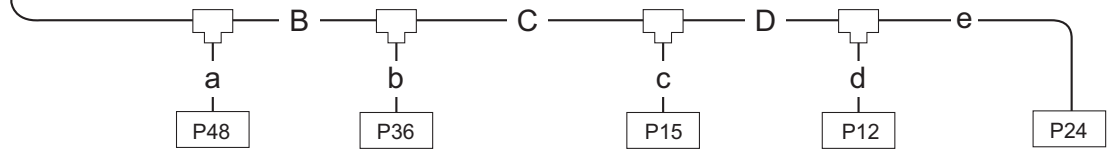

Additional refrigerant charge	=	Total length of liquid pipe sized ø19.05	+	Total length of liquid pipe sized ø15.88	+	Total length of liquid pipe sized ø12.7	+	Total length of liquid pipe sized ø9.52	+	Total length of liquid pipe sized ø6.35	+ 3.5
(kg)		x 0.29 (kg/m)		x 0.20 (kg/m)		x 0.12 (kg/m)		x 0.06 (kg/m)		x 0.024 (kg/m)	
		0 (m) x 0.29 (kg/m)		0 (m) x 0.20 (kg/m)		40 (m) x 0.12 (kg/m)		60 (m) x 0.06 (kg/m)		20 (m) x 0.024 (kg/m)	
		= 0		+ 0		+ 40 x 0.12		+ 60 x 0.06		+ 20 x 0.024	+ 3.5
		= 12.4 kg									

or

Additional refrigerant charge	=	Total length of liquid pipe sized ø3/4"	+	Total length of liquid pipe sized ø5/8"	+	Total length of liquid pipe sized ø1/2"	+	Total length of liquid pipe sized ø3/8"	+	Total length of liquid pipe sized ø1/4"	+ 124
(oz)		x 3.1 (oz/ft.)		x 2.15 (oz/ft.)		x 1.29 (oz/ft.)		x 0.65 (oz/ft.)		x 0.26 (oz/ft.)	
		0 (ft.) x 3.1 (oz/ft.)		0 (ft.) x 2.15 (oz/ft.)		131 (ft.) x 1.29 (oz/ft.)		193 (ft.) x 0.65 (oz/ft.)		64 (ft.) x 0.26 (oz/ft.)	
		= 0		+ 0		+ 131 x 1.29		+ 193 x 0.65		+ 64 x 0.26	+ 124
		= 436 [oz]									

4-1. Requirement on installation site

1. No direct thermal radiation to the unit.
2. No possibility of annoying the neighbors by the sound of the unit.
3. Avoid the sites where strong winds blow.
4. With strength to bear the weight of the unit.
5. Drain flow from the unit is cared at heating mode.
6. Enough space for installation and service as shown at 4-2.
7. Avoid the sites where acidic solutions or chemical sprays (sulfur series) are used frequently.
8. The unit should be secure from combustible gas, oil, steam, chemical gas like acidic solution, sulfur gas and so on.

4-2. Spacing

In case of single installation

- Secure enough space around the unit as shown in the figure.

<A> : Top view

Ⓐ : Front

Ⓒ : Back

 : Side view

Ⓑ : Unit height

Ⓓ : Air outlet guide (Procured at the site)

<C> : When there is little space up to an obstruction

(1) If the distance is 300 mm [11-13/16 in.] or more between the rear side and the wall

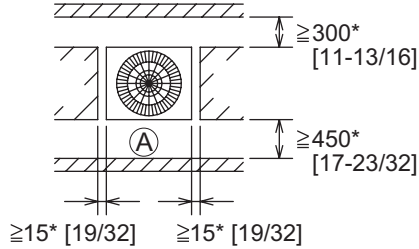

<A>

(2) If the distance is 100 mm [3-15/16 in.] or more between the rear side and the wall

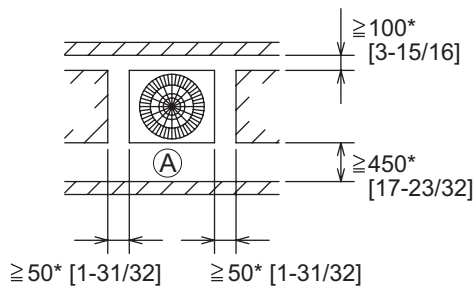

<A>

(3) If the wall height (H) of the front, rear or side exceeds the wall height restriction

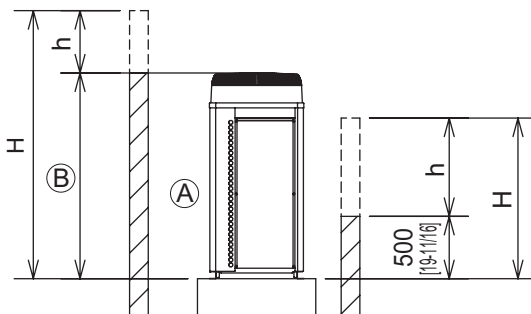

- When the height of the walls on the front, back or on the sides <H> exceeds the wall height limit as defined below, add the height that exceeds the height limit <h> to the figures that are marked with an asterisk.

<Wall height limit> Front: Up to the unit height

Back: Up to 500mm [19-11/16 in.] from the unit bottom

Side: Up to the unit height

(4) If there are obstacles at the upper part of the unit

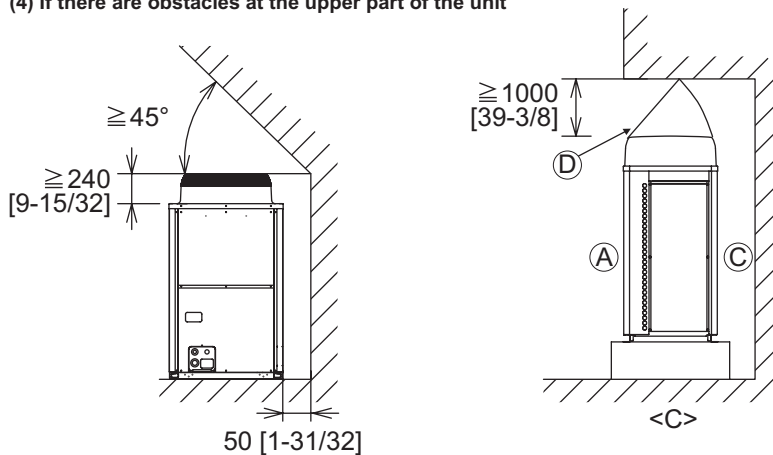

(Unit : mm [in.])

In case of collective installation and continuous installation

- Ⓐ : Front Ⓒ : Wall height (H)
- Ⓑ : Must be open

- When multiple units are installed adjacent to each other, secure enough space to allow for air circulation and passageways between groups of units as shown in the figures.
- At least two sides must be left open.
- As with the single installation, add the height that exceeds the height limit <h> to the figures that are marked with an asterisk.

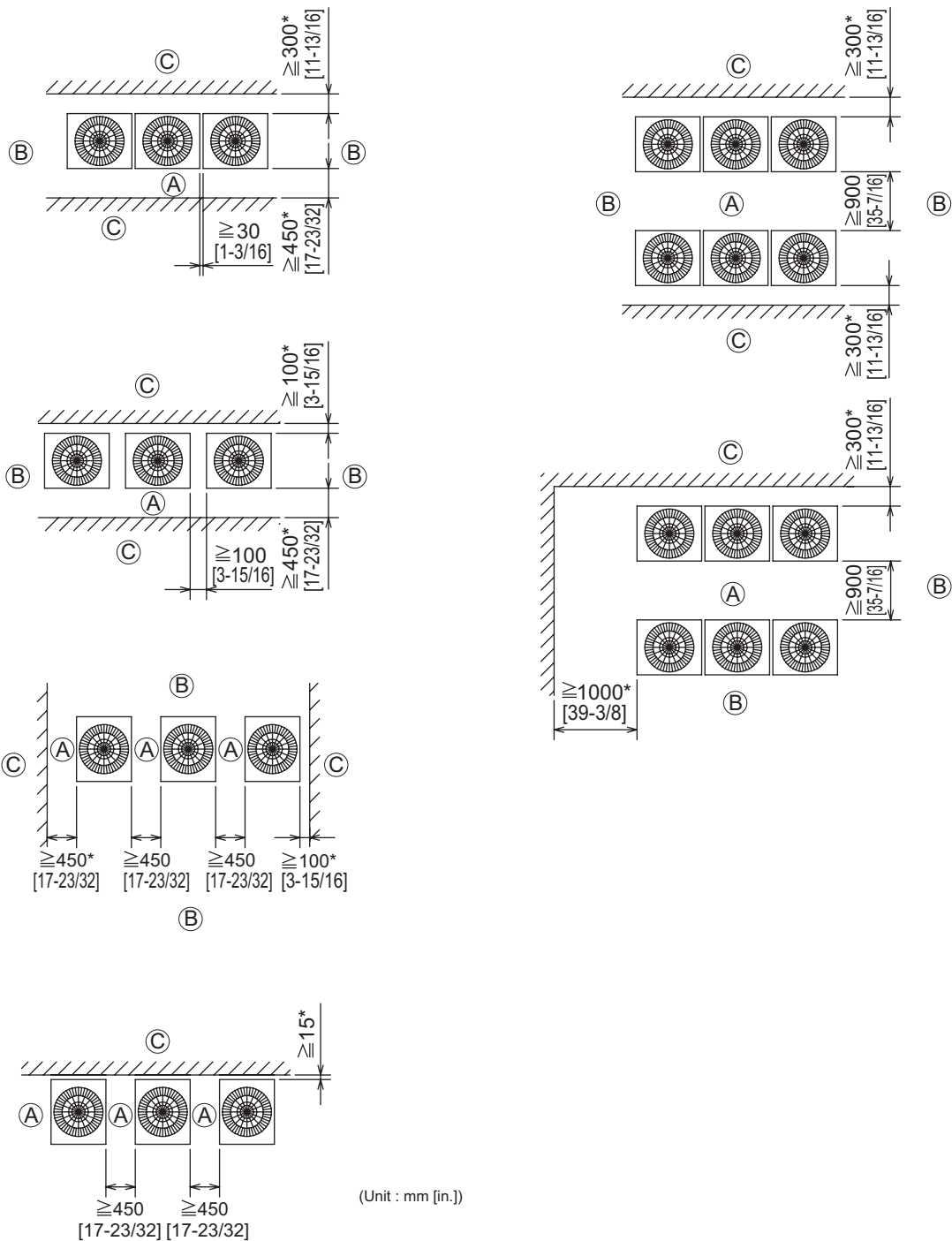

4-3. Piping direction

4-3-1. Lifting method

- When lifting the unit with ropes, run the ropes under the unit and use the lifting hole.
- Support the unit at four points with two ropes, and avoid giving mechanical shock.
- Suspension rope angle must be 40° or less, so as to avoid compressing fan guard.
- Use two ropes, each at least 8m [26 ft.] in length
- Use ropes strong enough to support the weight of the unit.
- Always suspend the unit from four corners. (It is dangerous to suspend a unit from two corners and must not be attempted.)
- Use protective pads to keep the ropes from scratching the panels on the unit.

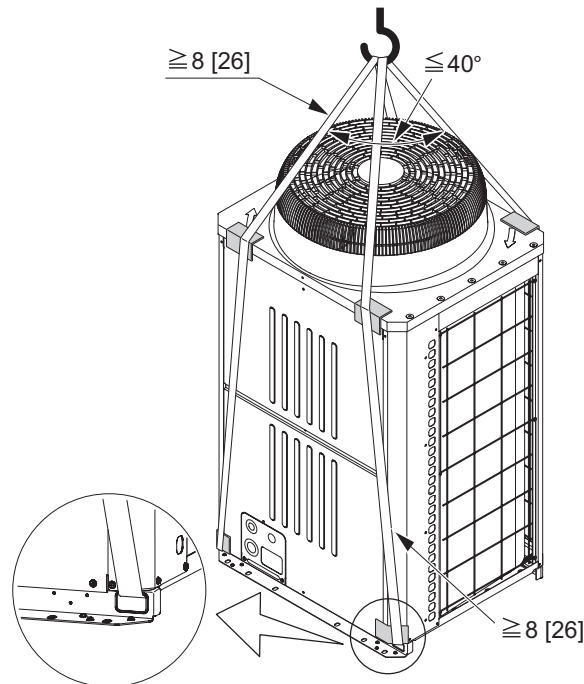

CAUTION

Exercise caution when transporting products.

- Products weighing more than 20 kg [45 LBS] should not be carried alone.
- Do not carry the product by the PP bands.
- To avoid the risk of injury, do not touch the heat exchanger fins.
- Plastic bags may pose a risk of choking hazard to children. Tear plastic bags into pieces before disposing of them.
- When lifting and transporting outdoor units with ropes, run the ropes through lifting hole at the unit base. Securely fix the unit so that the ropes will not slide off, and always lift the unit at four points to prevent the unit from falling.

4-3-2. Installation

System Y

- Secure the unit with anchor bolts as shown in the figure below so that the unit will not topple over with strong wind or during an earthquake.
- Install the unit on a durable base made of such materials as concrete or angle steel.
- Take appropriate anti-vibration measures (e.g., vibration damper pad, vibration isolation base) to keep vibrations and noise from being transmitted from the unit through walls and floors.
- When using a rubber cushion, install it so that the cushion covers the entire width of the unit leg.
- Install the unit in such a way that the corner of the angle bracket at the base of the unit shown in the figure below is securely supported.
- Install the anchor bolt in such a way that the top end of the anchor bolt do not stick out more than 30 mm [1-3/16 in.].
- This unit is not designed to be anchored with post-installation-type anchor bolts, although by adding fixing brackets anchoring with such type of anchor bolts becomes possible.

- (A): M10 anchor bolt procured at the site.
 - (B): Corner is not seated.
 - (C): Fixing bracket for hole-in anchor bolt (3 locations to fix with screws).
 - (D): Detachable leg
- <Without detachable leg>

WARNING
 Properly install the unit on a surface that can withstand the weight of the unit. Unit installed on an unstable surface may fall and cause injury.

WARNING
 Take appropriate safety measures against strong winds and earthquakes to prevent the unit from falling.

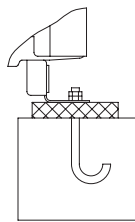
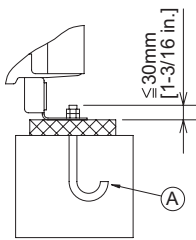

Install the unit in such a way that the corner of the angle bracket at the base of the unit shown in the figure is securely supported. The brackets may bend if they are not securely supported.

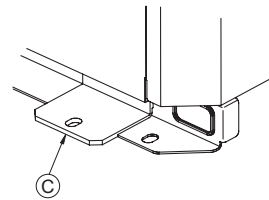
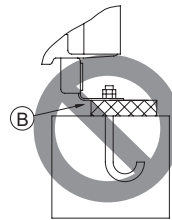

Take into consideration the durability of the base, water drainage route (Drain water is discharged from outdoor units during operation.), piping route, and wiring route when performing foundation work.

4-3-3. Anchor bolt positions

• Individual installation

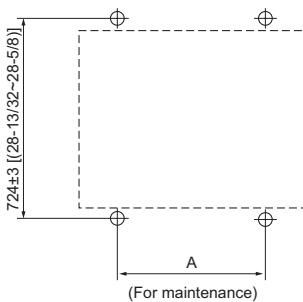

• Collective installation

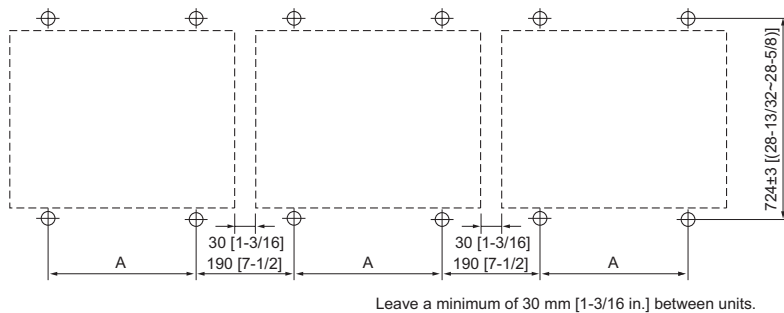

PUHY	P72, P96	P120
A	760±2 [29-15/16(29-27/32~30)]	1060±2 [41-3/4(41-21/32~41-13/16)]

4-3-4. Installation

When the pipes and/or cables are routed at the bottom of the unit, make sure that the through hole at the base of the unit does not get blocked with the installation base.
When the pipes are routed at the bottom of the unit, the base should be at least 100 mm [3-15/16 in.] in height.

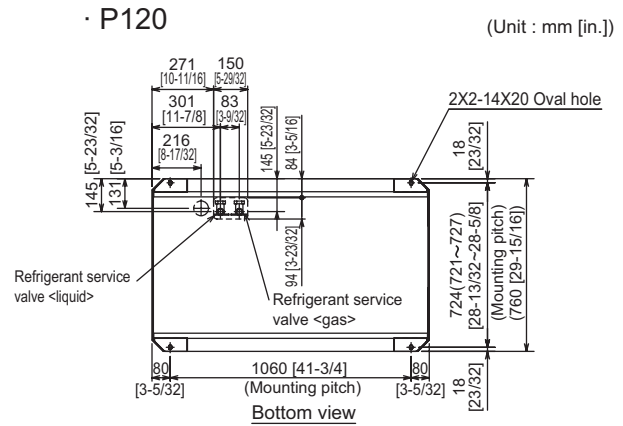
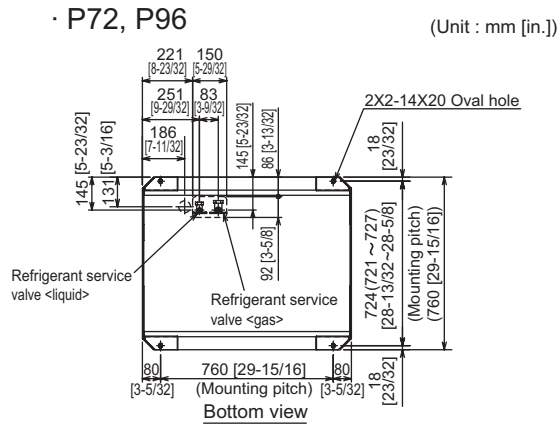

Installation base parallel to the unit's front panel

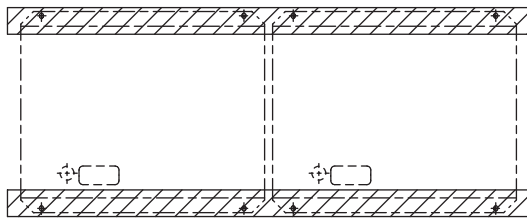

Installation base perpendicular to the unit's front panel

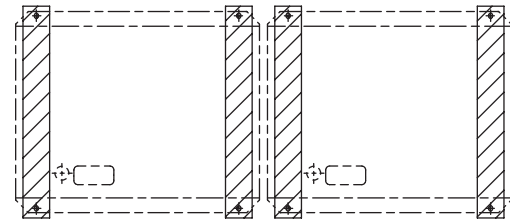

4-3-5. Refrigerant pipe routing

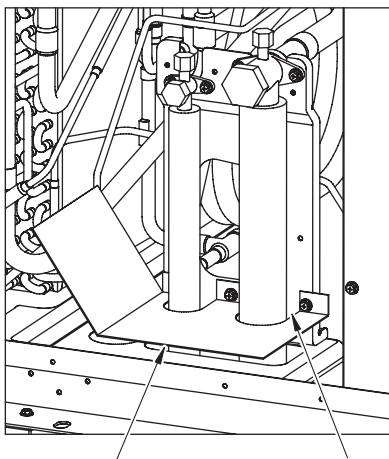

Example of closure materials (field supply) Fill the gap at the site

The gaps around the edges of through holes for pipes and wires on the unit allow water or mice to enter the unit and damage its parts. Close these gaps with filler plates.

This unit allows two types of pipe routing:

- Bottom piping
- Front piping

⚠ CAUTION

To prevent small animals, water and snow from entering the unit and damage its parts, close the gap around the edges of through holes for pipes and wires with filler plates.

4-3-6. Twinning on the outdoor unit side

- The tilt angle of the twinning pipe
The tilt angle of the twinning pipe must be within $\pm 15^\circ$ with the horizontal plane.
Tilting the twinning pipe more than specified will cause damage to the unit.
- The length of the straight part of the pipe before the branching
For the twinning kit, always use the accessory piping parts.
The length of the straight part of pipe connected in front of the twinning pipe must be 500 mm [19 in.] or longer.
(Connect the field piping so that the length of the straight part of pipe connected in front of the twinning pipe can be 500 mm [19 in.] or longer.)
If the length is less than 500 mm [19 in.], it will cause damage to the unit.
- The piping connection
 - When connecting the twinning kit to the outdoor unit, note the following:
If the length of piping from the twinning kit to the outdoor unit is more than 2 m [6 ft.], install a trap within 2 m [6 ft.] from the outdoor unit. The height of the trap must be 200 mm [7 in.] or higher.
 - Make sure the pipes from the twinning pipe to the outdoor unit are sloped downwards (towards the twinning pipes).

Note: See the following drawing for the fitting position of the twinning pipe.

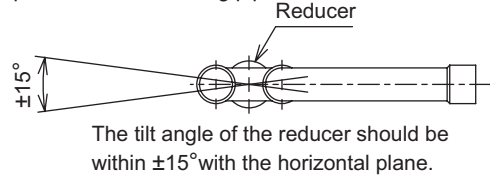

<2 m [6 ft.] or less>

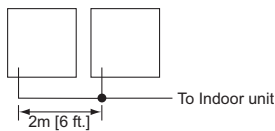

<More than 2 m [6 ft.]>

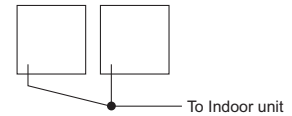
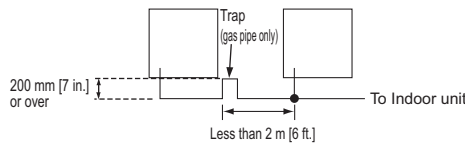

When installing the twinning kit in a higher position than the outdoor unit base, make sure that the twinning kit is installed in a position lower than 200 mm [7 in.] from the outdoor unit base.

<PUHY-P144TSHMU/YSHMU>

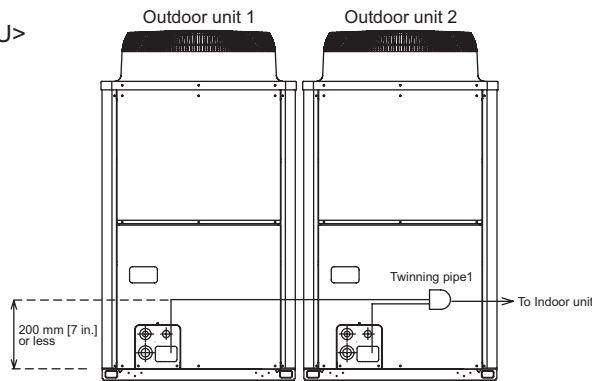

<PUHY-P264TSHMU/YSHMU>

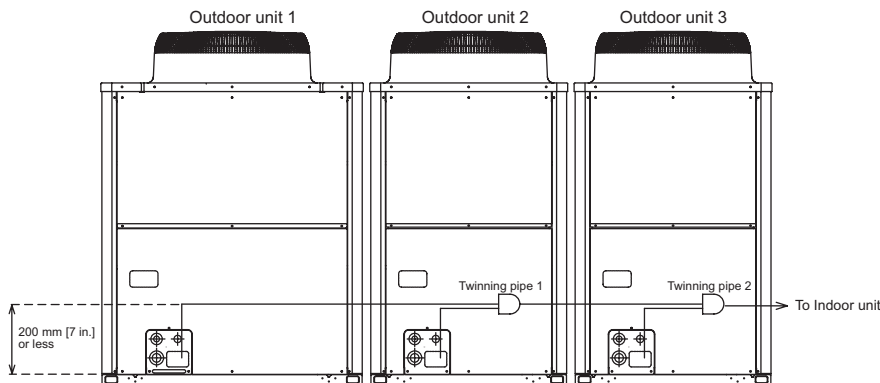

4-3-7. Twinning on the outdoor unit side

See the following drawing for connecting the pipes between the outdoor units.

<PUHY-P144TSHMU/YSHMU>

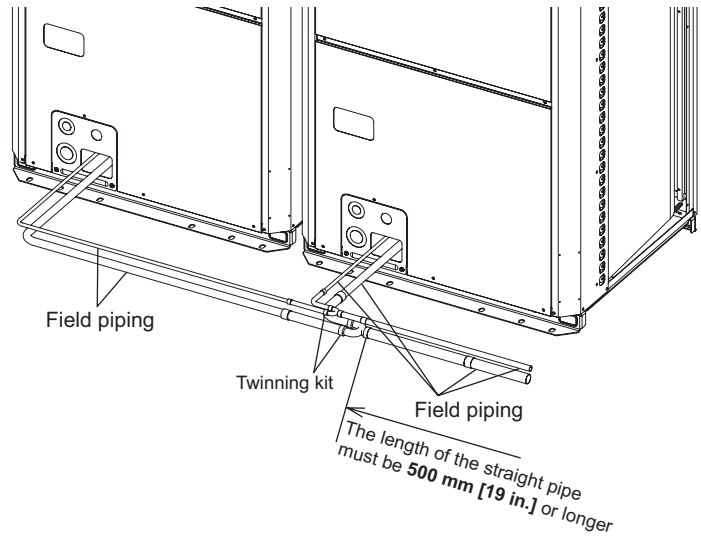

<PUHY-P264TSHMU/YSHMU>

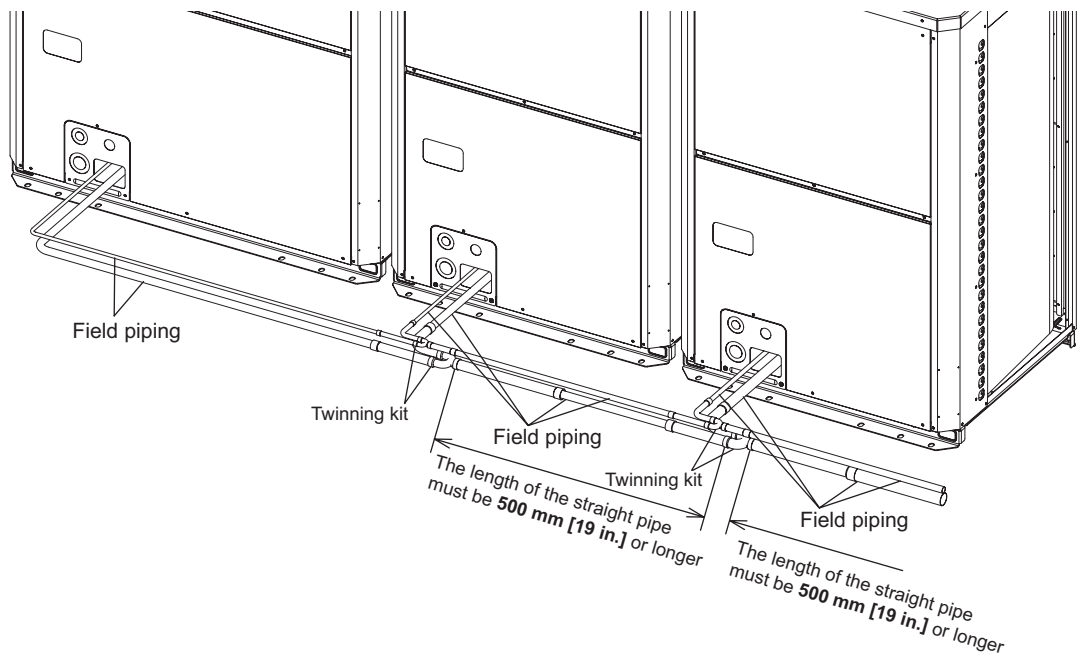

CAUTION

The length of the straight pipe must be 500mm[19in.] or longer. If not, it may cause improper operation.

4-4. Weather countermeasure

In cold and/or snowy areas, sufficient countermeasures to wind and snow damages should be taken for operating unit in normal and good condition in winter time. Even in the other areas, full consideration is required for installation of unit in order to prevent abnormal operations caused by wind or snow. **When rain and snow directly fall on unit in the case of air-conditioning operations in 10 or less degrees centigrade outdoor air (50 or less degrees fahrenheit outdoor air), mount inlet and outlet ducts on unit for assuring stable operations.**

Countermeasure to snow and wind

Prevention the Outdoor unit from wind and snow damages in cold or snowy areas, snow hood shown below is recommended and helpful.

• Snow hood

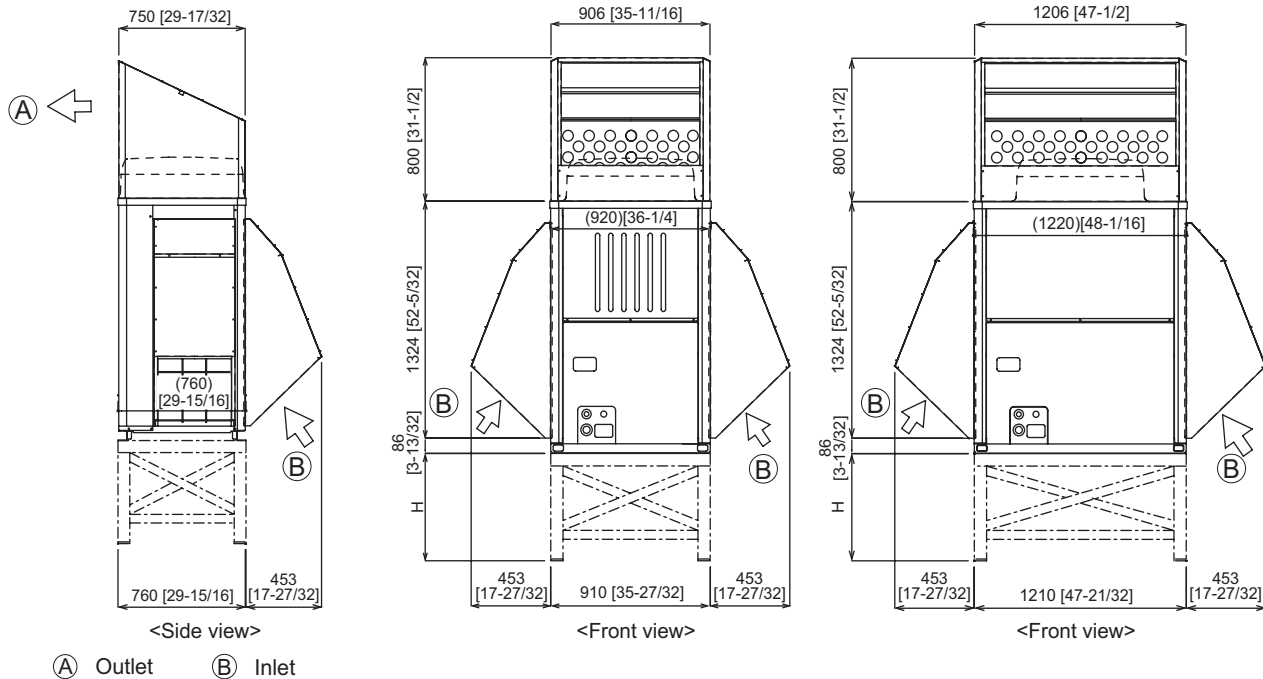

Note:

1. Height of frame base for snow damage prevention (H) shall be twice as high as expected snowfall. Width of frame base shall not exceed that of the unit. The frame base shall be made of angle steel, etc., and designed so that snow and wind slip through the structure. (If frame base is too wide, snow will be accumulated on it.)
2. Install unit so that wind will not directly lash against openings of inlet and outlet ducts.
3. Build frame base at customer referring to this figure.
 Material : Galvanized steel plate 1.2T [1/16 in. T]
 Painting : Overall painting with polyester powder
 Color : Munsell 5Y8/1 (same as that of unit)
4. To install units side by side, install a filler plate between the fan guard and the outlet-side snow hood as shown in Figure A.
 (The filler plate provided accommodates the installation pitch of between 30-80 mm [1-3/16~3-5/32 in.])
5. When the unit is used in a cold region and the heating operation is continuously performed for a long time when the outside air temperature is below freezing, install a heater to the unit base or take other appropriate measures to prevent water from freezing on the base.

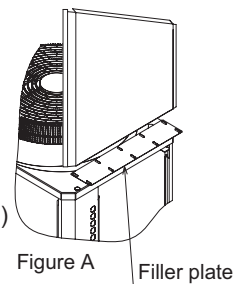

Countermeasure to wind

Referring to the figure shown below, take appropriate measures which will suit the actual situation of the place for installation. A unit installed alone is vulnerable to strong winds. Select the installation site carefully to minimize the effect of winds. To install a unit in a place where the wind always blows from the same direction, install the unit so that the outlet faces away from the direction of the wind.

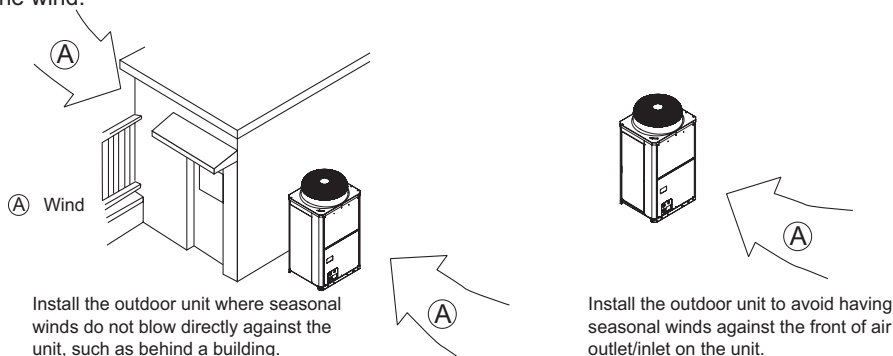

4-5. Caution on selecting outdoor units

Consult your dealer when the following issues on Y system are the key concern.

- Warm air may flow out from the indoor unit during heating Thermo-OFF.
- Refrigerant flow sound may occur in the rooms with low background noise such as hotel rooms, hospital rooms, bedrooms, or conference rooms.

To avoid the above issues on Y system, changing board settings on the indoor and outdoor units is required.

Ask AC&R Works for details.

The installer and/or air conditioning system specialist shall secure safety against refrigerant leakage according to local regulations or standards. The following standard may be applicable if no local regulation or standard is available.

5-1. Refrigerant property

R410A refrigerant is harmless and incombustible. The R410A is heavier than the indoor air in density. Leakage of the refrigerant in a room has possibility to lead to a hypoxia situation. Therefore, the Critical concentration specified below shall not be exceeded even if the leakage happens.

• Critical concentration

Critical concentration hereby is the refrigerant concentration in which no human body would be hurt if immediate measures can be taken when refrigerant leakage happens.

Critical concentration of R410A: 0.30kg/m³
(The weight of refrigeration gas per 1 m³ air conditioning space.);

* The Critical concentration is subject to ISO5149, EN378-1.

For the CITY MULTI system, the concentration of refrigerant leaked should not have a chance to exceed the Critical concentration in any situation.

5-2. Confirm the Critical concentration and take countermeasure

The maximum refrigerant leakage concentration (Rmax) is defined as the result of the possible maximum refrigerant weight (Wmax) leaked into a room divided by its room capacity (V). It is referable to Fig.5-1. The refrigerant of Outdoor unit here includes its original charge and additional charge at the site.

The additional charge is calculated according to "3-3 .Refrigerant charging calculation" and shall not be over charged at the site.

Procedure 5-2-1~3 tells how to confirm maximum refrigerant leakage concentration (Rmax) and how to take countermeasures against a possible leakage.

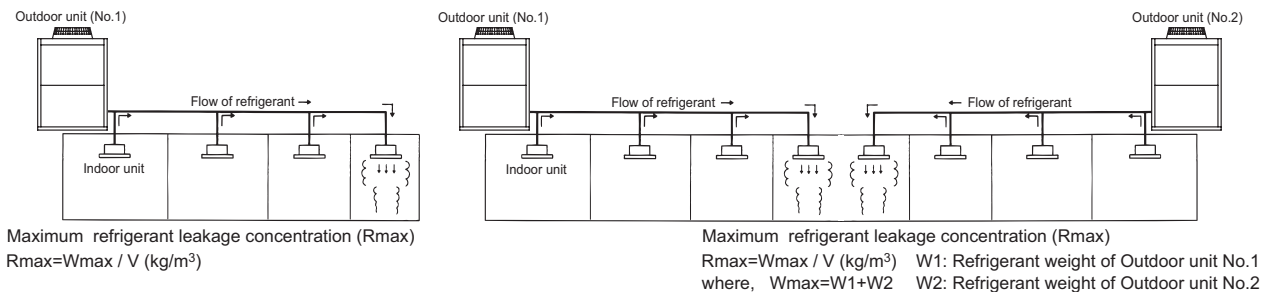

Fig. 5-1 The maximum refrigerant leakage concentration

5-2-1. Find the room capacity (V).

If a room having total opening area more than 0.15% of the floor area at a low position with another room/space, the two rooms/space are considered as one. The total space shall be added up.

5-2-2. Find the possible maximum leakage (Wmax) in the room. If a room has Indoor unit(s) from more than 1 Outdoor unit, add up the refrigerant of the Outdoor units.

5-2-3. Divide (Wmax) by (V) to get the maximum refrigerant leakage concentration (Rmax).

5-2-4. Find if there is any room in which the maximum refrigerant leakage concentration (Rmax) is over 0.30kg/m³.

If no, then the CITY MULTI is safe against refrigerant leakage.

If yes, following countermeasure is recommended to do at site.

Countermeasure 1: Let-out (making V bigger)

Design an opening of more than 0.15% of the floor area at a low position of the wall to let out the refrigerant whenever leaked.

e.g. make the upper and lower seams of door big enough.

Countermeasure 2: Smaller total charge (making Wmax smaller)

e.g. Avoid connecting more than 1 Outdoor unit to one room.

e.g. Using smaller model size but more Outdoor units.

e.g. Shorten the refrigerant piping as much as possible.

Countermeasure 3: Fresh air in from the ceiling (Ventilation)

As the density of the refrigerant is bigger than that of the air. Fresh air supply from the ceiling is better than air exhausting from the ceiling.

Fresh air supply solution refers to Fig.5-2~4.

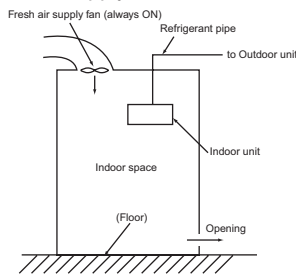

Fig.5-2. Fresh air supply always ON

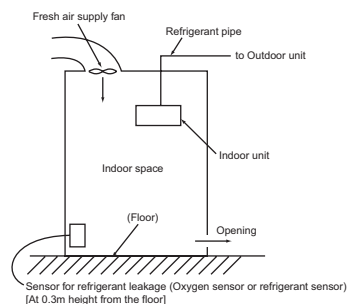

Fig.5-3. Fresh air supply upon sensor action

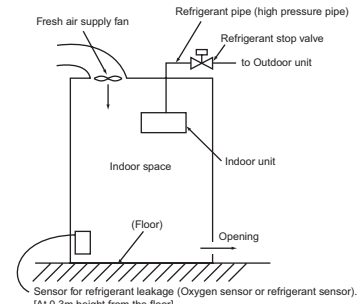

Fig.5-4. Fresh air supply and refrigerant shut-off upon sensor action

Note 1. Countermeasure 3 should be done in a proper way in which the fresh air supply shall be on whenever the leakage happens.

Note 2. In principle, MITSUBISHI ELECTRIC requires proper piping design, installation and air-tight testing after installation to avoid leakage happening.

In the area should earthquake happen, anti-vibration measures should be fully considered.

The piping should consider the extension due to the temperature variation.