

# CITY MULTI

## SYSTEM DESIGN WR2 SERIES

1. Electrical work.....	4 - 264
1-1.General cautions .....	4 - 264
1-2.Power supply for Indoor unit and Heat source unit.....	4 - 265
1-3.Power cable specifications .....	4 - 269
1-4.Power supply examples.....	4 - 270
2. M-NET control.....	4 - 272
2-1.Transmission cable length limitation.....	4 - 272
2-2.Transmission cable specifications .....	4 - 273
2-3.System configuration restrictions.....	4 - 274
2-4.Address setting.....	4 - 277
3. Piping Design.....	4 - 289
3-1.R410A Piping material .....	4 - 289
3-2.Piping Design .....	4 - 289
3-3.Refrigerant charging calculation .....	4 - 293
4. Installation.....	4 - 294
4-1.Requirement on installation site .....	4 - 294
4-2.Spacing.....	4 - 294
4-3.Piping direction .....	4 - 295
5. Installation information.....	4 - 296
5-1.General precautions .....	4 - 296
5-2.Precautions for Indoor unit .....	4 - 297
5-3.Precautions for Outdoor unit/Heat source unit .....	4 - 298
5-4.Precautions for Control-related items .....	4 - 299
6. Caution for refrigerant leakage .....	4 - 300
6-1.Refrigerant property.....	4 - 300
6-2.Confirm the Critical concentration and take countermeasure.....	4 - 300

## 1-1. General cautions

- ① Follow ordinance of your governmental organization for technical standard related to electrical equipment, wiring regulations, and guidance of each electric power company.
- ② Wiring for control (hereinafter referred to as transmission cable) shall be (50mm[1-5/8in] or more) apart from power source wiring so that it is not influenced by electric noise from power source wiring. (Do not insert transmission cable and power source wire in the same conduit.)
- ③ Be sure to provide designated grounding work to heat source unit.
- ④ Give some allowance to wiring for electrical part box of indoor and heat source unit, because the box is sometimes removed at the time of service work.
- ⑤ Never connect 100V, 208~230V, 460V power source to terminal block of transmission cable. If connected, electrical parts will be damaged.
- ⑥ Use 2-core shield cable for transmission cable. If transmission cables of different systems are wired with the same multicore cable, the resultant poor transmitting and receiving will cause erroneous operations.
- ⑦ When extending the transmission line, make sure to extend the shield cable as well.

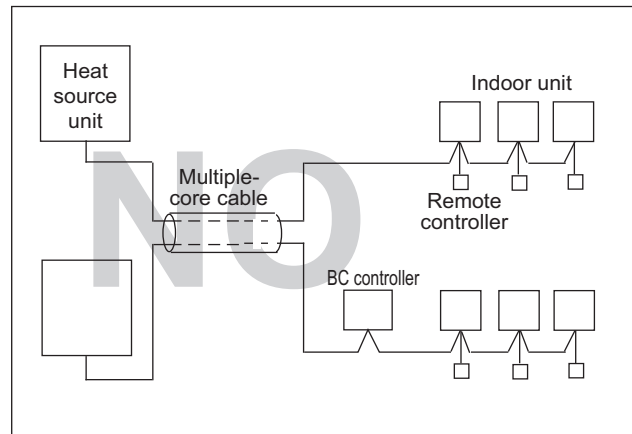
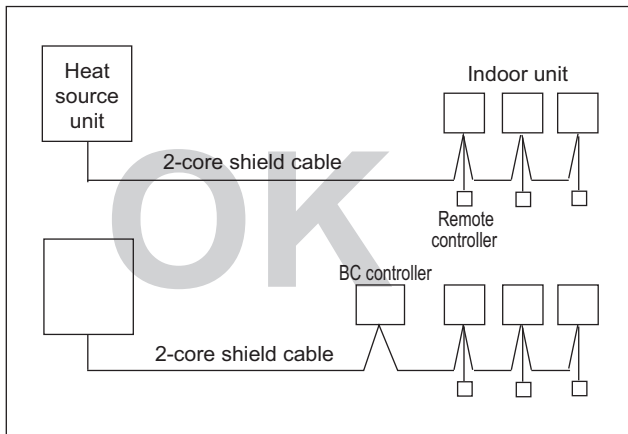

1-2. Power supply for Indoor unit and Heat source unit

1-2-1. Electrical characteristics of Indoor unit

Symbols: MCA : Minimum Circuit Ampacity (=1.25xFLA) FLA : Full Load Amps  
 IFM :Indoor Fan Motor Output : Fan motor rated output

Model	Indoor Unit			IFM				
	Hz	Volts	Voltage range	MCA(A)	Output(kW)	FLA(A)		
PLFY-P06NLMU-E	60Hz	208 / 230V	188 to 253V	0.43 / 0.47	0.015 / 0.015	0.34 / 0.37		
PLFY-P08NLMU-E				0.43 / 0.47	0.015 / 0.015	0.34 / 0.37		
PLFY-P12NLMU-E				0.43 / 0.47	0.015 / 0.015	0.34 / 0.37		
PLFY-P15NLMU-E				0.48 / 0.53	0.015 / 0.015	0.38 / 0.42		
PLFY-P18NLMU-E				0.49 / 0.54	0.020 / 0.020	0.39 / 0.43		
PLFY-P08NCMU-E			198 to 253V	0.29 / 0.29	0.015 / 0.015	0.23 / 0.23		
PLFY-P12NCMU-E				0.35 / 0.35	0.020 / 0.020	0.28 / 0.28		
PLFY-P15NCMU-E				0.35 / 0.35	0.020 / 0.020	0.28 / 0.28		
PLFY-P12NBMU-E				0.64 / 0.64	0.050 / 0.050	0.51 / 0.51		
PLFY-P15NBMU-E				0.64 / 0.64	0.050 / 0.050	0.51 / 0.51		
PLFY-P18NBMU-E				0.64 / 0.64	0.050 / 0.050	0.51 / 0.51		
PLFY-P24NBMU-E				0.64 / 0.64	0.050 / 0.050	0.51 / 0.51		
PLFY-P30NBMU-E				0.64 / 0.64	0.050 / 0.050	0.51 / 0.51		
PLFY-P36NBMU-E				1.25 / 1.25	0.120 / 0.120	1.00 / 1.00		
PMFY-P06NBMU-E				60Hz	208 / 230V	198 to 253V	0.25 / 0.25	0.028 / 0.028
PMFY-P08NBMU-E			0.25 / 0.25				0.028 / 0.028	0.20 / 0.20
PMFY-P12NBMU-E	0.26 / 0.26	0.028 / 0.028	0.21 / 0.21					
PMFY-P15NBMU-E	0.33 / 0.33	0.028 / 0.028	0.26 / 0.26					
PEFY-P06NMAU-E3	60Hz	208 / 230V	188 to 253V	1.05 / 1.05	0.085 / 0.085	0.84 / 0.84		
PEFY-P08NMAU-E3				1.05 / 1.05	0.085 / 0.085	0.84 / 0.84		
PEFY-P12NMAU-E3				1.20 / 1.20	0.085 / 0.085	0.96 / 0.96		
PEFY-P15NMAU-E3				1.45 / 1.45	0.085 / 0.085	1.16 / 1.16		
PEFY-P18NMAU-E3				1.56 / 1.56	0.085 / 0.085	1.25 / 1.25		
PEFY-P24NMAU-E3				2.73 / 2.73	0.121 / 0.121	2.18 / 2.18		
PEFY-P27NMAU-E3				2.73 / 2.73	0.121 / 0.121	2.18 / 2.18		
PEFY-P30NMAU-E3				2.73 / 2.73	0.121 / 0.121	2.18 / 2.18		
PEFY-P36NMAU-E3				3.32 / 3.32	0.244 / 0.244	2.66 / 2.66		
PEFY-P48NMAU-E3				3.41 / 3.41	0.244 / 0.244	2.73 / 2.73		
PEFY-P54NMAU-E3				3.31 / 3.31	0.244 / 0.244	2.65 / 2.65		
PEFY-P06NMSU-E	60Hz	208 / 230V	188 to 253V	0.47 / 0.50	0.023 / 0.023	0.32 / 0.31		
PEFY-P08NMSU-E				0.47 / 0.50	0.023 / 0.023	0.41 / 0.39		
PEFY-P12NMSU-E				0.68 / 0.74	0.032 / 0.032	0.46 / 0.43		
PEFY-P15NMSU-E				1.20 / 1.33	0.130 / 0.130	0.47 / 0.45		
PEFY-P18NMSU-E				1.20 / 1.33	0.130 / 0.130	0.64 / 0.60		
PEFY-P24NMSU-E				1.57 / 1.73	0.180 / 0.180	0.88 / 0.83		
PEFY-P15NMHU-E2				1.63 / 1.50	0.17	1.30 / 1.20		
PEFY-P18NMHU-E2				1.63 / 1.50	0.17	1.30 / 1.20		
PEFY-P24NMHU-E2				2.11 / 1.83	0.25	1.69 / 1.46		
PEFY-P27NMHU-E2				2.35 / 2.13	0.26	1.88 / 1.70		
PEFY-P30NMHU-E2				2.70 / 2.45	0.31	2.16 / 1.96		
PEFY-P36NMHU-E2				4.16 / 3.67	0.49	3.32 / 2.94		
PEFY-P48NMHU-E2				4.16 / 3.67	0.49	3.32 / 2.94		
PEFY-P54NMHU-E2				4.18 / 3.69	0.55	3.34 / 2.95		
PEFY-P72NMHSU-E				187 to 253V	7.7	0.87	6.2	
PEFY-P96NMHSU-E			8.2		0.87	6.6		

S.D. WR2

Symbols: MCA : Minimum Circuit Ampacity (=1.25xFLA) FLA : Full Load Amps

IFM :Indoor Fan Motor Output : Fan motor rated output

Model	Indoor Unit			IFM		
	Hz	Volts	Voltage range	MCA(A)	Output(kW)	FLA(A)
PCFY-P15NKMU-E	60Hz	208 / 230V	198 to 253V	0.44 / 0.44	0.090 / 0.090	0.35 / 0.35
PCFY-P24NKMU-E				0.52 / 0.52	0.095 / 0.095	0.41 / 0.41
PCFY-P30NKMU-E				1.22 / 1.22	0.160 / 0.160	0.97 / 0.97
PCFY-P36NKMU-E				1.22 / 1.22	0.160 / 0.160	0.97 / 0.97
PKFY-P06NBMU-E2	60Hz	208 / 230V	198 to 253V	0.19 / 0.19	0.008 / 0.008	0.15 / 0.15
PKFY-P08NHMU-E2				0.38 / 0.38	0.030 / 0.030	0.30 / 0.30
PKFY-P12NHMU-E2				0.38 / 0.38	0.030 / 0.030	0.30 / 0.30
PKFY-P15NHMU-E2				0.38 / 0.38	0.030 / 0.030	0.30 / 0.30
PKFY-P18NHMU-E2				0.38 / 0.38	0.030 / 0.030	0.30 / 0.30
PKFY-P24NKMU-E2				0.63 / 0.63	0.056 / 0.056	0.50 / 0.50
PKFY-P30NKMU-E2				0.63 / 0.63	0.056 / 0.056	0.50 / 0.50
PFFY-P06NEMU-E	60Hz	208 / 230V	188 to 253V	0.32 / 0.34	0.015 / 0.015	0.25 / 0.27
PFFY-P08NEMU-E				0.32 / 0.34	0.015 / 0.015	0.25 / 0.27
PFFY-P12NEMU-E				0.34 / 0.38	0.018 / 0.018	0.27 / 0.30
PFFY-P15NEMU-E				0.40 / 0.44	0.030 / 0.030	0.32 / 0.35
PFFY-P18NEMU-E				0.48 / 0.53	0.035 / 0.035	0.38 / 0.42
PFFY-P24NEMU-E				0.59 / 0.64	0.063 / 0.063	0.47 / 0.51
PFFY-P06NRMU-E	60Hz	208 / 230V	188 to 253V	0.32 / 0.34	0.015 / 0.015	0.25 / 0.27
PFFY-P08NRMU-E				0.32 / 0.34	0.015 / 0.015	0.25 / 0.27
PFFY-P12NRMU-E				0.34 / 0.38	0.018 / 0.018	0.27 / 0.30
PFFY-P15NRMU-E				0.40 / 0.44	0.030 / 0.030	0.32 / 0.35
PFFY-P18NRMU-E				0.48 / 0.53	0.035 / 0.035	0.38 / 0.42
PFFY-P24NRMU-E				0.59 / 0.64	0.063 / 0.063	0.47 / 0.51

## 1-2-2. Electrical characteristics of Heat source unit

Symbols: MCA : Minimum Circuit Ampacity  
 SC : Starting Current RLA : Rated Load Amps

### PQRY-P-T(S)HMU

Model	Unit Combination	Heat source unit						Compressor	
		Hz	Volts	Voltage range	RLA(A)	MCA(A)	Max.Fuse(A)	Output(kW)	SC(A)
PQRY-P72THMU-A	-	60Hz	208/230V	188 to 253V	12.6/11.4	16/15	25/20	4.5	15
PQRY-P96THMU-A	-				18.0/16.2	23/21	40/30	6.2	15
PQRY-P120THMU-A	-				23.6/21.4	30/27	50/40	8.5	15
PQRY-P144TSHMU-A	PQRY-P72THMU-A				12.6/11.4	16/15	25/20	4.5	15
	PQRY-P72THMU-A				12.6/11.4	16/15	25/20	4.5	15
PQRY-P168TSHMU-A	PQRY-P72THMU-A				12.6/11.4	16/15	25/20	4.5	15
	PQRY-P96THMU-A				18.0/16.2	23/21	40/30	6.2	15
PQRY-P192TSHMU-A	PQRY-P96THMU-A				18.0/16.2	23/21	40/30	6.2	15
	PQRY-P96THMU-A				18.0/16.2	23/21	40/30	6.2	15
PQRY-P216TSHMU-A	PQRY-P96THMU-A				18.0/16.2	23/21	40/30	6.2	15
	PQRY-P120THMU-A				23.6/21.4	30/27	50/40	8.5	15
PQRY-P240TSHMU-A	PQRY-P120THMU-A				23.6/21.4	30/27	50/40	8.5	15
	PQRY-P120THMU-A				23.6/21.4	30/27	50/40	8.5	15

### PQRY-P-Y(S)HMU

Model	Unit Combination	Heat source unit						Compressor	
		Hz	Volts	Voltage range	RLA(A)	MCA(A)	Max.Fuse(A)	Output(kW)	SC(A)
PQRY-P72YHMU-A	-	60Hz	460V	414 to 506V	5.7	8	15	4.6	7
PQRY-P96YHMU-A	-				8.1	11	15	6.3	7
PQRY-P120YHMU-A	-				10.7	14	20	8.5	7
PQRY-P144YSHMU-A	PQRY-P72YHMU-A				5.7	8	15	4.6	7
	PQRY-P72YHMU-A				5.7	8	15	4.6	7
PQRY-P168YSHMU-A	PQRY-P72YHMU-A				5.7	8	15	4.6	7
	PQRY-P96YHMU-A				8.1	11	15	6.3	7
PQRY-P192YSHMU-A	PQRY-P96YHMU-A				8.1	11	15	6.3	7
	PQRY-P96YHMU-A				8.1	11	15	6.3	7
PQRY-P216YSHMU-A	PQRY-P96YHMU-A				8.1	11	15	6.3	7
	PQRY-P120YHMU-A				10.7	14	20	8.5	7
PQRY-P240YSHMU-A	PQRY-P120YHMU-A				10.7	14	20	8.5	7
	PQRY-P120YHMU-A				10.7	14	20	8.5	7

## 1-2-3. Electrical characteristics of BC controller

Symbols: MCA : Minimum Circuit Ampacity

FLA : Full Load Amps RLA : Rated Load Amps

Model	Hz	Volts	Voltage range	MCA(A)	FLA(A)	RLA(A)
CMB-P104NU-G	60Hz	208 / 230V	198 to 253V	0.36 / 0.33	15 / 15	0.29 / 0.26
CMB-P105NU-G				0.44 / 0.40	15 / 15	0.35 / 0.32
CMB-P106NU-G				0.52 / 0.47	15 / 15	0.41 / 0.37
CMB-P108NU-G				0.68 / 0.61	15 / 15	0.54 / 0.49
CMB-P1010NU-G				0.83 / 0.75	15 / 15	0.66 / 0.60
CMB-P1013NU-G				1.08 / 0.97	15 / 15	0.86 / 0.77
CMB-P1016NU-G				1.30 / 1.18	15 / 15	1.04 / 0.94
CMB-P108NU-GA				0.68 / 0.61	15 / 15	0.54 / 0.49
CMB-P1010NU-GA				0.83 / 0.75	15 / 15	0.66 / 0.60
CMB-P1013NU-GA				1.08 / 0.97	15 / 15	0.86 / 0.77
CMB-P1016NU-GA				1.30 / 1.18	15 / 15	1.04 / 0.94
CMB-P104NU-GB				0.32 / 0.29	15 / 15	0.25 / 0.23
CMB-P108NU-GB				0.64 / 0.58	15 / 15	0.51 / 0.46
CMB-P1016NU-HA			1.65 / 1.93	15 / 15	1.32 / 1.54	
CMB-P1016NU-HB			2.22 / 1.71	15 / 15	1.17 / 1.37	

## 1-3. Power cable specifications

Thickness of wire for main power supply, capacities of the switch and system impedance

	Model	Minimum wire thickness (mm <sup>2</sup> /AWG)			Breaker for current leakage	Switch (A)		Breaker for wiring (NFB)
		Main cable	Branch	Ground		Capacity	Fuse	
Heat source unit	PQRY-P72THMU-A	3.3/12	-	3.3/12	20A 30mA or 100mA 0.1sec. or less	20	25	20
	PQRY-P96THMU-A	5.3/10	-	5.3/10	30A 30mA or 100mA 0.1sec. or less	30	40	30
	PQRY-P120THMU-A	8.4/8	-	8.4/8	40A 100mA 0.1sec. or less	40	50	40
Total operating current of the indoor unit	F0 = 15 or less *1	2.1/14	2.1/14	2.1/14	15A current sensitivity *2	15	15	15
	F0 = 20 or less *1	3.3/12	3.3/12	3.3/12	20A current sensitivity *2	20	20	20
	F0 = 30 or less *1	5.3/10	5.3/10	5.3/10	30A current sensitivity *2	30	30	30

	Model	Minimum wire thickness (mm <sup>2</sup> /AWG)			Breaker for current leakage	Switch (A)		Breaker for wiring (NFB)
		Main cable	Branch	Ground		Capacity	Fuse	
Heat source unit	PQRY-P72YHMU-A	2.1/14	-	2.1/14	15A 30mA or 100mA 0.1sec. or less	15	15	15
	PQRY-P96YHMU-A	2.1/14	-	2.1/14	15A 30mA or 100mA 0.1sec. or less	15	15	15
	PQRY-P120YHMU-A	3.3/12	-	3.3/12	20A 30mA or 100mA 0.1sec. or less	20	20	20
Total operating current of the indoor unit	F0 = 15 or less *1	2.1/14	2.1/14	2.1/14	15A current sensitivity *2	15	15	15
	F0 = 20 or less *1	3.3/12	3.3/12	3.3/12	20A current sensitivity *2	20	20	20
	F0 = 30 or less *1	5.3/10	5.3/10	5.3/10	30A current sensitivity *2	30	30	30

\*1 Please take the larger of F1 or F2 as the value for F0.

F1 = Total operating maximum current of the indoor units × 1.2

F2 = {V1 × (Quantity of Type1)/C} + {V1 × (Quantity of Type2)/C} + {V1 × (Quantity of Type3)/C} + {V1 × (Quantity of Others)/C}

Indoor unit		V1	V2
Type1	PLFY-NBMU, PMFY-NBMU, PEFY-NMSU, PCFY-NKMU, PKFY-NHMU, PKFY-NKMU	18.6	2.4
Type2	PEFY-NMAU	38	1.6
Type3	PEFY-NMHSU	13.8	4.8
Others	Other indoor unit	0	0

C: Multiple of tripping current at tripping time 0.01s

Please pick up "C" from the tripping characteristic of the breaker.

<Example of "F2" calculation>

\*Condition PEFY-NMSU × 4 + PEFY-NMAU × 1, C = 8 (refer to right sample chart)

F2 = 18.6 × 4/8 + 38 × 1/8

= 14.05

→16 A breaker (Tripping current = 8 × 16 A at 0.01s)

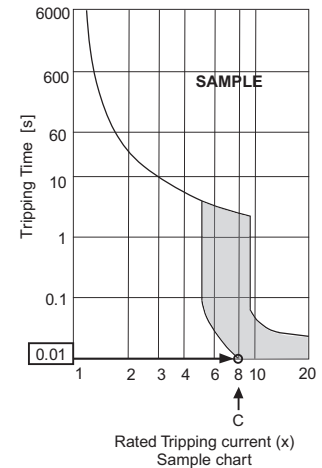

S.D. WR2

\*2 Current sensitivity is calculated using the following formula.

G1 = (V2 × Quantity of Type1) + (V2 × Quantity of Type2) + (V2 × Quantity of Type3) + (V2 × Quantity of Others) + (V3 × Wire length [km])

G1	Current sensitivity	Wire thickness	V3
30 or less	30 mA 0.1sec or less	1.5 mm <sup>2</sup>	48
100 or less	100 mA 0.1sec or less	2.5 mm <sup>2</sup>	56
		4.0 mm <sup>2</sup>	66

- Use dedicated power supplies for the heat source unit and indoor unit. Ensure OC and OS are wired individually.
- Bear in mind ambient conditions (ambient temperature, direct sunlight, rain water, etc.) when proceeding with the wiring and connections.
- The wire size is the minimum value for metal conduit wiring. If the voltage drops, use a wire that is one rank thicker in diameter. Make sure the power-supply voltage does not drop more than 10%. Make sure that the voltage imbalance between the phases is 2% or less.
- Specific wiring requirements should adhere to the wiring regulations of the region.
- Power supply cords of parts of appliances for heat source use shall not be lighter than polychloroprene sheathed flexible cord (design 245 IEC57). For example, use wiring such as YZW.
- A switch with at least 3 mm [1/8 in.] contact separation in each pole shall be provided by the Air Conditioner installer.

### ⚠ WARNING

- Be sure to use specified wires for connections and ensure no external force is imparted to terminal connections. If connections are not fixed firmly, heating or fire may result.
- Be sure to use the appropriate type of overcurrent protection switch. Note that generated overcurrent may include some amount of direct current.

### ⚠ CAUTION

- The breakers for current leakage should support Inverter circuit. (e.g. Mitsubishi Electric's NV-C series or equivalent). If no earth leakage breaker is installed, it may cause an electric shock.
- Breakers for current leakage should combine using of switch.
- Do not use anything other than a breaker with the correct capacity. Using a breaker of too large capacity may cause malfunction or fire.
- If a large electric current flows due to malfunction or faulty wiring, earth-leakage breakers on the unit side and on the upstream side of the power supply system may both operate. Depending on the importance of the system, separate the power supply system or take protective coordination of breakers.

1-4. Power supply examples

The local standards and/or regulations is applicable at a higher priority.

1-4-1. PQRY-P72, 96, 120THMU/YHMU

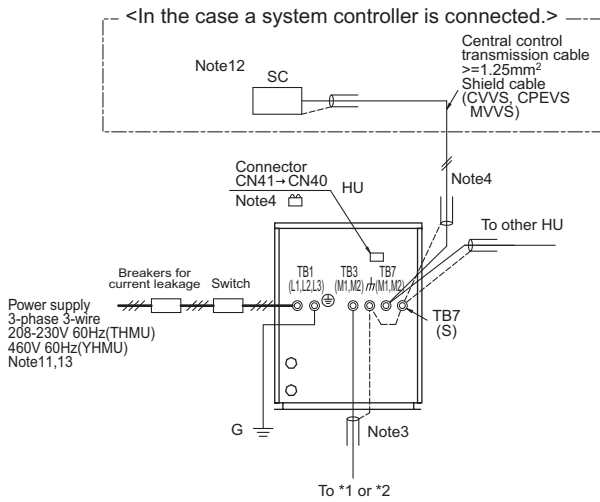

Note:

- 1 The transmission cable is not-polarity double-wire.
- 2 Symbol Ⓞ means a screw terminal for wiring.
- 3 The shield wire of transmission cable should be connected to the grounding terminal at Heat source unit. All shield wire of M-Net transmission cable among indoor units should be connected to the S terminal at Indoor unit or all shield wire should be connected together.
- 4 The broken line at the scheme means shield wire.
- 5 When the Heat source unit connected with system controller, power-supply to TB7 of the heat source unit(s) is needed. The connector change from CN41 to CN40 at one of the heat source units will enable the heat source unit to supply power to TB7, or an extra power supply unit PAC-SC51KUA should be used. The transmission cable (above 1.25mm<sup>2</sup> shielded, CVVS/CPEVS/MVVS) among Heat source units and system controllers is called central control transmission cable. The shield wire of the central control transmission cable must be grounded at the Heat source unit whose CN41 is changed to CN40. When the power supply unit PAC-SC51KUA is used, connect the shielded cable to the ground terminal on the PAC-SC51KUA.
- 6 MA R/C transmission cable (0.3-1.25mm<sup>2</sup>) must be less than 200m in length, while ME R/C transmission cable (0.3-1.25mm<sup>2</sup>) must be less than 10m in length. But transmission cable to the ME R/C can be extend using a M-NET cable ( $\geq 1.25\text{mm}^2$ ) when the length is counted in the M-Net length.
- 7 To wire PAC-YT53CRAU, use a wire with a diameter of 0.3mm<sup>2</sup> [AWG 22].
- 8 MA remote controller and ME remote controller should not be grouped together.
- 9 If using 1 or 2 (main/sub) MA remote controller to control more than 1 Indoor unit, use MA transmission cable to connect all the TB15 terminals of the Indoor units. It is called "Grouping".
- 10 If using 1 or 2 (main/sub) ME remote controller control more than 1 indoor unit, set address to Indoor unit and ME remote controller. For the method, refer to 2-4. "Address setting".
- 11 Indoor board consumes power from TB3. The power balance should be considered according to System Design 2-3 "System configuration restrictions".
- 12 If Transmission booster is needed, be sure to connect the shield wires to the both sides to the booster.
- 13 The critical current for choosing power source equipment is approximate 1.4 times of total rated current of the Heat source unit(s) or Indoor unit(s).
- 14 When System controller (SC) is connected to the system, turn the SW2-1 on.
- 15 The phases of electricity power must be confirmed to be right used. Phase-reverse, or phase-missing could break the controllers.

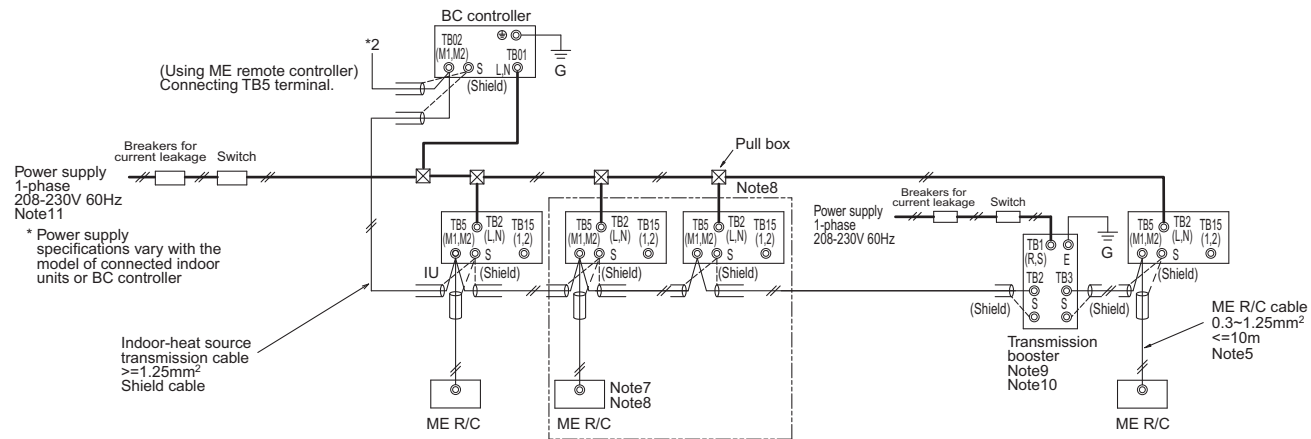
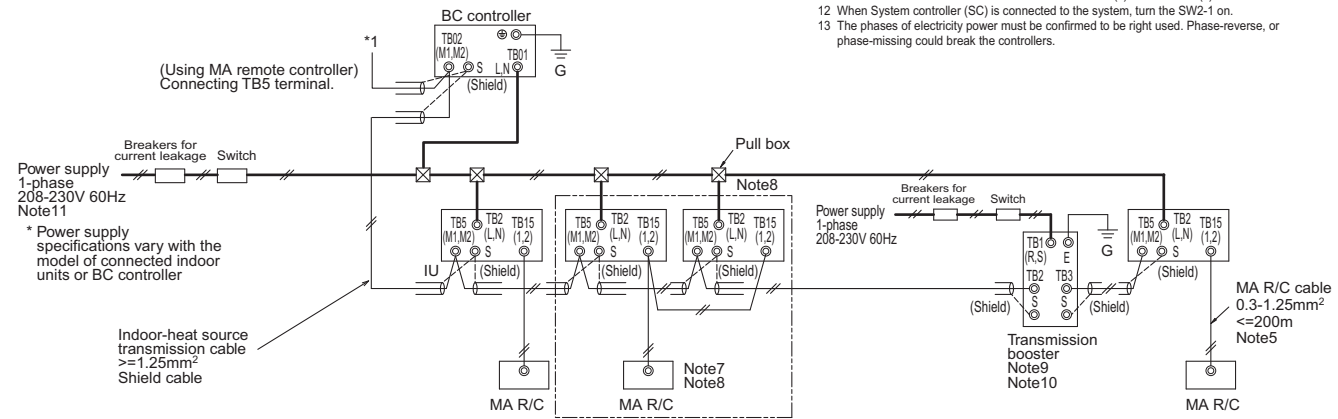

Symbol	Model	Breakers for current leakage *1, *2, *4	Switch			Minimum Wire thickness		
			BKC <A>	OCP*3, *4 <A>	Switch*4 (NFB) <A>	Power wire <mm <sup>2</sup> /AWG>	G wire <mm <sup>2</sup> /AWG>	
BKC	Breaker capacity	PQRY-P72THMU	20 A 30 mA or 100 mA 0.1 sec. or less	20	20	20	3.3/12	3.3/12
OCP	Over-current protector	PQRY-P96THMU	30 A 30 mA or 100 mA 0.1 sec. or less	30	30	30	5.3/10	5.3/10
NFB	Non-fuse breaker	PQRY-P120THMU	40 A 100 mA 0.1 sec. or less	40	40	40	8.4/8	8.4/8
HU	Heat source unit	PQRY-P72YHMU	15 A 30 mA or 100 mA 0.1 sec. or less	15	15	15	2.1/14	2.1/14
IU	Indoor unit	PQRY-P96YHMU	15 A 30 mA or 100 mA 0.1 sec. or less	15	15	15	2.1/14	2.1/14
SC	System controller	PQRY-P120YHMU	20 A 30 mA or 100 mA 0.1 sec. or less	20	20	20	3.3/12	3.3/12

\*1 The breakers for current leakage should support Inverter circuit. (e.g. Mitsubishi Electric's NV-C series or equivalent).

\*2 Breakers for current leakage should combine using of switch.

\*3 It shows data for B-type fuse of the breaker for current leakage.

\*4 If a large electric current flows due to malfunction or faulty wiring, earth-leakage breakers on the unit side and on the centralized controller side may both operate.

Depending on the importance of the system, separate the power supply system or take protective coordination of breakers.



The local standards and/or regulations is applicable at a higher priority.  
 1-4-2. PQRYP144, 168, 192, 216, 240TSHMU/YSHMU

<In the case a system controller is connected.>

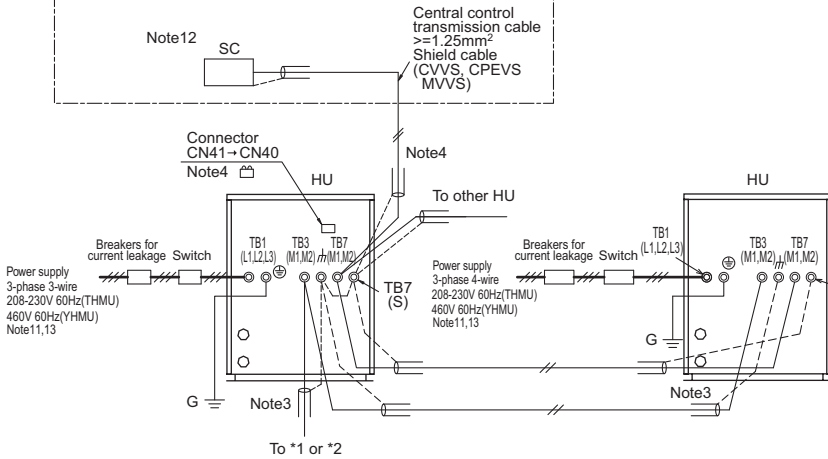

- Note:
- The transmission cable is not-polarity double-wire.
  - Symbol Ⓞ means a screw terminal for wiring.
  - The shield wire of transmission cable should be connected to the grounding terminal at Heat source unit. All shield wire of M-Net transmission cable among Indoor units should be connected to the S terminal at Indoor unit or all shield wire should be connected together.  
The broken line at the scheme means shield wire.
  - When the Heat source unit connected with system controller, power-supply to TB7 of the heat source unit(s) is needed. The connector change from CN41 to CN40 at one of the heat source units will enable the heat source unit to supply power to TB7, or an extra power supply unit PAC-SC51KUA should be used. The transmission cable (above 1.25mm², shielded, CVVS/CPEVS/MVVS) among Heat source units and system controllers is called central control transmission cable. The shield wire of the central control transmission cable must be grounded at the Heat source unit whose CN41 is changed to CN40. When the power supply unit PAC-SC51KUA is used, connect the shielded cable to the ground terminal on the PAC-SC51KUA.
  - MA R/C transmission cable (0.3-1.25mm²) must be less than 200m in length, while ME R/C transmission cable (0.3-1.25mm²) must be less than 10m in length. But transmission cable to the ME R/C can be extended using a M-NET cable (>=1.25mm²) when the length is counted in the M-Net length.
  - To wire PAC-YT53CRAU, use a wire with a diameter of 0.3mm² [AWG 22].
  - MA remote controller and ME remote controller should not be grouped together.
  - If using 1 or 2 (main/sub) MA remote controller to control more than 1 Indoor unit, use MA transmission cable to connect all the TB15 terminals of the Indoor units. It is called "Grouping".  
If using 1 or 2 (main/sub) ME remote controller control more than 1 indoor unit, set address to Indoor unit and ME remote controller. For the method, refer to 2-4. "Address setting".
  - Indoor board consumes power from TB3. The power balance should be considered according to System Design 2-3 "System configuration restrictions".
  - If transmission booster is needed, be sure to connect the shield wires to the both sides to the booster.
  - The critical current for choosing power source equipment is approximate 1.4 times of total rated current of the Heat source unit(s) or Indoor unit(s).
  - When System controller (SC) is connected to the system, turn the SW2-1 on.
  - The phases of electricity power must be confirmed to be right used. Phase-reverse, or phase-missing could break the controllers.

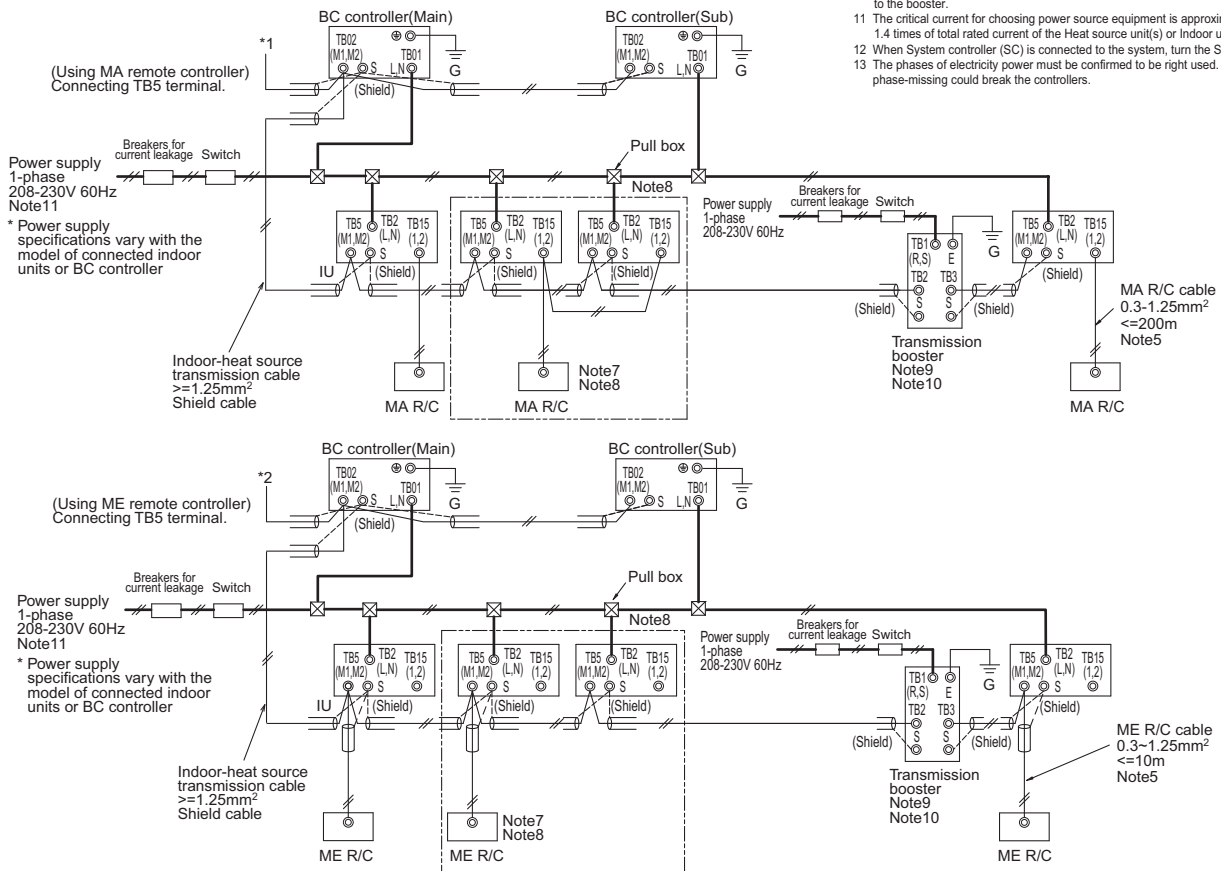

Symbol	Model	Breakers for current leakage *1, *2, *4	Switch			Minimum Wire thickness	
			BKC <A>	OCP*3, *4 <A>	Switch*4 (NFB) <A>	Power wire <mm²/AWG>	G wire <mm²/AWG>
BKC	Breaker capacity	PQRYP72THMU	20 A 30 mA or 100 mA 0.1 sec. or less	20	20	3.3/12	3.3/12
OCP	Over-current protector	PQRYP96THMU	30 A 30 mA or 100 mA 0.1 sec. or less	30	30	5.3/10	5.3/10
NFB	Non-fuse breaker	PQRYP120THMU	40 A 100 mA 0.1 sec. or less	40	40	8.4/8	8.4/8
HU	Heat source unit	PQRYP72YHMU	15 A 30 mA or 100 mA 0.1 sec. or less	15	15	2.1/14	2.1/14
IU	Indoor unit	PQRYP96YHMU	15 A 30 mA or 100 mA 0.1 sec. or less	15	15	2.1/14	2.1/14
SC	System controller	PQRYP120YHMU	20 A 30 mA or 100 mA 0.1 sec. or less	20	20	3.3/12	3.3/12

\*1 The breakers for current leakage should support Inverter circuit. (e.g. Mitsubishi Electric's NV-C series or equivalent).  
 \*2 Breakers for current leakage should combine using of switch.  
 \*3 It shows data for B-type fuse of the breaker for current leakage.  
 \*4 If a large electric current flows due to malfunction or faulty wiring, earth-leakage breakers on the unit side and on the centralized controller side may both operate.  
 Depending on the importance of the system, separate the power supply system or take protective coordination of breakers.

S.D. WR2

2-1. Transmission cable length limitation

2-1-1. Using MA Remote controller

MA remote controller refers to Simple MA remote controller and wireless remote controller.

Long transmission cable causes voltage down, therefore, the length limitation should be obeyed to secure proper transmission.

Max. length via Heat source (M-NET cable)	$L_1+L_2+L_3+L_4, L_1+L_2+L_6+L_7, L_3+L_4+L_6+L_7$	$\leq 500\text{m}[1640\text{ft.}]$	1.25mm <sup>2</sup> [AWG16] or thicker
Max. length to Heat source (M-NET cable)	$L_1+L_8, L_3+L_4, L_6, L_2+L_6+L_8, L_7$	$\leq 200\text{m}[656\text{ft.}]$	1.25mm <sup>2</sup> [AWG16] or thicker
Max. length from MA to Indoor	$a_1+a_2, a_1+a_2+a_3+a_4$	$\leq 200\text{m}[656\text{ft.}]$	0.3-1.25 mm <sup>2</sup> [AWG22-16]
24VDC to AG-150A-A	n	$\leq 50\text{m}[164\text{ft.}]$	0.75-2.0 mm <sup>2</sup> [AWG18-14]

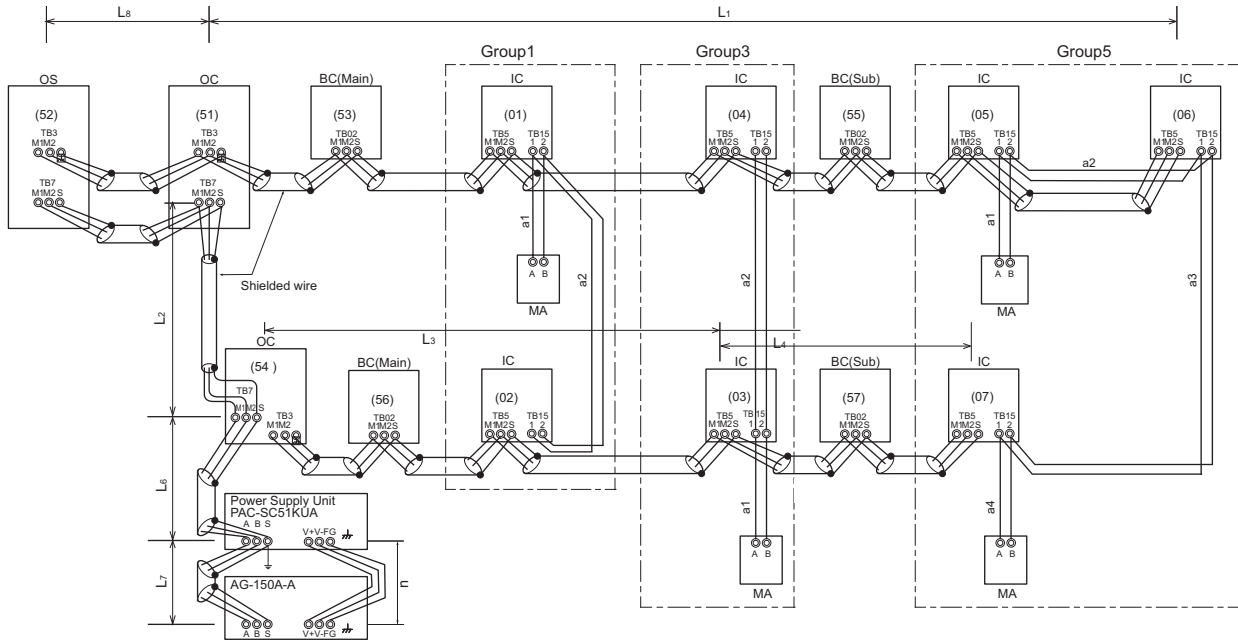

NOTE  
Do not daisy-chain remote controllers.

OC, OS: Heat source unit controller; IC: Indoor unit controller; ME: ME remote controller

2-1-2. Using ME Remote controller

ME remote controller refers to Smart ME Controller.

Long transmission cable causes voltage down, therefore, the length limitation should be obeyed to secure proper transmission.

Max. length via Heat source (M-NET cable)	$L_1+L_2+L_3+L_4, L_1+L_2+L_6+L_7, L_1+L_2+L_3+L_5, L_3+L_4+L_6+L_7$	$\leq 500\text{m}[1640\text{ft.}]$	1.25mm <sup>2</sup> [AWG16] or thicker
Max. length to Heat source (M-NET cable)	$L_1+L_8, L_3+L_4, L_6, L_2+L_6+L_8, L_7, L_3+L_5$	$\leq 200\text{m}[656\text{ft.}]$	1.25mm <sup>2</sup> [AWG16] or thicker
Max. length from ME to Indoor	$e_1, e_2+e_3, e_4$	$\leq 10\text{m}[32\text{ft.}] * 1$	0.3-1.25 mm <sup>2</sup> [AWG22-16] * 1
24VDC to AG-150A-A	n	$\leq 50\text{m}[164\text{ft.}]$	0.75-2.0 mm <sup>2</sup> [AWG18-14]

\*1. If the length from ME to Indoor exceed 10m, use 1.25 mm<sup>2</sup> [AWG16] shielded cable, but the total length should be counted into Max. length via Heat source.

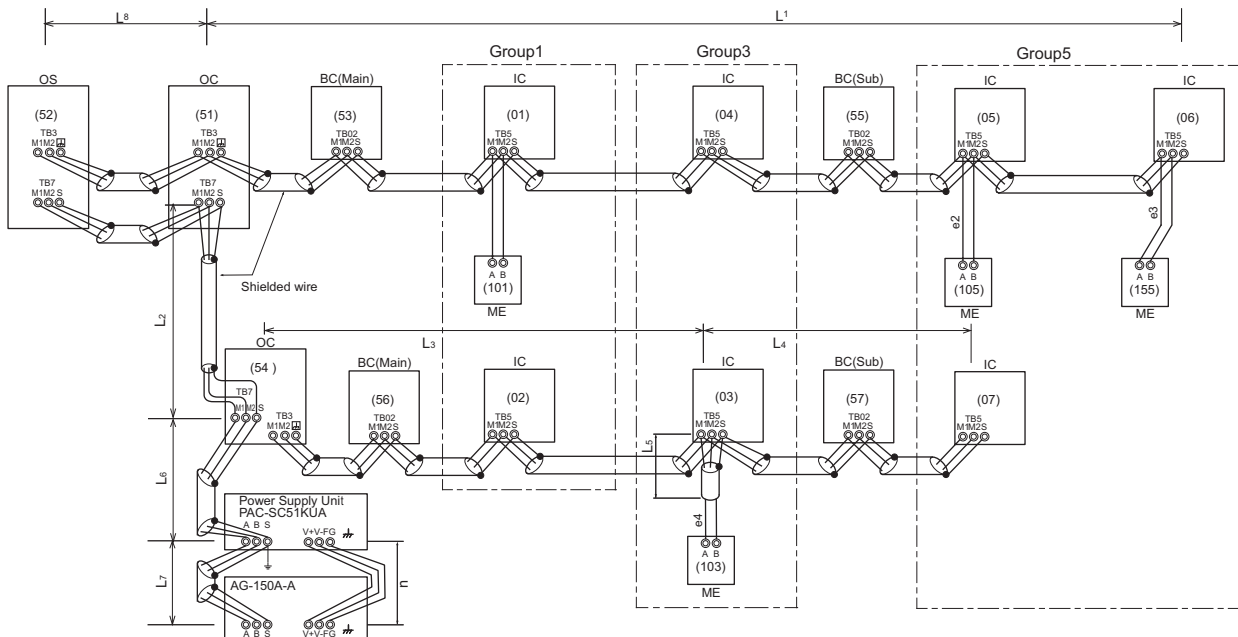

NOTE  
Do not daisy-chain remote controllers.

OC, OS: Heat source unit controller; IC: Indoor unit controller; ME: ME remote controller

S.D. WR2

2-2. Transmission cable specifications

	Transmission cables (Li)	ME Remote controller cables	MA Remote controller cables
Type of cable	Shielding wire (2-core) CVVS, CPEVS or MVVS	Sheathed 2-core cable (unshielded) CVV	
Cable size	More than 1.25mm <sup>2</sup> [AWG16]	0.3~1.25mm <sup>2</sup> [AWG22~16]*2	0.3~1.25mm <sup>2</sup> [AWG22~16]*1 *2
Remarks	—	When 10m [32ft] is exceeded, use cables with the same specification as transmission cables.	Max length : 200m [656ft]

\*1 To wire PAC-YT53CRAU, use a wire with a diameter of 0.3 mm<sup>2</sup> [AWG22]

\*2 The use of cables 0.75 mm<sup>2</sup> [AWG18] or greater is recommended for easy handling.

CVVS, MVVS: PVC insulated PVC jacketed shielded control cable  
 CPEVS: PE insulated PVC jacketed shielded communication cable  
 CVV: PV insulated PVC sheathed control cable

2-3. System configuration restrictions

2-3-1. Common restrictions for the CITY MULTI system

For each Heat source unit, the maximum connectable quantity of Indoor unit is specified at its Specifications table.

- A) 1 Group of Indoor units can have 1-16 Indoor units;
- B) Maximum 2 remote controllers for 1 Group;  
\*MA/ME remote controllers cannot be present together in 1group.  
\*To wire PAC-YT53CRAU, use a wire with a diameter of 0.3 mm<sup>2</sup> [AWG22]
- C) 1 LOSSNAY unit can interlock maximum 16 Indoor units; 1 Indoor unit can interlock only 1 LOSSNAY unit.
- D) Maximum 3 System controllers are connectable when connecting to TB3 of the Heat source unit.
- E) Maximum 6 System controllers are connectable when connecting to TB7 of the Heat source unit, if the transmission power is supplied by the Heat source unit.
- F) 4 System controllers or more are connectable when connecting to TB7 of the Heat source unit, if the transmission power is supplied by the power supply unit PAC-SC51KUA. Details refer to 2-3-3-C.  
\*System controller connected as described in D) and E) would have a risk that the failure of connected Heat source unit would stop power supply to the System controller

2-3-2. Ensuring proper communication power for M-NET

In order to ensure proper communication among Heat source unit, Indoor unit, LOSSNAY and Controllers, the transmission power situation for the M-NET should be observed. In some cases, Transmission booster should be used. Taking the power consumption index of Indoor unit sized P06-P54 as 1, the equivalent power consumption index and supply capability index of others are listed at Table 2-3-1 and Table 2-3-2.

Table 2-3-1 The equivalent power consumption

Indoor unit			LOSSNAY	BC controller	PWFY			MA RC.	ME Remote controller/Adapter	
Sized P06-P54	Sized P72, 96	PEFY-AF1200 CFMR	LGH-RX-E	CMB	P36NMU-E-BU	P36NMU-E-AU	P72NMU-E-AU	PAC-YT53CRAU PAR-FA32MA PZ-41SLB PZ-60DR-E	PZ-52SF PAC-YG60MCA PAC-YG66DCA PAC-YG63MCA	PAR-U01MEDU PAC-IF01AHC-J
1	7	2	0	2	6	1	5	0	1/4	1/2

Centralized Remote controller				ON/OFF controller	MN Converter		M-NET Interface/Converter	Heat source unit
AG-150A-A EB-50GU-A	TC-24B	GB-24A	LMAP04U-E BAC-HD150	PAC-YT40ANRA	CMS-MNF-B	CMS-MNG-E	MAC-333 PAC-SF83MA-E	TB7 power consumption
1/2	4	3	0	1	1/2	2	0	0

\*RC: Remote Controller

Table 2-3-2 The equivalent power supply

Transmission Booster	Power supply unit	Expansion controller	BM ADAPTER	System Controller	Heat source unit	Heat source unit
PAC-SF46EPA	PAC-SC51KUA	PAC-YG50ECA	BAC-HD150	GB-50ADA-A	Connector TB3 and TB7 total *	Connector TB7 only
25	5	6	6	6	32	6

\*If PAC-SC51KUA is used to supply power at TB7 side, no power supply need from Heat source unit at TB7, Connector TB3 itself will therefore have 32.

With the equivalent power consumption values in Table 2-3-1 and Table 2-3-2, PAC-SF46EPA can be designed into the air-conditioner system to ensure proper system communication according to 2-3-2-A, B, C.

2-3-2-A) Firstly, count from TB3 at TB3 side the total quantity of Indoor units, ME remote controller, and System controllers.

If the total quantity reaches 40, a PAC-SF46EPA should be set. In this case, Indoor units sized P72 and 96 are counted as 2 indoor units, but MA remote controller(s) and PZ-41SLB are NOT counted.

2-3-2-B) Secondly, count from TB7 side to TB3 side the total transmission power consumption index. If the total power consumption reaches 32, a PAC-SF46EPA should be set. Yet, if a PAC-SC51KUA or another controller with a built-in power supply, such as PAC-YG50ECA, is used to supply power at TB7 side, count from index TB3 side only.

2-3-2-C) Thirdly, count from TB7 at TB7 side the total transmission power consumption index, If the total power consumption reaches 6, a PAC-SF46EPA should be set.

■ System example

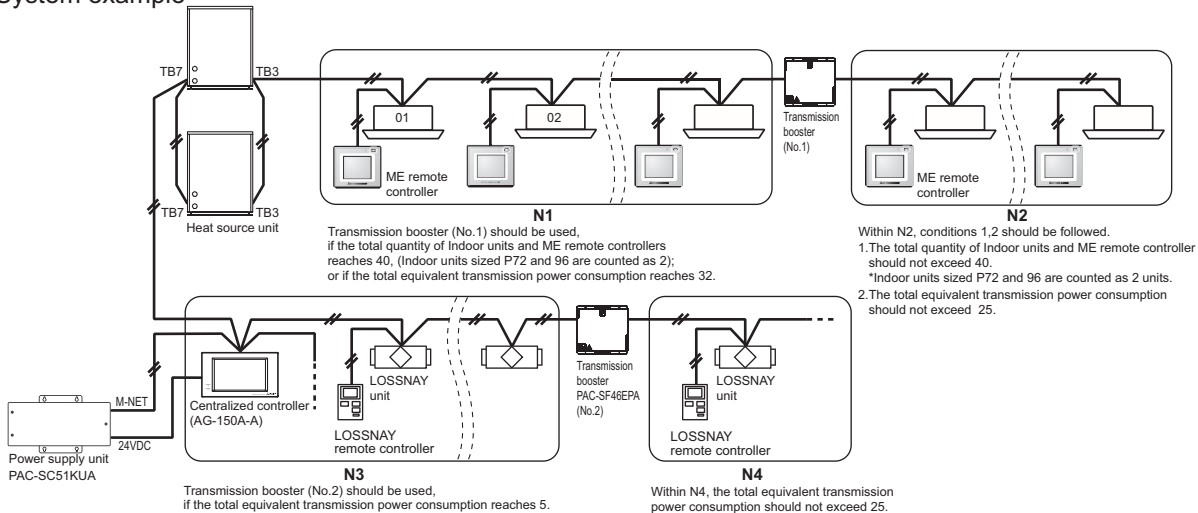

2-3-3. Ensuring proper power supply to System controller

The power to System controller (excluding LM-AP) is supplied via M-NET transmission line. M-NET transmission line at TB7 side is called Central control transmission line while one at TB3 side is called Indoor-Heat source transmission line. There are 3 ways to supply power to the System controller .

- A) Connecting to TB3 of the Heat source unit and receiving power from the Heat source unit.
- B) Connecting to TB7 of the Heat source unit and receiving power from the Heat source unit.
- C) Connecting to TB7 of the Heat source unit but receiving power from power supply unit PAC-SC51KUA.

2-3-3-A. When connecting to TB3 of the Heat source unit and receiving power from the Heat source unit.

Maximum 3 System controllers can be connected to TB3. If there is more than 1 Heat source unit, it is necessary to replace power supply switch connector CN41 with CN40 on one Heat source unit.

Fig. 2-3-3-A

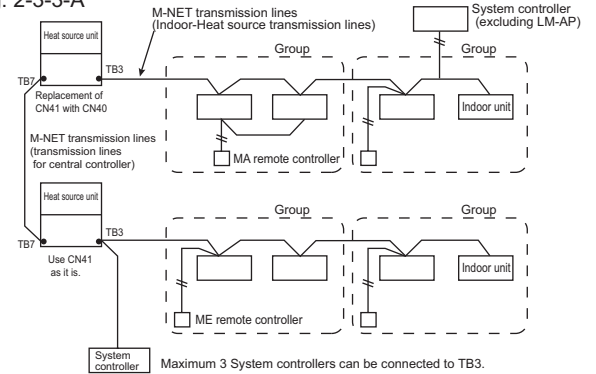

2-3-3-B. When connecting to TB7 of the Heat source unit and receiving power from the Heat source unit.

Maximum 6 System controllers can be connected to TB7 and receiving power from the Heat source unit. It is necessary to replace power supply switch connector CN41 with CN40 on one Heat source unit.

Fig. 2-3-3-B

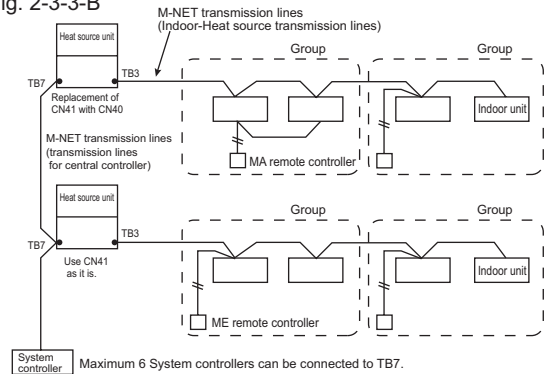

2-3-3-C. When connecting to TB7 of the Heat source unit but receiving power from PAC-SC51KUA.

When using PAC-SC51KUA to supply transmission power, the power supply connector CN41 on the Heat source units should be kept as it is. It is also a factory setting.

1 PAC-SC51KUA supports maximum 1 AG-150A-A or 1 EB-50GU-A unit due to the limited power DC 24V at its TB3.

However, 1 PAC-SC51KUA supplies transmission power at its TB2 equal to 5 Indoor units, which is referable at Table 2-3-2.

If PZ-52SF, System controller, ON/OFF controller connected to TB7 consume transmission power more than 5 (Indoor units), Transmission booster PAC-SF46EPA is needed. PAC-SF46EPA supplies transmission power equal to 25 Indoor units.

Fig. 2-3-3-D

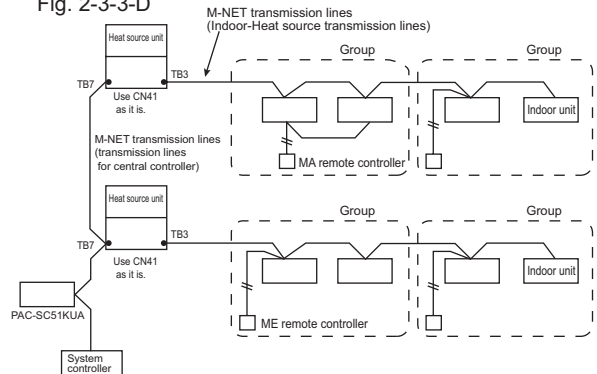

**CAUTION**

AG-150A-A/EB-50GU-A\*1 are recommended to connect to TB7 because it performs back-up to a number of data.

In an air conditioner system has more than 1 Heat source units, AG-150A-A/EB-50GU-A receiving transmission power at TB3 or TB7 on one of the Heat source units would have a risk that the connected Heat source unit failure would stop power supply to AG-150A-A/EB-50GU-A, and disrupt the whole system. When applying apportioned electric power function, AG-150A-A/EB-50GU-A are necessary to connected to TB7 and has its own power supply unit PAC-SC51KUA.

Note: Power supply unit PAC-SC51KUA is for AG-150A-A/EB-50GU-A.

\*1: AG-150A-A is an example model of system controllers.

S.D. WR2

### 2-3-4. Power supply to LM-AP

1-phase 208-230V AC power supply is needed.

The power supply unit PAC-SC51KUA is not necessary when connecting only the LM-AP. Yet, make sure to change the power supply changeover connector CN41 to CN40 on the LM-AP.

### 2-3-5. Power supply to expansion controller

1-phase 100-240VAC power supply is needed.

The power supply unit PAC-SC51KUA is not necessary.

The expansion controller supplies power through TB3, which equals 6 indoor units. (refer to Table 2-3-2)

### 2-3-6. Power supply to BM ADAPTER

1-phase 100-240VAC power supply is needed.

The power supply unit PAC-SC51KUA is not necessary when only BM ADAPTER is connected.

Yet, make sure to move the power jumper from CN41 to CN40 on the BM ADAPTER.

### 2-3-7. Power supply to GB-50ADA-A

1-phase 100-240VAC power supply is needed.

The power supply unit PAC-SC51KUA is not necessary.

GB-50ADA-A supplies power through TB3, which equals 6 indoor units. (refer to Table 2-3-2)

2-4. Address setting

2-4-1. Switch operation

In order to constitute CITY MULTI in a complete system, switch operation for setting the unit address No. and connection No. is required.

- ① Address No. of heat source unit, indoor unit and ME remote controller.  
The address No. is set at the address setting board.  
In the case of WR2 system, it is necessary to set the same No. at the branch No. switch of indoor unit as that of the BC controller connected. (When connecting two or more branches, use the lowest branch No.)

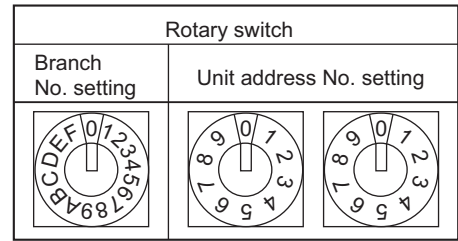

② Caution for switch operations

- Be sure to shut off power source before switch setting. If operated with power source on, switch can not operate properly.
- No units with identical unit address shall exist in one whole air conditioner system. If set erroneously, the system can not operate.

③ MA remote controller

- When connecting only one remote controller to one group, it is always the main remote controller. When connecting two remote controllers to one group, set one remote controller as the main remote controller and the other as the sub remote controller.
- The factory setting is "Main".

PAC-YT53CRAU



























Setting the dip switches

There are switches on the back of the top case. Remote controller Main/Sub and other function settings are performed using these switches. Ordinarily, only change the Main/Sub setting of SW1. (The factory settings are ON for SW1, 3, and 4 and OFF for SW2.)

SW No	SW contents Main	ON	OFF	Comment
1	Remote controller Main/Sub setting	Main	Sub	Set one of the two remote controllers at one group to "ON".
2	Temperature display units setting	Celsius	Fahrenheit	When the temperature is displayed in [Fahrenheit], set to "OFF".
3	Cooling/heating display in AUTO mode	Yes	No	When you do not want to display "Cooling" and "Heating" in the AUTO mode, set to "OFF".
4	Indoor temperature display	Yes	No	When you do not want to display the indoor temperature, set to "OFF".



2-4-2. Rule of setting address

Unit	Address setting	Example	Note	
Indoor unit	01 ~ 50	 	Use the most recent address within the same group of indoor units. Make the indoor units address connected to the BC controller (Sub) larger than the indoor units address connected to the BC controller (Main). If applicable, set the sub BC controllers in an PQR system in the following order: (1) Indoor unit to be connected to the BC controller (Main) (2) Indoor unit to be connected to the BC controller (No.1 Sub) (3) Indoor unit to be connected to the BC controller (No.2 Sub) Set the address so that (1)<(2)<(3)	
Heat source unit	51 ~ 99, 100 (Note1)	 	The smallest address of indoor unit in same refrigerant system + 50 Assign sequential address numbers to the heat source units in one refrigerant circuit system. OC and OS are automatically detected. (Note 2) * Please reset one of them to an address between 51 and 99 when two addresses overlap. * The address automatically becomes "100" if it is set as "01~ 50"	
BC controller (Main)	52 ~ 99, 100	 	The address of heat source unit + 1 * Please reset one of them to an address between 51 and 99 when two addresses overlap. * The address automatically becomes "100" if it is set as "01~ 50"	
BC controller (Sub)	52 ~ 99, 100	 	Lowest address within the indoor units connected to the BC controller (Sub) plus 50.	
Local remote controller	ME, LOSSNAY Remote controller (Main)	101 ~ 150 <b>1</b> Fixed	 	The smallest address of indoor unit in the group + 100 * The place of "100" is fixed to "1"
	ME, LOSSNAY Remote controller (Sub)	151 ~ 199, 200 <b>1</b> Fixed	 	The address of main remote controller + 50 * The address automatically becomes "200" if it is set as "00"
System controller	ON/OFF remote controller	000, 201 ~ 250   	The smallest group No. to be managed + 200 * The smallest group No. to be managed is changeable.	
	AG-150A-A GB-50ADA-A GB-24A EB-50GU-A	000, 201 ~ 250   		
	PAC-YG50ECA	000, 201 ~ 250   	* Settings are made on the initial screen of AG-150A-A.	
	BAC-HD150	000, 201 ~ 250   	* Settings are made with setting tool of BM ADAPTER.	
	LMAP04U-E	201 ~ 250 <b>2</b> Fixed	 	

Note1: To set the address to "100", set it to "50"

Note2: Heat source units OC and OS in one refrigerant circuit system are automatically detected.  
OC and OS are ranked in descending order of capacity. If units are the same capacity, they are ranked in ascending order of their address.

S.D. WR2



2-4-3. System examples

Factory setting

Original switch setting of the heat sources, indoors, controllers, LM-AP, and BM ADAPTER at shipment is as follows.

- Heat source unit : Address: 00, CN41: ON (Jumper), DipSW2-1: OFF
- Indoor unit : Address: 00
- BC controller : Address: 00
- ME remote controller : Address: 101
- LM-AP : Address: 247, CN41: ON (Jumper), DipSW1-2: OFF
- BM ADAPTER : Address: 000, CN41: ON (Jumper)

Setting at the site

- DipSW2-1(Heat source) : When the System Controller is used, all the Dip SW2-1 at the heat source units should be set to "ON". \* Dip SW2-1 remains OFF when only LM-AP is used.
- DipSW1-2(LM-AP) : When the LM-AP is used together with System Controller, DipSW1-2 at the LM-AP should be set to "ON".
- CN40/CN41 : Change jumper from CN41 to CN 40 at heat source control board will activate central transmission power supply to TB7;  
(Change jumper at only one heat source unit when activating the transmission power supply without using a power supply unit.)  
Change jumper from CN41 to CN 40 at LM-AP will activate transmission power supply to LM-AP itself;  
Power supply unit is recommended to use for a system having more than 1 heat source unit, because the central transmission power supply from TB7 of one of heat source units is risking that the heat source unit failure may let down the whole central control system.

2-4-3-1. MA remote controller, Single-refrigerant-system, No System Controller

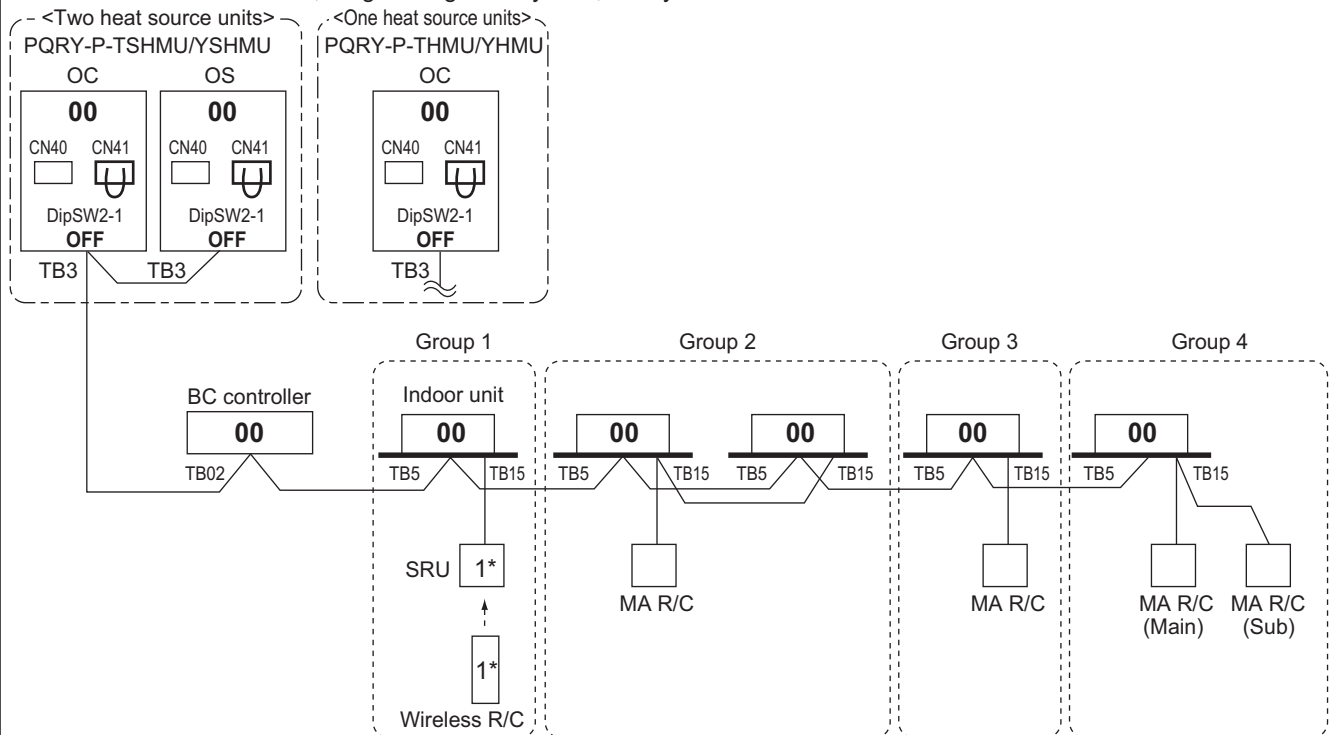

\*1 For Wireless R/C and Signal receiver unit (SRU), channel 1, 2 and 3 are selectable and should be set to same channel!

NOTE:

1. Heat source units OC and OS in one refrigerant circuit system are automatically detected. OC and OS are ranked in descending order of capacity. If units are the same capacity, they are ranked in ascending order of their address.
2. No address setting is needed.
3. For a system having more than 32 indoor unit (P06-P54), confirm the need of Booster at 2-3 "System configuration restrictions".
4. Indoor units should be set with a branch number.
5. Address setting is required if a sub BC controller is connected.

2-4-3-2. MA remote controller, Single-refrigerant-system, System Controller

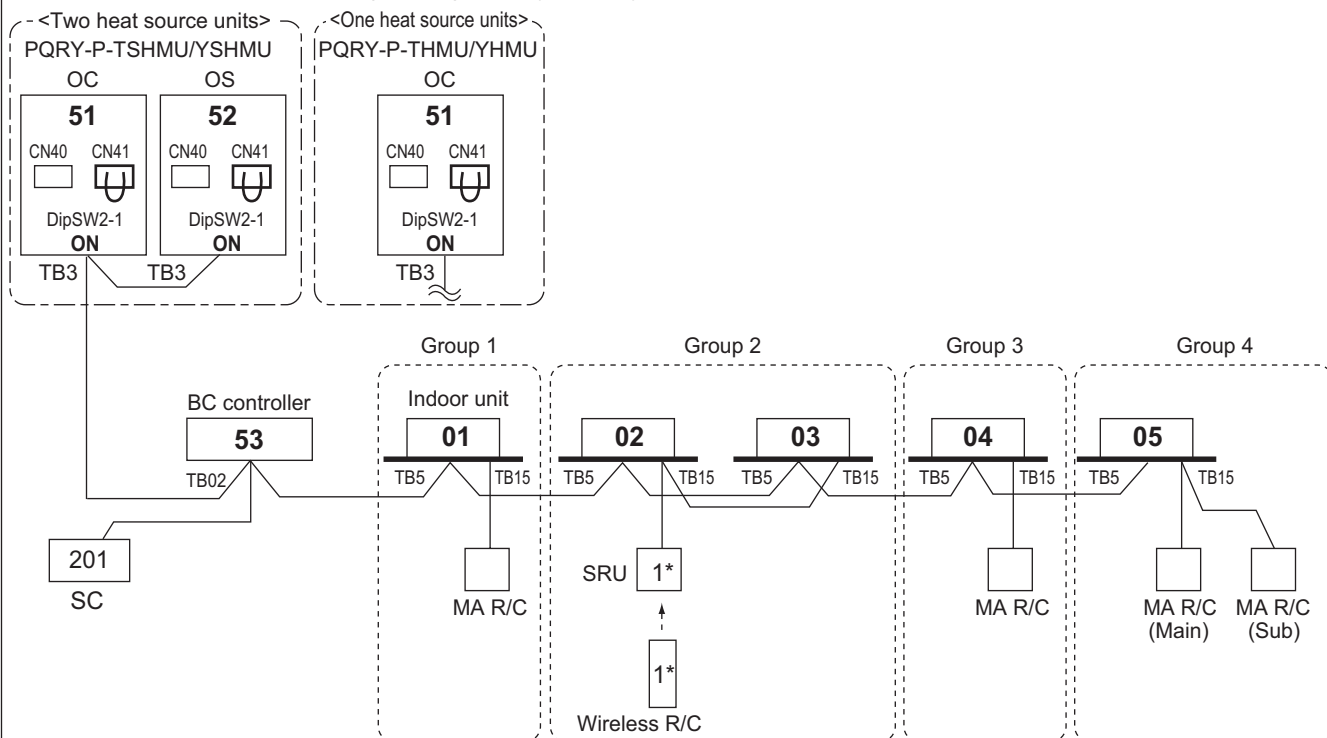

\*1 For Wireless R/C and Signal receiver unit (SRU), channel 1, 2 and 3 are selectable and should be set to same channel`

\*SC can be connected to TB3 side or TB7 side;  
Should SC connected to TB7 side, change Jumper from CN41 to CN40 at the Heat source unit module so as to supply power to the SC.

NOTE:

1. Heat source units OC and OS in one refrigerant circuit system are automatically detected.  
OC and OS are ranked in descending order of capacity. If units are the same capacity, they are ranked in ascending order of their address.
2. Address should be set to Indoor units and central controller.
3. For a system having more than 32 indoor unit (P06-P54), confirm the need of Booster at 2-3 "System configuration restrictions".
4. Indoor units should be set with a branch number.

S.D. WR2

2-4-3-3. MA remote controller, Multi-refrigerant-system, System Controller at TB7/TB3 side, Booster for long M-NET wiring

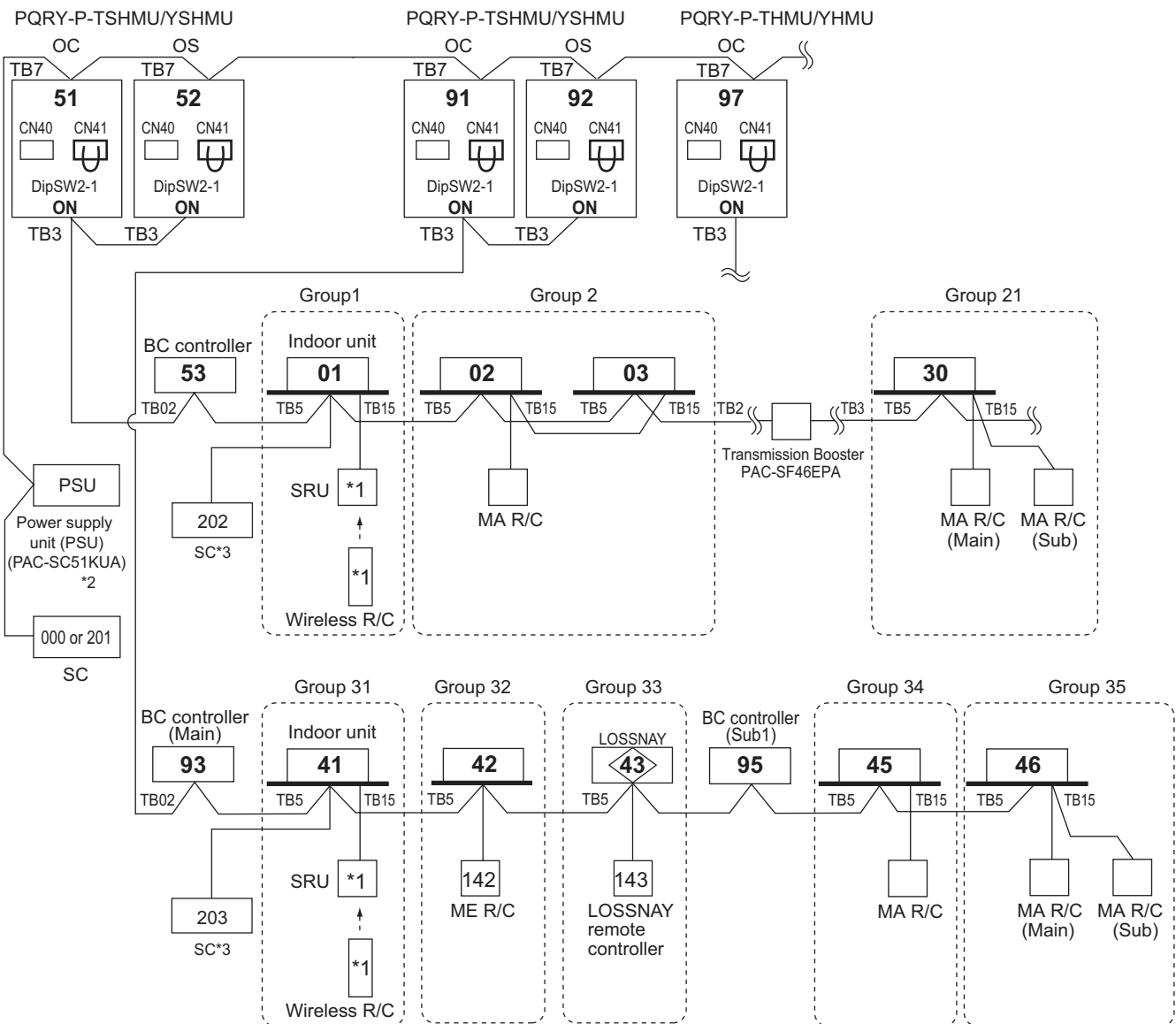

- \*1 For Wireless R/C and Signal receiver unit (SRU), channel 1, 2 and 3 are selectable and should be set to same channel.
- \*2 System controller should connect to TB7 at the Heat source unit and use power supply unit together in Multi-Refrigerant-System. For AG-150A-A, 24VDC should be used with the PAC-SC51KUA.
- \*3 When multiple system controllers are connected in the system, set the controller with more functions than others as a "main" controller and others as "sub". TC-24A, AG-150A-A, GB-50ADA-A and GB-24A are for exclusive use as a "main" system controller and cannot be used as a "sub" system controller. Make the setting to only one of the system controllers for "prohibition of operation from local remote controller".

NOTE:

1. Heat source units OC and OS in one refrigerant circuit system are automatically detected. OC and OS are ranked in descending order of capacity. If units are the same capacity, they are ranked in ascending order of their address.
2. Address should be set to Indoor units, LOSSNAY and system controller.
3. M-NET power is supplied by the Heat source unit at TB3, while Indoor unit and ME remote controller consume the M-NET power for transmission use. The power balance is needed to consider for long M-NET wiring. Details refer to 2-3 "System configuration restrictions".
4. Indoor units should be set with a branch number.
5. Assign an address to each of the sub BC controllers which equals the sum of the smallest address of the indoor units that are connected to each sub BC controller and 50.

S.D. WR2

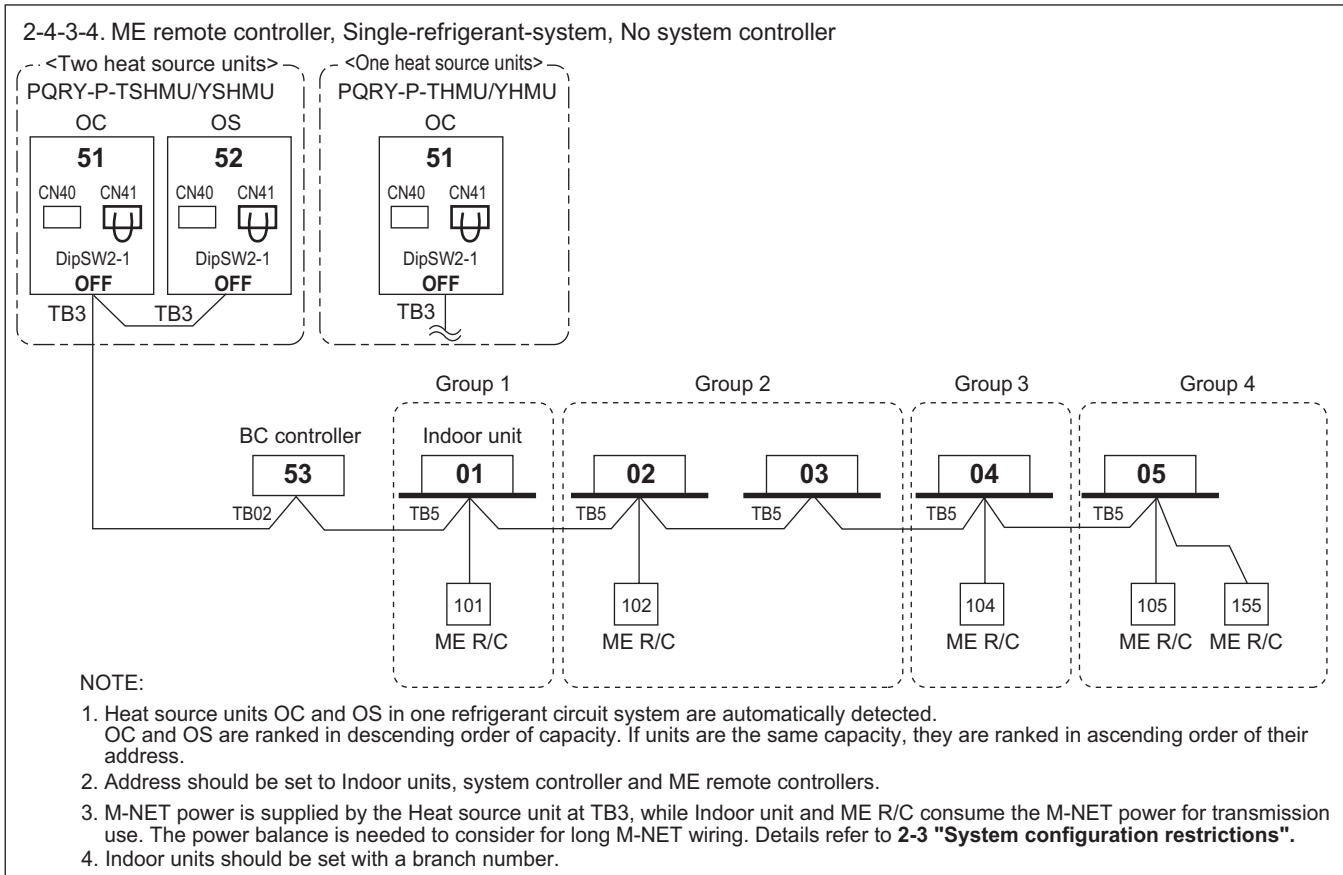

S.D. WR2

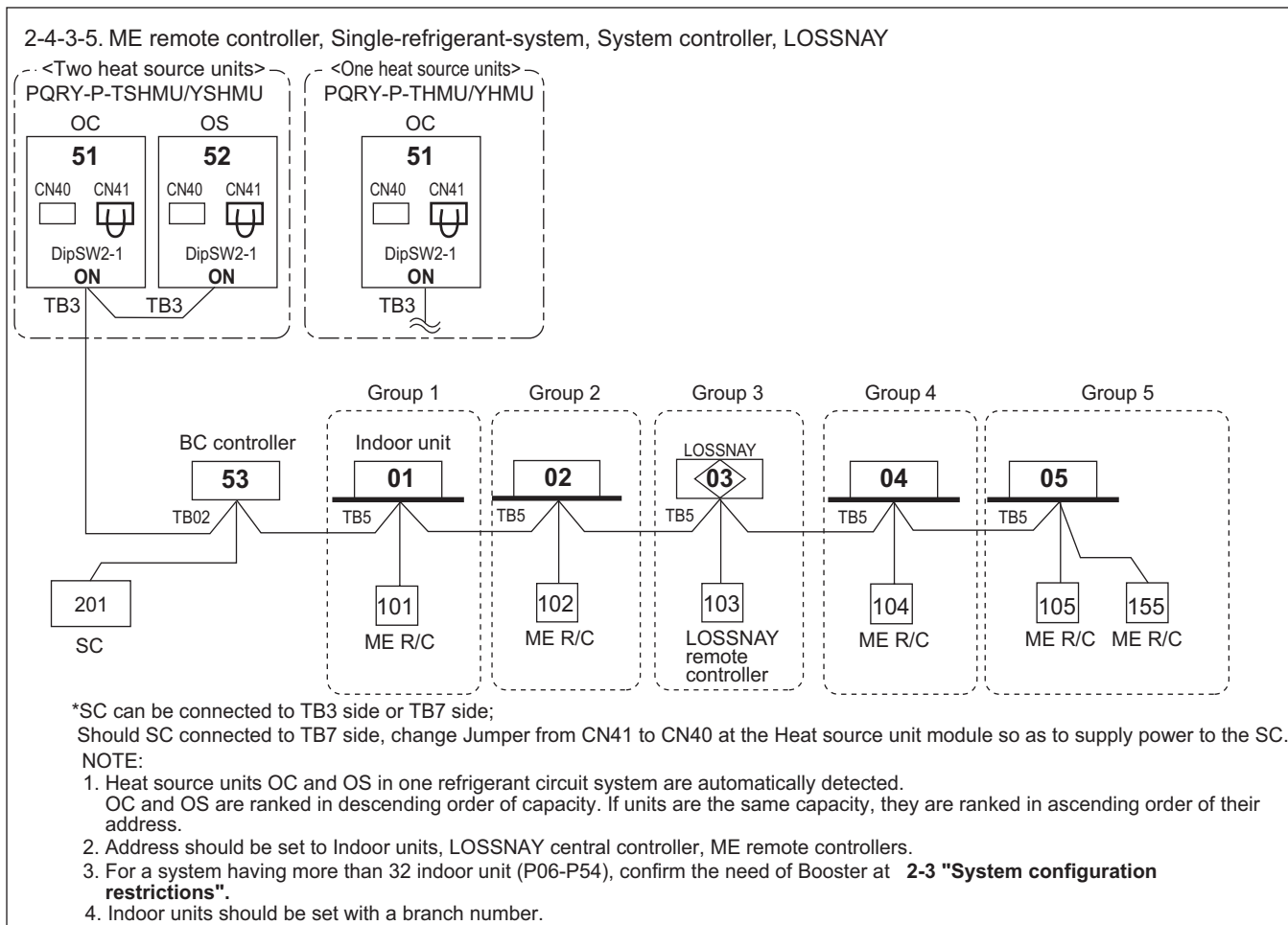

2-4-3-6. ME remote controller, Multi-refrigerant-system, System Controller at TB 7side, LOSSNAY, Booster for long M-NET wiring

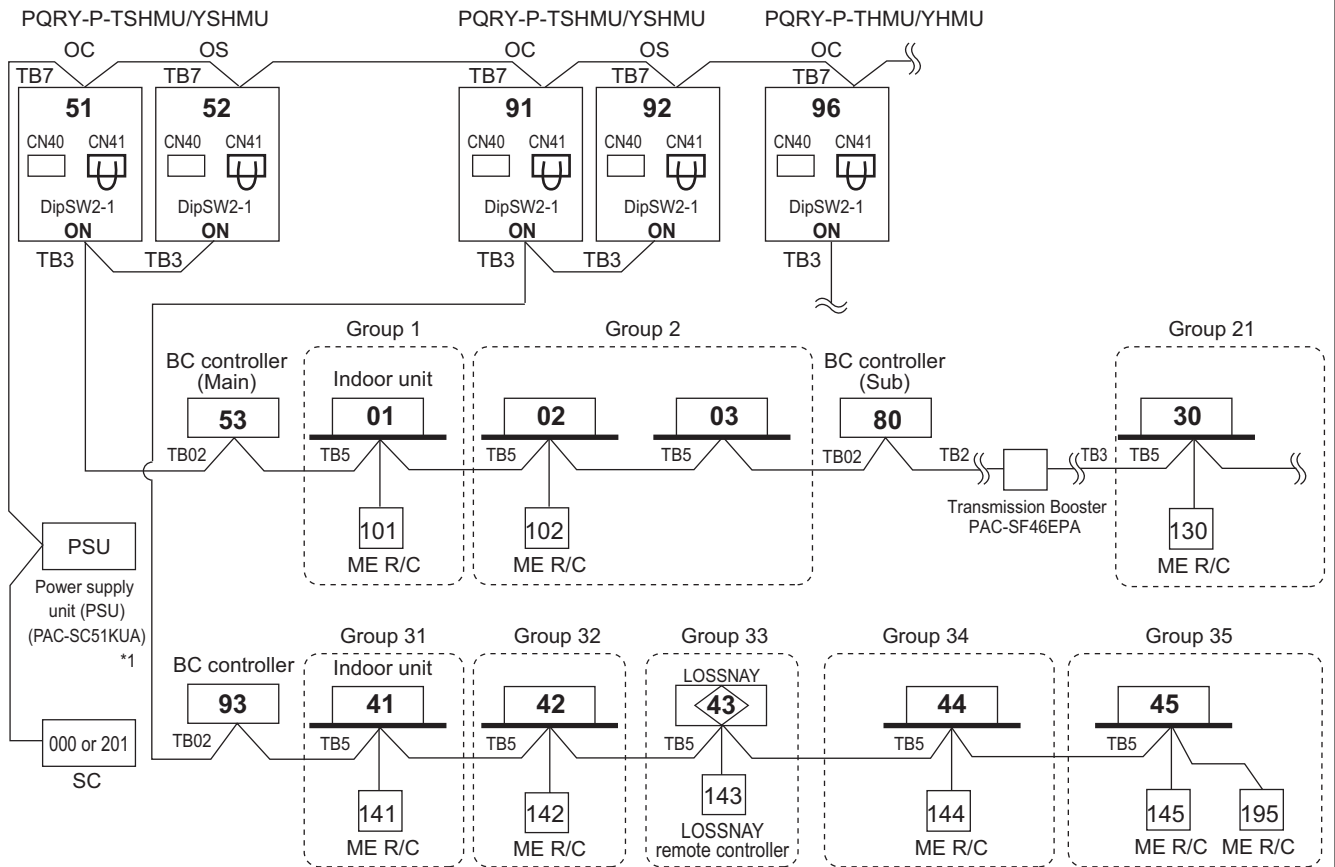

\*1 System controller should connect to TB7 at the Heat source unit and use power supply unit together in Multi-Refrigerant-System. For AG-150A-A, 24VDC should be used with the PAC-SC51KUA.

NOTE:

- Heat source units OC and OS in one refrigerant circuit system are automatically detected. OC and OS are ranked in descending order of capacity. If units are the same capacity, they are ranked in ascending order of their address.
- M-NET power is supplied by the Heat source unit at TB3, while Indoor unit and ME R/C consume the M-NET power for transmission use. The power balance is needed to consider for long M-NET wiring. Details refer to 2-3 "System configuration restrictions".
- Indoor units should be set with a branch number.
- Assign an address to each of the sub BC controllers which equals the sum of the smallest address of the indoor units that are connected to each sub BC controller and 50. When the address assigned to sub BC controller overlaps those of any other units including heat source units (OC/OS) or main BC controller, sub BC controller will be given priority to have the address.

2-4-3-7. Example : BC, BC sub

NOTE

- Indoor units should be set with a branch number.
- BC (main) address = O/U address + 1
- BC (sub) address = Lowest address within the indoor units connected to the BC controller (sub) + 50
- If applicable, set the sub BC controllers in an PQR system in the following order:
  - Indoor unit to be connected to the BC controller (Main)
  - Indoor unit to be connected to the BC controller (No.1 Sub)
  - Indoor unit to be connected to the BC controller (No.2 Sub)
 Set the address so that (1)<(2)<(3)

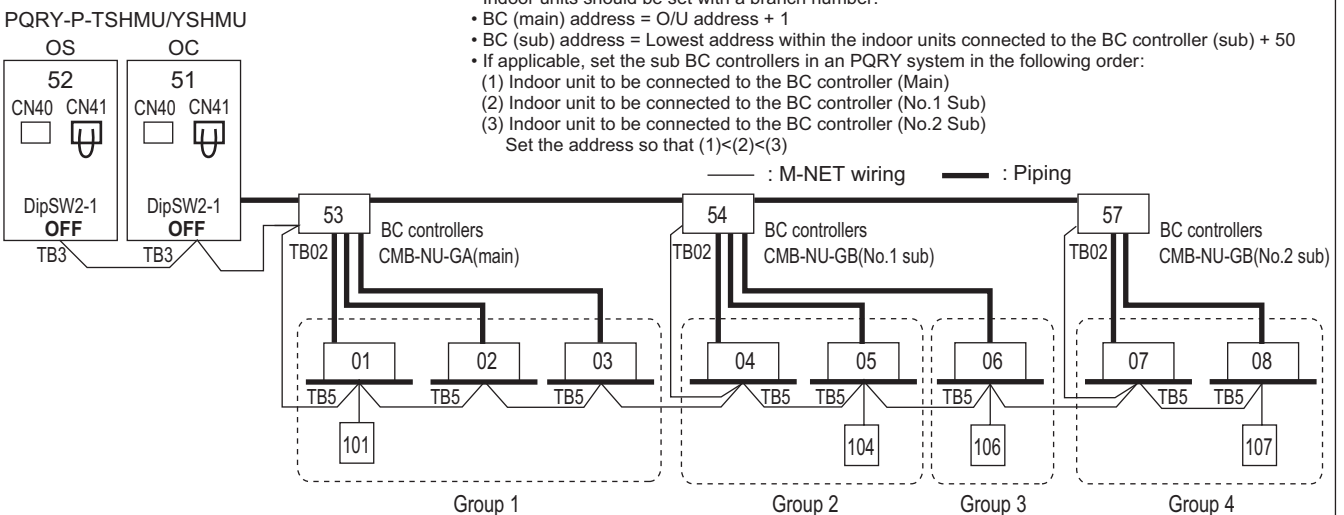

S.D. WR2

2-4-3-8. TG-2000A(\*1)+AG-150A-A\*2,GB-50ADA-A

AG-150A-A can control max. 50 indoor units;  
 GB-50ADA-A can control max. 50 indoor units;  
 TG-2000A can control max. 40 of AG-150A-A and GB-50ADA-A;\*3  
 TG-2000A can control max. 2000 indoor units.

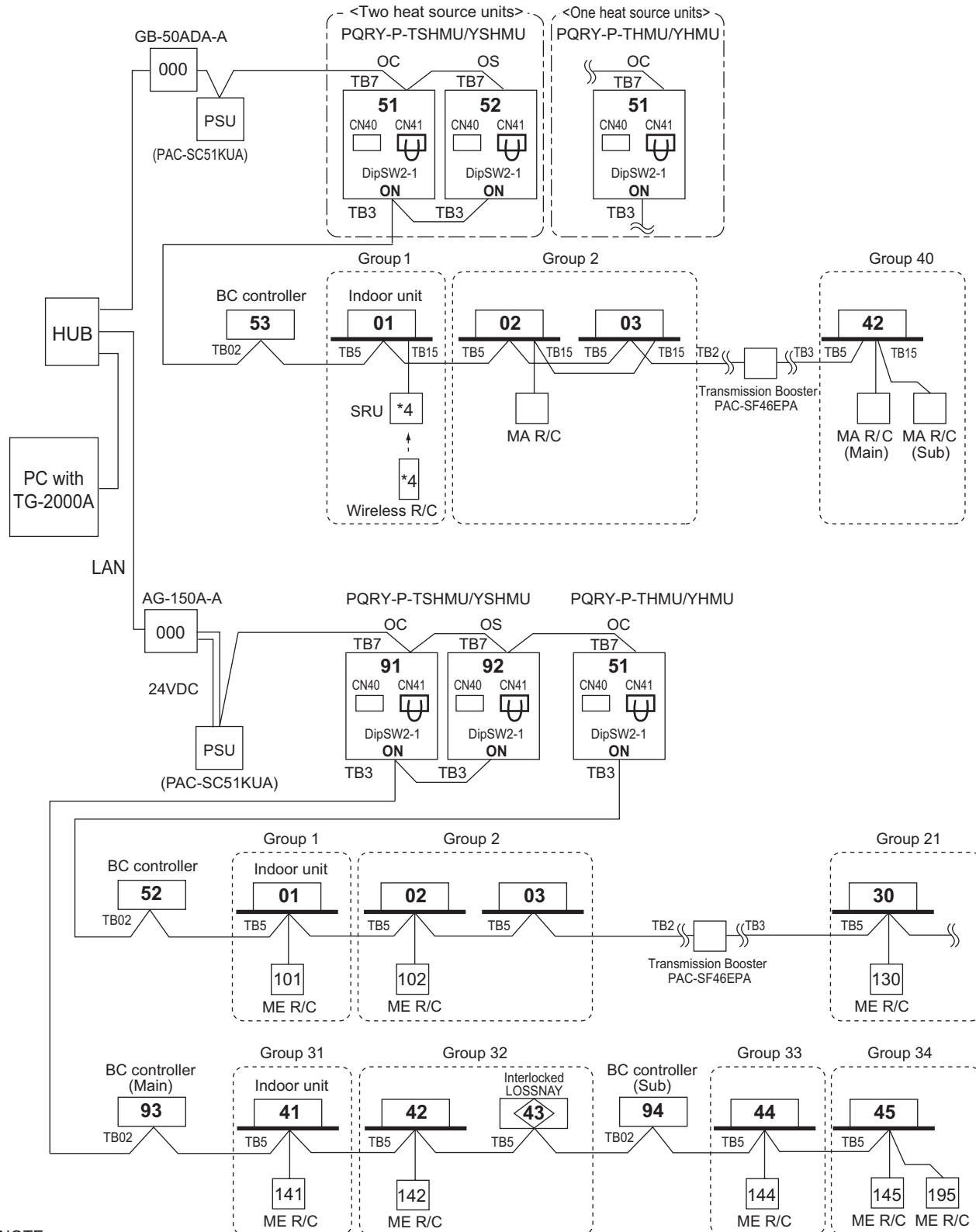

NOTE

- \*1 TG-2000A (Ver.5.5 or later) supports AG-150A-A (Ver.1 series).  
 TG-2000A (Ver. 6.1 or later) supports AG-150A-A (Ver. 2.1 or later) connected with the expansion controller (EC).  
 TG-2000A (Ver. 6.3 or later) supports GB-50ADA-A.
- \*2 AG-150A-A (Ver.1 series) does not support the expansion controller (EC).
- \*3 When AG-150A-A connected with the expansion controller (EC) is connected, the number of EC will be the maximum controllable number.  
 TG-2000A can control up to 40 EC or AG-150A-A without EC connection.
- \*4 For Wireless R/C and Signal receiver unit (SRU), channel 1, 2 and 3 are selectable and should be set to same channel.

2-4-3-9. AG-150A-A + PAC-YG50ECA (Expansion Controller)

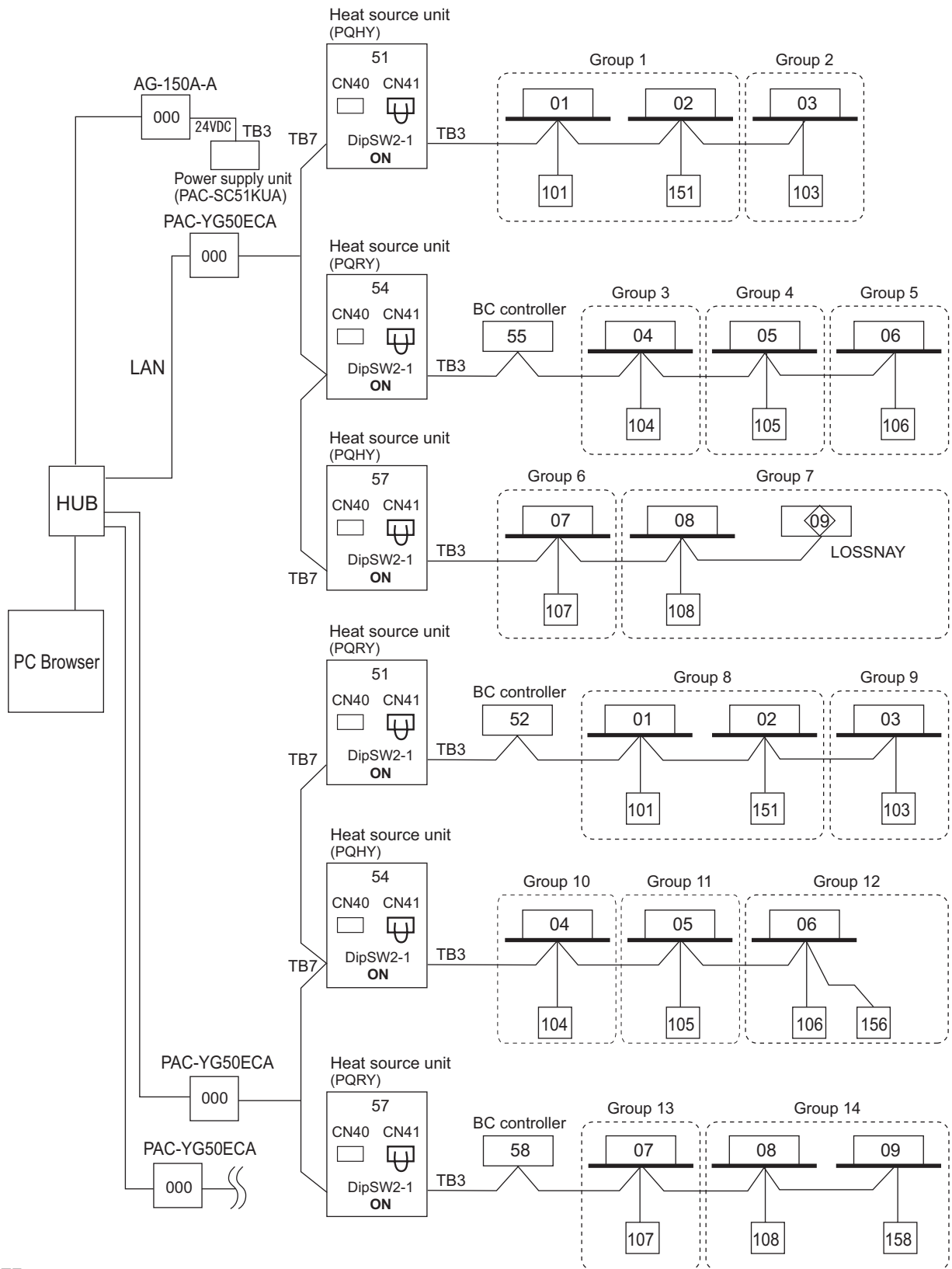

NOTE

- AG-150A-A\*1 can control maximum 150 indoor units via expansion controller.
- When connecting AG-150A-A to PAC-YG50ECA, TB2 for power supply unit does not need to be connected to AG-150A-A.
- \*1 AG-150A-A (Ver. 2.1 or later) supports the expansion controller.

S.D. WR2

2-4-3-10. LM-AP

LM-AP can transmit for max. 50 indoor units;

If system controller (SC) is used, DipSW1-2 at LM-AP and DipSW2-1 at Heat source unit should set to "ON".

Change Jumper from CN41 to CN40 to activate power supply to LM-AP itself for those LM-AP connected without system controller (SC).

LM-AP can transmit for max. 50 indoor units in single-refrigerant-system or multi-refrigerant-system.  
LM-AP(01) identified by Neuron ID

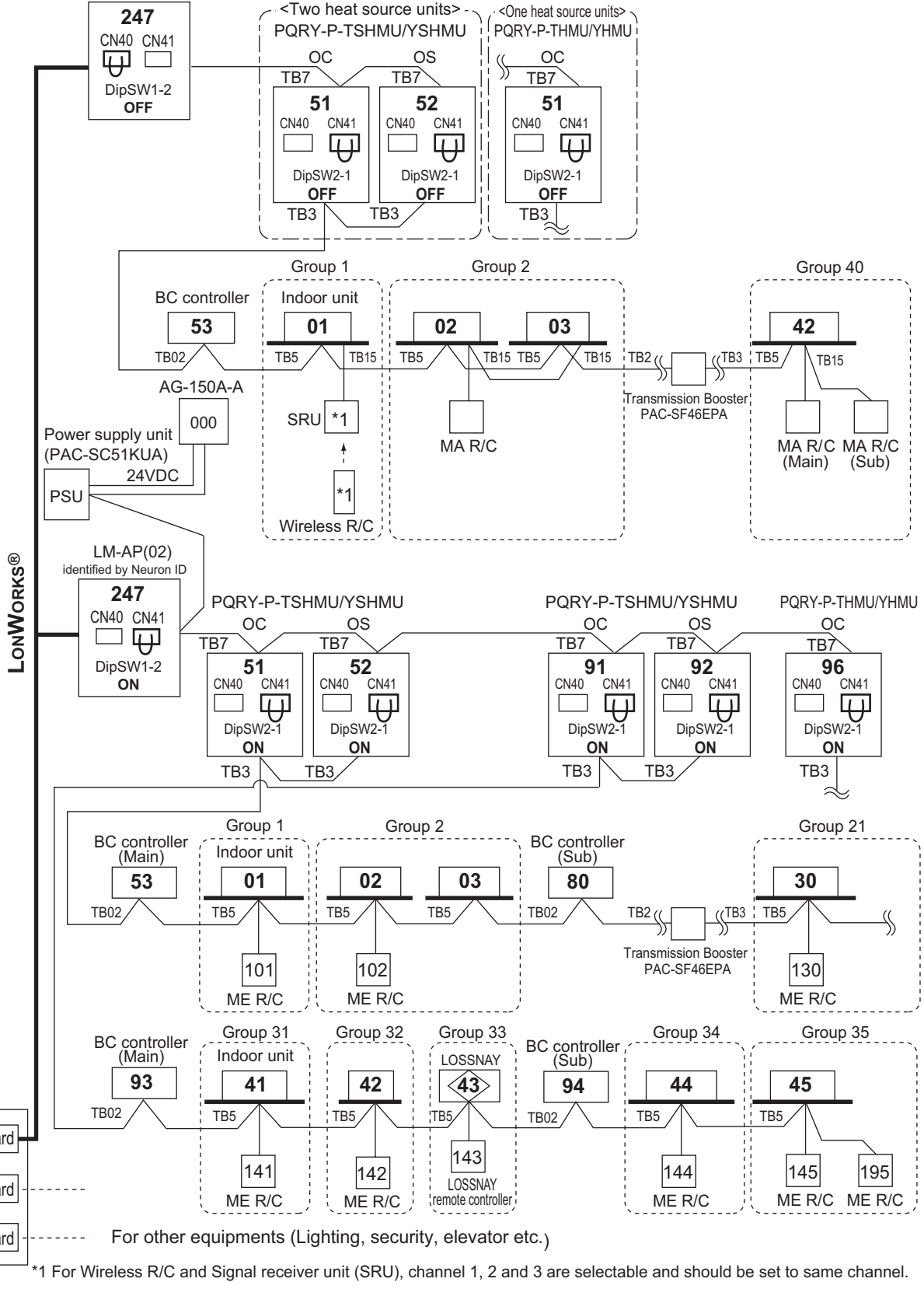

S.D. WR2



2-4-3-11. BM ADAPTER

BM ADAPTER can transmit for max. 50 indoor units;

Change Jumper from CN41 to CN40 to activate power supply to BM ADAPTER itself for those BM ADAPTER connected without the power supply unit.

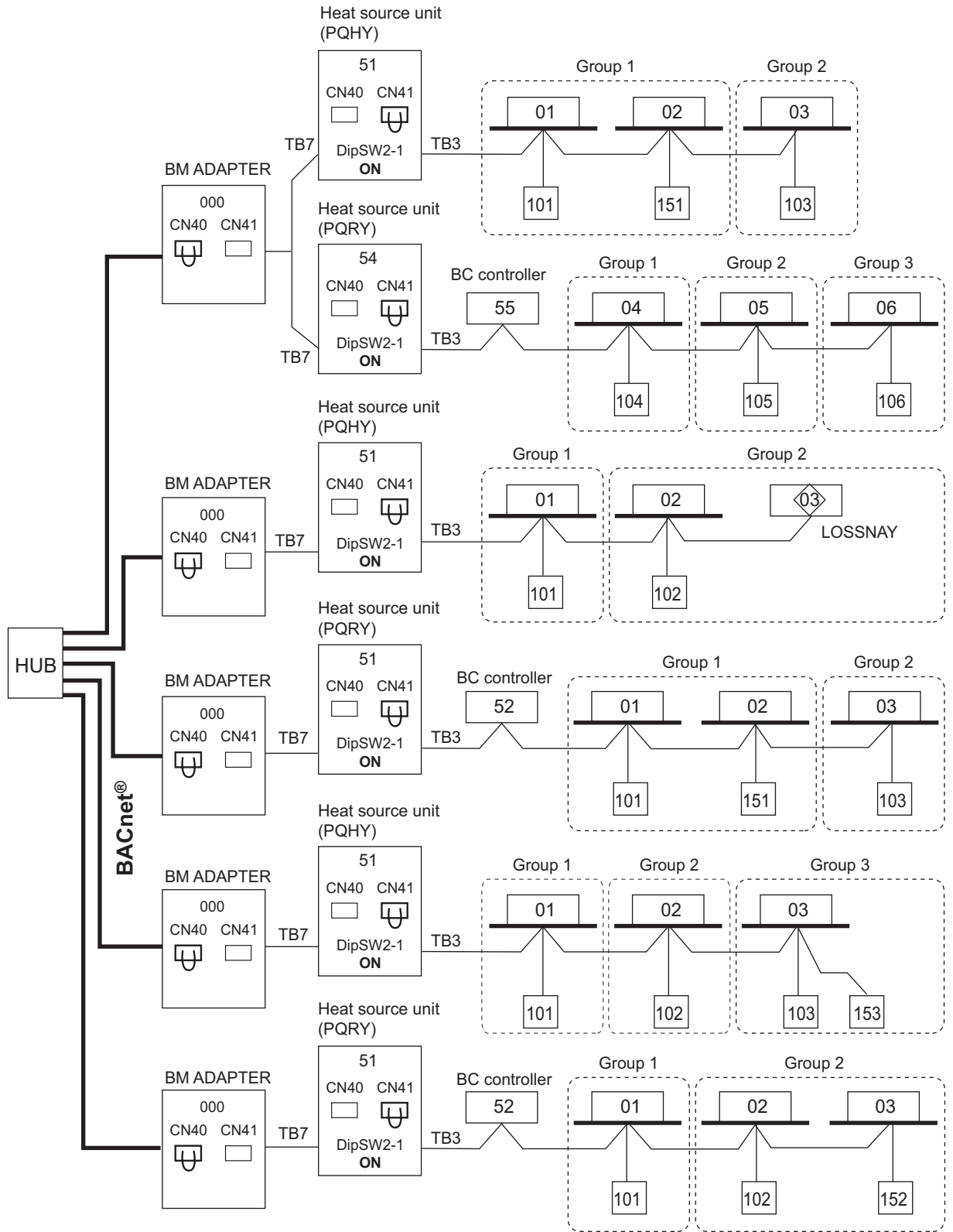

S.D. WR2

2-4-3-12. BM ADAPTER

BM ADAPTER(\*1) can transmit for max. 150 indoor units/via expansion controllers (PAC-YG50ECA).  
 When the dual-set-point function is used, no expansion controllers can be connected, and only up to 50 units can be controlled from each BAC-HD150.

BM ADAPTER can transmit for max. 50 indoor units in single-refrigerant-system or multi-refrigerant-system.

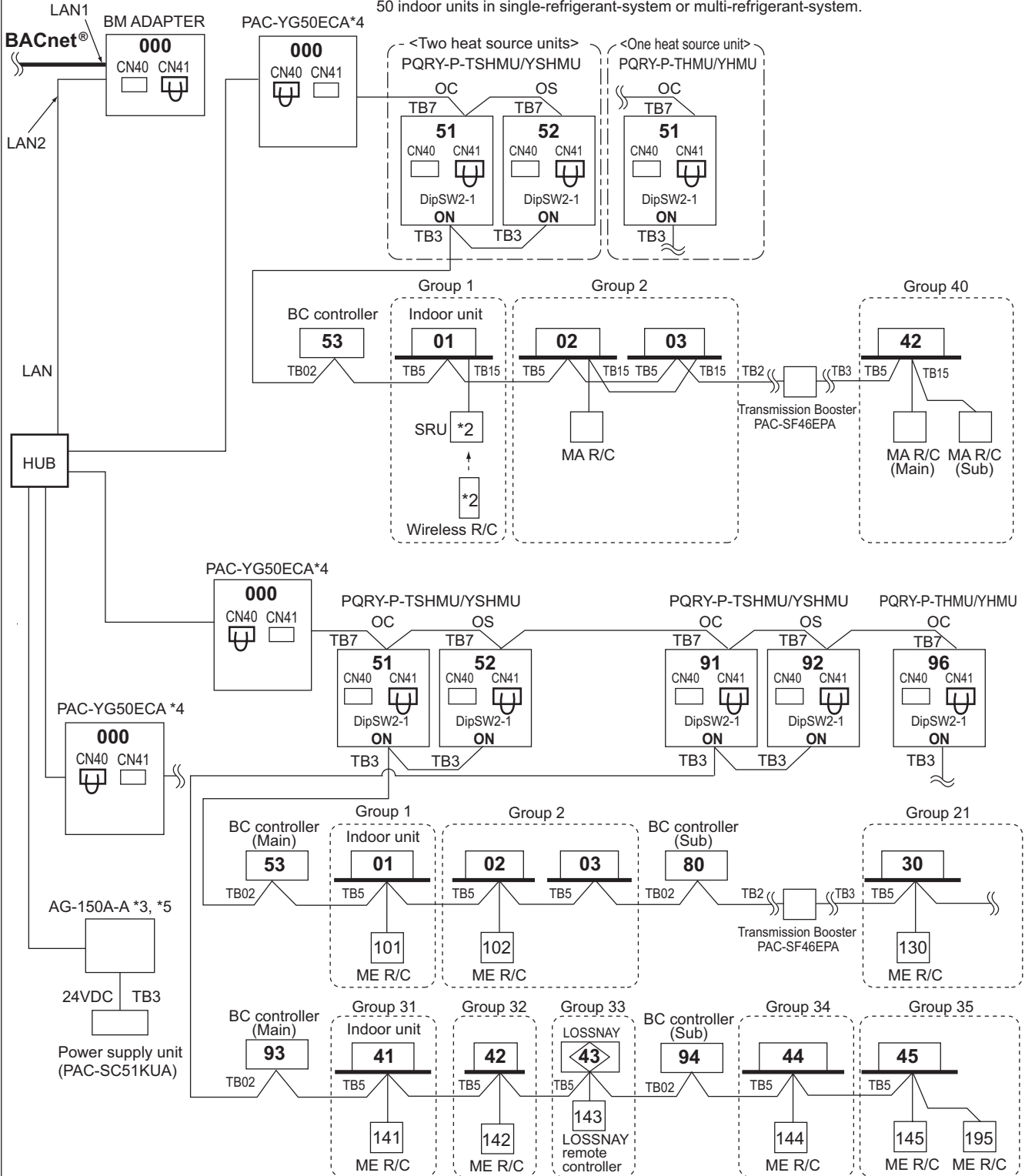

NOTE

• It is not necessary to connect the M-NET transmission line to the TB3 on BM ADAPTER. Leave the power jumper of BM ADAPTER connected to CN41.

\*1 BM ADAPTER (Ver.2.00 or later) supports the expansion controller.

\*2 For Wireless R/C and Signal receiver unit (SRU), channel 1, 2 and 3 are selectable and should be set to same channel.

\*3 AG-150A-A (Ver.2.30 or later) supports the BM ADAPTER.

\*4 PAC-YG50ECA (Ver.1.30 or later) supports the BM ADAPTER.

\*5 Consult your dealer for restrictions when connecting both AG-150A-A and BM ADAPTER to PAC-YG50ECA.

## 3-1. R410A Piping material

The maximum operation pressure of R410A air conditioner is 4.15 MPa [601 psi]. The refrigerant piping should ensure the safety under the maximum operation pressure. You shall follow the local industrial standard.

## 3-2. Piping Design

### 3-2-1. IF 16 ports or less are in use, i.e., if only one BC controller is in use with no sub BC controller.

Note1. PQR systems do not require headers.

Note2. Indoor units sized P72-P96 should be connected to a BC controller using the Y-shaped CMY-R160C-J joint adapter. These indoor units cannot use the same BC controller ports as other units. (They must use their own individual BC controller port.)

Note3. As bends cause pressure loss on transportation of refrigerant, the fewer bends in the system, the better it is. Piping length needs to factor in the actual length and equivalent length in which the bends are counted.

Note4. Indoor units connected to the BC controller sharing one port cannot operate separately in heating and cooling modes simultaneously; i.e., they must function in either heating or cooling in tandem.

Note5. Indoor unit capacities are included in the model name. For example, PEFY-P24NMSU-E has a capacity of 24,000 BTUs.

Note6. Total "downstream indoor capacity" is the total of all the indoor units connected downstream. For example, PEFY-P24NMSU-E + PEFY-P12NMSU-E: Total Indoor Unit Capacity = P24 + P12 = P36.

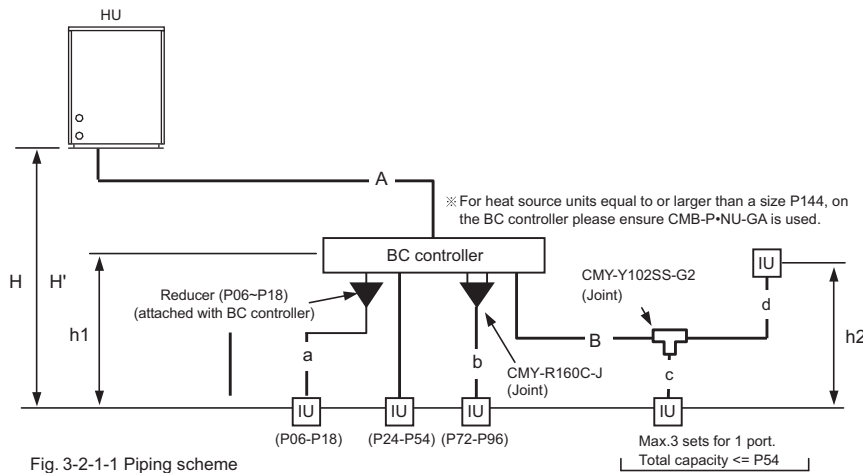

Fig. 3-2-1-1 Piping scheme

Table 3-2-1-1. Piping length limitation

Item	Piping in the figure	Max. length	Max. equivalent length
Total piping length	A+B+a+b+c+d	*1	-
Farthest IU from HU	A+B+d	165 [541']	190 [623']
Distance between HU and BC	A	110 [360'] *1	110 [360'] *1
Farthest IU from BC controller	B+d	40 [131'] *2	40 [131'] *2
Height between HU and IU (HU above IU)	H	50 [164']	-
Height between HU and IU (HU under IU)	H'	40 [131']	-
Height between IU and BC	h1	15 [49'] (10 [32']) *3	-
Height between IU and IU	h2	15 [49'] (10 [32']) *3	-

HU : Heat source Unit ; IU : Indoor Unit ; BC : BC controller

\*1. Please refer to Fig.3-2-4

\*2. Farthest Indoor from BC controller "B+d" can exceed 40 m [131 ft.] till 60 m [197 ft.] if no Indoor sized P72, P96 connected. Details refer to Fig.3-2-1-2

\*3. Distance of Indoor sized P72, P96 from BC must be less than 10 m [32 ft.], if any.

Fig. 3-2-1-2 Piping length and height between IU and BC controller

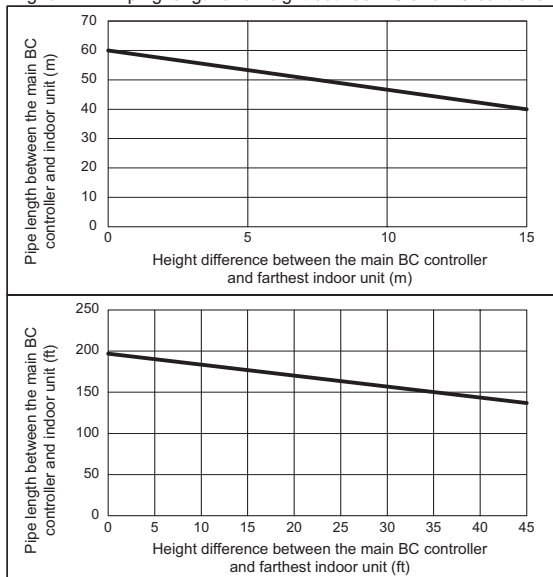

Table3-2-1-2. Bends equivalent length "M"

Heat source Model	M (m/bends [ft./bends])
P72THMU,YHMU	0.35 [1.15']
P96THMU,YHMU	0.42 [1.38']
P120THMU,YHMU	0.47 [1.54']

Table3-2-1-3. Piping "A" size selection rule (mm [in.])

Heat source Model	Pipe(High pressure)	Pipe(Low pressure)
P72THMU,YHMU	ø15.88 [5/8"]	ø19.05 [3/4"]
P96THMU,YHMU	ø19.05 [3/4"]	ø22.20 [7/8"]
P120THMU,YHMU	ø19.05 [3/4"]	ø22.20 [7/8"]

Table3-2-1-4. Piping "B" size selection rule (mm [in.])

Total down-stream Indoor capacity	Pipe(Liquid)	Pipe(Gas)
P54 or less	ø9.52 [3/8"]	ø15.88 [5/8"]

Table3-2-1-5. Piping "a", "b", "c", "d" size selection rule (mm [in.])

Indoor Unit size	Pipe(Liquid)	Pipe(Gas)
P06 to P18	ø6.35 [1/4"]	ø12.70 [1/2"]
P24 to P54	ø9.52 [3/8"]	ø15.88 [5/8"]
P72	ø9.52 [3/8"]	ø19.05 [3/4"]
P96	ø9.52 [3/8"]	ø22.20 [7/8"]

3-2-2. IF more than 16 ports are in use, or if there is more than one BC controller in use for one heat source unit

- Note1. PQRY systems do not require headers.
- Note2. Indoor units sized P72-P96 should be connected to a BC controller using the Y-shaped CMY-R160C-J joint adapter. These indoor units cannot use the same BC controller ports as other units. (They must use their own individual BC controller port.)
- Note3. As bends cause pressure loss on transportation of refrigerant, the fewer bends in the system, the better it is. Piping length needs to factor in the actual length and equivalent length in which the bends are counted.
- Note4. Indoor units connected to the BC controller sharing one port cannot operate separately in heating and cooling modes simultaneously; i.e., they must function in either heating or cooling in tandem.
- Note5. For sub BC controller CMB-P-NU-GB, the total connectable indoor unit capacity can be 126,000 BTUs or less. If two sub BC controllers are used, the total indoor unit capacity connected to BOTH sub BC controllers also cannot exceed 126,000 BTUs. For sub BC controller CMB-P1016NU-HB the total connectable indoor unit capacity can be 126,000 BTUs or less. However, if two sub controllers are used, the total indoor unit capacity connected to BOTH sub controllers must NOT exceed 168,000 BTUs.
- Note6. Indoor unit capacities are included in the model name. For example, PEFY-P24NMSU-E has a capacity of 24,000 BTUs.
- Note7. Total "downstream indoor capacity" is the total of all the indoor units connected downstream. For example, PEFY-P24NMSU-E + PEFY-P12NMSU-E: Total Indoor Unit Capacity = P24 + P12 = P36.

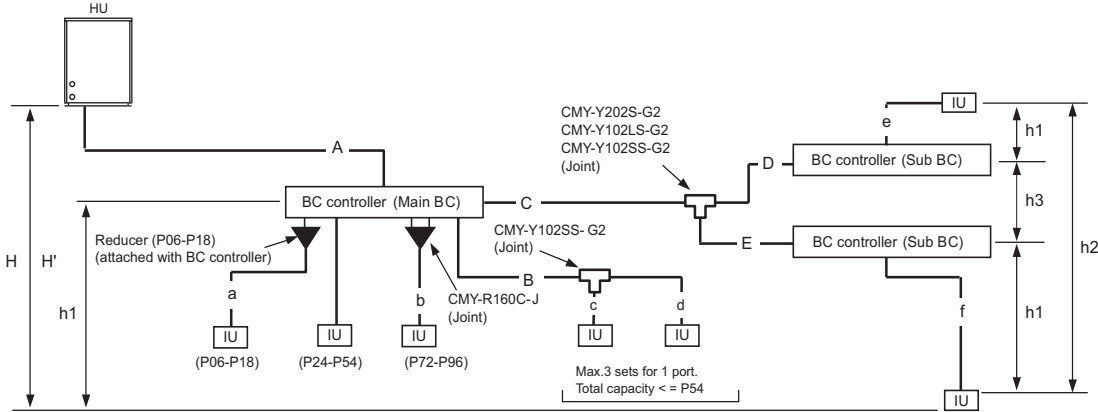

Fig. 3-2-2-1 Piping scheme

HU : Heat source unit, IU : Indoor unit

Table 3-2-2-1. Piping length limitation

Item	Piping in the figure	Max. length	Max. equivalent length (m [ft.])
Total piping length	A+B+C+D+E+a+b+c+d+e+f	*1	-
Farthest IU from HU	A+C+E+f	165 [541]	190 [623]
Distance between HU and BC	A	110 [360] *1	110 [360] *1
Farthest IU from BC controller	B+d or C+D+e or C+E+f	40 [131] *2	40 [131] *2
Height between HU and IU (HU above IU)	H	50 [164]	-
Height between HU and IU (HU under IU)	H'	40 [131]	-
Height between IU and BC	h1	15 [49] (10 [32]) *3	-
Height between IU and IU	h2	15 [49] (10 [32]) *3	-
Height between BC(Main or Sub) and BC(Sub)	h3	15 [49] (10 [32]) *4	-

Table3-2-2-2. Bent equivalent length "M"

Heat source Model	M (m/bends [ft./bends])
P72THMU,YHMU	0.35 [1.15]
P96THMU,YHMU	0.42 [1.38]
P120THMU,YHMU	0.47 [1.54]

HU : Heat source Unit ; IU : Indoor Unit ; BC : BC controller

\*1. Please refer to Fig.3-2-4

\*2. Farthest Indoor from BC controller "B+d or C+D+e or C+E+f" can exceed 40 m [131 ft.] till 60 m [197 ft.] if no Indoor sized P72, P96 connected. Details refer to Fig.3-2-2-2

\*3. Distance of Indoor sized P72, P96 from BC must be less than 10 m [32 ft.], if any.

\*4. When using 2 Sub BC controllers, max. height "h3" should be considered.

Fig. 3-2-2-2 Piping length and height between IU and BC controller

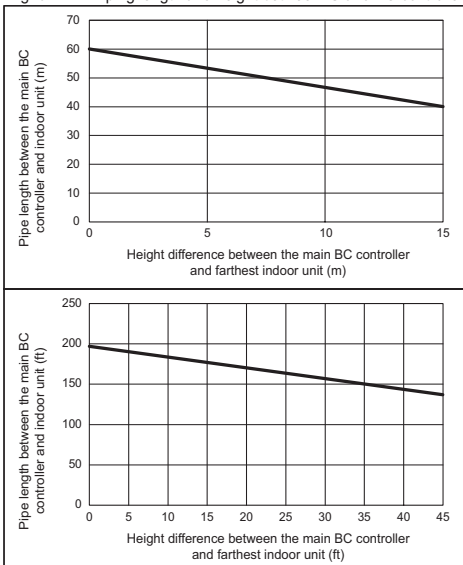

Table3-2-2-3. Piping "A" size selection rule (mm [in.])

Heat source Model	Pipe(High pressure)	Pipe(Low pressure)
P72THMU,YHMU	ø15.88 [5/8"]	ø19.05 [3/4"]
P96THMU,YHMU	ø19.05 [3/4"]	ø22.20 [7/8"]
P120THMU,YHMU	ø19.05 [3/4"]	ø28.58 [1-1/8"]

Table3-2-2-4. Piping "B" size selection rule (mm [in.])

Total down-stream indoor capacity	Pipe(Liquid)	Pipe(Gas)
P54 or less	ø9.52 [3/8"]	ø15.88 [5/8"]

Table3-2-2-5. Piping "C", "D", "E" size selection rule (mm [in.])

Total down-stream indoor capacity	Pipe(Liquid)	Pipe(HP Gas)	Pipe(LP Gas)
P72 or less	ø9.52 [3/8"]	ø15.88 [5/8"]	ø19.05 [3/4"]
P73 to P108	ø9.52 [3/8"]	ø19.05 [3/4"]	ø22.20 [7/8"]
P109 to P126	ø12.70 [1/2"]	ø19.05 [3/4"]	ø28.58 [1-1/8"]
P127 to P144	ø12.70 [1/2"]	ø22.20 [7/8"]	ø28.58 [1-1/8"]
P145 to P168	ø15.88 [5/8"]	ø22.20 [7/8"]	ø28.58 [1-1/8"]

HP : High pressure, LP:Low pressure

Table3-2-2-6. Piping "a", "b", "c", "d" size selection rule (mm [in.])

Indoor Unit size	Pipe(Liquid)	Pipe(Gas)
P06 to P18	ø6.35 [1/4"]	ø12.70 [1/2"]
P24 to P54	ø9.52 [3/8"]	ø15.88 [5/8"]
P72	ø9.52 [3/8"]	ø19.05 [3/4"]
P96	ø9.52 [3/8"]	ø22.20 [7/8"]

## 3-2-3. IF more than 16 ports are in use, or if there is more than one BC controller in use for two heat source units

- Note1. PQRY systems do not require headers.
- Note2. Indoor units sized P72-P96 should be connected to a BC controller using the Y-shaped CMY-R160C-J joint adapter. These indoor units cannot use the same BC controller ports as other units. (They must use their own individual BC controller port.)
- Note3. As bends cause pressure loss on transportation of refrigerant, the fewer bends in the system, the better it is. Piping length needs to factor in the actual length and equivalent length in which the bends are counted.
- Note4. Indoor units connected to the BC controller sharing one port cannot operate separately in heating and cooling modes simultaneously; i.e., they must function in either heating or cooling in tandem.

- Note5. For sub BC controller CMB-P-NU-GB, the total connectable indoor unit capacity can be 126,000 BTUs or less. If two sub BC controllers are used, the total indoor unit capacity connected to BOTH sub BC controllers also cannot exceed 126,000 BTUs.  
For sub BC controller CMB-P1016NU-HB the total connectable indoor unit capacity can be 126,000 BTUs or less. However, if two sub controllers are used, the total indoor unit capacity connected to BOTH sub controllers must NOT exceed 168,000 BTUs.
- Note6. Indoor unit capacities are included in the model name. For example, PEFY-P24NMSU-E has a capacity of 24,000 BTUs.
- Note7. Total "downstream indoor capacity" is the total of all the indoor units connected downstream. For example, PEFY-P24NMSU-E + PEFY-P12NMSU-E: Total Indoor Unit Capacity = P24 + P12 = P36.

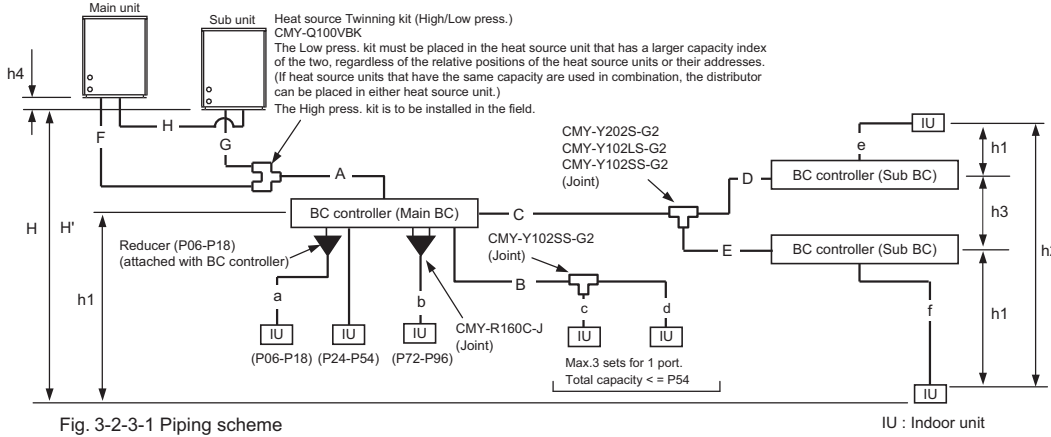

Fig. 3-2-3-1 Piping scheme

IU : Indoor unit

Table3-2-3-1. Piping length limitation

Item	Piping in the figure	Max. length	Max. equivalent length
Total piping length	F+G+H+A+B+C+D+E+a+b+c+d+e+f	*1	-
Farthest IU from HU	F(G)+A+C+E+f	165 [541']	190 [623']
Distance between HU and BC	F(G)+A	110 [360'] *1	110 [360'] *1
Farthest IU from BC controller	B+d or C+D+e or C+E+f	40 [131'] *2	40 [131'] *2
Height between HU and IU (HU above IU)	H	50 [164']	-
Height between HU and IU (HU under IU)	H'	40 [131']	-
Height between IU and BC	h1	15 [49'] (10 [32']) *3	-
Height between IU and IU	h2	15 [49'] (10 [32']) *3	-
Height between BC(Main or Sub) and BC(Sub)	h3	15 [49'] (10 [32']) *4	-
Distance between Main unit and Sub unit	F+G or H	5 [16']	-
Height between Main unit and Sub unit	h4	0.1 [0.3']	-

HU : Heat source Unit ; IU : Indoor Unit ; BC : BC controller

\*1. Please refer to Fig.3-2-4

\*2. Farthest Indoor from BC controller "B+d or C+D+e or C+E+f" can exceed 40 m [131 ft.] till 60 m [197 ft.] if no Indoor sized P72, P96 connected. Details refer to Fig.3-2-3-2

\*3. Distance of Indoor sized P72, P96 from BC must be less than 10 m [32 ft.], if any.

\*4. When using 2 Sub BC controllers, max. height "h3" should be considered.

Table3-2-3-2. Bent equivalent length "M"

Heat source Model	M (m/bends [ft./bends])
P144TSHMU.YSHMU	0.50 [1.64']
P168TSHMU.YSHMU	0.50 [1.64']
P192TSHMU.YSHMU	0.50 [1.64']
P216TSHMU.YSHMU	0.50 [1.64']
P240TSHMU.YSHMU	0.50 [1.64']

Fig. 3-2-3-2 Piping length and height between IU and BC controller

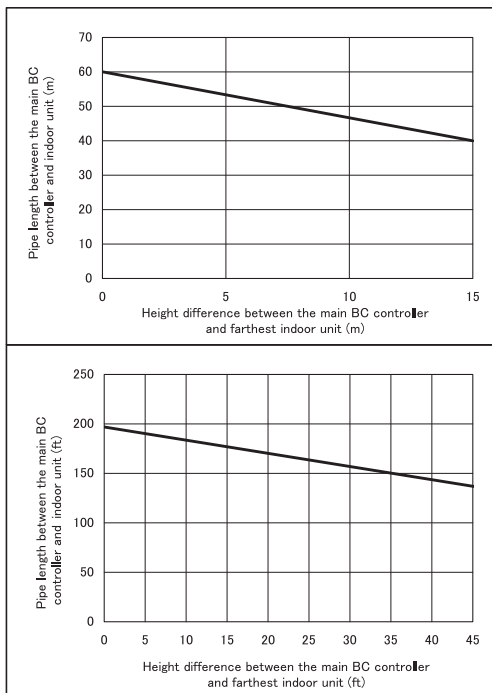

Table3-2-3-3. Piping "A" size selection rule

Heat source Model	Pipe(High pressure)	Pipe(Low pressure)
P144TSHMU.YSHMU	ø22.20 [7/8"]	ø28.58 [1-1/8"]
P168TSHMU.YSHMU	ø22.20 [7/8"]	ø28.58 [1-1/8"]
P192TSHMU.YSHMU	ø22.20 [7/8"]	ø28.58 [1-1/8"]
P216TSHMU.YSHMU	ø28.58 [1-1/8"]	ø28.58 [1-1/8"]
P240TSHMU.YSHMU	ø28.58 [1-1/8"]	ø28.58 [1-1/8"]

Table3-2-3-4. Piping "B" size selection rule

Total down-stream Indoor capacity	Pipe(Liquid)	Pipe(Gas)
P54 or less	ø9.52 [3/8"]	ø15.88 [5/8"]

Table3-2-3-5. Piping "C", "D", "E" size selection rule

Total down-stream Indoor capacity	Pipe(Liquid)	Pipe(HP Gas)	Pipe(LP Gas)
P72 or less	ø9.52 [3/8"]	ø15.88 [5/8"]	ø19.05 [3/4"]
P73 to P108	ø9.52 [3/8"]	ø19.05 [3/4"]	ø22.20 [7/8"]
P109 to P126	ø12.70 [1/2"]	ø19.05 [3/4"]	ø28.58 [1-1/8"]
P127 to P144	ø12.70 [1/2"]	ø22.20 [7/8"]	ø28.58 [1-1/8"]
P145 to P168	ø15.88 [5/8"]	ø22.20 [7/8"]	ø28.58 [1-1/8"]

HP : High pressure, LP:Low pressure

Table3-2-3-6. Piping "F", "G", "H" size selection rule

Heat source Model	Pipe(High pressure)	Pipe(Low pressure)
P72THMU.YHMU	ø15.88 [5/8"]	ø19.05 [3/4"]
P96THMU.YHMU	ø19.05 [3/4"]	ø22.20 [7/8"]
P120THMU.YHMU	ø19.05 [3/4"]	ø28.58 [1-1/8"]

Table3-2-3-7. Piping "a", "b", "c", "d" size selection rule

Indoor Unit size	Pipe(Liquid)	Pipe(Gas)
P06 to P18	ø6.35 [1/4"]	ø12.70 [1/2"]
P24 to P54	ø9.52 [3/8"]	ø15.88 [5/8"]
P72	ø9.52 [3/8"]	ø19.05 [3/4"]
P96	ø9.52 [3/8"]	ø22.20 [7/8"]

## 3-2-4. Total piping length restrictions (m)

[PQRY-P72, 96, 120THMU-A/YHMU-A]

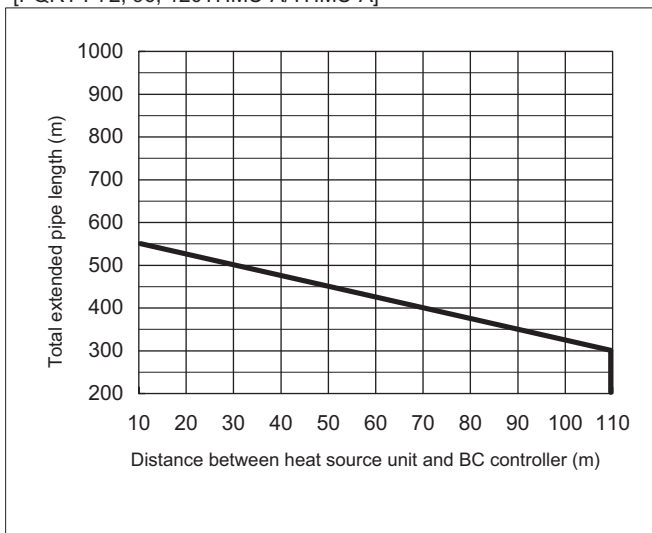

[PQRY-P144, 168, 192, 216, 240TSHMU-A/YSHMU-A]

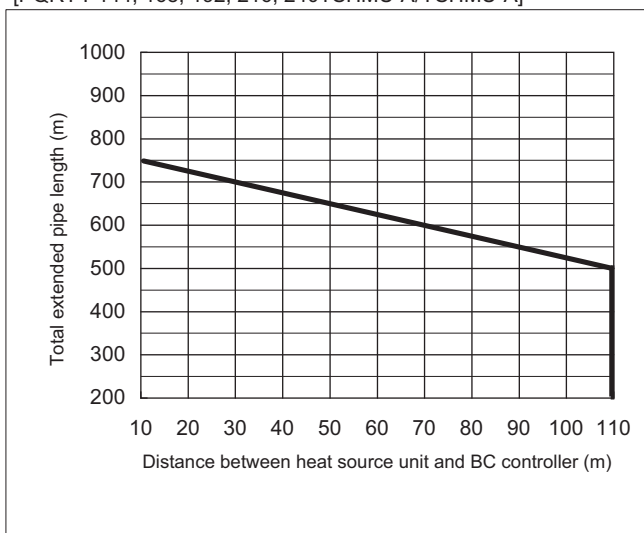

## 3-2-5. Total piping length restrictions (ft.)

[PQRY-P72, 96, 120THMU-A/YHMU-A]

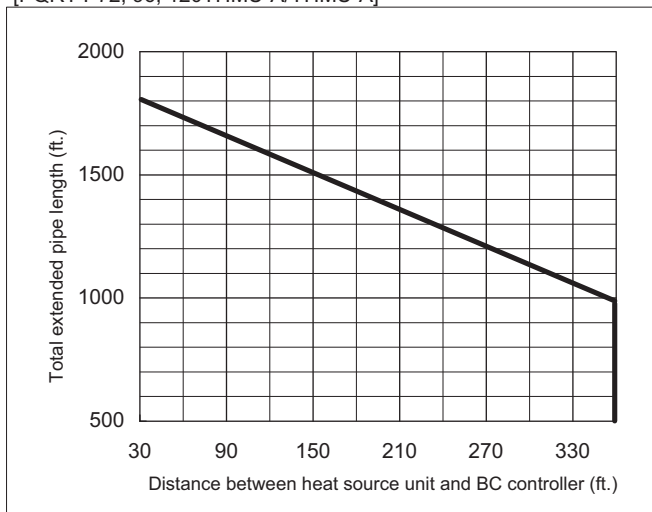

[PQRY-P144, 168, 192, 216, 240TSHMU-A/YSHMU-A]

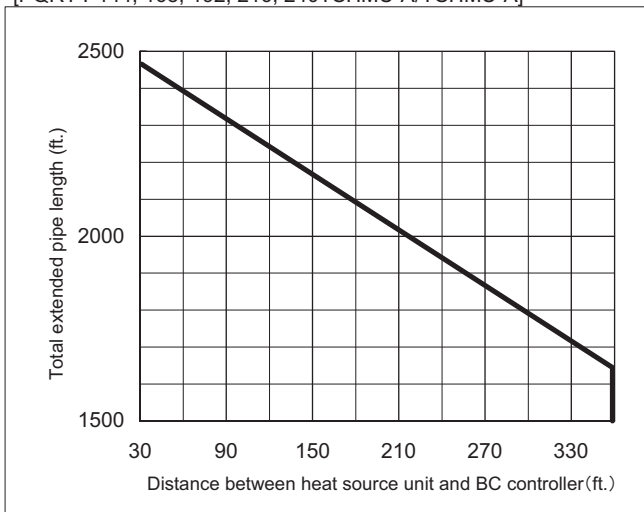

S.D. WR2

## 3-3. Refrigerant charging calculation

Sample connection (with 3 BC controller and 6 indoor units)

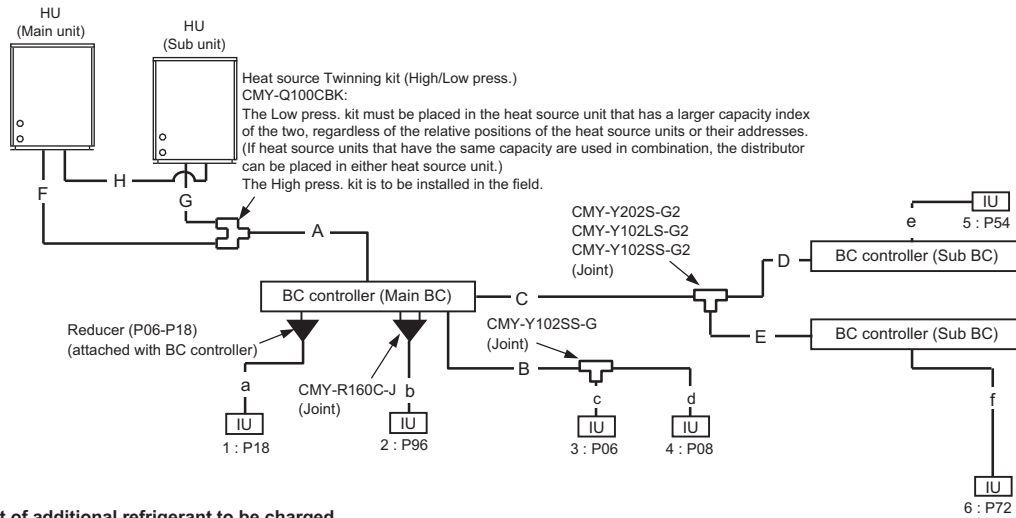

### Amount of additional refrigerant to be charged

Refrigerant for extended pipes (field piping) is not factory-charged to the heat source unit. Add an appropriate amount of refrigerant for each pipes on site. Record the size of each high pressure pipe and liquid pipe, and the amount of refrigerant that was charged on the heat source unit for future reference.

### Calculating the amount of additional refrigerant to be charged

The amount of refrigerant to be charged is calculated with the size of the on-site-installed high pressure pipes and liquid pipes, and their length.

Calculate the amount of refrigerant to be charged according to the formula below.  
Round up the calculation result to the nearest 0.1kg[4oz]. (i.e., 16.08 kg = 16.1 kg)

#### <Amount of additional refrigerant to be charged>

#### Calculating the amount of additional refrigerant to be charged

Additional refrigerant charge	=	High pressure pipe size Total length of ø 28.58mm[1-1/8 in]	+	High pressure pipe size Total length of ø 22.2mm[7/8 in]	+	High pressure pipe size Total length of ø 19.05mm[3/4 in]	+	High pressure pipe size Total length of ø 15.88mm[5/8 in]
(kg)[oz]		(m) × 0.36(kg/m) (ft) × 3.88(oz/ft)		(m) × 0.23(kg/m) (ft) × 2.48(oz/ft)		(m) × 0.16(kg/m) (ft) × 1.73(oz/ft)		(m) × 0.11(kg/m) (ft) × 1.19(oz/ft)
	+	Liquid Piping size Total length of ø 15.88mm[5/8 in]		Liquid Piping size Total length of ø 12.7mm[1/2 in]		Liquid Piping size Total length of ø 9.52mm[3/8 in]		Liquid Piping size Total length of ø 6.35mm[1/4 in]
		(m) × 0.2(kg/m) (ft) × 2.16(oz/ft)		(m) × 0.12(kg/m) (ft) × 1.30(oz/ft)		(m) × 0.06(kg/m) (ft) × 0.65(oz/ft)		(m) × 0.024(kg/m) (ft) × 0.26(oz/ft)

BC controller (Standard / Main)	+	BC controller (Main) HA-Type	+	BC controller (Sub) Total Units	Charged amount	+	Total Capacity of Connected Indoor Units	Charged amount
3.0 kg[106oz]		2.0 kg[71oz]		1	1.0 kg[36oz]		Models - 27	2.0 kg [71 oz]
				2	2.0 kg[71oz]		Models 28 - 54	2.5 kg [89 oz]
							Models 55 - 126	3.0 kg [106 oz]
							Models 127 - 144	3.5 kg [124 oz]
							Models 145 - 180	4.5 kg [159 oz]
							Models 181 - 234	5.0 kg [177 oz]
							Models 235 - 273	6.0 kg [212 oz]
							Models 274 - 307	8.0 kg [283 oz]
							Models 308 - 342	9.0 kg [318 oz]
							Models 343 - 411	10.0 kg [353 oz]
							Models 412 -	12.0 kg [424 oz]

### Amount of factory charged refrigerant

Heat source unit Model	Charged amount
P72	5.0 kg
P96	
P120	
P144	

### Sample calculation

Indoor	
A : ø28.58 [1-1/8"]	40m [131ft.]
B : ø9.52 [3/8"]	10m [32ft.]
C : ø12.70 [1/2"]	10m [32ft.]
D : ø9.52 [3/8"]	5m [16ft.]
E : ø9.52 [3/8"]	5m [16ft.]
F : ø22.20 [7/8"]	2m [6ft.]
G : ø22.20 [7/8"]	1m [4ft.]
Total length for each pipe size :	ø28.58 A = 40m [131ft.]
	ø22.20 F+G = 2+1 = 3m [10ft.]
	ø12.70 C = 10m [32ft.]
	ø9.52 B+D+E+b+e+f = 36m [116ft.]
	ø6.35 a+c+d = 10m [32ft.]
Therefore, additional refrigerant charge (kg)	= 40×0.36+3×0.23+10×0.12+36×0.06+10×0.024+3.0+2.0+6.0 = 29.69kg
	≈ 29.7kg
or	
Therefore, additional refrigerant charge (oz)	= 131×3.88+10×2.48+32×1.30+116×0.65+32×0.26+106+71+212 = 1047.4oz
	≈ 1048oz

### Limitation of the amount of refrigerant to be charged

The above calculation result of the amount of refrigerant to be charged must become below the value in the table below.

Heat source unit model	P72	P96	P120	P144	P168	P192	P216	P240
Maximum amount of refrigerant *1 kg	26.3	32.8	33.8	45.5	47.0	58.2	67.2	70.9
(oz)	928	1157	1192	1605	1658	2053	2370	2501

\*1 Amount of additional refrigerant to be charged on site.

## 4-1. Requirement on installation site

1. No direct thermal radiation to the unit.
2. No possibility of annoying the neighbors by the sound of the unit.

**Valves and refrigerant flow on the Heat source unit may generate noise.**

3. Avoid the sites where strong winds blow.
4. With strength to bear the weight of the unit.
5. Drain flow from the unit is cared at heating mode.
6. Enough space for installation and service as shown at 4-2.
7. Avoid the sites where acidic solutions or chemical sprays (sulfur series) are used frequently.
8. The unit should be secure from combustible gas, oil, steam, chemical gas like acidic solution, sulfur gas and so on.

## 4-2. Spacing

In case of single installation, 600mm or more of back space as front space makes easier access when servicing the unit from rear side.

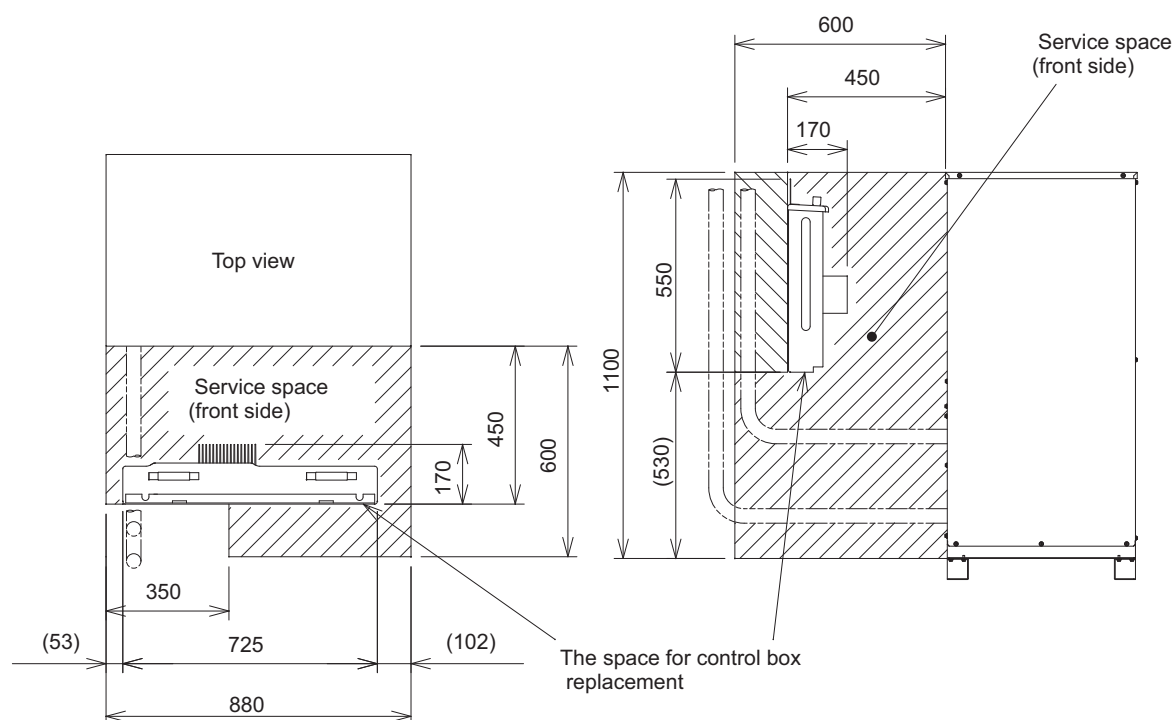



4-3. Piping direction

<Model : PQHY, PQRY-P-THMU-A/YHMU-A>

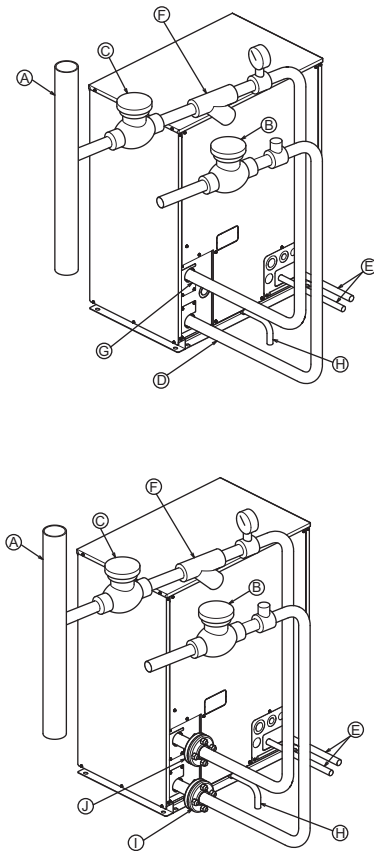

- (A) Main circulating water pipe
- (B) Shutoff valve
- (C) Shutoff valve
- (D) Water outlet (lower)
- (E) Refrigerant pipes
- (F) Y-type strainer
- (G) Water inlet (upper)
- (H) Drain pipe
- (I) Water outlet flange (lower)
- (J) Water inlet flange (upper)

1. Insulation installation

With City Multi WY/ WR2 Series piping, as long as the temperature range of the circulating water is kept to average temperatures year-round (29.4°C[85°F] in the summer, 21.1°C[70°F] in the winter), there is no need to insulate or otherwise protect indoor piping from exposure. You should use insulation in the following situations:

- Any heat source piping.
- Indoor piping in cold-weather regions where frozen pipes are a problem.
- When air coming from the outside causes condensation to form on piping.
- Any drainage piping.

2. Water processing and water quality control

To preserve water quality, use the closed type of cooling tower for WY/ WR2. When the circulating water quality is poor, the water heat exchanger can develop scales, leading to a reduction in heat-exchange power and possible corrosion of the heat exchanger. Please pay careful attention to water processing and water quality control when installing the water circulation system.

- Removal of foreign objects or impurities within the pipes. During installation, be careful that foreign objects, such as welding fragments, sealant particles, or rust, do not enter the pipes.
- Water Quality Processing
  - ① Depending on the quality of the cold-temperature water used in the air conditioner, the copper piping of the heat exchanger may become corroded. We recommend regular water quality processing. Cold water circulation systems using open heat storage tanks are particularly prone to corrosion. When using an open-type heat storage tank, install a water-to-water heat exchanger, and use a closed-loop circuit on the air conditioner side. If a water supply tank is installed, keep contact with air to a minimum, and keep the level of dissolved oxygen in the water no higher than 1mg/ℓ.
  - ② Water quality standard

Items	Lower mid-range temperature water system		Tendency		
	Recirculating water [20<T<60°C] [68<T<140°F]	Make-up water	Corrosive	Scale-forming	
Standard items	pH (25°C)[77°F]	7.0 ~ 8.0	7.0 ~ 8.0	○	○
	Electric conductivity (mS/m) (25°C)[77°F] (μS/cm) (25°C)[77°F]	30 or less [300 or less]	30 or less [300 or less]	○	○
	Chloride ion (mg Cl/ℓ)	50 or less	50 or less	○	
	Sulfate ion (mg SO <sub>4</sub> <sup>2-</sup> /ℓ)	50 or less	50 or less	○	
	Acid consumption (pH4.8) (mg CaCO <sub>3</sub> /ℓ)	50 or less	50 or less		○
	Total hardness (mg CaCO <sub>3</sub> /ℓ)	70 or less	70 or less		○
	Calcium hardness (mg CaCO <sub>3</sub> /ℓ)	50 or less	50 or less		○
Reference items	Ionic silica (mg SiO <sub>2</sub> /ℓ)	30 or less	30 or less		○
	Iron (mg Fe/ℓ)	1.0 or less	0.3 or less	○	○
	Copper (mg Cu/ℓ)	1.0 or less	0.1 or less	○	
	Sulfide ion (mg S <sup>2-</sup> /ℓ)	not to be detected	not to be detected	○	
	Ammonium ion (mg NH <sub>4</sub> <sup>+</sup> /ℓ)	0.3 or less	0.1 or less	○	
	Residual chlorine (mg Cl/ℓ)	0.25 or less	0.3 or less	○	
	Free carbon dioxide (mg CO <sub>2</sub> /ℓ)	0.4 or less	4.0 or less	○	
Ryzner stability index	-	-	○	○	

Reference : Guideline of Water Quality for Refrigeration and Air Conditioning Equipment. (JRA GL02E-1994)

- ③ Please consult with a water quality control specialist about water quality control methods and water quality calculations before using anti-corrosive solutions for water quality management.
- ④ When replacing a previously installed air conditioning device (even when only the heat exchanger is being replaced), first conduct a water quality analysis and check for possible corrosion. Corrosion can occur in cold-water systems even if there has been no prior signs of corrosion. If the water quality level has dropped, please adjust water quality sufficiently before replacing the unit.

S.D. WR2

## 5-1. General precautions

### 5-1-1. Usage

- ♦The air-conditioning system described in this Data Book is designed for human comfort.
- ♦This product is not designed for preservation of food, animals, plants, precision equipment, or art objects. To prevent quality loss, do not use the product for purposes other than what it is designed for.
- ♦To reduce the risk of water leakage and electric shock, do not use the product for air-conditioning vehicles or vessels.

### 5-1-2. Installation environment

- ♦Do not install any unit other than the dedicated unit in a place where the voltage changes a lot, large amounts of mineral oil (e.g., cutting oil) are present, cooking oil may splash, or a large quantity of steam can be generated such as a kitchen.
- ♦Do not install the unit in acidic or alkaline environment.
- ♦Installation should not be performed in the locations exposed to chlorine or other corrosive gases. Avoid near a sewer.
- ♦To reduce the risk of fire, do not install the unit in a place where flammable gas may be leaked or inflammable material is present.
- ♦This air conditioning unit has a built-in microcomputer. Take the noise effects into consideration when deciding the installation position. Especially in a place where antenna or electronic device are installed, it is recommended that the air conditioning unit be installed away from them.
- ♦Install the unit on a solid foundation according to the local safety measures against typhoons, wind gusts, and earthquakes to prevent the unit from being damaged, toppling over, and falling.

### 5-1-3. Backup system

- ♦In a place where air conditioner's malfunctions may exert crucial influence, it is recommended to have two or more systems of single outdoor units with multiple indoor units.

### 5-1-4. Unit characteristics

- ♦Heat pump efficiency depends on outdoor temperature. In the heating mode, performance drops as the outside air temperature drops. In cold climates, performance can be poor. Warm air would continue to be trapped near the ceiling and the floor level would continue to stay cold. In this case, heat pumps require a supplemental heating system or air circulator. Before purchasing them, consult your local distributor for selecting the unit and system.
- ♦When the outdoor temperature is low and the humidity is high, the heat exchanger on the outdoor unit side tends to collect frost, which reduces its heating performance. To remove the frost, Auto-defrost function will be activated and the heating mode will temporarily stop for 3-10 minutes. Heating mode will automatically resume upon completion of defrost process.
- ♦Air conditioner with a heat pump requires time to warm up the whole room after the heating operation begins, because the system circulates warm air in order to warm up the whole room.
- ♦The sound levels were obtained in an anechoic room. The sound levels during actual operation are usually higher than the simulated values due to ambient noise and echoes. Refer to the section on "SOUND LEVELS" for the measurement location.
- ♦Depending on the operation conditions, the unit generates noise caused by valve actuation, refrigerant flow, and pressure changes even when operating normally. Please consider to avoid location where quietness is required. For BC controller, it is recommended to unit to be installed in places such as ceilings of corridor, restrooms and plant rooms.
- ♦The total capacity of the connected indoor units can be greater than the capacity of the outdoor unit. However, when the connected indoor units operate simultaneously, each unit's capacity may become smaller than the rated capacity.
- ♦When the unit is started up for the first time within 12 hours after power on or after power failure, it performs initial startup operation (capacity control operation) to prevent damage to the compressor. The initial startup operation requires 90 minutes maximum to complete, depending on the operation load.

### 5-1-5. Relevant equipment

- ♦Use an earth leakage breaker (ELB) with medium sensitivity, and an activation speed of 0.1 second or less.
- ♦Consult your local distributor or a qualified technician when installing an earth leakage breaker.
- ♦If the unit is inverter type, select an earth leakage breaker for handling high harmonic waves and surges.
- ♦Leakage current is generated not only through the air conditioning unit but also through the power wires. Therefore, the leakage current of the main power supply is greater than the total leakage current of each unit. Take into consideration the capacity of the earth leakage breaker or leakage alarm when installing one at the main power supply. To measure the leakage current simply on site, use a measurement tool equipped with a filter, and clamp all the four power wires together. The leakage current measured on the ground wire may not accurate because the leakage current from other systems may be included to the measurement value.
- ♦Do not install a phase advancing capacitor on the unit connected to the same power system with an inverter type unit and its equipment.
- ♦If a large current flows due to the product malfunctions or faulty wiring, both the earth leakage breaker on the product side and the upstream overcurrent breaker may trip almost at the same time. Separate the power system or coordinate all the breakers depending on the system's priority level.

### 5-1-6. Unit installation

- Your local distributor or a qualified technician must read the Installation Manual that is provided with each unit carefully before performing installation work.
- Consult your local distributor or a qualified technician when installing the unit. Improper installation by an unqualified person may result in water leakage, electric shock, or fire.
- Ensure there is enough space around each unit.

### 5-1-7. Optional accessories

- Only use accessories recommended by Mitsubishi Electric. Consult your local distributor or a qualified technician when installing them. Improper installation by an unqualified person may result in water leakage, electric leakage, system breakdown, or fire.
- Some optional accessories may not be compatible with the air conditioning unit to be used or may not be suitable for the installation conditions. Check the compatibility when considering any accessories.
- Note that some optional accessories may affect the air conditioner's external form, appearance, weight, operating sound, and other characteristics.

### 5-1-8. Operation/Maintenance

- Read the Instruction Book that is provided with each unit carefully prior to use.
- Maintenance or cleaning of each unit may be risky and require expertise. Read the Instruction Book to ensure safety. Consult your local distributor or a qualified technician when special expertise is required such as when the indoor unit needs to be cleaned.

## 5-2. Precautions for Indoor unit

### 5-2-1. Operating environment

- The refrigerant (R410A) used for air conditioner is non-toxic and nonflammable. However, if the refrigerant leaks, the oxygen level may drop to harmful levels. If the air conditioner is installed in a small room, measures must be taken to prevent the refrigerant concentration from exceeding the safety limit even if the refrigerant should leak.
- If the units operate in the cooling mode at the humidity above 80%, condensation may collect and drip from the indoor units.

### 5-2-2. Unit characteristics

- The return air temperature display on the remote controller may differ from the ones on the other thermometers.
- The clock on the remote controller may be displayed with a time lag of approximately one minute every month.
- The temperature using a built-in temperature sensor on the remote controller may differ from the actual room temperature due to the effect of the wall temperature.
- Use a built-in thermostat on the remote controller or a separately-sold thermostat when indoor units installed on or in the ceiling operate the automatic cooling/heating switchover.
- The room temperature may rise drastically due to Thermo OFF in the places where the air conditioning load is large such as computer rooms.
- Be sure to use a regular filter. If an irregular filter is installed, the unit may not operate properly, and the operation noise may increase.
- The room temperature may rise over the preset temperature in the environment where the heating air conditioning load is small.

### 5-2-3. Unit installation

- For simultaneous cooling/heating operation type air conditioners (R2, H2i R2, WR2 series), the G-type BC controller cannot be connected to the P144 outdoor unit model or above, and the G- and GA-type BC controllers cannot be connected to the P264 model or above. The GB- and HB-type BC controllers (sub) cannot be connected to the outdoor unit directly, and be sure to use them with GA- and HA-type BC controllers (main).
- The insulation for low pressure pipe between the BC controller and outdoor unit shall be at least 20 mm thick. If the unit is installed on the top floor or in a high-temperature, high-humidity environment, thicker insulation may be necessary.
- Do not have any branching points on the downstream of the refrigerant pipe header.
- When a field-supplied external thermistor is installed or when a device for the demand control is used, abnormal stop of the unit or damage of the electromagnetic contactor may occur. Consult your local distributor for details.
- When indoor units operate a fresh air intake, install a filter in the duct (field-supplied) to remove the dust from the air.
- The 4-way or 2-way Airflow Ceiling Cassette Type units that have an outside air inlet can be connected to the duct, but need a booster fan to be installed at site. Refer to the chapter "Indoor Unit" for the available range for fresh air intake volume.
- Operating fresh air intake on the indoor unit may increase the sound pressure level.

### 5-3. Precautions for Outdoor unit/Heat source unit

#### 5-3-1. Installation environment

- Outdoor unit with salt-resistant specification is recommended to use in a place where it is subject to salt air.
- Even when the unit with salt-resistant specification is used, it is not completely protected against corrosion. Be sure to follow the directions or precautions described in Instructions Book and Installation Manual for installation and maintenance. The salt-resistant specification is referred to the guidelines published by JRAIA (JRA9002).
- Install the unit in a place where the flow of discharge air is not obstructed. If not, the short-cycling of discharge air may occur.
- Provide proper drainage around the unit base, because the condensation may collect and drip from the outdoor units. Provide water-proof protection to the floor when installing the units on the rooftop.
- In a region where snowfall is expected, install the unit so that the outlet faces away from the direction of the wind, and install a snow guard to protect the unit from snow. Install the unit on a base approximately 50 cm higher than the expected snowfall. Close the openings for pipes and wiring, because the ingress of water and small animals may cause equipment damage. If SUS snow guard is used, refer to the Installation Manual that comes with the snow guard and take caution for the installation to avoid the risk of corrosion.
- When the unit is expected to operate continuously for a long period of time at outside air temperatures of below 0°C, take appropriate measures, such as the use of a unit base heater, to prevent icing on the unit base. (Not applicable to the PUMY-P-NHMu series)
- Install the snow guard so that the outlet/inlet faces away from the direction of the wind.
- When the snow accumulates approximately 50 cm or more on the snow guard, remove the snow from the guard. Install a roof that is strong enough to withstand snow loads in a place where snow accumulates.
- Provide proper protection around the outdoor units in places such as schools to avoid the risk of injury.
- A cooling tower and heat source water circuit should be a closed circuit that water is not exposed to the atmosphere. When a tank is installed to ensure that the circuit has enough water, minimize the contact with outside air so that the oxygen from being dissolved in the water should be 1 mg/L or less.
- Install a strainer (50 mesh or more recommended) on the water pipe inlet on the heat source unit.
- Interlock the heat source unit and water circuit pump.
- Note the followings to prevent the freeze bursting of pipe when the heat source unit is installed in a place where the ambient temperature can be 0°C or below.
- Keep the water circulating to prevent it from freezing when the ambient temperature is 0°C or below.
- Before a long period of non use, be sure to purge the water out of the unit.

#### 5-3-2. Circulating water

- Follow the guidelines published by JRAIA (JRA-GL02-1994) to check the water quality of the water in the heat source unit regularly.
- A cooling tower and heat source water circuit should be a closed circuit that water is not exposed to the atmosphere. When a tank is installed to ensure that the circuit has enough water, minimize the contact with outside air so that the oxygen from being dissolved in the water should be 1 mg/L or less.

#### 5-3-3. Unit characteristics

- When the Thermo ON and OFF is frequently repeated on the indoor unit, the operation status of outdoor units may become unstable.

#### 5-3-4. Relevant equipment

- Provide grounding in accordance with the local regulations.

## 5-4. Precautions for Control-related items

### 5-4-1. Product specification

- To introduce the MELANS system, a consultation with us is required in advance. Especially to introduce the electricity charge apportioning function or energy-save function, further detailed consultation is required. Consult your local distributor for details.
- Billing calculation for AG-150A-A, GB-50ADA-A, EB-50GU-A, TG-2000A, or the billing calculation unit is unique and based on our original method. (Backup operation is included.) It is not based on the metering method, and do not use it for official business purposes. It is not the method that the amount of electric power consumption (input) by air conditioner is calculated. Note that the electric power consumption by air conditioner is apportioned by using the ratio corresponding to the operation status (output) for each air conditioner (indoor unit) in this method.
- In the apportioned billing function for AG-150A-A, GB-50ADA-A, and EB-50GU-A, use separate watt-hour meters for A-control units, K-control units<sup>\*1</sup>, and packaged air conditioner for City Multi air conditioners. It is recommended to use an individual watt-hour meter for the large-capacity indoor unit (with two or more addresses).
- When using the peak cut function on the AG-150A-A, GB-50ADA-A or EB-50GU-A, note that the control is performed once every minute and it takes time to obtain the effect of the control. Take appropriate measures such as lowering the criterion value. Power consumption may exceed the limits if AG-150A-A, GB-50ADA-A or EB-50GU-A malfunctions or stops. Provide a back-up remedy as necessary.
- The controllers cannot operate while the indoor unit is OFF. (No error)  
Turn ON the power to the indoor unit when operating the controllers.
- When using the interlocked control function on the AG-150A-A, GB-50ADA-A, EB-50GU-A, PAC-YG66DCA, or PAC-YG63MCA, do not use it for the control for the fire prevention or security. (This function should never be used in the way that would put people's lives at risk.) Provide any methods or circuit that allow ON/OFF operation using an external switch in case of failure.

### 5-4-2. Installation environment

- The surge protection for the transmission line may be required in areas where lightning strikes frequently occur.
- A receiver for a wireless remote controller may not work properly due to the effect of general lighting. Leave a space of at least 1 m between the general lighting and receiver.
- When the Auto-elevating panel is used and the operation is made by using a wired remote controller, install the wired remote controller to the place where all air conditioners controlled (at least the bottom part of them) can be seen from the wired remote controller. If not, the descending panel may cause damage or injury, and be sure to use a wireless remote controller designed for use with elevating panel (sold separately).
- Install the wired remote controller (switch box) to the place where the following conditions are met.
- Where installation surface is flat
- Where the remote controller can detect an accurate room temperature  
The temperature sensors that detect a room temperature are installed both on the remote controller and indoor unit. When a room temperature is detected using the sensor on the remote controller, the main remote controller is used to detect a room temperature. In this case, follow the instructions below.
- Install the controller in a place where it is not subject to the heat source.  
(If the remote controller faces direct sunlight or supply air flow direction, the remote controller cannot detect an accurate room temperature.)
- Install the controller in a place where an average room temperature can be detected.
- Install the controller in a place where no other wires are present around the temperature sensor.  
(If other wires are present, the remote controller cannot detect an accurate room temperature.)
- To prevent unauthorized access, always use a security device such as a VPN router when connecting AG-150A-A, GB-50ADA-A, EB-50GU-A or TG-2000A to the Internet.

\*1.EB-50GU-A cannot be used to control K-control units.

The installer and/or air conditioning system specialist shall secure safety against refrigerant leakage according to local regulations or standards. The following standard may be applicable if no local regulation or standard is available.

## 6-1. Refrigerant property

R410A refrigerant is harmless and incombustible. The R410A is heavier than the indoor air in density. Leakage of the refrigerant in a room has possibility to lead to a hypoxia situation. Therefore, the Critical concentration specified below shall not be exceeded even if the leakage happens.

### • Critical concentration

Critical concentration hereby is the refrigerant concentration in which no human body would be hurt if immediate measures can be taken when refrigerant leakage happens.

**Critical concentration of R410A: 0.44kg/m<sup>3</sup>**  
**(The weight of refrigeration gas per 1 m<sup>3</sup> air conditioning space.);**

\* The Critical concentration is subject to ISO5149, EN378-1.

For the CITY MULTI system, the concentration of refrigerant leaked should not have a chance to exceed the Critical concentration in any situation.

## 6-2. Confirm the Critical concentration and take countermeasure

The maximum refrigerant leakage concentration (Rmax) is defined as the result of the possible maximum refrigerant weight (Wmax) leaked into a room divided by its room capacity (V). It is referable to Fig. 6-1. The refrigerant of Heat source unit here includes its original charge and additional charge at the site.

The additional charge is calculated according to the refrigerant charging calculation of each kind of Heat source unit, and shall not be over charged at the site. Procedure 6-2-1~3 tells how to confirm maximum refrigerant leakage concentration (Rmax) and how to take countermeasures against a possible leakage.

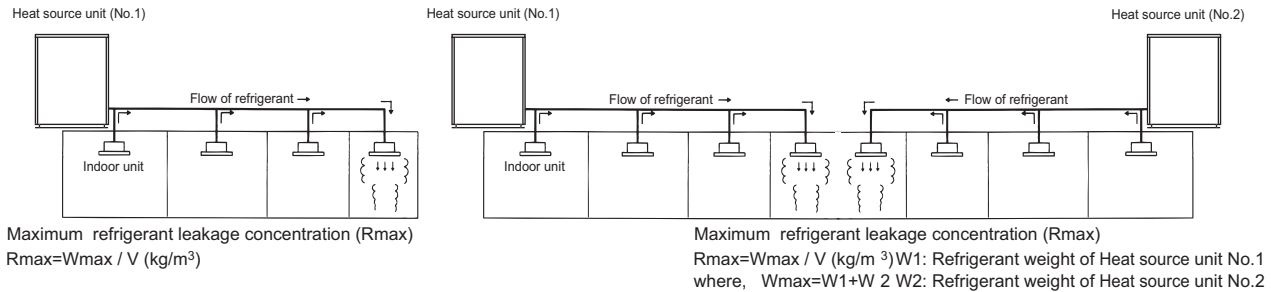

Fig. 6-1 The maximum refrigerant leakage concentration

### 6-2-1. Find the room capacity (V),

If a room having total opening area more than 0.15% of the floor area at a low position with another room/space, the two rooms/space are considered as one. The total space shall be added up.

### 6-2-2. Find the possible maximum leakage (Wmax) in the room. If a room has Indoor unit(s) from more than 1 Heat source unit, add up the refrigerant of the Heat source units.

### 6-2-3. Divide (Wmax) by (V) to get the maximum refrigerant leakage concentration (Rmax).

### 6-2-4. Find if there is any room in which the maximum refrigerant leakage concentration (Rmax) is over 0.44kg/m<sup>3</sup>.

If no, then the CITY MULTI is safe against refrigerant leakage.

If yes, following countermeasure is recommended to do at site.

Countermeasure 1: Let-out (making V bigger)

Design an opening of more than 0.15% of the floor area at a low position of the wall to let out the refrigerant whenever leaked.

e.g. make the upper and lower seams of door big enough.

Countermeasure 2: Smaller total charge (making Wmax smaller)

e.g. Avoid connecting more than 1 Heat source unit to one room.

e.g. Using smaller model size but more Heat source units.

e.g. Shorten the refrigerant piping as much as possible.

Countermeasure 3: Fresh air in from the ceiling (Ventilation)

As the density of the refrigerant is bigger than that of the air. Fresh air supply from the ceiling is better than air exhausting from the ceiling.

Fresh air supply solution refers to Fig. 6-2~4.

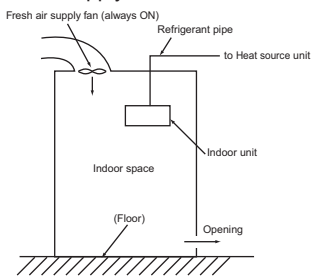

Fig.6-2. Fresh air supply always ON

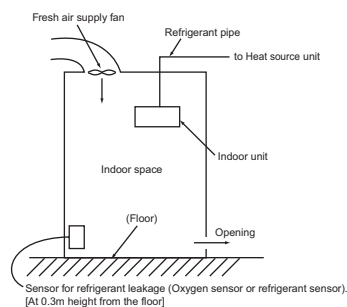

Fig.6-3. Fresh air supply upon sensor action

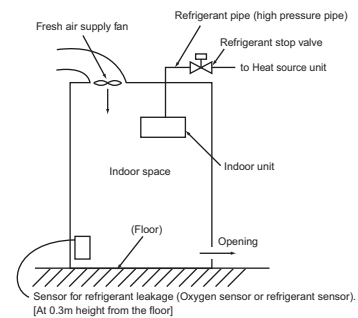

Fig.6-4. Fresh air supply and refrigerant shut-off upon sensor action

Note 1. Countermeasure 3 should be done in a proper way in which the fresh air supply shall be on whenever the leakage happens.

Note 2. In principle, MITSUBISHI ELECTRIC requires proper piping design, installation and air-tight testing after installation to avoid leakage happening.

In the area should earthquake happen, anti-vibration measures should be fully considered.

The piping should consider the extension due to the temperature variation.