

CITY MULTI SYSTEM DESIGN S SERIES

1. Electrical work.....	4 - 4
1-1.General cautions	4 - 4
1-2.Power supply for Indoor unit and Outdoor unit	4 - 5
1-3.Power cable specifications	4 - 7
1-4.Power supply examples.....	4 - 8
2. M-NET control.....	4 - 9
2-1.Transmission cable length limitation.....	4 - 9
2-2.Transmission cable specifications	4 - 10
2-3.System configuration restrictions.....	4 - 11
2-4.Address setting.....	4 - 15
3. Piping Design.....	4 - 25
3-1.R410A Piping material	4 - 25
3-2.Piping Design	4 - 25
3-3.Refrigerant charging calculation	4 - 27
4. Outdoor Installation.....	4 - 29
4-1.Requirement on installation site	4 - 29
4-2.Spacing.....	4 - 30
4-3.Piping direction	4 - 31

1-1. General cautions

- ① Follow ordinance of your governmental organization for technical standard related to electrical equipment, wiring regulations, and guidance of each electric power company.
- ② Wiring for control (hereinafter referred to as transmission cable) shall be (50mm[1-5/8in] or more) apart from power source wiring. (Do not insert transmission cable and power source wire in the same conduit.)
- ③ Be sure to provide designated grounding work to outdoor unit.
- ④ Give some allowance to wiring for electrical part box of indoor and outdoor units, because the box is sometimes removed at the time of service work.
- ⑤ Never connect 100V, 208~230V power source to terminal block of transmission cable. If connected, electrical parts will be damaged.
- ⑥ Use 2-core shield cable for transmission cable. If transmission cables of different systems are wired with the same multicore cable, the resultant poor transmitting and receiving will cause erroneous operations.
- ⑦ When extending the transmission line, make sure to extend the shield cable as well.

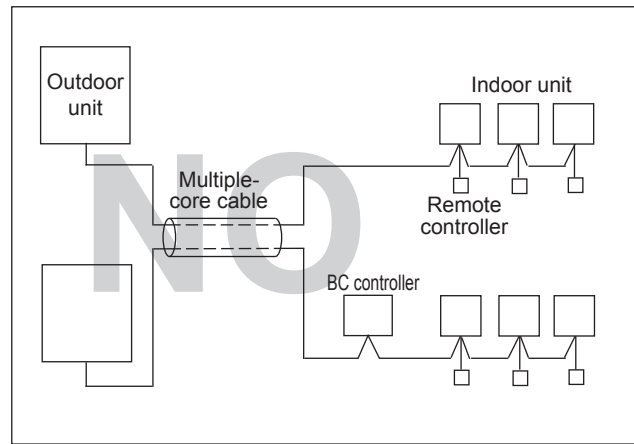
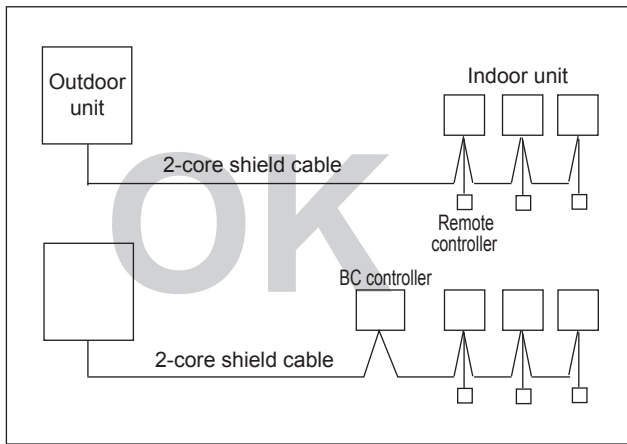

1-2. Power supply for Indoor unit and Outdoor unit

1-2-1. Electrical characteristics of Indoor unit

Symbols: MCA: Minimum Circuit Ampacity (=1.25xFLA) FLA: Full Load Amps

IFM: Indoor Fan Motor Output: Fan motor rated output

Model	Indoor Unit			IFM		
	Hz	Volts	Voltage range	MCA(A)	Output(kW)	FLA(A)
PLFY-P08NCMU-E	60Hz	208 / 230V	198 to 253V	0.29 / 0.29	0.015 / 0.015	0.23 / 0.23
PLFY-P12NCMU-E				0.35 / 0.35	0.020 / 0.020	0.28 / 0.28
PLFY-P15NCMU-E				0.35 / 0.35	0.020 / 0.020	0.28 / 0.28
PLFY-P08NBMU-E2				0.39 / 0.39	0.050 / 0.050	0.31 / 0.31
PLFY-P12NBMU-E2				0.39 / 0.39	0.050 / 0.050	0.31 / 0.31
PLFY-P15NBMU-E2				0.39 / 0.39	0.050 / 0.050	0.31 / 0.31
PLFY-P18NBMU-E2				0.42 / 0.42	0.050 / 0.050	0.33 / 0.33
PLFY-P24NBMU-E2				0.59 / 0.59	0.050 / 0.050	0.47 / 0.47
PLFY-P30NBMU-E2				0.63 / 0.63	0.050 / 0.050	0.50 / 0.50
PLFY-P36NBMU-E2				1.09 / 1.09	0.120 / 0.120	0.87 / 0.87
PMFY-P06NBMU-E	60Hz	208 / 230V	198 to 253V	0.25 / 0.25	0.028 / 0.028	0.20 / 0.20
PMFY-P08NBMU-E				0.25 / 0.25	0.028 / 0.028	0.20 / 0.20
PMFY-P12NBMU-E				0.26 / 0.26	0.028 / 0.028	0.21 / 0.21
PMFY-P15NBMU-E				0.33 / 0.33	0.028 / 0.028	0.26 / 0.26
PEFY-P06NMAU-E3	60Hz	208 / 230V	188 to 253V	1.05 / 1.05	0.085 / 0.085	0.84 / 0.84
PEFY-P08NMAU-E3				1.05 / 1.05	0.085 / 0.085	0.84 / 0.84
PEFY-P12NMAU-E3				1.20 / 1.20	0.085 / 0.085	0.96 / 0.96
PEFY-P15NMAU-E3				1.45 / 1.45	0.085 / 0.085	1.16 / 1.16
PEFY-P18NMAU-E3				1.56 / 1.56	0.085 / 0.085	1.25 / 1.25
PEFY-P24NMAU-E3				2.73 / 2.73	0.121 / 0.121	2.18 / 2.18
PEFY-P27NMAU-E3				2.73 / 2.73	0.121 / 0.121	2.18 / 2.18
PEFY-P30NMAU-E3				2.73 / 2.73	0.121 / 0.121	2.18 / 2.18
PEFY-P36NMAU-E3				3.32 / 3.32	0.244 / 0.244	2.66 / 2.66
PEFY-P48NMAU-E3				3.41 / 3.41	0.244 / 0.244	2.73 / 2.73
PEFY-P54NMAU-E3				3.31 / 3.31	0.244 / 0.244	2.65 / 2.65
PEFY-P06NMSU-E				60Hz	208 / 230V	188 to 253V
PEFY-P08NMSU-E	0.47 / 0.50	0.023 / 0.023	0.41 / 0.39			
PEFY-P12NMSU-E	0.68 / 0.74	0.032 / 0.032	0.46 / 0.43			
PEFY-P15NMSU-E	1.20 / 1.33	0.130 / 0.130	0.47 / 0.45			
PEFY-P18NMSU-E	1.20 / 1.33	0.130 / 0.130	0.64 / 0.60			
PEFY-P24NMSU-E	1.57 / 1.73	0.180 / 0.180	0.88 / 0.83			
PEFY-P15NMHU-E2	1.63 / 1.50	0.17	1.30 / 1.20			
PEFY-P18NMHU-E2	1.63 / 1.50	0.17	1.30 / 1.20			
PEFY-P24NMHU-E2	2.11 / 1.83	0.25	1.69 / 1.46			
PEFY-P27NMHU-E2	2.35 / 2.13	0.26	1.88 / 1.70			
PEFY-P30NMHU-E2	2.70 / 2.45	0.31	2.16 / 1.96			
PEFY-P36NMHU-E2	4.16 / 3.67	0.49	3.32 / 2.94			
PEFY-P48NMHU-E2	4.16 / 3.67	0.49	3.32 / 2.94			
PEFY-P54NMHU-E2	4.18 / 3.69	0.55	3.34 / 2.95			
PEFY-P72NMHSU-E	7.7	0.87	6.2			
PEFY-P96NMHSU-E	8.2	0.87	6.6			

Symbols: MCA: Minimum Circuit Ampacity (=1.25xFLA) FLA: Full Load Amps

IFM: Indoor Fan Motor

Output: Fan motor rated output

Model	Indoor Unit			IFM		
	Hz	Volts	Voltage range	MCA(A)	Output(kW)	FLA(A)
PCFY-P15NKMU-E	60Hz	208 / 230V	198 to 253V	0.44 / 0.44	0.090 / 0.090	0.35 / 0.35
PCFY-P24NKMU-E				0.52 / 0.52	0.095 / 0.095	0.41 / 0.41
PCFY-P30NKMU-E				1.22 / 1.22	0.160 / 0.160	0.97 / 0.97
PCFY-P36NKMU-E				1.22 / 1.22	0.160 / 0.160	0.97 / 0.97
PKFY-P06NBMU-E2	60Hz	208 / 230V	198 to 253V	0.19 / 0.19	0.008 / 0.008	0.15 / 0.15
PKFY-P08NHMU-E2				0.38 / 0.38	0.030 / 0.030	0.30 / 0.30
PKFY-P12NHMU-E2				0.38 / 0.38	0.030 / 0.030	0.30 / 0.30
PKFY-P15NHMU-E2				0.38 / 0.38	0.030 / 0.030	0.30 / 0.30
PKFY-P18NHMU-E2				0.38 / 0.38	0.030 / 0.030	0.30 / 0.30
PKFY-P24NKMU-E2				0.63 / 0.63	0.056 / 0.056	0.50 / 0.50
PKFY-P30NKMU-E2				0.63 / 0.63	0.056 / 0.056	0.50 / 0.50
PFFY-P06NEMU-E	60Hz	208 / 230V	188 to 253V	0.32 / 0.34	0.015 / 0.015	0.25 / 0.27
PFFY-P08NEMU-E				0.32 / 0.34	0.015 / 0.015	0.25 / 0.27
PFFY-P12NEMU-E				0.34 / 0.38	0.018 / 0.018	0.27 / 0.30
PFFY-P15NEMU-E				0.40 / 0.44	0.030 / 0.030	0.32 / 0.35
PFFY-P18NEMU-E				0.48 / 0.53	0.035 / 0.035	0.38 / 0.42
PFFY-P24NEMU-E				0.59 / 0.64	0.063 / 0.063	0.47 / 0.51
PFFY-P06NRMU-E	60Hz	208 / 230V	188 to 253V	0.32 / 0.34	0.015 / 0.015	0.25 / 0.27
PFFY-P08NRMU-E				0.32 / 0.34	0.015 / 0.015	0.25 / 0.27
PFFY-P12NRMU-E				0.34 / 0.38	0.018 / 0.018	0.27 / 0.30
PFFY-P15NRMU-E				0.40 / 0.44	0.030 / 0.030	0.32 / 0.35
PFFY-P18NRMU-E				0.48 / 0.53	0.035 / 0.035	0.38 / 0.42
PFFY-P24NRMU-E				0.59 / 0.64	0.063 / 0.063	0.47 / 0.51
PVFY-P12NAMU-E	60Hz	208 / 230V	188 to 253V	3.00 / 3.00	0.121 / 0.121	2.4 / 2.4
PVFY-P18NAMU-E				3.00 / 3.00	0.121 / 0.121	2.4 / 2.4
PVFY-P24NAMU-E				3.00 / 3.00	0.121 / 0.121	2.4 / 2.4
PVFY-P30NAMU-E				4.13 / 4.13	0.244 / 0.244	3.3 / 3.3
PVFY-P36NAMU-E				4.13 / 4.13	0.244 / 0.244	3.3 / 3.3
PVFY-P48NAMU-E				5.63 / 5.63	0.430 / 0.430	4.5 / 4.5
PVFY-P54NAMU-E				5.63 / 5.63	0.430 / 0.430	4.5 / 4.5

1-2-2. Electrical characteristics of Outdoor unit at cooling mode

Symbols: MCA : Minimum Circuit Ampacity

PUMY-P-NHMU, NKMU

SC: Starting Current RLA: Rated Load Amps

Model	Outdoor Units				Compressor		Fan	
	Volts/Hz	Voltage range	RLA (A)	MCA (A)	Max. Fuse (A)	Output (kW)	SC (A)	Output (kW)
PUMY-P36NHMU(-BS)	208V / 60Hz	198 to 228V	24.0	26	40	2.2	14	0.086 x 2
	230V / 60Hz	207 to 253V	21.7	26	40			
PUMY-P48NHMU(-BS)	208V / 60Hz	198 to 228V	24.0	26	40	2.4	14	0.086 x 2
	230V / 60Hz	207 to 253V	21.7	26	40			
PUMY-P60NKMU(-BS)	208V / 60Hz	198 to 228V	19.9	35	42	3.0	7	0.16 x 2
	230V / 60Hz	207 to 253V	18.0	35	42			

1-3. Power cable specifications

Thickness of wire for main power supply, capacities of the switch and system impedance

1-phase 2-wire, 208V, 60Hz		Minimum wire thickness (mm ² /AWG)			Switch (A)		Breaker for wiring (NFB)	Breaker for current leakage
		Main cable	Branch	Ground	Capacity	Fuse		
PUMY-P-NHMU	P36, P48	5.3/10	-	5.3/10	30	30	30	30A 30mA 0.1sec. or less
PUMY-P-NKMU	P60	8.4/8	-	8.4/8	40	40	40	40A 30mA 0.1sec. or less
Total operating current of the indoor unit	F0 = 15 or less *1	2.1/14	2.1/14	2.1/14	15	15	15	15A current sensitivity *2
	F0 = 20 or less *1	3.3/12	3.3/12	3.3/12	20	20	20	20A current sensitivity *2
	F0 = 30 or less *1	5.3/10	5.3/10	5.3/10	30	30	30	30A current sensitivity *2

1-phase 2-wire, 230V, 60Hz		Minimum wire thickness (mm ² /AWG)			Switch (A)		Breaker for wiring (NFB)	Breaker for current leakage
		Main cable	Branch	Ground	Capacity	Fuse		
PUMY-P-NHMU	P36, P48	5.3/10	-	5.3/10	30	30	30	30A 30mA 0.1sec. or less
PUMY-P-NKMU	P60	8.4/8	-	8.4/8	40	40	40	40A 30mA 0.1sec. or less
Total operating current of the indoor unit	F0 = 15 or less *1	2.1/14	2.1/14	2.1/14	15	15	15	15A current sensitivity *2
	F0 = 20 or less *1	3.3/12	3.3/12	3.3/12	20	20	20	20A current sensitivity *2
	F0 = 30 or less *1	5.3/10	5.3/10	5.3/10	30	30	30	30A current sensitivity *2

*1 Please take the larger of F1 or F2 as the value for F0.

F1 = Total operating maximum current of the indoor units × 1.2

F2 = {V1 × (Quantity of Type1)/C} + {V1 × (Quantity of Type2)/C} + {V1 × (Quantity of Type3)/C} + {V1 × (Quantity of Others)/C}

Indoor unit		V1	V2
Type1	PLFY-NBMU, PMFY-NBMU, PEFY-NMSU, PCFY-NKMU, PKFY-NHMU, PKFY-NKMU	18.6	2.4
Type2	PEFY-NMAU	38	1.6
Type3	PEFY-NMHSU	13.8	4.8
Others	Other indoor unit	0	0

C : Multiple of tripping current at tripping time 0.01s

Please pick up "C" from the tripping characteristic of the breaker.

<Example of "F2" calculation>

*Condition PEFY-NMSU × 4 + PEFY-NMAU × 1, C = 8 (refer to right sample chart)

F2 = 18.6 × 4/8 + 38 × 1/8

= 14.05

→ 16 A breaker (Tripping current = 8 × 16 A at 0.01s)

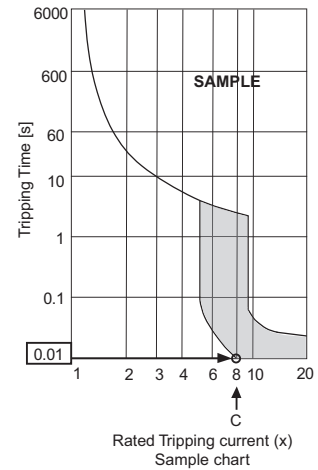

*2 Current sensitivity is calculated using the following formula.

G1 = (V2 × Quantity of Type1) + (V2 × Quantity of Type2) + (V2 × Quantity of Type3) + (V2 × Quantity of Others) + (V3 × Wire length [km])

G1	Current sensitivity
30 or less	30 mA 0.1sec or less
100 or less	100 mA 0.1sec or less

Wire thickness	V3
1.5 mm ²	48
2.5 mm ²	56
4.0 mm ²	66

1. Use a separate power supply for the outdoor unit and indoor unit.
2. Bear in mind ambient conditions (ambient temperature, direct sunlight, rain water, etc.) when proceeding with the wiring and connections.
3. The wire size is the minimum value for metal conduit wiring. The power cord size should be 1 rank thicker consideration of voltage drops. Make sure the power-supply voltage does not drop more than 10%. Make sure that the voltage imbalance between the phases is 2% or less.
4. Specific wiring requirements should adhere to the wiring regulations of the region.
5. Power supply cords of parts of appliances for outdoor use shall not be lighter than polychloroprene sheathed flexible cord (design 245 IEC57). For example, use wiring such as YZW.
6. A switch with at least 3 mm [1/8 in] contact separation in each pole shall be provided by the Air conditioner installation.

⚠ WARNING

- ◆ Be sure to use specified wires to connect so that no external force is imparted to terminal connections. If connections are not fixed firmly, it may cause heating or fire.
- ◆ Be sure to use the appropriate type of overcurrent protection switch. Note that generated overcurrent may include some amount of direct current.

⚠ CAUTION

- ◆ The breakers for current leakage should support Inverter circuit. (e.g. Mitsubishi Electric's NV-C series or equivalent). If no earth leakage breaker is installed, it may cause an electric shock.
- ◆ Breakers for current leakage should combine using of switch.
- ◆ Do not use anything other than a breaker with the correct capacity. Using a breaker of too large capacity may cause malfunction or fire.
- ◆ If a large electric current flows due to malfunction or faulty wiring, earth-leakage breakers on the unit side and on the upstream side of the power supply system may both operate. Depending on the importance of the system, separate the power supply system or take protective coordination of breakers.

1-4. Power supply examples

The local standards and/or regulations is applicable at a higher priority.

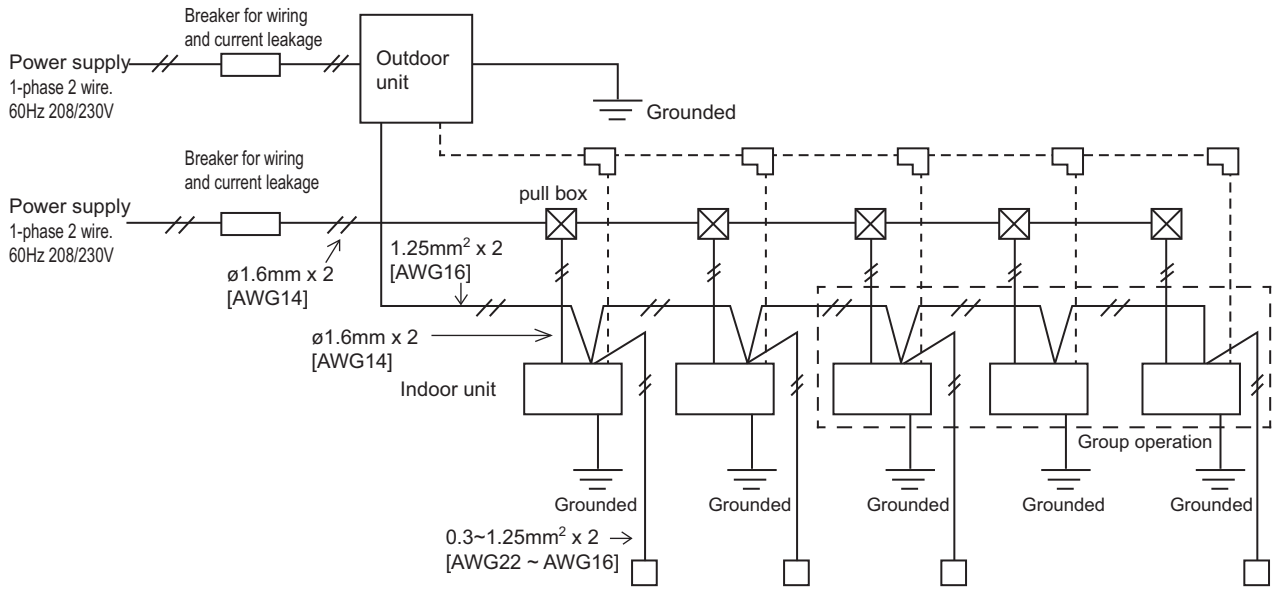

2-1. Transmission cable length limitation

2-1-1. Using MA Remote controller

MA remote controller refers to Simple MA remote controller and wireless remote controller.

Applicable to Outdoor as follows Long transmission cable causes voltage down, therefore, the length limitation should be obeyed to secure proper transmission.

PUMY-P-NHMU	Max. length via Outdoor (M-NET cable)	$L1+L2+L3, L1+L2+L4+L5, L3+L4+L5$	$\leq 500\text{m}[1640\text{ft}]$	1.25mm ² [AWG16] or thicker
PUMY-P-NKMU	Max. length to Outdoor (M-NET cable)	$L1, L3, L2+L4, L5$	$\leq 200\text{m}[656\text{ft}]$	1.25mm ² [AWG16] or thicker
	Max. length from MA to Indoor for each group	$a1+a2, a1+a2+a3+a4$	$\leq 200\text{m}[656\text{ft}]$	-
	24VDC to AG-150A-A	n	$\leq 50\text{m}[164\text{ft}]$	0.75-2.0 mm ² [AWG18-14]

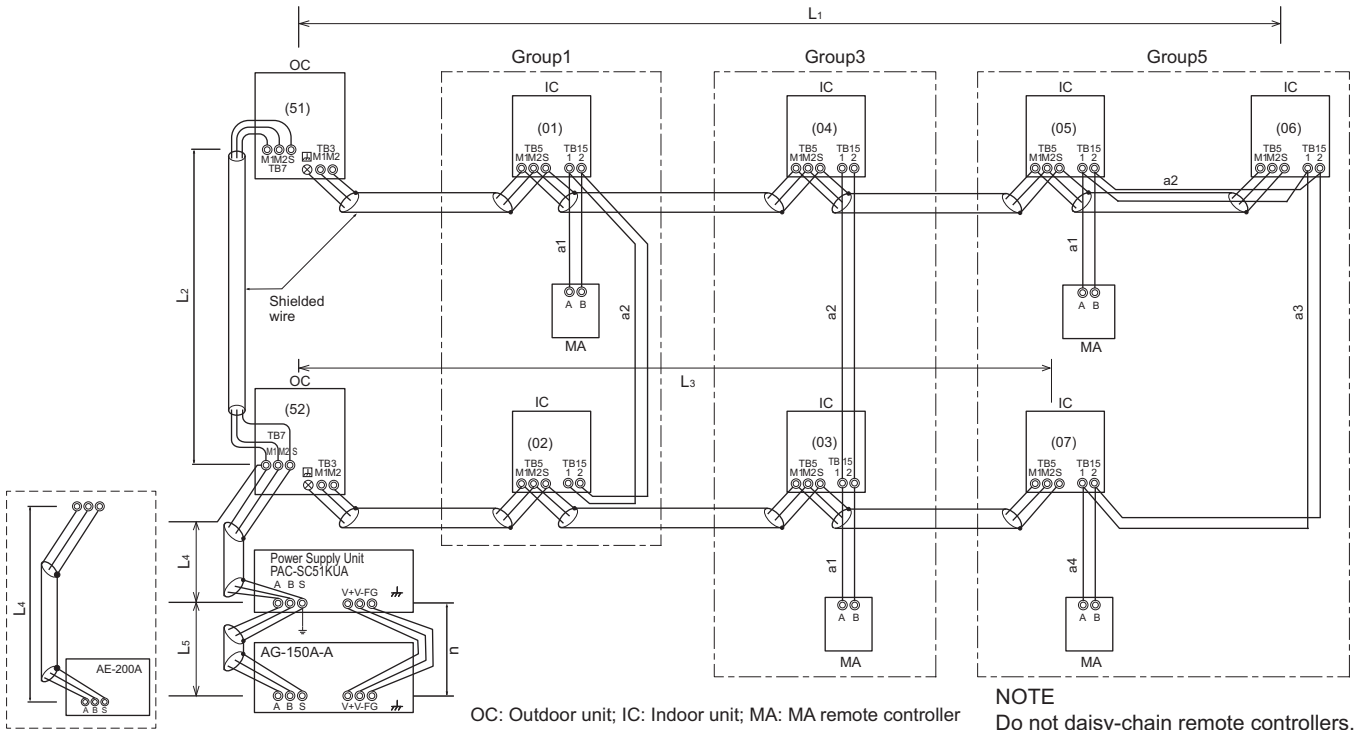

2-1-2. Using ME Remote controller

ME remote controller refers to Smart ME controller.

Applicable to Outdoor as follows Long transmission cable causes voltage down, therefore, the length limitation should be obeyed to secure proper transmission.

PUMY-P-NHMU	Max. length via Outdoor (M-NET cable)	$L1+L2+L3+L4, L1+L2+L6+L7, L1+L2+L3+L5, L3+L4+L6+L7, L3+L5+L6+L7, L4+L5$	$\leq 500\text{m}[1640\text{ft}]$	1.25mm ² [AWG16] or thicker
PUMY-P-NKMU	Max. length to Outdoor (M-NET cable)	$L1, L3+L4, L2+L6, L7, L3+L5$	$\leq 200\text{m}[656\text{ft}]$	1.25mm ² [AWG16] or thicker
	Max. length from ME to Indoor	$e1, e2, e3, e4$	$\leq 10\text{m}[32\text{ft}]$ *1	0.3-1.25 mm ² [AWG22-16] *1
	24VDC to AG-150A-A	n	$\leq 50\text{m}[164\text{ft}]$	0.75-2.0 mm ² [AWG18-14]

*1. If the length from ME to Indoor exceed 10m, use 1.25 mm² [AWG16] shielded cable, but the total length should be counted into Max. length via Outdoor.

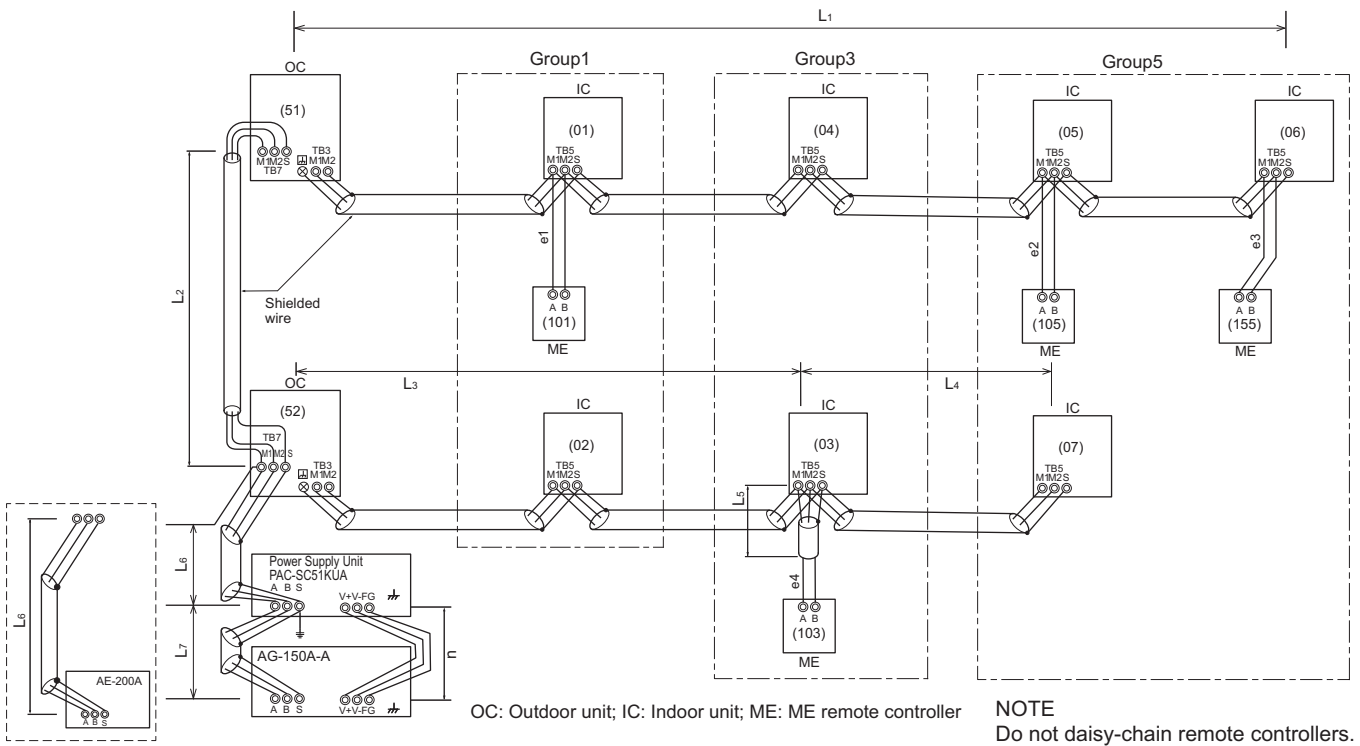

2-2. Transmission cable specifications

	Transmission cables (Li)	ME Remote controller cables	MA Remote controller cables
Type of cable	Shielding wire (2-core) CVVS, CPEVS or MVVS	Sheathed 2-core cable (unshielded) CVV	
Cable size	More than 1.25mm ² [AWG16]	0.3~1.25mm ² [AWG22~16]	0.3~1.25mm ² [AWG22~16]*1
Remarks	—	When 10m [32ft] is exceeded, use cables with the same specification as transmission cables.	Max length : 200m [656ft]

*1 To wire PAC-YT53CRAU, use a wire with a diameter of 0.3 mm² [AWG22]

CVVS, MVVS: PVC insulated PVC sheathed shielded control cable
CPEVS: PE insulated PVC sheathed shielded communication cable
CVV: PVC insulated PVC sheathed control cable

2-3. System configuration restrictions

2-3-1. Common restrictions for the CITYMULTI system

For each Outdoor/Heat source unit, the maximum connectable quantity of Indoor unit is specified at its Specifications table.

- A) 1 Group of Indoor units can have 1-16 Indoor units;
- B) Maximum 2 remote controllers for 1 group;
 - *MA/ME remote controllers cannot be present together in 1group.
 - *To wire PAC-YT53CRAU, use a wire with a diameter of 0.3 mm² [AWG22]
- C) 1 LOSSNAY unit can interlock maximum 16 Indoor units; 1 Indoor unit can interlock only 1 LOSSNAY unit.
- D) Maximum 3 System controllers are connectable when connecting to TB3 of the Outdoor/Heat source unit.
- E) Maximum 6 System controllers are connectable when connecting to TB7 of the Outdoor/Heat source unit, if the transmission power is supplied by the Outdoor/Heat source unit.
 - (Not applicable to the PUMY model and PUHY/PURY-TLMU/TKMU model)
- F) 4 System controllers or more are connectable when connecting to TB7 of the Outdoor/Heat source unit, if the transmission power is supplied by the power supply unit PAC-SC51KUA. Details refer to 2-3-3-C.
 - *System controller connected as described in D) and E) would have a risk that the failure of connected Outdoor/Heat source unit would stop power supply to the System controller.

2-3-2. Ensuring proper communication power and the number of connected units for M-NET

In order to ensure proper communication among Outdoor/Heat source unit, Indoor unit, LOSSNAY, and Controllers, the transmission power situation for the M-NET should be observed. In some cases, Transmission booster should be used. Taking the power consumption of Indoor unit sized P06-P54 as 1, the equivalent power consumption or supply of others are listed at Table 1 and Table 2.

Both the transmission line for centralized controller and indoor-outdoor transmission line must meet the conditions listed below. (Both conditions a) and b) must be met.)

- a) [Total equivalent power consumption] ≤ [The equivalent power supply]
- b) [Total equivalent number of units] ≤ [40]

Table 1 The equivalent power consumption and the equivalent number of units

Category	Model	The equivalent power consumption	The equivalent number of units
Indoor unit	Sized P06-P54	1	1
	Sized P72, P96	2	2
BC controller	CMB	2	1
PWFY	P36NMU-E-BU	6	1
	P36NMU-E2-AU	1	1
	P72NMU-E2-AU	5	1
MA remote controller/LOSSNAY	PAC-YT53CRAU PAR-FA32MA LGH-F-RX5-E1 PZ-60DR-E PZ-41SLB PZ-52SF	0	0
ME remote controller	PAR-U01MEDU PAC-IF01AHC-J	0.5	1
System controller	AE-200A AE-50A EW-50A	0	0
	AG-150A-A EB-50GU-A	0.5	1
	TC-24B	1.5	5
	PAC-YG60MCA PAC-YG66DCA PAC-YG63MCA	0.25	1
ON/OFF controller	PAC-YT40ANRA	1	1
MN converter	CMS-MNG-E	2	1
Outdoor/Heat source unit	TB7 power consumption	0	0
M-NET adapter	MAC-333IF-E	0	0
	PAC-IF01MNT-E	1	2

Table 2 The equivalent power supply

Category	Model	The equivalent power supply
Transmission Booster	PAC-SF46EPA	25
Power supply unit	PAC-SC51KUA	5
Expansion controller	PAC-YG50ECA	6
BM ADAPTER	BAC-HD150	6
System controller	AE-200A/AE-50A	0 *1
	EW-50A	1.5 *1
Outdoor/Heat source unit	Connector TB3 and TB7 total *	32 (except S series)/12 (S series)
	Connector TB7 only	6 (except S series and TLMU/TKMU)
	Connector TB7 only (TLMU/TKMU)	0

*If PAC-SC51KUA is used to supply power at TB7 side, no power supply need from Outdoor/Heat source unit at TB7, Connector TB3 itself will therefore have 32. Not applicable to the PUMY model.

*1 AE-200A/AE-50A/EW-50A has a built-in function to supply power to the M-NET transmission line. The amount of power that an AE-200A or an AE-50A can supply is equivalent to the power required by an MN converter (CMS-MNG-E) that is used for maintenance. An MN converter is connectable to EW-50A only when the equivalent power consumption is less than 1.5.

With the equivalent power consumption values and the equivalent number of units in Table 1 and Table 2, PAC-SF46EPA can be designed into the air-conditioner system to ensure proper system communication according to (A), (B), (C).

- (A) Firstly, count from TB3 at TB3 side the total equivalent number of units of Indoor units, ME remote controller, and System controllers. If the total equivalent number of units reaches 40, a PAC-SF46EPA should be set. In this case, Indoor units sized P72 and 96 are counted as 2, TC-24B is counted as 5, but MA remote controller(s), PZ-60DR-E, PZ-41SLB, and PZ-52SF are NOT counted.
- (B) Secondly, count from TB7 side to TB3 side the total transmission power consumption. If the total power consumption reaches 32, a PAC-SF46EPA should be set. Yet, if a PAC-SC51KUA or another controller with a built-in power supply, such as PAC-YG50ECA, is used to supply power at TB7 side, count from TB3 side only.
- (C) Thirdly, count from TB7 at TB7 side the total transmission power consumption, If the total power consumption reaches 6, a PAC-SF46EPA should be set. Also, count from TB7 at TB7 side the total equivalent number of units of System controllers, and so on. If the total equivalent number of units reaches 40, a PAC-SF46EPA should be set.

■ System example

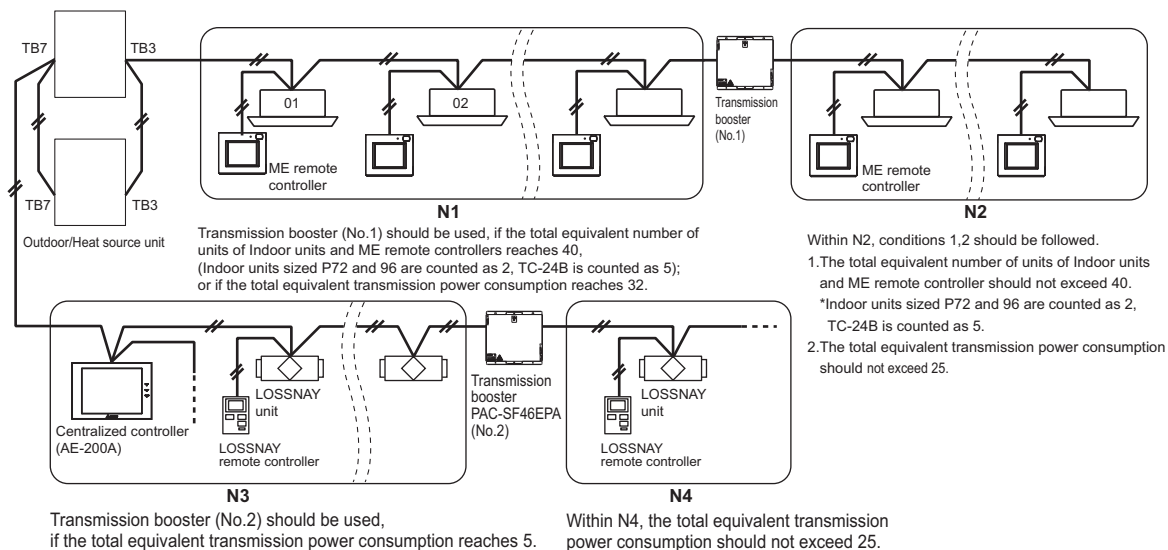

2-3-3. Ensuring proper power supply to System controller

The power to System controller (excluding AE-200A, AE-50A, EW-50A, BAC-HD150, LM-AP) is supplied via M-NET transmission line. M-NET transmission line at TB7 side is called Centralized control transmission line while one at TB3 side is called Indoor-Outdoor/Heat source transmission line. There are 3 ways to supply power to the System controller .

- A) Connecting to TB3 of the Outdoor/Heat source unit and receiving power from the Outdoor/Heat source unit.
- B) Connecting to TB7 of the Outdoor/Heat source unit and receiving power from the Outdoor/Heat source unit.

(Not applicable to the PUMY model and PUHY/PURY-TLMU/TKMU model)

- C) Connecting to TB7 of the Outdoor/Heat source unit but receiving power from power supply unit PAC-SC51KUA.

* System controllers (AE-200A, AE-50A, EW-50A, BAC-HD150, LM-AP) have a built-in function to supply power to the M-NET transmission lines, so no power needs to be supplied to the Outdoor/Heat source units or from PAC-SC51KUA.

2-3-3-A. When connecting to TB3 of the Outdoor/Heat source unit and receiving power from the Outdoor/Heat source unit.

Maximum 3 System controllers can be connected to TB3. If there is more than 1 Outdoor/Heat source unit, it is necessary to replace power supply switch connector CN41 with CN40 on one Outdoor/Heat source unit.

Fig. 2-3-3-A

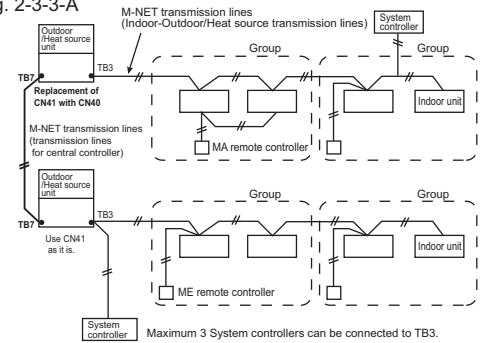

Maximum 3 System controllers can be connected to TB3.

2-3-3-B. When connecting to TB7 of the Outdoor/Heat source unit and receiving power from the Outdoor/Heat source unit. (Not applicable to the PUMY model and PUHY/PURY-TLMU/TKMU model)

Maximum 6 System controllers can be connected to TB7 and receiving power from the Outdoor/Heat source unit. (Not applicable to the PUMY model and PUHY/PURY-TLMU/TKMU model) It is necessary to replace power supply switch connector CN41 with CN40 on one Outdoor/Heat source unit.

Fig. 2-3-3-B

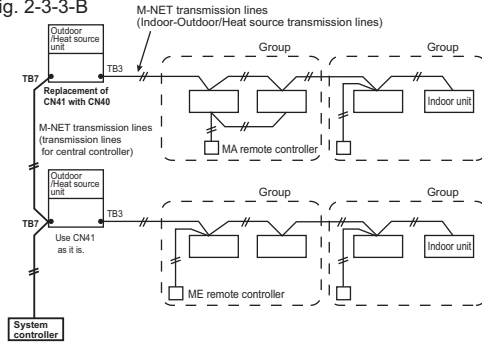

Note (only for PUHY/PURY model)

- When YLMU/YKMU Outdoor unit model is used, the male power supply connector can be connected to CN40, and the System controller can be connected to TB7 side.
- When the male power supply connector is connected from TLMU/TKMU Outdoor unit to CN40, the power is supplied to TB7 side even when the main power of the TLMU/TKMU outdoor unit is switched off, and the System controller may store an error in the error history and emit an alarm signal.
- If only LOSSNAY units or outdoor units in different refrigerant circuits are connected to TB7 side, the male power supply connector can be connected from TLMU/TKMU outdoor unit to CN40.

2-3-3-C. When connecting to TB7 of the Outdoor/Heat source unit but receiving power from PAC-SC51KUA.

When using PAC-SC51KUA to supply transmission power, the power supply connector CN41 on the Outdoor/Heat source units should be kept as it is. It is also a factory setting. 1 PAC-SC51KUA supports maximum 1 AG-150A-A or 1 EB-50GU-A unit due to the limited power 24VDC at its TB3. However, 1 PAC-SC51KUA supplies transmission power at its TB2 equal to 5 Indoor units, which is referable at Table 2. If PZ-52SF, System controller, ON/OFF controller connected to TB7 consume transmission power more than 5 (Indoor units), Transmission booster PAC-SF46EPA is needed. PAC-SF46EPA supplies transmission power equal to 25 Indoor units.

Fig. 2-3-3-C

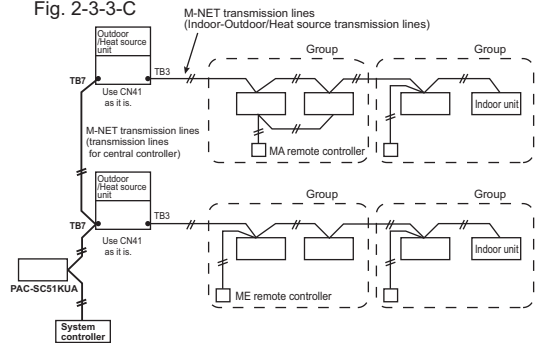

CAUTION

- AG-150A-A/EB-50GU-A*1 are recommended to connect to TB7 because it performs back-up to a number of data. In an air conditioner system has more than 1 Outdoor/Heat source units, AG-150A-A/EB-50GU-A receiving transmission power through TB3 or TB7 on one of the Outdoor/Heat source units would have a risk that the connected Outdoor/Heat source unit failure would stop power supply to AG-150A-A/EB-50GU-A and disrupt the whole system. When applying apportioned electric power function, AG-150A-A/EB-50GU-A are necessary to connected to TB7 and has its own power supply unit PAC-SC51KUA. Note: Power supply unit PAC-SC51KUA is for AG-150A-A/EB-50GU-A. *1: AG-150A-A is an example model of system controllers.
- How to connect system controllers (AE-200A, AE-50A, EW-50A, BAC-HD150, LM-AP) to a given system System controllers (AE-200A, AE-50A, EW-50A, BAC-HD150, LM-AP) have a built-in function to supply power to the M-NET transmission lines, so no power needs to be supplied to the M-NET transmission lines from the Outdoor/Heat source units or from PAC-SC51KUA. Leave the power supply connector on the Outdoor/Heat source unit connected to CN41 as it is. Refer to 2-3-2 for information about the power-supply capacity of each system controller (EW-50A, BAC-HD150, LM-AP) to the low-level system controllers.

Fig. 2-3-3-D

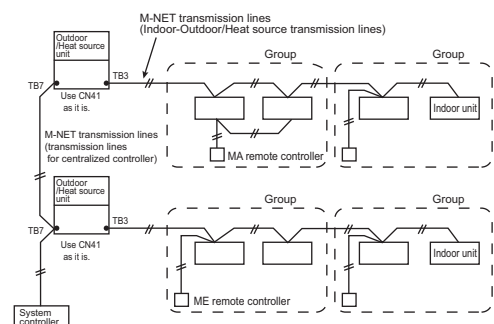

2-3-4. Power supply to LM-AP

1-phase 208-230V AC power supply is needed.

The power supply unit PAC-SC51KUA is not necessary when connecting only the LM-AP. Yet, make sure to change the power supply changeover connector CN41 to CN40 on the LM-AP.

2-3-5. Power supply to expansion controller

1-phase 100-240VAC power supply is needed.

The power supply unit PAC-SC51KUA is not necessary.

The expansion controller supplies power through TB3, which equals 6 indoor units. (refer to Table 2)

2-3-6. Power supply to BM ADAPTER

1-phase 100-240VAC power supply is needed.

The power supply unit PAC-SC51KUA is not necessary when only BM ADAPTER is connected.

Yet, make sure to move the power jumper from CN41 to CN40 on the BM ADAPTER.

2-3-7. Power supply to AE-200A/AE-50A/EW-50A

1-phase 100-240VAC power supply is needed.

The power supply unit PAC-SC51KUA is not necessary when connecting only the AE-200A/AE-50A/EW-50A.

2-4. Address setting

2-4-1. Switch operation

In order to constitute CITY MULTI in a complete system, switch operation for setting the unit address No. and connection No. is required.

- ① Address No. of outdoor unit, indoor unit and ME remote controller.
The address No. is set at the address setting board.
In the case of R2 system, it is necessary to set the same No. at the branch No. switch of indoor unit as that of the BC controller connected. (When connecting two or more branches, use the lowest branch No.)

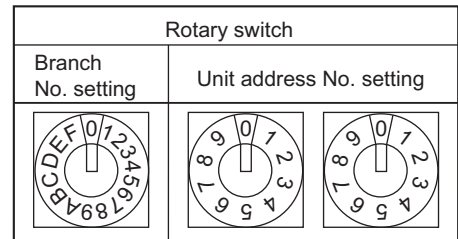

② Caution for switch operations

- Be sure to shut off power source before switch setting. If operated with power source on, switch can not operate properly.
- No units with identical unit address shall exist in one whole air conditioner system. If set erroneously, the system can not operate.

③ MA remote controller

- When connecting only one remote controller to one group, it is always the main remote controller. When connecting two remote controllers to one group, set one remote controller as the main remote controller and the other as the sub remote controller.
- The factory setting is "Main".

PAC-YT53CRAU

Setting the dip switches

There are switches on the back of the top case. Remote controller Main/Sub and other function settings are performed using these switches. Ordinarily, only change the Main/Sub setting of SW1. (The factory settings are ON for SW1, 3, and 4 and OFF for SW2.)

SW No	SW contents Main	ON	OFF	Comment
1	Remote controller Main/Sub setting	Main	Sub	Set one of the two remote controllers at one group to "ON".
2	Temperature display units setting	Celsius	Fahrenheit	When the temperature is displayed in [Fahrenheit], set to "OFF".
3	Cooling/heating display in AUTO mode	Yes	No	When you do not want to display "Cooling" and "Heating" in the AUTO mode, set to "OFF".
4	Indoor temperature display	Yes	No	When you do not want to display the indoor temperature, set to "OFF".

2-4-2. Rule of setting address

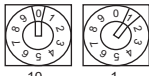
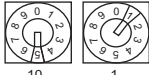
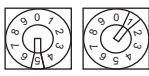
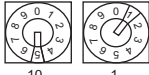
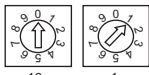
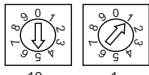
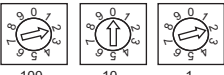
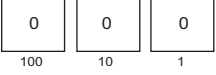
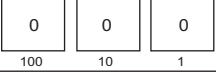
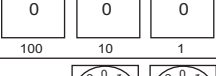
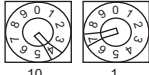
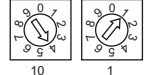
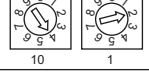
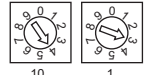
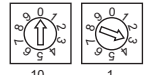
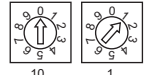
Unit	Address setting	Example	Note
Indoor unit System control interface (MAC-333IF-E) A-M converter (PAC-IF01MNT-E)	01 ~ 50		Use the most recent address within the same group of indoor units. Make the indoor units address connected to the BC controller (Sub) larger than the indoor units address connected to the BC controller (Main). If applicable, set the sub BC controllers in a PURY system in the following order: (1) Indoor unit to be connected to the BC controller (Main) (2) Indoor unit to be connected to the BC controller (No.1 Sub) (3) Indoor unit to be connected to the BC controller (No.2 Sub) Set the address so that (1)<(2)<(3)
Outdoor unit	51 ~ 99, 100 (Note1)		The smallest address of indoor unit in same refrigerant system + 50 Assign sequential address numbers to the outdoor units in one refrigerant circuit system. OC and OS are automatically detected. (Note 2) *Please reset one of them to an address between 51 and 99 when two addresses overlap. *The address automatically becomes "100" if it is set as "01~ 50"
BC controller (Main)	52 ~ 99, 100		The address of outdoor unit + 1 *Please reset one of them to an address between 51 and 99 when two addresses overlap. *The address automatically becomes "100" if it is set as "01~ 50"
BC controller (Sub)	52 ~ 99, 100		Lowest address within the indoor units connected to the BC controller (Sub) plus 50.
Local remote controller	ME, LOSSNAY Remote controller (Main)	1 Fixed 	The smallest address of indoor unit in the group + 100 *The place of "100" is fixed to "1"
	ME, LOSSNAY Remote controller (Sub)	1 Fixed 	The address of main remote controller + 50 *The address automatically becomes "200" if it is set as "00"
System controller	ON/OFF remote controller		The smallest group No. to be managed + 200 * The smallest group No. to be managed is changeable.
	AE-200A/AE-50A AG-150A-A EB-50GU-A EW-50A TC-24B	000, 201 ~ 250 	* TC-24B cannot be set to "000".
	PAC-YG50ECA	000, 201 ~ 250 	* Settings are made on the initial screen of AG-150A-A.
	BAC-HD150	000, 201 ~ 250 	* Settings are made with setting tool of BM ADAPTER.
	LMAP04U-E	201 ~ 250 2 Fixed 	
PI, AI, DIDO	PAC-YG60MCA		
	PAC-YG63MCA		
	PAC-YG66DCA		
LOSSNAY	01 ~ 50		After setting the addresses of all the indoor units, assign an arbitrary address.
PAC-IF01AHC-J	201 ~ 250	2 Fixed 	

Note1: To set the address to "100", set it to "50"

Note2: Outdoor units OC and OS in one refrigerant circuit system are automatically detected.

OC and OS are ranked in descending order of capacity. If units are the same capacity, they are ranked in ascending order of their address.

2-4-3. System example

Factory setting

Original switch setting of the outdoors, indoors, controllers, LM-AP, and BM ADAPTER at shipment is as follows.

- Outdoor unit : Address: 00, CN41: ON (Jumper), DipSW2-1: OFF
- Indoor unit : Address: 00
- ME remote controller : Address: 101
- LM-AP : Address: 247, CN41: ON (Jumper), DipSW1-2: OFF
- BM ADAPTER : Address: 000, CN41: ON (Jumper)

2-4-3-1. Example : Basic (No address setting)

MA R/C: PAC-YT53CRAU

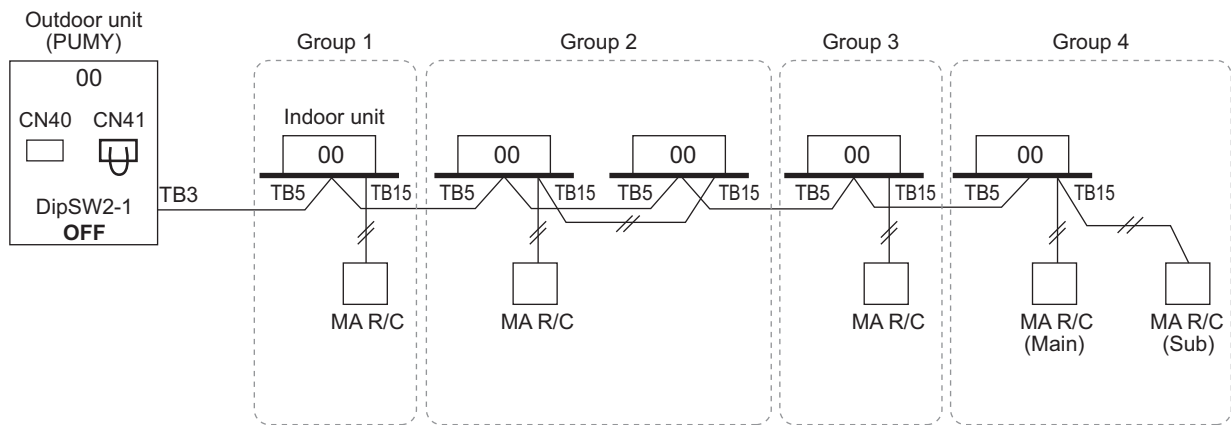

2-4-3-2. Example : Basic, Sub/main ME remote controller

Main R/C: PAR-U01MEDU
Sub R/C: PAR-U01MEDU

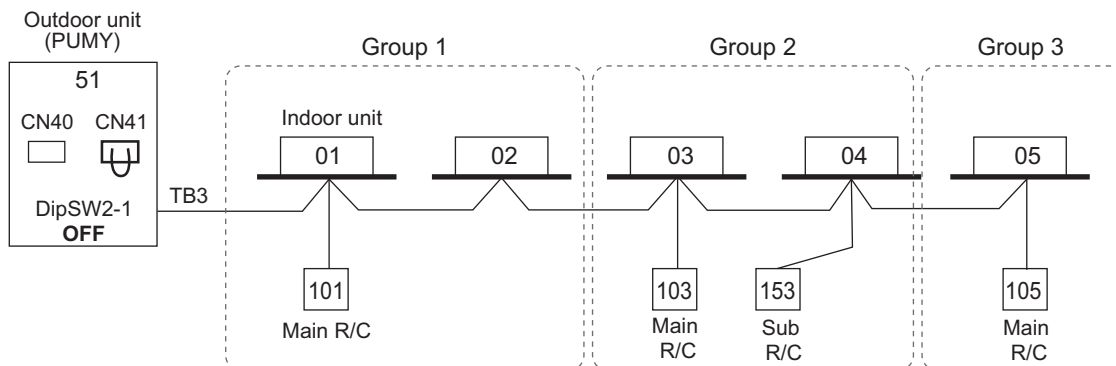

2-4-3-3. Example : AG-150A-A, AE-200A, TB7

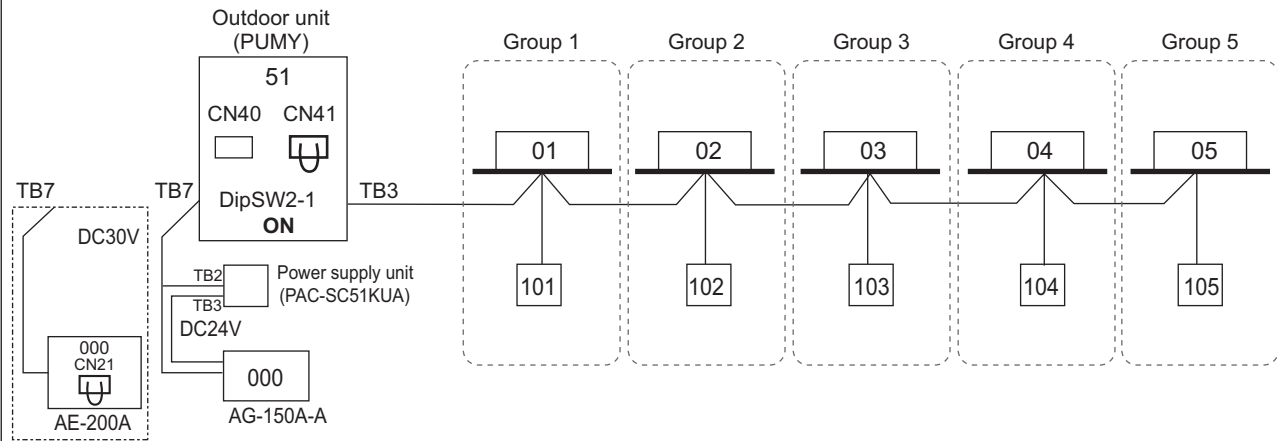

NOTE

- It is necessary to turn on the DipSW 2-1 on the outdoor unit control board when the central controller is connected.

2-4-3-4. Example : Grouping in different refrigerant system

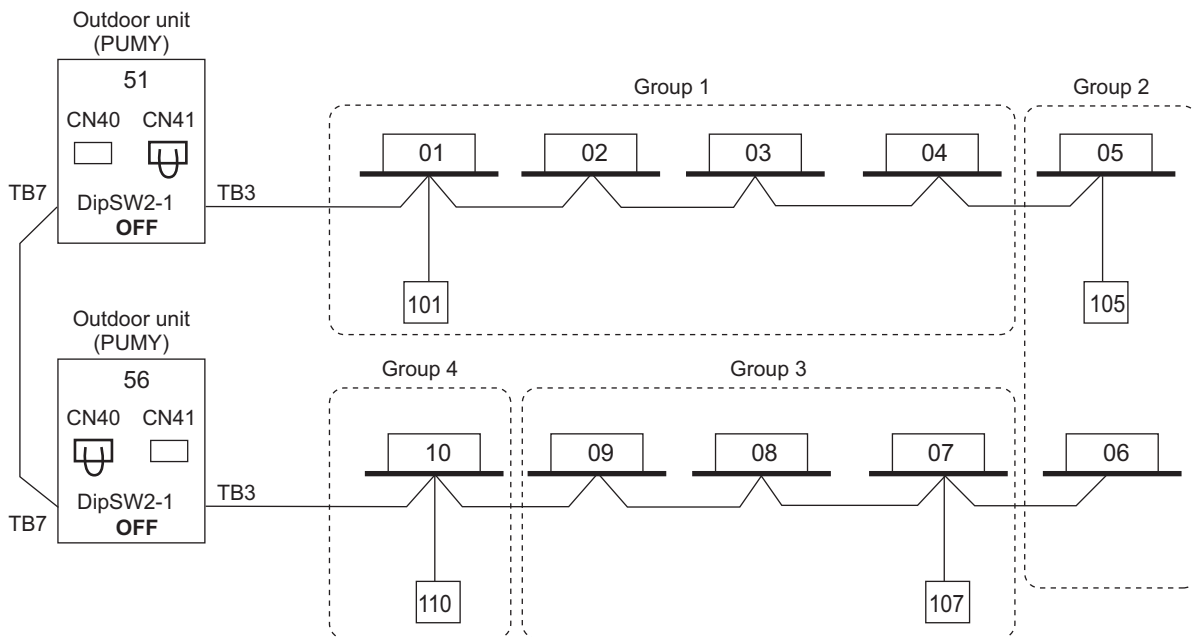

NOTE

- It is necessary to change the connector to CN40 on the outdoor unit control board (only one Outdoor unit) when the group is set between other refrigerant systems.
- It is necessary to set on the remote controller by manual when group sets on the different refrigerant system. Please refer to remote controller installation manual.

2-4-3-5. Example: 2 Outdoor unit, AG-150A-A, AE-200A, MA

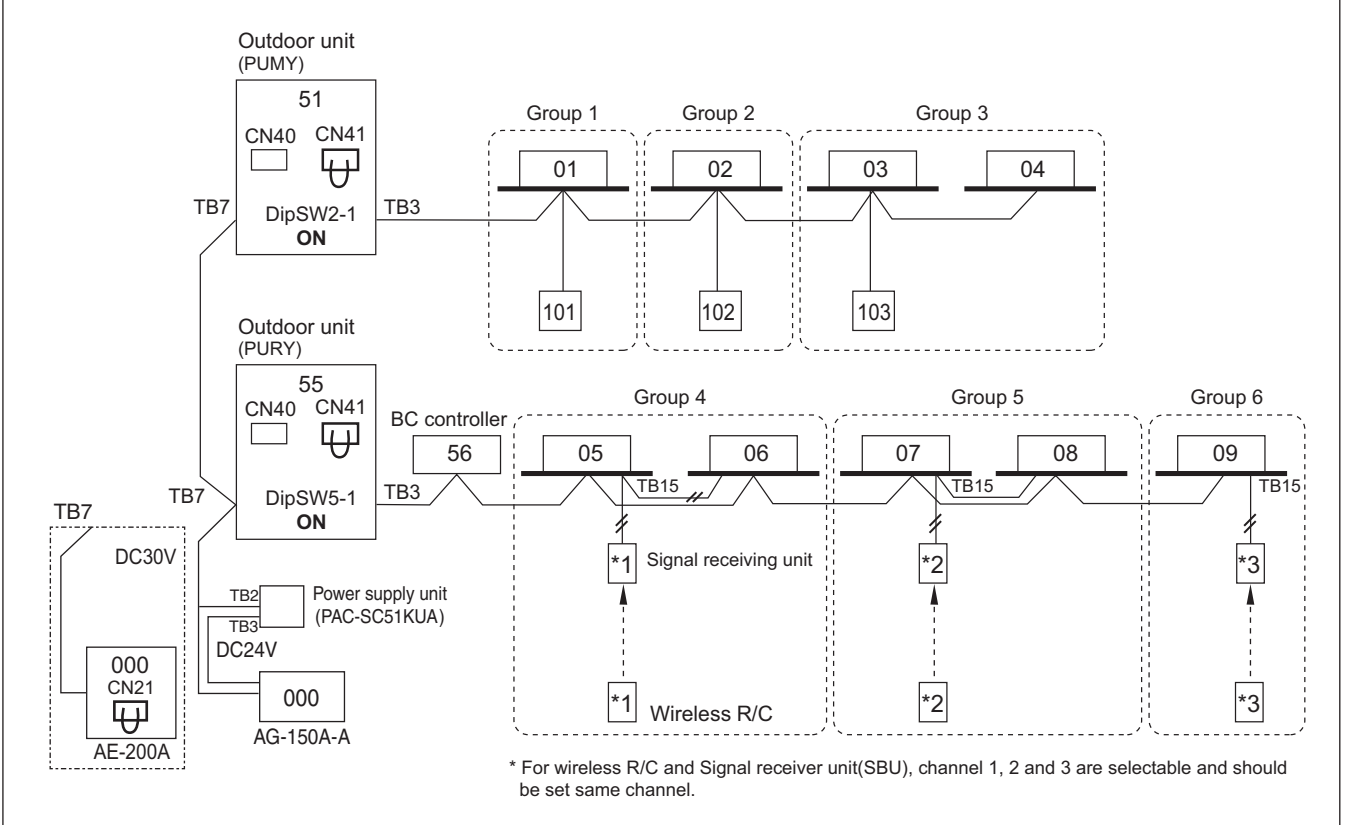

2-4-3-6. Example: TG-2000A(*1)+AE-200A/AE-50A/EW-50A

AE-200A can control max. 50 indoor units;
 TG-2000A can control max. 40 of AE-200A/AE-50A/EW-50A;*2
 TG-2000A can control max. 2000 indoor units.

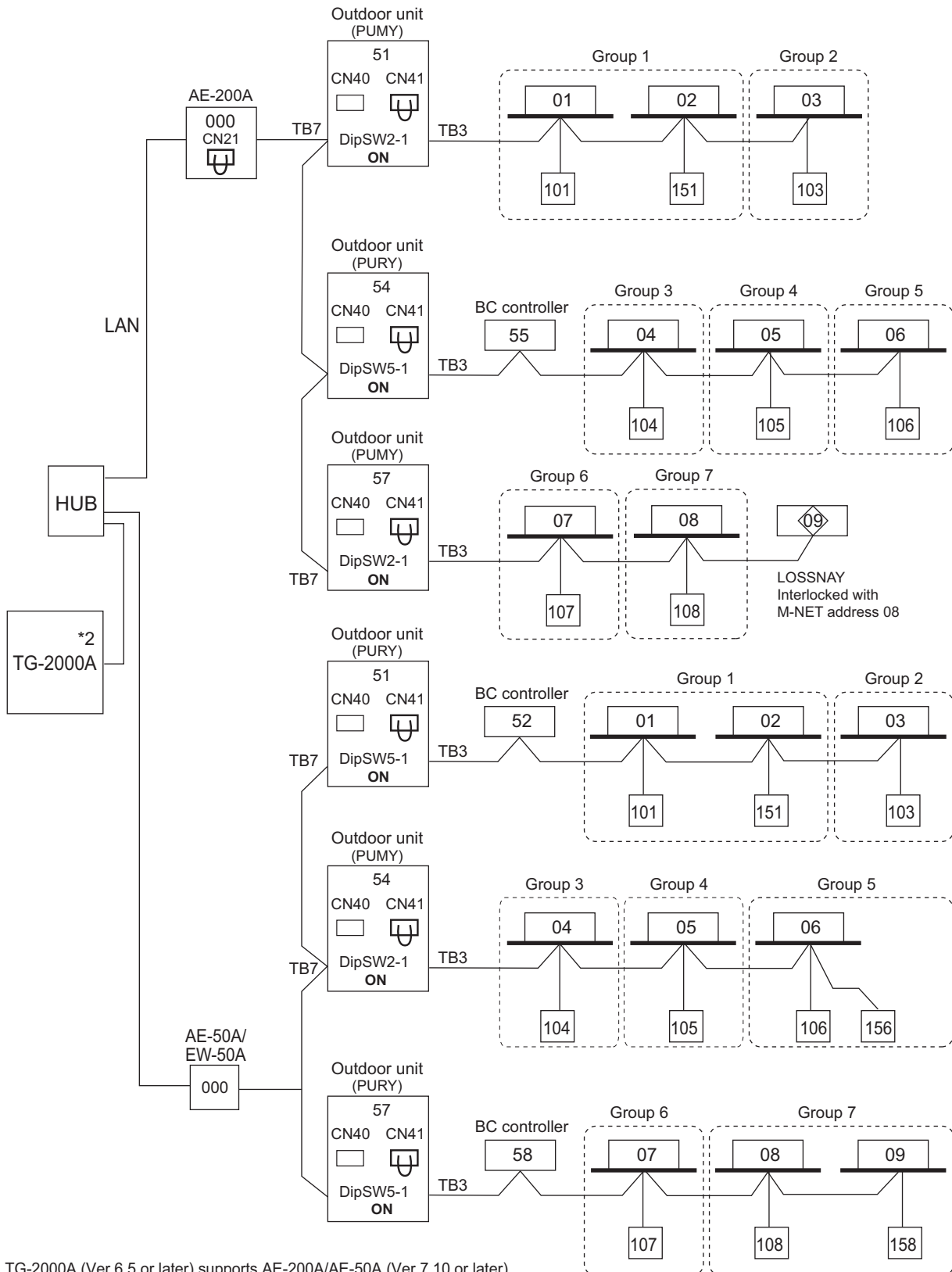

*1 TG-2000A (Ver.6.5 or later) supports AE-200A/AE-50A (Ver.7.10 or later).
 TG-2000A (Ver.6.60 or later) supports EW-50A.

*2 When AE-200A connected with AE-50A/EW-50A is connected, the number of AE-50A/EW-50A will be the maximum controllable number.
 TG-2000A can control up to 40 AE-200A/AE-50A/EW-50A or AE-200A without AE-50A/EW-50A connection.

2-4-3-7. AE-200A + AE-50A/EW-50A
 AE-200A can control max. 200 indoor units/via AE-50A/EW-50A.

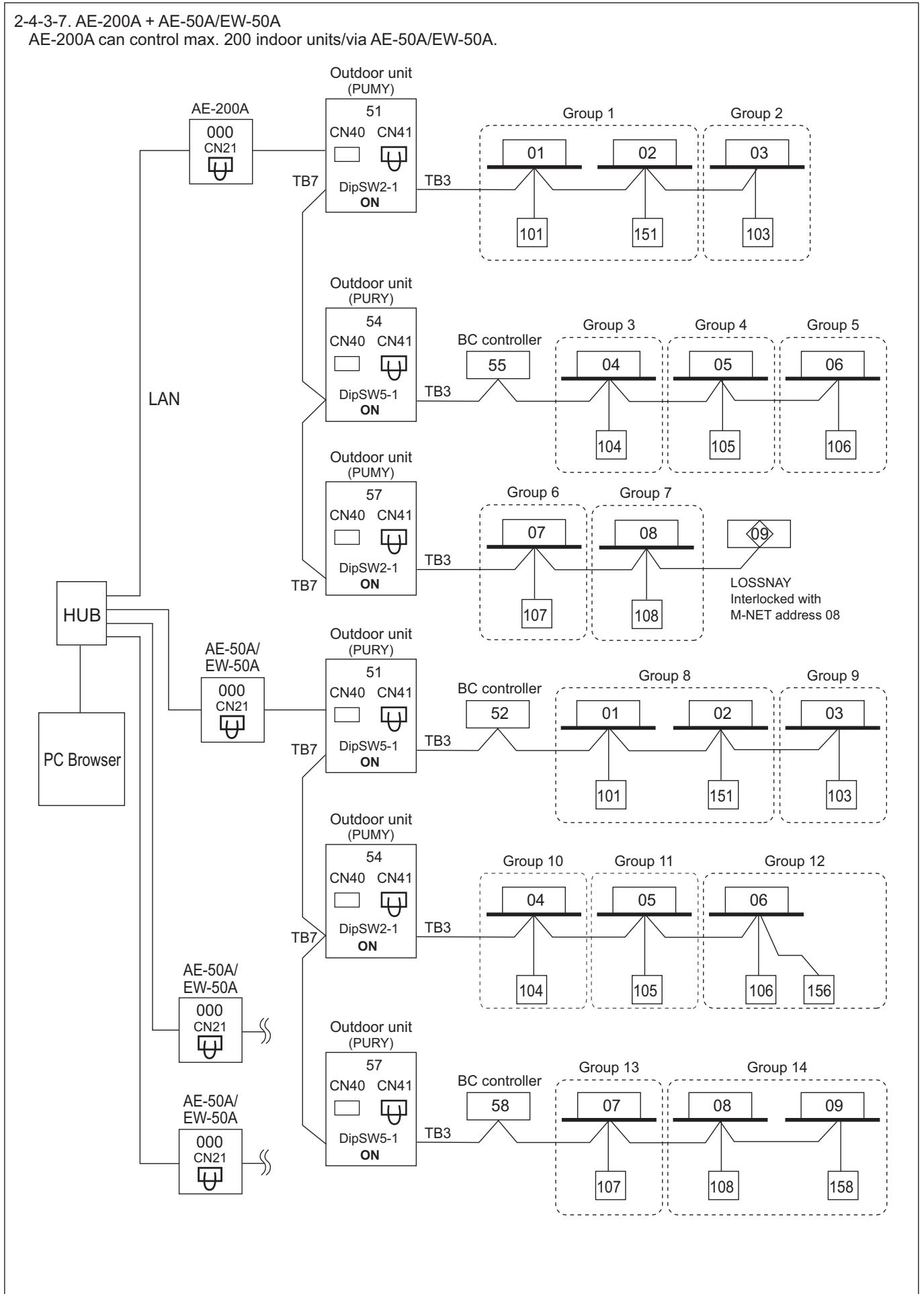

2-4-3-8. LM-AP

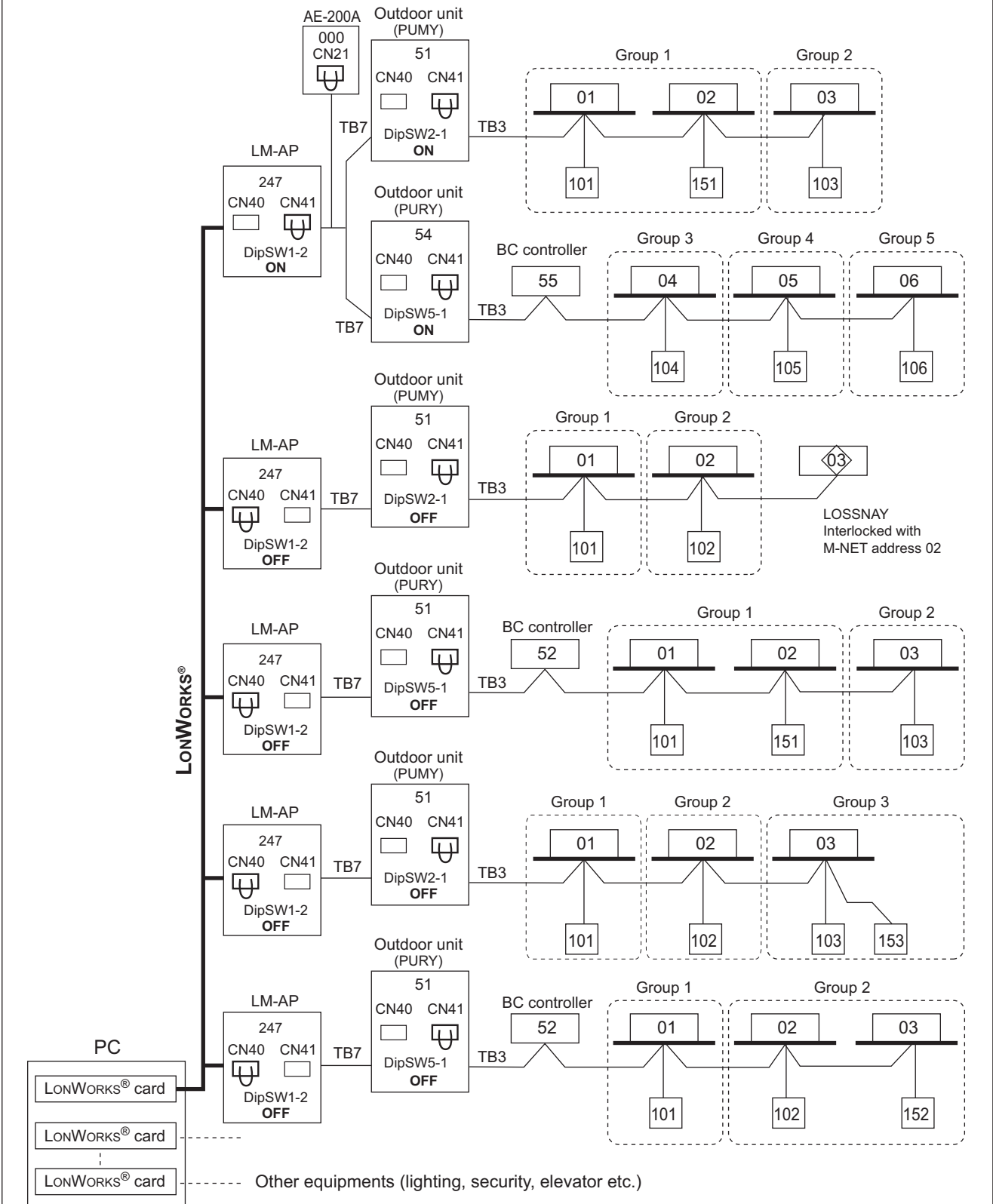

NOTE

- LM-AP can control 50 indoor units.
- It is necessary to turn on the DipSW1-2 on the LM-AP control board and the DipSW2-1 on the outdoor unit control board with central controllers (Power supply unit).
- It is necessary to change the connector to CN40 on the LM-AP control board without central controllers (Power supply unit).

2-4-3-9. BM ADAPTER

BM ADAPTER can transmit max. 50 indoor units;
 Change Jumper from CN41 to CN40 to activate power supply to BM ADAPTER itself for those BM ADAPTER connected without the power supply unit.

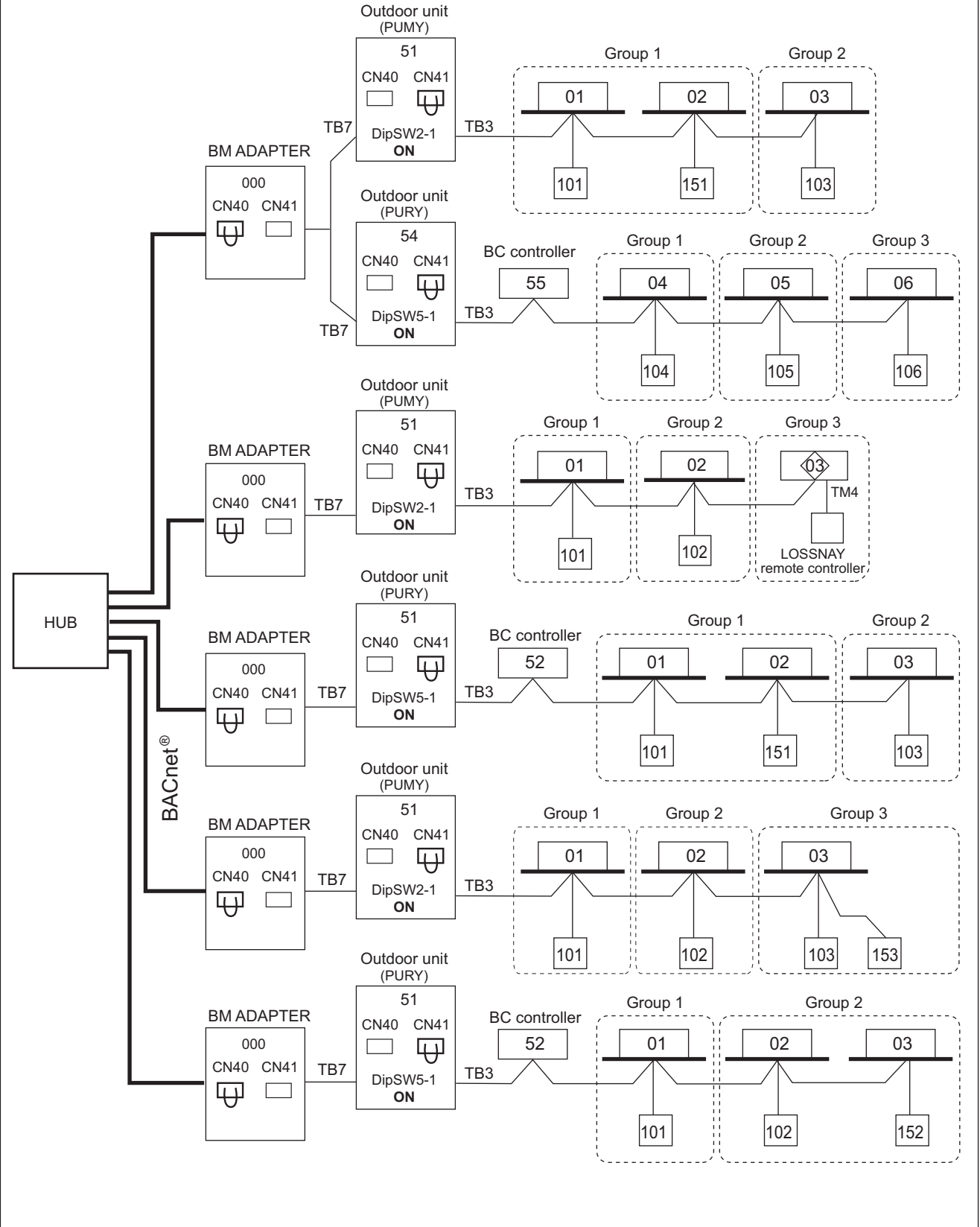

2-4-3-10. BM ADAPTER + PAC-YG50ECA (Expansion controller)

BM ADAPTER*1 can transmit max. 150 indoor units via expansion controllers (PAC-YG50ECA).
 When the dual-set-point function is used, no expansion controllers can be connected, and only up to 50 units can be controlled from each BAC-HD150.

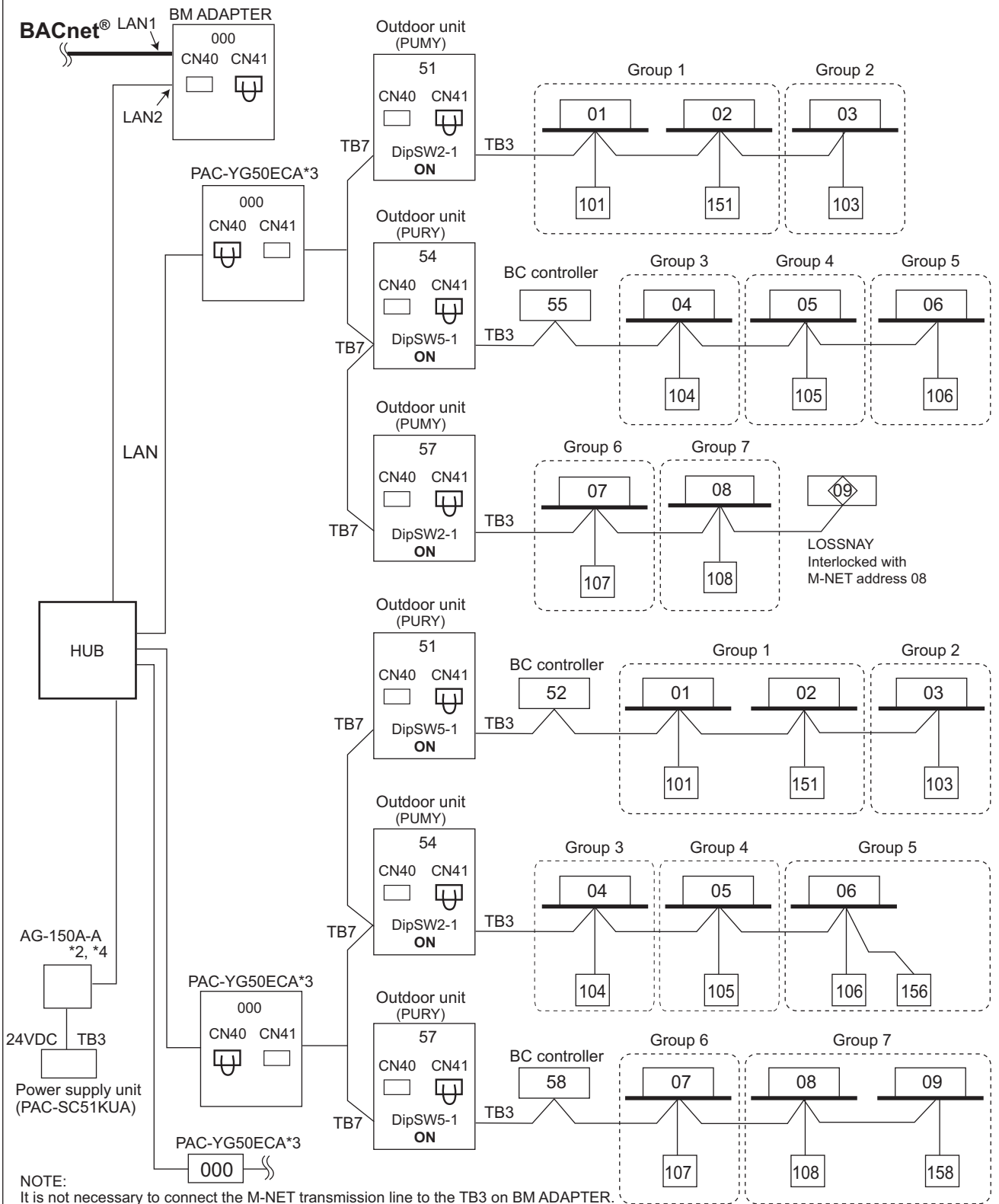

NOTE:
 It is not necessary to connect the M-NET transmission line to the TB3 on BM ADAPTER.
 Leave the power jumper of BM ADAPTER connected to CN41.

- *1 BM ADAPTER (Ver. 2.00 or later) supports the expansion controller.
- *2 AG-150A-A (Ver. 2.30 or later) supports the BM ADAPTER.
- *3 PAC-YG50ECA (Ver. 1.30 or later) supports the BM ADAPTER.
- *4 Consult your dealer for restrictions when connecting both AG-150A-A and BM ADAPTER to PAC-YG50ECA.

3-1. R410A Piping material

The maximum operation pressure of R410A air conditioner is 4.15 MPa [601 psi]. The refrigerant piping should ensure the safety under the maximum operation pressure. You shall follow the local industrial standard.

3-2. Piping Design

3-2-1. PUMY-P-NHMU Piping

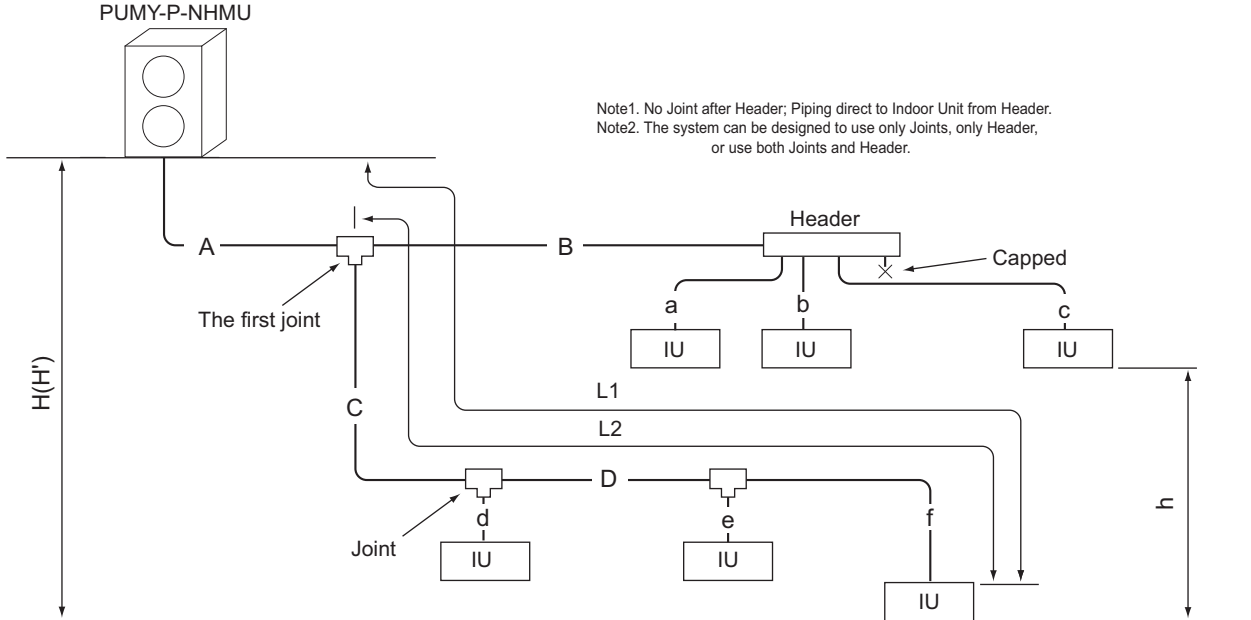

Fig. 3-2-1A Piping scheme

IU : Indoor unit , OU : Outdoor unit

Item	Piping in the figure	Max. length
Total piping length	A+B+C+D+a+b+c+d+e+f	120 [393']
Farthest IU from OU (L1)	A+C+D+f / A+B+c	80 [262']
Farthest IU from the first Joint (L2)	C+D+f / B+c	30 [98']
Height between OU and IU (OU above IU)	H	50 [164']
Height between OU and IU (OU under IU)	H'	20 [65']
Height between IU and IU	h	12 [39']

OU: Outdoor Unit, IU: Indoor Unit

Outdoor and the first-Joint/Header	Pipe(Liquid)	Pipe(Gas)
PUMY-P-NHMU=CMY-Y62-G-E	ø9.52 [3/8"]	ø15.88 [5/8"]
PUMY-P-NHMU=CMY-Y64,Y68-G-Eb	ø9.52 [3/8"]	ø15.88 [5/8"]

Total down-stream Indoor capacity	Pipe(Liquid)	Pipe(Gas)
~ P62	ø9.52 [3/8"]	ø15.88 [5/8"]

Indoor Unit size	Pipe(Liquid)	Pipe(Gas)
P06,P08,P12,P15,P18	ø6.35 [1/4"]	ø12.70 [1/2"]
P24,P27,P30,P36,P48,P54	ø9.52 [3/8"]	ø15.88 [5/8"]

Joint	4-branch Header	8-branch Header
CMY-Y62-G-E	CMY-Y64-G-E	CMY-Y68-G-E

* For details of installation of Joint, header, and distributor, refer to its Installation Manual.

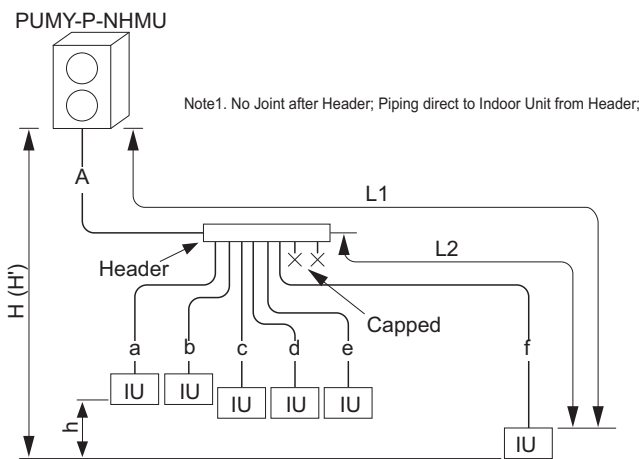
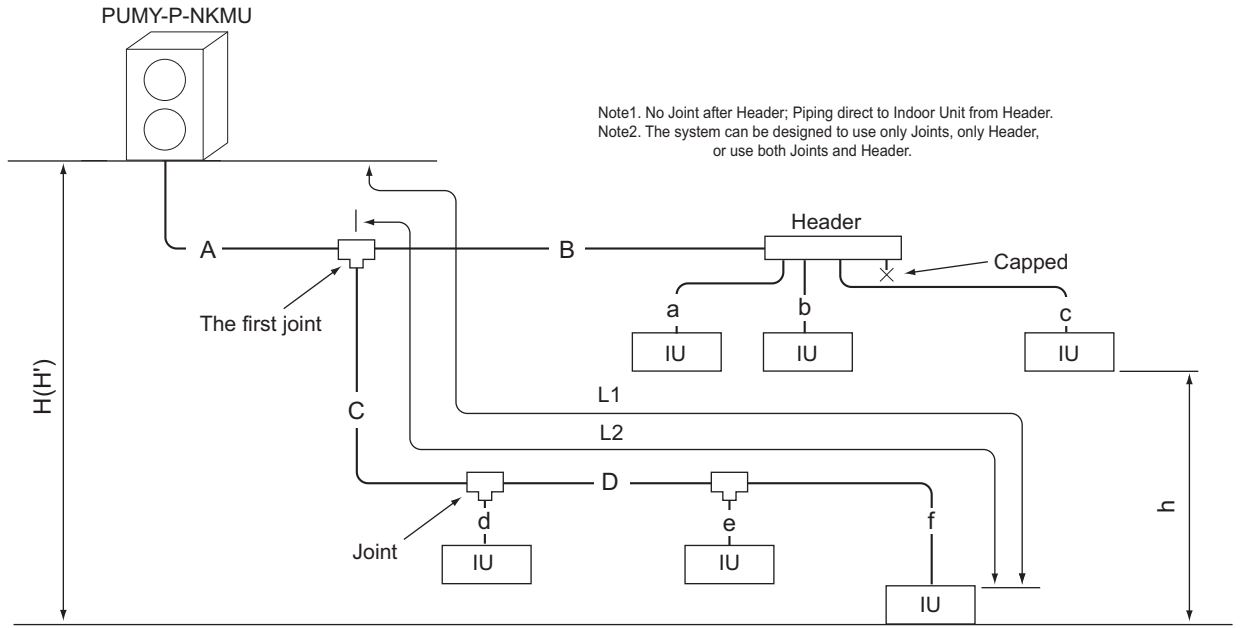

Fig. 3-2-1B Piping scheme

Item	Piping in the figure	Max. length
Total piping length	A+a+b+c+d+e+f	120 [393']
Farthest IU from OU (L1)	A+f	80 [262']
Farthest IU from Header (L2)	f	30 [98']
Height between OU and IU (OU above IU)	H	50 [164']
Height between OU and IU (OU under IU)	H'	20 [65']
Height between IU and IU	h	12 [39']

Note3. Indoor capacity is described as its model size.
 For example, PEFY-P08NMAU-E3, capacity P08;
 Note4. Total down-stream Indoor capacity is the summary of the model size of Indoors downstream.
 For example, PEFY-P08NMAU-E3+PEFY-P06NMAU-E3: Total Indoor capacity=P08+P06=P14;

3-2-2. PUMY-P-NKMU Piping



Note1. No Joint after Header; Piping direct to Indoor Unit from Header.
 Note2. The system can be designed to use only Joints, only Header, or use both Joints and Header.

Fig. 3-2-2A Piping scheme

IU : Indoor unit , OU : Outdoor unit

Item	Piping in the figure	Max. length
Total piping length	A+B+C+D+a+b+c+d+e+f	150 [492']
Farthest IU from OU (L1)	A+C+D+f / A+B+c	80 [262']
Farthest IU from the first Joint (L2)	C+D+f / B+c	30 [98']
Height between OU and IU (OU above IU)	H	50 [164']
Height between OU and IU (OU under IU)	H'	40 [131']
Height between IU and IU	h	15 [49']

OU: Outdoor Unit, IU: Indoor Unit

Outdoor and the first-Joint/Header	Pipe(Liquid)	Pipe(Gas)
PUMY-P-NKMU=CMY-Y62-G-E	ø9.52 [3/8"]	ø19.05 [3/4"]
PUMY-P-NKMU=CMY-Y64,Y68-G-Eb	ø9.52 [3/8"]	ø19.05 [3/4"]

Total down-stream Indoor capacity	Pipe(Liquid)	Pipe(Gas)
~ P78	ø9.52 [3/8"]	ø19.05 [3/4"]

Indoor Unit size	Pipe(Liquid)	Pipe(Gas)
P06,P08,P12,P15,P18	ø6.35 [1/4"]	ø12.70 [1/2"]
P24,P27,P30,P36,P48,P54	ø9.52 [3/8"]	ø15.88 [5/8"]
P72	ø9.52 [3/8"]	ø19.05 [3/4"]

Joint	4-branch Header	8-branch Header
CMY-Y62-G-E	CMY-Y64-G-E	CMY-Y68-G-E

* For details of installation of Joint, header, and distributor, refer to its Installation Manual.

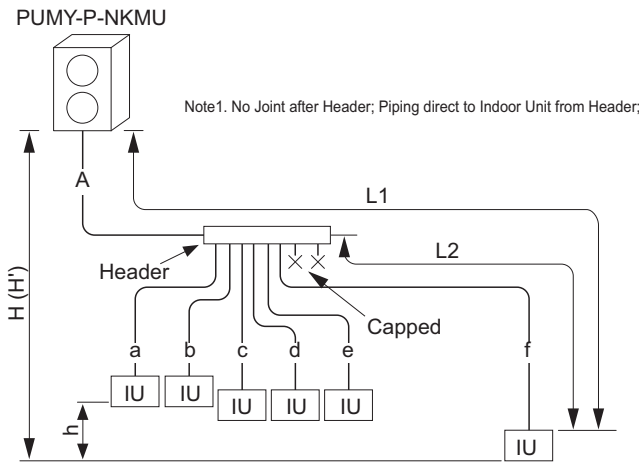

Note1. No Joint after Header; Piping direct to Indoor Unit from Header;

Fig. 3-2-2B Piping scheme

Item	Piping in the figure	Max. length
Total piping length	A+a+b+c+d+e+f	150 [492']
Farthest IU from OU (L1)	A+f	80 [262']
Farthest IU from Header (L2)	f	30 [98']
Height between OU and IU (OU above IU)	H	50 [164']
Height between OU and IU (OU under IU)	H'	40 [131']
Height between IU and IU	h	15 [49']

Note3. Indoor capacity is described as its model size.
 For example, PEFY-P08NMAU-E3, capacity P08;

Note4. Total down-stream Indoor capacity is the summary of the model size of Indoors downstream.
 For example, PEFY-P08NMAU-E3+PEFY-P06NMAU-E3: Total Indoor capacity=P08+P06=P14;

3-3. Refrigerant charging calculation

3-3-1. PUMY-P-NHMU

Original refrigerant charge for PUMY-P-NHMU is 8.5 kg [18.75 lbs], including 3 kg [106 oz] for 50 m [164 ft.] total extended piping length use. Thus, there is no need to charge additional refrigerant to the system if the total extended piping length is 50 m [164 ft.] or less.

If the total extended piping length is over 50 m [164 ft.], calculate the additional refrigerant using following procedure. Yet, if the calculated result is negative, no additional charge is needed.

Additional refrigerant charge	=	Total length of liquid pipe sized ø9.52 x 0.06 (kg/m) ø3/8" x 0.65 [oz/ft.]	+	Total length of liquid pipe sized ø6.35 x 0.024 (kg/m) ø1/4" x 0.26 [oz/ft.]	-	Original charge
(kg)		(m) x 0.06 (kg/m)		(m) x 0.024 (kg/m)		3.0 (kg)
[oz]		(ft.) x 0.65 [oz/ft.]		(ft.) x 0.26 [oz/ft.]		106 [oz]

Example:

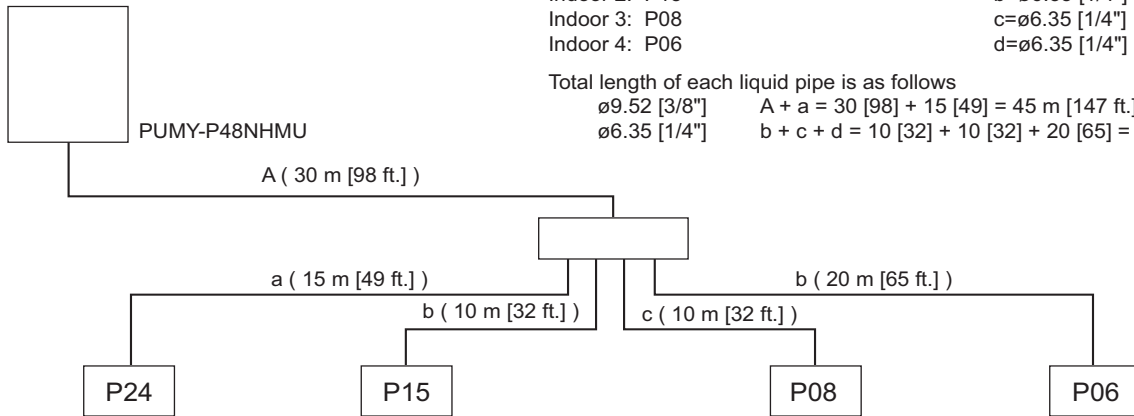

Indoor 1: P24 A=ø9.52 [3/8"] 30 m [98 ft.] a=ø9.52 [3/8"] 15 m [49 ft.]
 Indoor 2: P15 b=ø6.35 [1/4"] 10 m [32 ft.]
 Indoor 3: P08 c=ø6.35 [1/4"] 10 m [32 ft.]
 Indoor 4: P06 d=ø6.35 [1/4"] 20 m [65 ft.]

Total length of each liquid pipe is as follows
 ø9.52 [3/8"] A + a = 30 [98] + 15 [49] = 45 m [147 ft.]
 ø6.35 [1/4"] b + c + d = 10 [32] + 10 [32] + 20 [65] = 40 m [129 ft.]

Additional refrigerant charge	=	Total length of liquid pipe sized ø9.52 x 0.06 (kg/m)	+	Total length of liquid pipe sized ø6.35 x 0.024 (kg/m)	-	Original charge
(kg)		45 (m) x 0.06 (kg/m)		40 (m) x 0.024 (kg/m)		3.0(kg)

= 2.70 + 0.96 - 3.00

= 0.66

≈ 0.7 kg (round-up)

Additional refrigerant charge	=	Total length of liquid pipe sized ø3/8" x 0.65 [oz/ft.]	+	Total length of liquid pipe sized ø1/4" x 0.26 [oz/ft.]	-	Original charge
(oz)		147 (ft.) x 0.65 [oz/ft.]		129 (ft.) x 0.26 [oz/ft.]		106 [oz]

= 95.55 + 33.54 - 106

= 23.09 [oz]

≈ 1.5 [lbs] (round-up)

3-3-2. PUMY-P-NKMU

Additional refrigerant charge

Refrigerant for the extended piping is not included in the outdoor unit when the unit is shipped from the factory. Therefore, charge each refrigerant piping system with additional refrigerant at the installation site. In addition, in order to carry out service, enter the size and length of each liquid pipe and additional refrigerant charge amounts in the spaces provided on the "Refrigerant amount" plate on the outdoor unit.

Calculation of additional refrigerant charge

- Calculate the additional charge using the liquid pipe size and length of the extended piping.
- Calculate the additional refrigerant charge using the procedure shown to the right, and charge with the additional refrigerant.
- For amounts less than 0.1 kg, round up the calculated additional refrigerant charge.
(For example, if the calculated charge is 32.92 kg, round up the charge to 33.0 kg.)

Additional refrigerant charge	=	Pipe size Liquid pipe ø6.35	+	Pipe size Liquid pipe ø9.52	+	Total capacity of connected indoor units	Amount for the indoor units
		(m) × 0.027 (kg/m) 0.29 (oz/ft)		(m) × 0.07 (kg/m) 0.75 (oz/ft)		- 42	2.0 kg (71 oz)
						43 - 60	2.5 kg (88 oz)
(kg) [oz]						61 - 78	3.0 kg (106 oz)

Example:

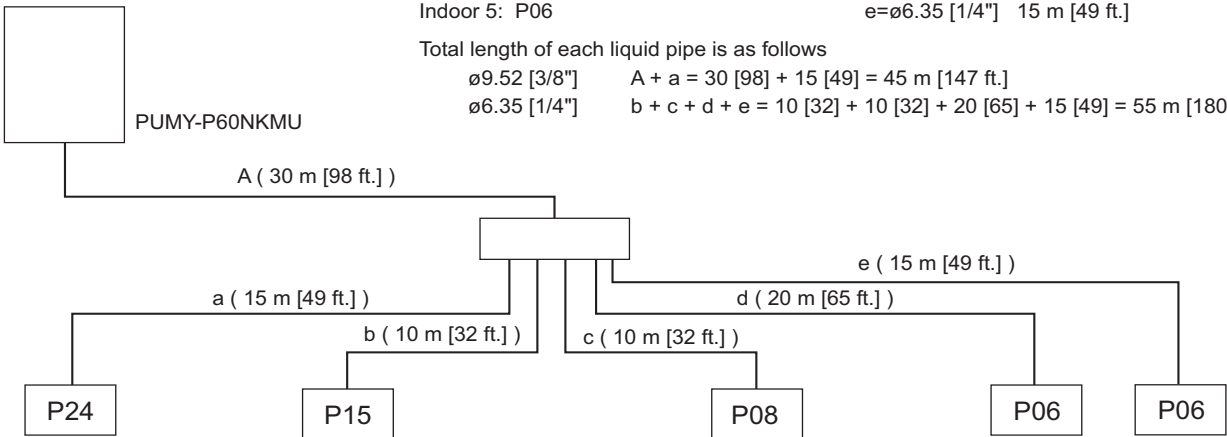

Indoor 1: P24 A=ø9.52 [3/8"] 30 m [98 ft.] a=ø9.52 [3/8"] 15 m [49 ft.]
 Indoor 2: P15 b=ø6.35 [1/4"] 10 m [32 ft.]
 Indoor 3: P08 c=ø6.35 [1/4"] 10 m [32 ft.]
 Indoor 4: P06 d=ø6.35 [1/4"] 20 m [65 ft.]
 Indoor 5: P06 e=ø6.35 [1/4"] 15 m [49 ft.]

Total length of each liquid pipe is as follows
 ø9.52 [3/8"] A + a = 30 [98] + 15 [49] = 45 m [147 ft.]
 ø6.35 [1/4"] b + c + d + e = 10 [32] + 10 [32] + 20 [65] + 15 [49] = 55 m [180 ft.]

Additional refrigerant charge	=	Total length of liquid pipe sized ø9.52 x 0.07 (kg/m)	+	Total length of liquid pipe sized ø6.35 x 0.027 (kg/m)	+	Total capacity of connected indoor units	Amount for the indoor units
		45 (m) x 0.07 (kg/m)		55 (m) x 0.027 (kg/m)		- 42	2.0 kg (71 oz)
						43 - 60	2.5 kg (88 oz)
(kg)						61 - 78	3.0 kg (106 oz)

$$= 3.15 + 1.49 + 2.5$$

$$= 7.14$$

$$\approx 7.2 \text{ kg (round-up)}$$

Additional refrigerant charge	=	Total length of liquid pipe sized ø3/8" x 0.75 [oz/ft.]	+	Total length of liquid pipe sized ø1/4" x 0.29 [oz/ft.]	+	Total capacity of connected indoor units	Amount for the indoor units
		147 (ft.) x 0.75 [oz/ft.]		180 (ft.) x 0.29 [oz/ft.]		- 42	2.0 kg (71 oz)
						43 - 60	2.5 kg (88 oz)
(oz)						61 - 78	3.0 kg (106 oz)

$$= 110.25 + 52.2 + 88$$

$$= 250.45 \text{ [oz]}$$

$$\approx 251 \text{ [oz] (round-up)}$$

4-1. Requirement on installation site

4-1-1. General caution

- A. Avoid locations exposed to direct sunlight or other sources of heat.
- B. Select a location from which noise emitted by the unit will not inconvenience the neighbors.
- C. Select a location permitting easy wiring and pipe access to the power source and indoor unit.
- D. Avoid locations where combustible gases may leak, be produced, flow, or accumulate.
- E. Note that water may drain from the unit during operation.
- F. Select a level location that can bear the weight and vibration of the unit.
- G. Avoid locations where the unit can be covered by snow. In areas where heavy snow fall is anticipated, special precautions such as raising the installation location or installing a hood on the air intake must be taken to prevent the snow from blocking the air intake or blowing directly against it. This can reduce the airflow and a malfunction may result.
- H. Avoid locations exposed to oil, steam, or sulfuric gas.
- I. Use the transportation handles of the outdoor unit to transport the unit. If the unit is carried from the bottom, hands or fingers may be pinched.

4-1-2. Installation at windy location.

When installing the outdoor unit on a rooftop or other location unprotected from the wind, situate the air outlet of the unit so that it is not directly exposed to strong winds. Strong wind entering the air outlet may impede the normal airflow and a malfunction may result.

The following shows two examples of precautions against strong winds.

- ① Install an optional air guide if the unit is installed in a location where strong winds from a typhoon, etc. may directly enter the air outlet. (Fig. 4-1-2a)
 - Ⓐ Air guide
- ② Position the unit so that the air outlet blows perpendicularly to the seasonal wind direction, if possible. (Fig. 4-1-2b)
 - Ⓑ Wind direction

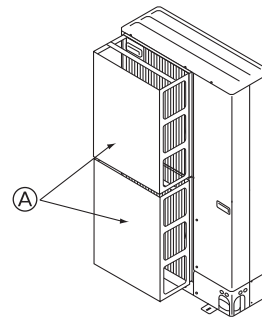

Fig. 4-1-2a

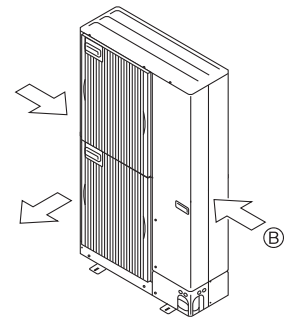

Fig. 4-1-2b

4-1-3. Foundation

A. Be sure to install the unit in a sturdy, level surface to prevent rattling noises during operation. (see Fig. 4-1-3)

B. Foundation specifications are as follows. mm [in.]

Thickness of concrete	Weight-bearing capacity	Foundation bolt	Bolt length
120 [4-3/4"]	320 kg [706lbs]	M10 [3/8"]	70 [2-25/32"]

C. Make sure that the length of the foundation bolt is within 30 mm [1-3/16"] of the bottom surface of the base.

D. Secure the base of the unit firmly with four-M10 [3/8"] foundation bolts in sturdy locations.

⚠ Warning:

- A. The foundation base should be strong enough to support the outdoor unit, otherwise, it may fall down and cause damage or injuries.
- B. The unit must be installed according to the instructions in order to minimize the risk of damage from earthquakes, typhoons, or strong winds.

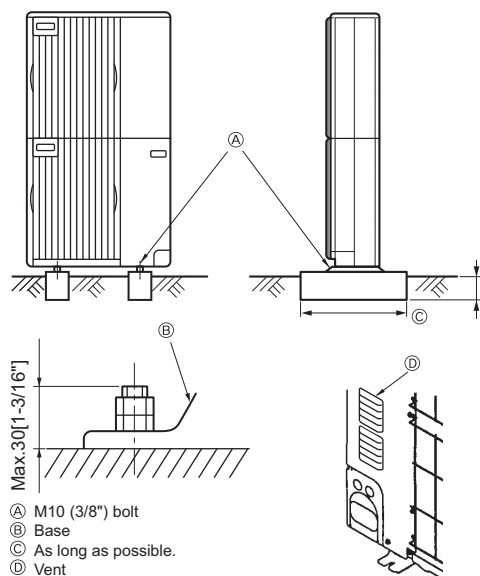

- Ⓐ M10 (3/8") bolt
- Ⓑ Base
- Ⓒ As long as possible.
- Ⓓ Vent

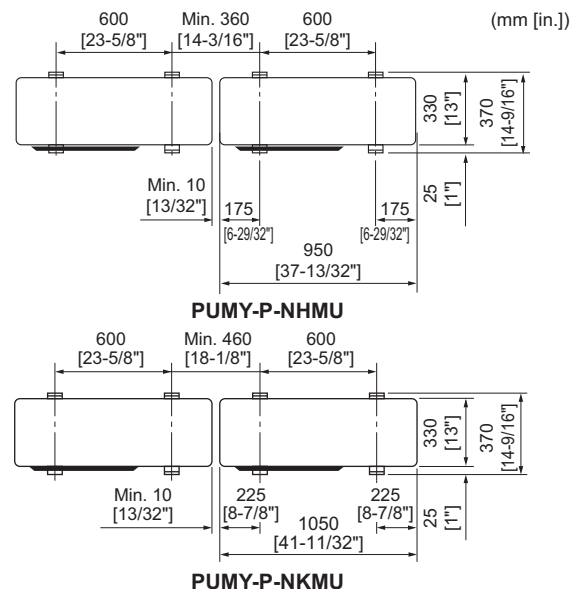
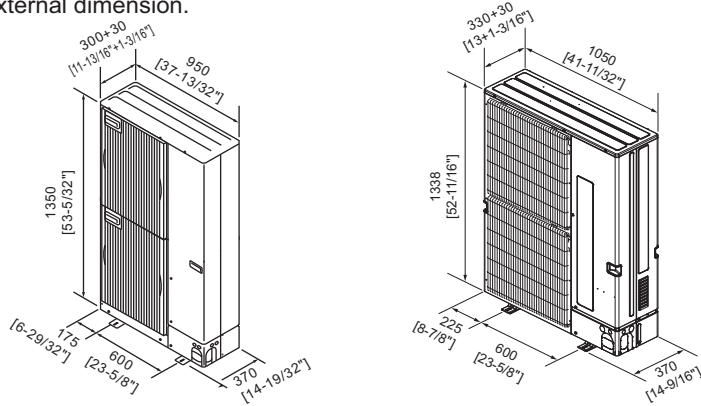

Fig. 4-1-3

4-2. Spacing

External dimension.



Connectable Indoor capacity		Connectable Indoor unit
PUMY-P36NHMU	P18 - P46	P06-P36, 1-6 units
PUMY-P48NHMU	P24 - P62	P06-P54, 1-8 units
PUMY-P60NKMU	P30 - P78	P06-P72, 1-12 units

Fig. 4-2-1 PUMY-P-NHMU dimension PUMY-P-NKMU dimension

4-2-1. Spacing individual PUMY-P-NHMU/NKMU
Follow Fig. 4-2-2~7 to space individual PUMY-P-NHMU/NKMU at the installation site.

4-2-2. Spacing grouped PUMY-P-NHMU/NKMU
Follow Fig. 4-2-8~13 to space grouped PUMY-P-NHMU/NKMU at the installation site. Leave 10 mm [13/32"] space or more between PUMY-P-NHMU/NKMU units.

mm[in.]

mm[in.]

Fig. 4-2-2
Obstacles at rear only

Fig. 4-2-3
Obstacles at rear and above only

Fig. 4-2-8
Obstacles at rear or front only

Fig. 4-2-9
Obstacles at rear and above only

Fig. 4-2-4
Obstacles at rear and sides only

Fig. 4-2-5
Obstacles at front only

Fig. 4-2-10
Obstacles at front and rear only

Fig. 4-2-11
Parallel individuals arrangement

Fig. 4-2-6
Obstacles at front and rear only

Fig. 4-2-7
Obstacles at rear, sides and above only

Fig. 4-2-12
Parallel groups arrangement

Fig. 4-2-13
Stacked groups arrangement

* When using an optional air outlet guide, the clearance is 1000 mm [39-3/8"] or more.

* Do not install the optional air outlet guides for upward airflow.

* In case of side-by-side installation, <=3 units;

* Using an optional air outlet guide, the clearance >= 500 mm [19-11/16"].

* Using an optional air outlet guide, the clearance >= 1000 mm [39-3/8"].

* Using an optional air outlet guide, the clearance >= 1000 mm [39-3/8"].

* Using an optional air outlet guide, the clearance >= 500 mm [19-11/16"].

* NO upward airflow outlet guide.

* Using an optional air outlet guide for upward airflow, the clearance >= 1500 mm [59-1/16"].

* Stacked layer <= 2 units;

* Side-by-side stacked groups <= 2 groups;

4-3. Piping direction

4-3-1. PUMY-P-NHMU

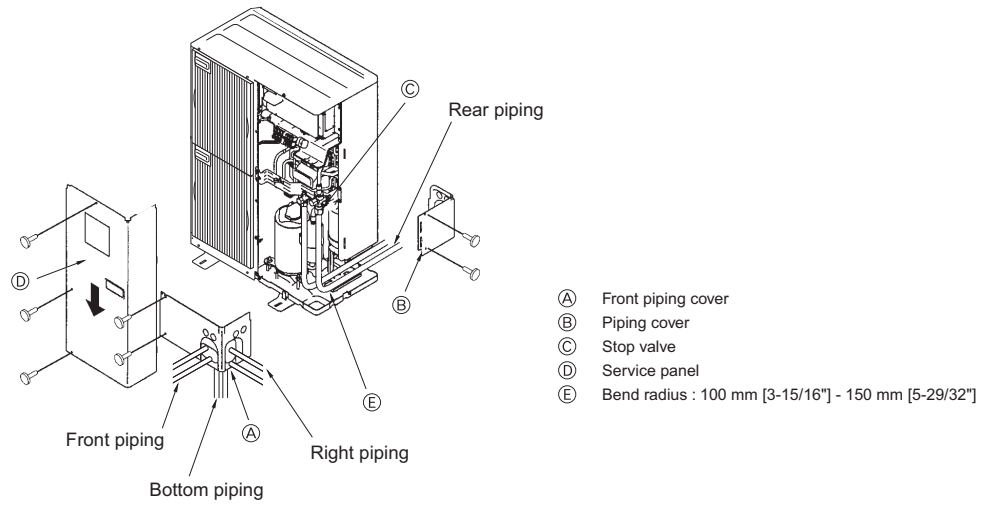

4-3-2. PUMY-P-NKMU

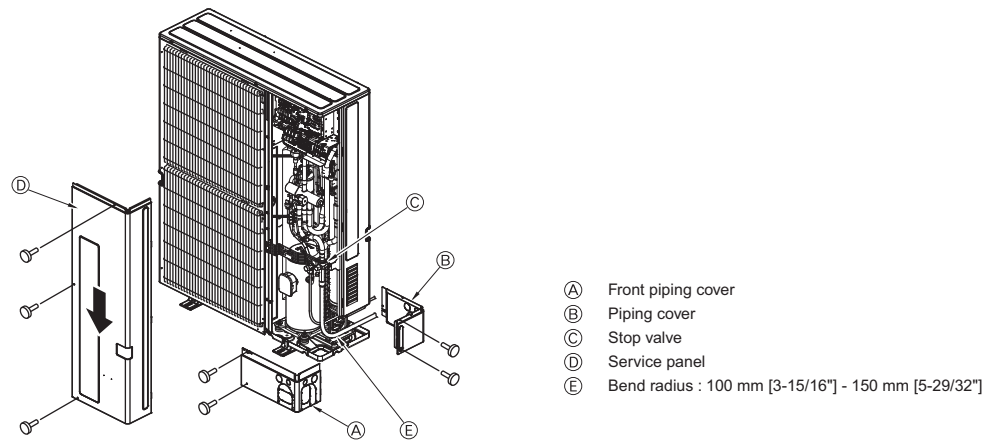

CITY MULTI

INSTALLATION INFORMATION

1. Installation information	4 - 470
1-1.General precautions	4 - 470
1-2.Precautions for Indoor unit and BC controller.....	4 - 472
1-3.Precautions for Outdoor unit/Heat source unit	4 - 473
1-4.Precautions for Control-related items	4 - 474

1-1. General precautions

1-1-1. Usage

- The air-conditioning system described in this Data Book is designed for human comfort.
- This product is not designed for preservation of food, animals, plants, precision equipment, or art objects. To prevent quality loss, do not use the product for purposes other than what it is designed for.
- To reduce the risk of water leakage and electric shock, do not use the product for air-conditioning vehicles or vessels.

1-1-2. Installation environment

- Do not install any unit other than the dedicated unit in a place where the voltage changes a lot, large amounts of mineral oil (e.g., cutting oil) are present, cooking oil may splash, or a large quantity of steam can be generated such as a kitchen.
- Do not install the unit in acidic or alkaline environment.
- Installation should not be performed in the locations exposed to chlorine or other corrosive gases. Avoid near a sewer.
- To reduce the risk of fire, do not install the unit in a place where flammable gas may be leaked or inflammable material is present.
- This air conditioning unit has a built-in microcomputer. Take the noise effects into consideration when deciding the installation position. Especially in a place where antenna or electronic device are installed, it is recommended that the air conditioning unit be installed away from them.
- Install the unit on a solid foundation according to the local safety measures against typhoons, wind gusts, and earthquakes to prevent the unit from being damaged, toppling over, and falling.

1-1-3. Backup system

- In a place where air conditioner's malfunctions may exert crucial influence, it is recommended to have two or more systems of single outdoor/heat source units with multiple indoor units.

1-1-4. Unit characteristics

- Heat pump efficiency of outdoor unit depends on outdoor temperature. In the heating mode, performance drops as the outside air temperature drops. In cold climates, performance can be poor. Warm air would continue to be trapped near the ceiling and the floor level would continue to stay cold. In this case, heat pumps require a supplemental heating system or air circulator. Before purchasing them, consult your local distributor for selecting the unit and system.
- When the outdoor temperature is low and the humidity is high, the heat exchanger on the outdoor unit side tends to collect frost, which reduces its heating performance. To remove the frost, Auto-defrost function will be activated and the heating mode will temporarily stop for 3-10 minutes. Heating mode will automatically resume upon completion of defrost process.
- Air conditioner with a heat pump requires time to warm up the whole room after the heating operation begins, because the system circulates warm air in order to warm up the whole room.
- The sound levels were obtained in an anechoic room. The sound levels during actual operation are usually higher than the simulated values due to ambient noise and echoes. Refer to the section on "SOUND LEVELS" for the measurement location.
- Depending on the operation conditions, the unit generates noise caused by valve actuation, refrigerant flow, and pressure changes even when operating normally. Please consider to avoid location where quietness is required. For BC/HBC controller, it is recommended to unit to be installed in places such as ceilings of corridor, restrooms and plant rooms.
- The total capacity of the connected indoor units can be greater than the capacity of the outdoor/heat source unit. However, when the connected indoor units operate simultaneously, each unit's capacity may become smaller than the rated capacity.
- When the unit is started up for the first time within 12 hours after power on or after power failure, it performs initial startup operation (capacity control operation) to prevent damage to the compressor. The initial startup operation requires 90 minutes maximum to complete, depending on the operation load.

1-1-5. Relevant equipment

- Use an earth leakage breaker (ELB) with medium sensitivity, and an activation speed of 0.1 second or less.
- Consult your local distributor or a qualified technician when installing an earth leakage breaker.
- If the unit is inverter type, select an earth leakage breaker for handling high harmonic waves and surges.
- Leakage current is generated not only through the air conditioning unit but also through the power wires. Therefore, the leakage current of the main power supply is greater than the total leakage current of each unit. Take into consideration the capacity of the earth leakage breaker or leakage alarm when installing one at the main power supply. To measure the leakage current simply on site, use a measurement tool equipped with a filter, and clamp all the four power wires together. The leakage current measured on the ground wire may not accurate because the leakage current from other systems may be included to the measurement value.
- Do not install a phase advancing capacitor on the unit connected to the same power system with an inverter type unit and its equipment.
- If a large current flows due to the product malfunctions or faulty wiring, both the earth leakage breaker on the product side and the upstream overcurrent breaker may trip almost at the same time. Separate the power system or coordinate all the breakers depending on the system's priority level.

1-1-6. Unit installation

- ♦Your local distributor or a qualified technician must read the Installation Manual that is provided with each unit carefully before performing installation work.
- ♦Consult your local distributor or a qualified technician when installing the unit. Improper installation by an unqualified person may result in water leakage, electric shock, or fire.
- ♦Ensure there is enough space around each unit.

1-1-7. Optional accessories

- ♦Only use accessories recommended by Mitsubishi Electric. Consult your local distributor or a qualified technician when installing them. Improper installation by an unqualified person may result in water leakage, electric leakage, system breakdown, or fire.
- ♦Some optional accessories may not be compatible with the air conditioning unit to be used or may not be suitable for the installation conditions. Check the compatibility when considering any accessories.
- ♦Note that some optional accessories may affect the air conditioner's external form, appearance, weight, operating sound, and other characteristics.

1-1-8. Operation/Maintenance

- ♦Read the Instruction Book that is provided with each unit carefully prior to use.
- ♦Maintenance or cleaning of each unit may be risky and require expertise. Read the Instruction Book to ensure safety. Consult your local distributor or a qualified technician when special expertise is required such as when the indoor unit needs to be cleaned.

1-2. Precautions for Indoor unit and BC controller

1-2-1. Operating environment

- The refrigerant (R410A) used for air conditioner is non-toxic and nonflammable. However, if the refrigerant leaks, the oxygen level may drop to harmful levels. If the air conditioner is installed in a small room, measures must be taken to prevent the refrigerant concentration from exceeding the safety limit even if the refrigerant should leak.
- If the units operate in the cooling mode at the humidity above 80%, condensation may collect and drip from the indoor units.

1-2-2. Unit characteristics

- The return air temperature display on the remote controller may differ from the ones on the other thermometers.
- The clock on the remote controller may be displayed with a time lag of approximately one minute every month.
- The temperature using a built-in temperature sensor on the remote controller may differ from the actual room temperature due to the effect of the wall temperature.
- Use a built-in thermostat on the remote controller or a separately-sold thermostat when indoor units installed on or in the ceiling operate the automatic cooling/heating switchover.
- The room temperature may rise drastically due to Thermo OFF in the places where the air conditioning load is large such as computer rooms.
- Be sure to use a regular filter. If an irregular filter is installed, the unit may not operate properly, and the operation noise may increase.
- The room temperature may rise over the preset temperature in the environment where the heating air conditioning load is small.

1-2-3. Unit installation

- For simultaneous cooling/heating operation type air conditioners (R2, H2i R2, WR2 series), the G-type BC controller cannot be connected to the P144 outdoor/heat source unit model or above, and the G- and GA-type BC controllers cannot be connected to the P264 model or above. The GB- and HB-type BC controllers (sub) cannot be connected to the outdoor/heat source unit directly, and be sure to use them with GA- and HA-type BC controllers (main).
- The insulation for low pressure pipe between the BC controller and outdoor/heat source unit shall be at least 20 mm thick. If the unit is installed on the top floor or in a high-temperature, high-humidity environment, thicker insulation may be necessary.
- Do not have any branching points on the downstream of the refrigerant pipe header.
- When a field-supplied external thermistor is installed or when a device for the demand control is used, abnormal stop of the unit or damage of the electromagnetic contactor may occur. Consult your local distributor for details.
- When indoor units operate a fresh air intake, install a filter in the duct (field-supplied) to remove the dust from the air.
- The 4-way or 2-way Airflow Ceiling Cassette Type units that have an outside air inlet can be connected to the duct, but need a booster fan to be installed at site. Refer to the chapter "Indoor Unit" for the available range for fresh air intake volume.
- Operating fresh air intake on the indoor unit may increase the sound pressure level.

1-3. Precautions for Outdoor unit/Heat source unit

1-3-1. Installation environment

- ♦Outdoor/heat source unit with salt-resistant specification is recommended to use in a place where it is subject to salt air.
 - ♦Even when the unit with salt-resistant specification is used, it is not completely protected against corrosion. Be sure to follow the directions or precautions described in Instructions Book and Installation Manual for installation and maintenance. The salt-resistant specification is referred to the guidelines published by JRAIA (JRA9002).
 - ♦Install the unit in a place where the flow of discharge air is not obstructed. If not, the short-cycling of discharge air may occur.
 - ♦Provide proper drainage around the unit base, because the condensation may collect and drip from the outdoor/heat source units. Provide water-proof protection to the floor when installing the units on the rooftop.
 - ♦In a region where snowfall is expected, install the unit so that the outlet faces away from the direction of the wind, and install a snow guard to protect the unit from snow. Install the unit on a base approximately 50 cm higher than the expected snowfall. Close the openings for pipes and wiring, because the ingress of water and small animals may cause equipment damage. If SUS snow guard is used, refer to the Installation Manual that comes with the snow guard and take caution for the installation to avoid the risk of corrosion.
 - ♦When the unit is expected to operate continuously for a long period of time at outside air temperatures of below 0°C, take appropriate measures, such as the use of a unit base heater, to prevent icing on the unit base. (Not applicable to the PUMY-P-NHMu series)
 - ♦Install the snow guard so that the outlet/inlet faces away from the direction of the wind.
 - ♦When the snow accumulates approximately 50 cm or more on the snow guard, remove the snow from the guard. Install a roof that is strong enough to withstand snow loads in a place where snow accumulates.
 - ♦Provide proper protection around the outdoor/heat source units in places such as schools to avoid the risk of injury.
 - ♦A cooling tower and heat source water circuit should be a closed circuit that water is not exposed to the atmosphere. When a tank is installed to ensure that the circuit has enough water, minimize the contact with outside air so that the oxygen from being dissolved in the water should be 1 mg/L or less.
 - ♦Install a strainer (50 mesh or more recommended) on the water pipe inlet on the heat source unit.
 - ♦Interlock the heat source unit and water circuit pump.
 - ♦Note the followings to prevent the freeze bursting of pipe when the heat source unit is installed in a place where the ambient temperature can be 0°C or below.
 - ♦Keep the water circulating to prevent it from freezing when the ambient temperature is 0°C or below.
 - ♦Before a long period of non use, be sure to purge the water out of the unit.
 - ♦Salt-resistant unit is resistant to salt corrosion, but not salt-proof.
- Please note the following when installing and maintaining outdoor units in marine atmosphere.
1. Install the salt-resistant unit out of direct exposure to sea breeze, and minimize the exposure to salt water mist.
 2. Avoid installing a sun shade over the outdoor unit, so that rain will wash away salt deposits off the unit.
 3. Install the unit horizontally to ensure proper water drainage from the base of the unit. Accumulation of water in the base of the outdoor unit will significantly accelerate corrosion.
 4. Periodically wash salt deposits off the unit, especially when the unit is installed in a coastal area.
 5. Repair all noticeable scratches after installation and during maintenance.
 6. Periodically check the unit, and apply anti-rust agent and replace corroded parts as necessary.

1-3-2. Circulating water

- ♦Follow the guidelines published by JRAIA (JRA-GL02-1994) to check the water quality of the water in the heat source unit regularly.
- ♦A cooling tower and heat source water circuit should be a closed circuit that water is not exposed to the atmosphere. When a tank is installed to ensure that the circuit has enough water, minimize the contact with outside air so that the oxygen from being dissolved in the water should be 1 mg/L or less.

1-3-3. Unit characteristics

- ♦When the Thermo ON and OFF is frequently repeated on the indoor unit, the operation status of outdoor/heat source units may become unstable.

1-3-4. Relevant equipment

- ♦Provide grounding in accordance with the local regulations.

1-4. Precautions for Control-related items

1-4-1. Product specification

- To introduce the MELANS system, a consultation with us is required in advance. Especially to introduce the electricity charge apportioning function or energy-save function, further detailed consultation is required. Consult your local distributor for details.
- Billing calculation for AE-200A/AE-50A/EW-50A/AG-150A-A/EB-50GU-A/TG-2000A, or the billing calculation unit is unique and based on our original method. (Backup operation is included.) It is not based on the metering method, and do not use it for official business purposes. It is not the method that the amount of electric power consumption (input) by air conditioner is calculated. Note that the electric power consumption by air conditioner is apportioned by using the ratio corresponding to the operation status (output) for each air conditioner (indoor unit) in this method.
- In the apportioned billing function for AE-200A/AE-50A/EW-50A/AG-150A-A and EB-50GU-A, use separate watt-hour meters for A-control units, K-control units^{*1}, and packaged air conditioner for City Multi air conditioners. It is recommended to use an individual watt-hour meter for the large-capacity indoor unit (with two or more addresses).
- When using the peak cut function on the AE-200A/AE-50A/EW-50A/AG-150A-A or EB-50GU-A, note that the control is performed once every minute and it takes time to obtain the effect of the control. Take appropriate measures such as lowering the criterion value. Power consumption may exceed the limits if AE-200A/AE-50A/EW-50A/AG-150A-A or EB-50GU-A malfunctions or stops. Provide a back-up remedy as necessary.
- The controllers cannot operate while the indoor unit is OFF. (No error)
Turn ON the power to the indoor unit when operating the controllers.
- When using the interlocked control function on the AE-200A/AE-50A/EW-50A/AG-150A-A/EB-50GU-A/PAC-YG66DCA or PAC-YG63MCA, do not use it for the control for the fire prevention or security. (This function should never be used in the way that would put people's lives at risk.) Provide any methods or circuit that allow ON/OFF operation using an external switch in case of failure.

1-4-2. Installation environment

- The surge protection for the transmission line may be required in areas where lightning strikes frequently occur.
- A receiver for a wireless remote controller may not work properly due to the effect of general lighting. Leave a space of at least 1 m between the general lighting and receiver.
- When the Auto-elevating panel is used and the operation is made by using a wired remote controller, install the wired remote controller to the place where all air conditioners controlled (at least the bottom part of them) can be seen from the wired remote controller. If not, the descending panel may cause damage or injury, and be sure to use a wireless remote controller designed for use with elevating panel (sold separately).
- Install the wired remote controller (switch box) to the place where the following conditions are met.
 - Where installation surface is flat
 - Where the remote controller can detect an accurate room temperature
The temperature sensors that detect a room temperature are installed both on the remote controller and indoor unit. When a room temperature is detected using the sensor on the remote controller, the main remote controller is used to detect a room temperature. In this case, follow the instructions below.
 - Install the controller in a place where it is not subject to the heat source.
(If the remote controller faces direct sunlight or supply air flow direction, the remote controller cannot detect an accurate room temperature.)
 - Install the controller in a place where an average room temperature can be detected.
 - Install the controller in a place where no other wires are present around the temperature sensor.
(If other wires are present, the remote controller cannot detect an accurate room temperature.)
- To prevent unauthorized access, always use a security device such as a VPN router when connecting AE-200A/AE-50A/EW-50A/AG-150A/EB-50GU-A or TG-2000A to the Internet.

*1.EB-50GU-A, AE-200A, AE-50A, and EW-50A cannot be used to control K-control units.

CITY MULTI

CAUTION FOR REFRIGERANT LEAKAGE

1. Caution for refrigerant leakage	4 - 476
1-1.Refrigerant property	4 - 476
1-2.Confirm the Critical concentration and take countermeasure.....	4 - 476

The installer and/or air conditioning system specialist shall secure safety against refrigerant leakage according to local regulations or standards. The following standard may be applicable if no local regulation or standard is available.

1-1. Refrigerant property

R410A refrigerant is harmless and incombustible. The R410A is heavier than the indoor air in density. Leakage of the refrigerant in a room has possibility to lead to a hypoxia situation. Therefore, the critical concentration specified below shall not be exceeded even if the leakage happens.

• Critical concentration

Critical concentration hereby is the refrigerant concentration in which no human body would be hurt if immediate measures can be taken when refrigerant leakage happens.

Critical concentration of R410A: 0.44kg/m³
(The weight of refrigeration gas per 1 m³ air conditioning space.);

* The Critical concentration is subject to ISO5149, EN378-1.

For the CITY MULTI system, the concentration of refrigerant leaked should not have a chance to exceed the critical concentration in any situation.

1-2. Confirm the Critical concentration and take countermeasure

The maximum refrigerant leakage concentration (Rmax) is defined as the result of the possible maximum refrigerant weight (Wmax) leaked into a room divided by its room capacity (V). It is referable to Fig.1-1. The refrigerant of Outdoor/Heat source unit here includes its original charge and additional charge at the site.

The additional charge is calculated according to the refrigerant charging calculation of each kind of Outdoor/Heat source unit, and shall not be over charged at the site. Procedure 1-2-1~3 tells how to confirm maximum refrigerant leakage concentration (Rmax) and how to take countermeasures against a possible leakage.

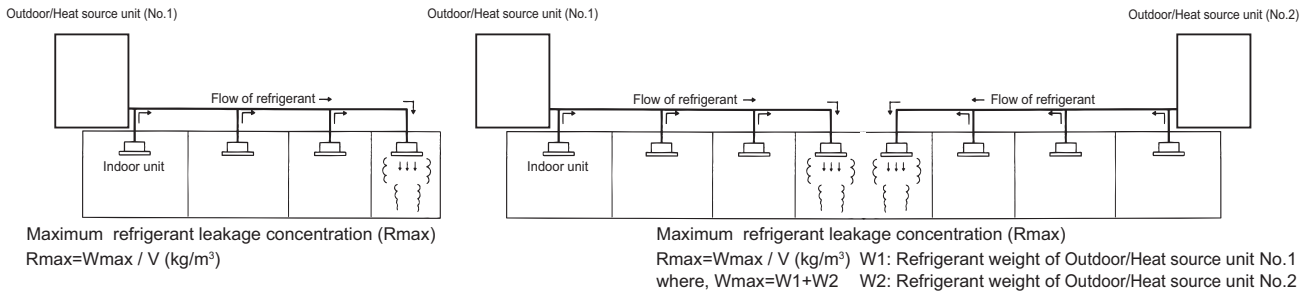

Fig. 1-1 The maximum refrigerant leakage concentration

1-2-1. Find the room capacity (V),

If a room having total opening area more than 0.15% of the floor area at a low position with another room/space, the two rooms/space are considered as one. The total space shall be added up.

1-2-2. Find the possible maximum leakage (Wmax) in the room. If a room has Indoor unit(s) from more than 1 Outdoor/Heat source unit, add up the refrigerant of the Outdoor/Heat source units.

1-2-3. Divide (Wmax) by (V) to get the maximum refrigerant leakage concentration (Rmax).

1-2-4. Find if there is any room in which the maximum refrigerant leakage concentration (Rmax) is over 0.44kg/m³.

If no, then the CITY MULTI is safe against refrigerant leakage.

If yes, following countermeasure is recommended to do at site.

Countermeasure 1: Let-out (making V bigger)

Design an opening of more than 0.15% of the floor area at a low position of the wall to let out the refrigerant whenever leaked. e.g. make the upper and lower seams of door big enough.

Countermeasure 2: Smaller total charge (making Wmax smaller)

e.g. Avoid connecting more than 1 Outdoor/Heat source unit to one room.
 e.g. Using smaller model size but more Outdoor/Heat source units.
 e.g. Shorten the refrigerant piping as much as possible.

Countermeasure 3: Fresh air in from the ceiling (Ventilation)

As the density of the refrigerant is bigger than that of the air. Fresh air supply from the ceiling is better than air exhausting from the ceiling. Fresh air supply solution refers to Fig.1-2~4.

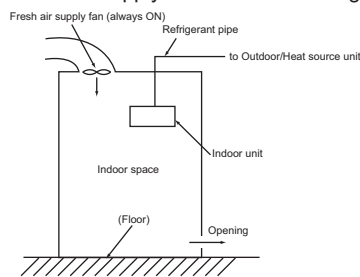

Fig.1-2. Fresh air supply always ON

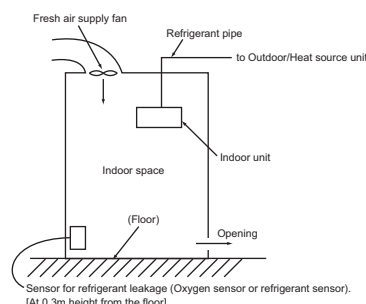

Fig.1-3. Fresh air supply upon sensor action

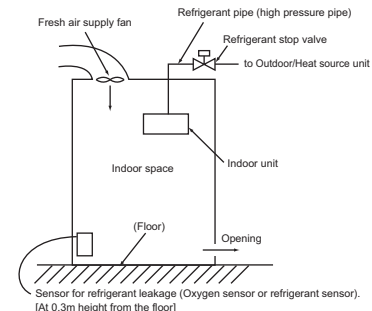

Fig.1-4. Fresh air supply and refrigerant shut-off upon sensor action

Note 1. Countermeasure 3 should be done in a proper way in which the fresh air supply shall be on whenever the leakage happens.

Note 2. In principle, MITSUBISHI ELECTRIC requires proper piping design, installation and air-tight testing after installation to avoid leakage happening. In the area should earthquake happen, anti-vibration measures should be fully considered.

The piping should consider the extension due to the temperature variation.