

HEAT SOURCE UNITS

1. SPECIFICATIONS	2 - 1016
2. EXTERNAL DIMENSIONS	2 - 1028
3. CENTER OF GRAVITY	2 - 1031
4. ELECTRICAL WIRING DIAGRAMS	2 - 1032
5. SOUND LEVELS	2 - 1033
6. CAPACITY TABLES	2 - 1036
6-1. Correction by temperature	2 - 1036
6-2. Correction by total indoor	2 - 1062
6-3. Correction by refrigerant piping length	2 - 1069
6-4. Operation temperature range	2 - 1072
7. SYSTEM DESIGN GUIDE	2 - 1073
7-1. Designing of water circuit system	2 - 1073
7-2. Water piping work	2 - 1085
8. OPTIONAL PARTS	2 - 1089
8-1. JOINT	2 - 1089
8-2. HEADER	2 - 1090
8-3. OUTDOOR TWINNING KIT	2 - 1091

1. SPECIFICATIONS

U11 2nd

Heat Source Model			PQHY-P72ZKMU-A		PQHY-P96ZKMU-A	
			Non-Ducted	Ducted	Non-Ducted	Ducted
Indoor Model			3-phase 3-wire 575 V ±10% 60 Hz		3-phase 3-wire 575 V ±10% 60 Hz	
Power source			3-phase 3-wire 575 V ±10% 60 Hz		3-phase 3-wire 575 V ±10% 60 Hz	
Cooling capacity (Nominal)	*1	BTU/h	72,000		96,000	
		kW	21.1		28.1	
	(575)	Power input	3.75		5.93	
		Current input	4.1		6.6	
	(Rated)	BTU/h	69,000		92,000	
		kW	20.2		27.0	
	(575)	Power input	2.96	3.49	4.26	5.52
		Current input	3.3	3.8	4.7	6.1
Temp. range of cooling	Indoor	W.B.	59~75°F (15~24°C)		59~75°F (15~24°C)	
	Circulating water	°F	50~113°F (10~45°C)		50~113°F (10~45°C)	
Heating capacity (Nominal)	*2	BTU/h	80,000		108,000	
		kW	23.4		31.7	
	(575)	Power input	3.93		6.17	
		Current input	4.3		6.8	
	(Rated)	BTU/h	76,000		103,000	
		kW	22.3		30.2	
	(575)	Power input	3.48	3.66	4.87	5.74
		Current input	3.8	4.0	5.4	6.4
Temp. range of heating	Indoor	D.B.	59~81°F (15~27°C)		59~81°F (15~27°C)	
	Circulating water	°F	50~95°F (10~35°C)		50~95°F (10~35°C)	
Indoor unit connectable			50~130% of heatsource unit capacity		50~130% of heatsource unit capacity	
Model/Quantity			P06~P96/1~15		P06~P96/1~20	
Sound pressure level (measured in anechoic room)			46.0		48.0	
Refrigerant piping diameter	Liquid pipe	in. (mm)	3/8 (9.52) Brazed		3/8 (9.52) Brazed (1/2 (12.7) Brazed, total length >= 90 m)	
	Gas pipe	in. (mm)	3/4 (19.05) Brazed		7/8 (22.2) Brazed	
Minimum Circuit Ampacity			9		12	
Maximum Overcurrent Protection			15		20	
Circulating water	Water flow rate	G/h	1,522		1,522	
		G/min (gpm)	25.4		25.4	
		m ³ /h	5.76		5.76	
		L/min	96		96	
		cfm	3.4		3.4	
	Pressure drop	psi	3.48		3.48	
		kPa	24		24	
	Operating volume range	G/h	1,189 ~ 1,902		1,189 ~ 1,902	
G/min (gpm)		19.8 ~ 31.7		19.8 ~ 31.7		
m ³ /h		4.5 ~ 7.2		4.5 ~ 7.2		
Compressor	Type x Quantity		Inverter scroll hermetic compressor x 1		Inverter scroll hermetic compressor x 1	
	Manufacture		AC&R Works, MITSUBISHI ELECTRIC CORPORATION		AC&R Works, MITSUBISHI ELECTRIC CORPORATION	
	Starting method		Inverter		Inverter	
	Motor output	kW	4.3		6.0	
	Case heater	kW	-		-	
	Lubricant		MEL32		MEL32	
External finish			Galvanized steel sheets		Galvanized steel sheets	
External dimension H x W x D	in.		43-5/16 x 34-11/16 x 21-11/16		43-5/16 x 34-11/16 x 21-11/16	
	mm		1,100 x 880 x 550		1,100 x 880 x 550	
Protection devices	High pressure protection		High pressure sensor, High pressure switch at 4.15 MPa (601 psi)		High pressure sensor, High pressure switch at 4.15 MPa (601 psi)	
	Inverter circuit		Over-heat protection, Over-current protection		Over-heat protection, Over-current protection	
	Compressor		Over-heat protection		Over-heat protection	
Refrigerant	Type x original charge		R410A x 11 lbs + 1 oz (5.0 kg)		R410A x 11 lbs + 1 oz (5.0 kg)	
	Control		LEV and HIC circuit		LEV and HIC circuit	
Net weight		lbs (kg)	408 (185)		408 (185)	
Heat exchanger	Water volume in plate		plate type		plate type	
			G		1.32	
	Water pressure Max.		I		5.0	
			psi		290	
		MPa		2.0		
HIC circuit (HIC: Heat Inter-Changer)			Copper pipe, tube-in-tube structure		Copper pipe, tube-in-tube structure	
Drawing	External		KJ94C549		KJ94C549	
	Wiring		KE94C823		KE94C823	
Standard attachment	Document		-		-	
	Accessory		-		-	
Optional parts			joint: CMY-Y102SS-G2, CMY-Y102LS-G2 Header: CMY-Y104/108/1010C-G		joint: CMY-Y102SS-G2, CMY-Y102LS-G2 Header: CMY-Y104/108/1010C-G	
Remarks			<p>Details on foundation work, duct work, insulation work, electrical wiring, power source switch, and other items shall be referred to the Installation Manual.</p> <p>Due to continuing improvement, above specifications may be subject to change without notice.</p> <p>The ambient temperature of the Heat Source Unit needs to be kept below 104°F.D.B. (40°C.D.B.)</p> <p>The ambient relative humidity of the Heat Source Unit needs to be kept below 80%.</p> <p>The Heat Source Unit should not be installed at outdoor.</p> <p>Be sure to mount a strainer (more than 50 meshes) at the water inlet piping of the unit.</p> <p>Be sure to provide interlocking for the unit operation and water circuit.</p> <p>Install the supplied insulation material to the unused drain-socket.</p> <p>When installing insulation material around both water and refrigerant piping, follow the installation manual.</p>			

Notes:	Unit converter
1.Nominal cooling conditions (Test conditions are based on AHRI 1230) Indoor: 81°F.D.B./66°F.W.B. (27°C.D.B./19°C.W.B.), Water temperature: 86°F (30°C)	BTU/h =kW x 3.412
2.Nominal heating conditions (Test conditions are based on AHRI 1230) Indoor: 68°F.D.B. (20°C.D.B.), Water temperature: 68°F (20°C)	cfm =m ³ /min x 35.31
	lbs =kg/0.4536
	*Above specification data is subject to rounding variation.

WY 575V

1. SPECIFICATIONS

Heat Source Model			PQHY-P120ZKMU-A		
Indoor Model			Non-Ducted	Ducted	
Power source			3-phase 3-wire 575 V ±10% 60 Hz		
Cooling capacity (Nominal)	*1	BTU/h	120,000		
		kW	35.2		
	(575)	Power input	kW	7.90	
		Current input	A	8.8	
	(Rated)	BTU/h	114,000		
		kW	33.4		
	(575)	Power input	kW	6.72	7.35
Current input		A	7.4	8.2	
Temp. range of cooling	Indoor	W.B.	59~75°F (15~24°C)		
	Circulating water	°F	50~113°F (10~45°C)		
Heating capacity (Nominal)	*2	BTU/h	135,000		
		kW	39.6		
	(575)	Power input	kW	7.99	
		Current input	A	8.9	
	(Rated)	BTU/h	129,000		
		kW	37.8		
	(575)	Power input	kW	7.43	7.44
Current input		A	8.2	8.3	
Temp. range of heating	Indoor	D.B.	59~81°F (15~27°C)		
	Circulating water	°F	50~95°F (10~35°C)		
Indoor unit connectable	Total capacity		50~130% of heatsource unit capacity		
	Model/Quantity		P06~P96/1~26		
Sound pressure level (measured in anechoic room)		dB <A>	54.0		
Refrigerant piping diameter	Liquid pipe	in. (mm)	3/8 (9.52) Brazed (1/2 (12.7) Brazed, total length >= 40 m)		
	Gas pipe	in. (mm)	7/8 (22.2) Brazed		
Minimum Circuit Ampacity		A	13		
Maximum Overcurrent Protection		A	22		
Circulating water	Water flow rate	G/h	1,522		
		G/min (gpm)	25.4		
		m³/h	5.76		
		L/min	96		
		cfm	3.4		
	Pressure drop	psi	3.48		
		kPa	24		
Operating volume range	G/h	1,189 ~ 1,902			
	G/min (gpm)	19.8 ~ 31.7			
	m³/h	4.5 ~ 7.2			
Compressor	Type x Quantity		Inverter scroll hermetic compressor x 1		
	Manufacture		AC&R Works, MITSUBISHI ELECTRIC CORPORATION		
	Starting method		Inverter		
	Motor output	kW	7.7		
	Case heater	kW	-		
	Lubricant		MEL32		
External finish		Galvanized steel sheets			
External dimension H x W x D		in.	43-5/16 x 34-11/16 x 21-11/16		
		mm	1,100 x 880 x 550		
Protection devices	High pressure protection		High pressure sensor, High pressure switch at 4.15 MPa (601 psi)		
	Inverter circuit		Over-heat protection, Over-current protection		
	Compressor		Over-heat protection		
Refrigerant	Type x original charge		R410A x 11 lbs + 1 oz (5.0 kg)		
	Control		LEV and HIC circuit		
Net weight	lbs (kg)	408 (185)			
Heat exchanger	Water volume in plate		G	1.32	
			l	5.0	
	Water pressure Max.	psi	290		
		MPa	2.0		
HIC circuit (HIC: Heat Inter-Changer)		Copper pipe, tube-in-tube structure			
Drawing	External		KJ94C549		
	Wiring		KE94C823		
Standard attachment	Document		-		
	Accessory		Details refer to External Drw		
Optional parts		joint: CMY-Y102SS-G2, CMY-Y102LS-G2, CMY-Y202S-G2 Header: CMY-Y104/108/1010C-G			
Remarks		<p>Details on foundation work, duct work, insulation work, electrical wiring, power source switch, and other items shall be referred to the Installation Manual.</p> <p>Due to continuing improvement, above specifications may be subject to change without notice.</p> <p>The ambient temperature of the Heat Source Unit needs to be kept below 104°F.D.B. (40°C.D.B.)</p> <p>The ambient relative humidity of the Heat Source Unit needs to be kept below 80%.</p> <p>The Heat Source Unit should not be installed at outdoor.</p> <p>Be sure to mount a strainer (more than 50 meshes) at the water inlet piping of the unit.</p> <p>Be sure to provide interlocking for the unit operation and water circuit.</p> <p>Install the supplied insulation material to the unused drain-socket.</p> <p>When installing insulation material around both water and refrigerant piping, follow the installation manual.</p>			
Notes:		<p>1.Nominal cooling conditions (Test conditions are based on AHRI 1230) Indoor: 81°F.D.B./66°F.W.B. (27°C.D.B./19°C.W.B.), Water temperature: 86°F (30°C)</p> <p>2.Nominal heating conditions (Test conditions are based on AHRI 1230) Indoor: 68°F.D.B. (20°C.D.B.), Water temperature: 68°F (20°C)</p>			
		<p>Unit converter</p> <p>BTU/h =kW x 3,412</p> <p>cfm =m³/min x 35.31</p> <p>lbs =kg/0.4536</p> <p>*Above specification data is subject to rounding variation.</p>			

WY 575V

1. SPECIFICATIONS

U11 2nd

Heat Source Model			PQHY-P144ZSKMU-A			
Indoor Model			Non-Ducted			
Power source			3-phase 3-wire 575 V ±10% 60 Hz			
Cooling capacity (Nominal)	*1	BTU/h	144,000			
		kW	42.2			
	(575)	Power input	9.21			
		Current input	10.2			
	(Rated)	BTU/h	137,000			
		kW	40.2			
	(575)	Power input	6.47	8.57		
		Current input	7.2	9.5		
	Temp. range of cooling	Indoor	W.B.	59~75°F (15~24°C)		
		Circulating water	°F	50~113°F (10~45°C)		
Heating capacity (Nominal)	*2	BTU/h	160,000			
		kW	46.9			
	(575)	Power input	8.78			
		Current input	9.7			
	(Rated)	BTU/h	152,000			
		kW	44.5			
	(575)	Power input	7.51	8.17		
		Current input	8.3	9.1		
	Temp. range of heating	Indoor	D.B.	59~81°F (15~27°C)		
		Circulating water	°F	50~95°F (10~35°C)		
Indoor unit connectable	Total capacity	50~130% of heat source unit capacity				
	Model/Quantity	P06-P96/1~31				
Sound pressure level (measured in anechoic room)	dB <A>	49.0				
Refrigerant piping diameter	Liquid pipe	in. (mm)	1/2 (12.7) Brazed			
	Gas pipe	in. (mm)	1-1/8 (28.58) Brazed			

Set Model			PQHY-P72ZKMU-A			PQHY-P72ZKMU-A			
Model			PQHY-P72ZKMU-A			PQHY-P72ZKMU-A			
Minimum Circuit Ampacity			9			9			
Maximum Overcurrent Protection			15			15			
Circulating water	Water flow rate	G/h	1,522 + 1,522						
		G/min (gpm)	25.4 + 25.4						
		m ³ /h	5.76 + 5.76						
		L/min	96 + 96						
		cfm	3.4 + 3.4						
	Pressure drop	psi	3.48						
		kPa	24						
Operating volume range	G/h	1,189 + 1,189 ~ 1,902 + 1,902							
	G/min (gpm)	19.8 + 19.8 ~ 31.7 + 31.7							
	m ³ /h	4.5 + 4.5 ~ 7.2 + 7.2							
Compressor	Type x Quantity			Inverter scroll hermetic compressor x 1			Inverter scroll hermetic compressor x 1		
	Manufacture			AC&R Works, MITSUBISHI ELECTRIC CORPORATION			AC&R Works, MITSUBISHI ELECTRIC CORPORATION		
	Starting method			Inverter			Inverter		
	Motor output		kW	4.3			4.3		
	Case heater		kW	-			-		
	Lubricant			MEL32			MEL32		
External finish			Galvanized steel sheets			Galvanized steel sheets			
External dimension H x W x D	in.		43-5/16 x 34-11/16 x 21-11/16			43-5/16 x 34-11/16 x 21-11/16			
	mm		1,100 x 880 x 550			1,100 x 880 x 550			
Protection devices	High pressure protection		High pressure sensor, High pressure switch at 4.15 MPa (601 psi)			High pressure sensor, High pressure switch at 4.15 MPa (601 psi)			
	Inverter circuit		Over-heat protection, Over-current protection			Over-heat protection, Over-current protection			
	Compressor		Over-heat protection			Over-heat protection			
Refrigerant	Type x original charge		R410A x 11 lbs + 1 oz (5.0 kg)			R410A x 11 lbs + 1 oz (5.0 kg)			
	Control		LEV and HIC circuit						
Net weight		lbs (kg)	408 (185)			408 (185)			
Heat exchanger	Water volume in plate		plate type			plate type			
			1.32			1.32			
	Water pressure Max.		5.0			5.0			
			290			290			
			2.0			2.0			
HIC circuit (HIC: Heat Inter-Changer)			Copper pipe, tube-in-tube structure			Copper pipe, tube-in-tube structure			
Pipe between unit and distributor	Liquid pipe		in. (mm)			3/8 (9.52) Brazed			
	Gas pipe		in. (mm)			3/4 (19.05) Brazed			
Drawing	External		KJ94G487			KJ94G487			
	Wiring		KE94C823			KE94C823			
Standard attachment	Document		-						
	Accessory		-						
Optional parts			Details refer to External Drw Heat Source Twinning kit: CMY-Y100CBK3 joint: CMY-Y102SS-G2, CMY-Y102LS-G2, CMY-Y202S-G2 Header: CMY-Y104/108/1010C-G						
Remarks			Details on foundation work, duct work, insulation work, electrical wiring, power source switch, and other items shall be referred to the Installation Manual. Due to continuing improvement, above specifications may be subject to change without notice. The ambient temperature of the Heat Source Unit needs to be kept below 104°F.D.B. (40°C.D.B.) The ambient relative humidity of the Heat Source Unit needs to be kept below 80%. The Heat Source Unit should not be installed at outdoor. Be sure to mount a strainer (more than 50 meshes) at the water inlet piping of the unit. Be sure to provide interlocking for the unit operation and water circuit. Install the supplied insulation material to the unused drain-socket. When installing insulation material around both water and refrigerant piping, follow the installation manual.						

Notes:	Unit converter
1. Nominal cooling conditions (Test conditions are based on AHR1 1230) Indoor: 81°F.D.B./66°F.W.B. (27°C.D.B./19°C.W.B.), Water temperature: 86°F (30°C)	BTU/h =kW x 3.412
2. Nominal heating conditions (Test conditions are based on AHR1 1230) Indoor: 68°F.D.B. (20°C.D.B.), Water temperature: 68°F (20°C)	cfm =m ³ /min x 35.31
	lbs =kg/0.4536
	*Above specification data is subject to rounding variation.

WY 575V

1. SPECIFICATIONS

U11 2nd

Heat Source Model		PQHY-P168ZSKMU-A		
Indoor Model		Non-Ducted	Ducted	
Power source		3-phase 3-wire 575 V ±10% 60 Hz		
Cooling capacity (Nominal)	*1	BTU/h	168,000	
		kW	49.2	
	(575)	Power input	kW	10.67
		Current input	A	11.9
	(Rated)		BTU/h	161,000
			kW	47.2
(575)	Power input	kW	8.48	
	Current input	A	9.4	
Temp. range of cooling	Indoor	W.B.	59~75°F (15~24°C)	
	Circulating water	°F	50~113°F (10~45°C)	
Heating capacity (Nominal)	*2	BTU/h	188,000	
		kW	55.1	
	(575)	Power input	kW	10.73
		Current input	A	11.9
	(Rated)		BTU/h	179,000
			kW	52.5
(575)	Power input	kW	9.44	
Current input	A	10.5	11.1	
Temp. range of heating	Indoor	D.B.	59~81°F (15~27°C)	
	Circulating water	°F	50~95°F (10~35°C)	
Indoor unit connectable	Total capacity	50~130% of heat source unit capacity		
	Model/Quantity	P06~P96/1~36		
Sound pressure level (measured in anechoic room)	dB <A>	50.0		
Refrigerant piping diameter	Liquid pipe	in. (mm)	5/8 (15.88) Brazed	
	Gas pipe	in. (mm)	1-1/8 (28.58) Brazed	

Set Model		PQHY-P96ZKMU-A		PQHY-P72ZKMU-A	
Model		PQHY-P96ZKMU-A		PQHY-P72ZKMU-A	
Minimum Circuit Ampacity	A	12		9	
Maximum Overcurrent Protection	A	20		15	
Circulating water	Water flow rate	G/h	1,522 + 1,522		
		G/min (gpm)	25.4 + 25.4		
		m ³ /h	5.76 + 5.76		
		L/min	96 + 96		
		cfm	3.4 + 3.4		
	Pressure drop	psi	3.48	3.48	
	kPa	24	24		
Operating volume range	G/h	1,189 + 1,189 ~ 1,902 + 1,902			
	G/min (gpm)	19.8 + 19.8 ~ 31.7 + 31.7			
	m ³ /h	4.5 + 4.5 ~ 7.2 + 7.2			
Compressor	Type x Quantity	Inverter scroll hermetic compressor x 1		Inverter scroll hermetic compressor x 1	
	Manufacture	AC&R Works, MITSUBISHI ELECTRIC CORPORATION		AC&R Works, MITSUBISHI ELECTRIC CORPORATION	
	Starting method	Inverter		Inverter	
	Motor output	kW	6.0	4.3	
	Case heater	kW	-	-	
	Lubricant		MEL32	MEL32	
External finish		Galvanized steel sheets		Galvanized steel sheets	
External dimension H x W x D	in.	43-5/16 x 34-11/16 x 21-11/16		43-5/16 x 34-11/16 x 21-11/16	
	mm	1,100 x 880 x 550		1,100 x 880 x 550	
Protection devices	High pressure protection	High pressure sensor, High pressure switch at 4.15 MPa (601 psi)		High pressure sensor, High pressure switch at 4.15 MPa (601 psi)	
	Inverter circuit	Over-heat protection, Over-current protection		Over-heat protection, Over-current protection	
	Compressor	Over-heat protection		Over-heat protection	
Refrigerant	Type x original charge	R410A x 11 lbs + 1 oz (5.0 kg)		R410A x 11 lbs + 1 oz (5.0 kg)	
	Control	LEV and HIC circuit			
Net weight	lbs (kg)	408 (185)		408 (185)	
Heat exchanger	Water volume in plate	G	plate type		plate type
		I	1.32	1.32	
	Water pressure Max.	psi	290	290	
		MPa	2.0	2.0	
HIC circuit (HIC: Heat Inter-Changer)		Copper pipe, tube-in-tube structure		Copper pipe, tube-in-tube structure	
Pipe between unit and distributor	Liquid pipe	in. (mm)	3/8 (9.52) Brazed		3/8 (9.52) Brazed
	Gas pipe	in. (mm)	7/8 (22.2) Brazed		7/8 (22.2) Brazed
Drawing	External	KJ94G487			
	Wiring	KE94C823		KE94C823	
Standard attachment	Document	-			
	Accessory	-			
Optional parts		Details refer to External Drw Heat Source Twinning kit: CMY-Y100CBK3 joint: CMY-Y102SS-G2, CMY-Y102LS-G2, CMY-Y202S-G2 Header: CMY-Y104/108/1010C-G			
Remarks		Details on foundation work, duct work, insulation work, electrical wiring, power source switch, and other items shall be referred to the Installation Manual. Due to continuing improvement, above specifications may be subject to change without notice. The ambient temperature of the Heat Source Unit needs to be kept below 104°F D.B. (40°C D.B.) The ambient relative humidity of the Heat Source Unit needs to be kept below 80%. The Heat Source Unit should not be installed at outdoor. Be sure to mount a strainer (more than 50 meshes) at the water inlet piping of the unit. Be sure to provide interlocking for the unit operation and water circuit. Install the supplied insulation material to the unused drain-socket. When installing insulation material around both water and refrigerant piping, follow the installation manual.			

Notes:	Unit converter
1. Nominal cooling conditions (Test conditions are based on AHRI 1230) Indoor: 81°F D.B./66°F W.B. (27°C D.B./19°C W.B.), Water temperature: 86°F (30°C)	BTU/h = kW x 3.412
2. Nominal heating conditions (Test conditions are based on AHRI 1230) Indoor: 68°F D.B. (20°C D.B.), Water temperature: 68°F (20°C)	cfm = m ³ /min x 35.31
	lbs = kg/0.4536
	*Above specification data is subject to rounding variation.

1. SPECIFICATIONS

U11 2nd

Heat Source Model			PQHY-P192ZSKMU-A		
Indoor Model			Non-Ducted		Ducted
Power source			3-phase 3-wire 575 V ±10% 60 Hz		
Cooling capacity (Nominal)	*1	BTU/h	192,000		
		kW	56.3		
	(575)	Power input	12.60		
		Current input	14.0		
	(Rated)	BTU/h	183,000		
		kW	53.6		
(575)	Power input	10.28	11.73		
	Current input	11.4	13.0		
Temp. range of cooling	Indoor	W.B.	59~75°F (15~24°C)		
	Circulating water	°F	50~113°F (10~45°C)		
Heating capacity (Nominal)	*2	BTU/h	215,000		
		kW	63.0		
	(575)	Power input	13.01		
		Current input	14.5		
	(Rated)	BTU/h	205,000		
		kW	60.1		
(575)	Power input	11.19	12.11		
	Current input	12.4	13.5		
Temp. range of heating	Indoor	D.B.	59~81°F (15~27°C)		
	Circulating water	°F	50~95°F (10~35°C)		
Indoor unit connectable	Total capacity	50~130% of heat source unit capacity			
	Model/Quantity	P06-P96/1~41			
Sound pressure level (measured in anechoic room)		dB <A>	51.0		
Refrigerant piping diameter	Liquid pipe	in. (mm)	5/8 (15.88) Brazed		
	Gas pipe	in. (mm)	1-1/8 (28.58) Brazed		
Set Model					
Model		PQHY-P96ZKMU-A		PQHY-P96ZKMU-A	
Minimum Circuit Ampacity		A	12		12
Maximum Overcurrent Protection		A	20		20
Circulating water	Water flow rate	G/h	1,522 + 1,522		
		G/min (gpm)	25.4 + 25.4		
		m ³ /h	5.76 + 5.76		
		L/min	96 + 96		
		cfm	3.4 + 3.4		
	Pressure drop	psi	3.48		3.48
kPa		24		24	
Operating volume range	G/h	1,189 + 1,189 ~ 1,902 + 1,902			
	G/min (gpm)	19.8 + 19.8 ~ 31.7 + 31.7			
	m ³ /h	4.5 + 4.5 ~ 7.2 + 7.2			
Compressor	Type x Quantity	Inverter scroll hermetic compressor x 1		Inverter scroll hermetic compressor x 1	
	Manufacture	AC&R Works, MITSUBISHI ELECTRIC CORPORATION		AC&R Works, MITSUBISHI ELECTRIC CORPORATION	
	Starting method	Inverter		Inverter	
	Motor output	kW	6.0		6.0
	Case heater	kW	-		-
	Lubricant	MEL32		MEL32	
External finish		Galvanized steel sheets		Galvanized steel sheets	
External dimension H x W x D	in.	43-5/16 x 34-11/16 x 21-11/16		43-5/16 x 34-11/16 x 21-11/16	
	mm	1,100 x 880 x 550		1,100 x 880 x 550	
Protection devices	High pressure protection	High pressure sensor, High pressure switch at 4.15 MPa (601 psi)		High pressure sensor, High pressure switch at 4.15 MPa (601 psi)	
	Inverter circuit	Over-heat protection, Over-current protection		Over-heat protection, Over-current protection	
	Compressor	Over-heat protection		Over-heat protection	
Refrigerant	Type x original charge	R410A x 11 lbs + 1 oz. (5.0 kg)		R410A x 11 lbs + 1 oz. (5.0 kg)	
	Control	LEV and HIC circuit			
Net weight		lbs (kg)	408 (185)		408 (185)
Heat exchanger	Water volume in plate	G	plate type		plate type
		l	1.32		1.32
	Water pressure Max.	psi	290		290
		MPa	2.0		2.0
HIC circuit (HIC: Heat Inter-Changer)		Copper pipe, tube-in-tube structure		Copper pipe, tube-in-tube structure	
Pipe between unit and distributor	Liquid pipe	in. (mm)	3/8 (9.52) Brazed		3/8 (9.52) Brazed
	Gas pipe	in. (mm)	7/8 (22.2) Brazed		7/8 (22.2) Brazed
Drawing	External	KJ94G487			
	Wiring	KE94C823		KE94C823	
Standard attachment	Document	-			
	Accessory	-			
Optional parts		Details refer to External Drw Heat Source Twinning kit: CMY-Y100CBK3 joint: CMY-Y102SS-G2, CMY-Y102LS-G2, CMY-Y202S-G2, CMY-Y302S-G2 Header: CMY-Y104/108/1010C-G			
Remarks		Details on foundation work, duct work, insulation work, electrical wiring, power source switch, and other items shall be referred to the Installation Manual. Due to continuing improvement, above specifications may be subject to change without notice. The ambient temperature of the Heat Source Unit needs to be kept below 104°F.D.B. (40°C.D.B.) The ambient relative humidity of the Heat Source Unit needs to be kept below 80%. The Heat Source Unit should not be installed at outdoor. Be sure to mount a strainer (more than 50 meshes) at the water inlet piping of the unit. Be sure to provide interlocking for the unit operation and water circuit. Install the supplied insulation material to the unused drain-socket. When installing insulation material around both water and refrigerant piping, follow the installation manual.			

Notes:		Unit converter
1.Nominal cooling conditions (Test conditions are based on AHRI 1230) Indoor: 81°F.D.B./66°F.W.B. (27°C.D.B./19°C.W.B.), Water temperature: 86°F (30°C)		BTU/h =kW x 3.412
2.Nominal heating conditions (Test conditions are based on AHRI 1230) Indoor: 68°F.D.B. (20°C.D.B.), Water temperature: 68°F (20°C)		cfm =m ³ /min x 35.31
		lbs =kg/0.4536
		*Above specification data is subject to rounding variation.

WY 575V

Heat Source Model		PQHY-P216ZSKMU-A		
Indoor Model		Non-Ducted	Ducted	
Power source		3-phase 3-wire 575 V ±10% 60 Hz		
Cooling capacity (Nominal)	*1	BTU/h	216,000	
		kW	63.3	
	(575)	Power input	kW	14.60
		Current input	A	16.2
	(Rated)		BTU/h	206,000
			kW	60.4
(575)	Power input	kW	12.77	
	Current input	A	14.2	
Temp. range of cooling	Indoor	W.B.	59~75°F (15~24°C)	
	Circulating water	°F	50~113°F (10~45°C)	
Heating capacity (Nominal)	*2	BTU/h	243,000	
		kW	71.2	
	(575)	Power input	kW	14.97
		Current input	A	16.7
	(Rated)		BTU/h	232,000
			kW	68.0
(575)	Power input	kW	13.88	
Current input	A	15.4	13.93	
Temp. range of heating	Indoor	D.B.	59~81°F (15~27°C)	
	Circulating water	°F	50~95°F (10~35°C)	
Indoor unit connectable	Total capacity	50~130% of heat source unit capacity		
	Model/Quantity	P06~P96/2~46		
Sound pressure level (measured in anechoic room)	dB <A>	55.0		
Refrigerant piping diameter	Liquid pipe	in. (mm)	5/8 (15.88) Brazed	
	Gas pipe	in. (mm)	1-1/8 (28.58) Brazed	

Set Model		PQHY-P120ZKMU-A		PQHY-P96ZKMU-A	
Model		PQHY-P120ZKMU-A		PQHY-P96ZKMU-A	
Minimum Circuit Ampacity	A	13		12	
Maximum Overcurrent Protection	A	22		20	
Circulating water	Water flow rate	G/h	1,522 + 1,522		
		G/min (gpm)	25.4 + 25.4		
		m ³ /h	5.76 + 5.76		
		L/min	96 + 96		
		cfm	3.4 + 3.4		
	Pressure drop	psi	3.48	3.48	
	kPa	24	24		
Operating volume range	G/h	1,189 + 1,189 ~ 1,902 + 1,902			
	G/min (gpm)	19.8 + 19.8 ~ 31.7 + 31.7			
	m ³ /h	4.5 + 4.5 ~ 7.2 + 7.2			
Compressor	Type x Quantity	Inverter scroll hermetic compressor x 1		Inverter scroll hermetic compressor x 1	
	Manufacture	AC&R Works, MITSUBISHI ELECTRIC CORPORATION		AC&R Works, MITSUBISHI ELECTRIC CORPORATION	
	Starting method	Inverter		Inverter	
	Motor output	kW	7.7	6.0	
	Case heater	kW	-	-	
	Lubricant		MEL32		MEL32
External finish		Galvanized steel sheets		Galvanized steel sheets	
External dimension H x W x D	in.	43-5/16 x 34-11/16 x 21-11/16		43-5/16 x 34-11/16 x 21-11/16	
	mm	1,100 x 880 x 550		1,100 x 880 x 550	
Protection devices	High pressure protection	High pressure sensor, High pressure switch at 4.15 MPa (601 psi)		High pressure sensor, High pressure switch at 4.15 MPa (601 psi)	
	Inverter circuit	Over-heat protection, Over-current protection		Over-heat protection, Over-current protection	
	Compressor	Over-heat protection		Over-heat protection	
Refrigerant	Type x original charge	R410A x 11 lbs + 1 oz (5.0 kg)		R410A x 11 lbs + 1 oz (5.0 kg)	
	Control	LEV and HIC circuit			
Net weight	lbs (kg)	408 (185)		408 (185)	
Heat exchanger	Water volume in plate	G	plate type		plate type
		l	1.32	1.32	
	Water pressure Max.	psi	290	290	
		MPa	2.0	2.0	
HIC circuit (HIC: Heat Inter-Changer)		Copper pipe, tube-in-tube structure		Copper pipe, tube-in-tube structure	
Pipe between unit and distributor	Liquid pipe	in. (mm)	1/2 (12.7) Brazed		1/2 (12.7) Brazed
	Gas pipe	in. (mm)	7/8 (22.2) Brazed		7/8 (22.2) Brazed
Drawing	External	KJ94G487			
	Wiring	KE94C823		KE94C823	
Standard attachment	Document	-			
	Accessory	Details refer to External Drw			
Optional parts		Heat Source Twinning kit: CMY-Y100CBK3 joint: CMY-Y102SS-G2, CMY-Y102LS-G2, CMY-Y202S-G2, CMY-Y302S-G2 Header: CMY-Y104/108/1010C-G			
Remarks		Details on foundation work, duct work, insulation work, electrical wiring, power source switch, and other items shall be referred to the Installation Manual. Due to continuing improvement, above specifications may be subject to change without notice. The ambient temperature of the Heat Source Unit needs to be kept below 104°F.D.B. (40°C.D.B.) The ambient relative humidity of the Heat Source Unit needs to be kept below 80%. The Heat Source Unit should not be installed at outdoor. Be sure to mount a strainer (more than 50 meshes) at the water inlet piping of the unit. Be sure to provide interlocking for the unit operation and water circuit. Install the supplied insulation material to the unused drain-socket. When installing insulation material around both water and refrigerant piping, follow the installation manual.			

Notes:	Unit converter
1.Nominal cooling conditions (Test conditions are based on AHR1 1230) Indoor: 81°F.D.B./66°F.W.B. (27°C.D.B./19°C.W.B.), Water temperature: 86°F (30°C)	BTU/h =kW x 3,412
2.Nominal heating conditions (Test conditions are based on AHR1 1230) Indoor: 68°F.D.B. (20°C.D.B.), Water temperature: 68°F (20°C)	cfm =m ³ /min x 35.31
	lbs =kg/0.4536
	*Above specification data is subject to rounding variation.

1. SPECIFICATIONS

U11 2nd

Heat Source Model			PQHY-P240ZSKMU-A		
Indoor Model			Non-Ducted		Ducted
Power source			3-phase 3-wire 575 V ±10% 60 Hz		
Cooling capacity (Nominal)	*1	BTU/h	240,000		
		kW	70.3		
	(575)	Power input	18.17		
		Current input	20.2		
	(Rated)	BTU/h	228,000		
		kW	66.8		
	(575)	Power input	15.63	16.91	
		Current input	17.4	18.8	
Temp. range of cooling	Indoor	W.B.	59~75°F (15~24°C)		
	Circulating water	°F	50~113°F (10~45°C)		
Heating capacity (Nominal)	*2	BTU/h	270,000		
		kW	79.1		
	(575)	Power input	17.14		
		Current input	19.1		
	(Rated)	BTU/h	258,000		
		kW	75.6		
	(575)	Power input	16.78	15.95	
		Current input	18.7	17.7	
Temp. range of heating	Indoor	D.B.	59~81°F (15~27°C)		
	Circulating water	°F	50~95°F (10~35°C)		
Indoor unit connectable	Total capacity	50~130% of heat source unit capacity			
	Model/Quantity	P06-P96/2-50			
Sound pressure level (measured in anechoic room)		dB <A>	57.0		
Refrigerant piping diameter	Liquid pipe	in. (mm)	5/8 (15.88) Brazed		
	Gas pipe	in. (mm)	1-1/8 (28.58) Brazed		
Set Model					
Model		PQHY-P120ZKMU-A		PQHY-P120ZKMU-A	
Minimum Circuit Ampacity		A	13		13
Maximum Overcurrent Protection		A	22		22
Circulating water	Water flow rate	G/h	1,522 + 1,522		
		G/min (gpm)	25.4 + 25.4		
		m ³ /h	5.76 + 5.76		
		L/min	96 + 96		
		cfm	3.4 + 3.4		
	Pressure drop	psi	3.48		3.48
		kPa	24		24
	Operating volume range	G/h	1,189 + 1,189 ~ 1,902 + 1,902		
G/min (gpm)		19.8 + 19.8 ~ 31.7 + 31.7			
m ³ /h		4.5 + 4.5 ~ 7.2 + 7.2			
Compressor	Type x Quantity	Inverter scroll hermetic compressor x 1		Inverter scroll hermetic compressor x 1	
	Manufacture	AC&R Works, MITSUBISHI ELECTRIC CORPORATION		AC&R Works, MITSUBISHI ELECTRIC CORPORATION	
	Starting method	Inverter		Inverter	
	Motor output	kW	7.7		7.7
	Case heater	kW	-		-
	Lubricant	MEL32		MEL32	
External finish		Galvanized steel sheets		Galvanized steel sheets	
External dimension H x W x D	in.	43-5/16 x 34-11/16 x 21-11/16		43-5/16 x 34-11/16 x 21-11/16	
	mm	1,100 x 880 x 550		1,100 x 880 x 550	
Protection devices	High pressure protection	High pressure sensor, High pressure switch at 4.15 MPa (601 psi)		High pressure sensor, High pressure switch at 4.15 MPa (601 psi)	
	Inverter circuit	Over-heat protection, Over-current protection		Over-heat protection, Over-current protection	
	Compressor	Over-heat protection		Over-heat protection	
Refrigerant	Type x original charge	R410A x 11 lbs + 1 oz. (5.0 kg)		R410A x 11 lbs + 1 oz. (5.0 kg)	
	Control	LEV and HIC circuit			
Net weight		lbs (kg)	408 (185)		408 (185)
Heat exchanger	Water volume in plate	G	plate type		plate type
		l	1.32		1.32
	Water pressure Max.	psi	290		290
		MPa	2.0		2.0
HIC circuit (HIC: Heat Inter-Changer)		Copper pipe, tube-in-tube structure		Copper pipe, tube-in-tube structure	
Pipe between unit and distributor	Liquid pipe	in. (mm)	1/2 (12.7) Brazed		1/2 (12.7) Brazed
	Gas pipe	in. (mm)	7/8 (22.2) Brazed		7/8 (22.2) Brazed
Drawing	External	KJ94G487			
	Wiring	KE94C823		KE94C823	
Standard attachment	Document	-			
	Accessory	-			
Optional parts		Details refer to External Drw Heat Source Twinning kit: CMY-Y100CBK3 joint: CMY-Y102SS-G2, CMY-Y102LS-G2, CMY-Y202S-G2, CMY-Y302S-G2 Header: CMY-Y104/108/1010C-G			
Remarks		Details on foundation work, duct work, insulation work, electrical wiring, power source switch, and other items shall be referred to the Installation Manual. Due to continuing improvement, above specifications may be subject to change without notice. The ambient temperature of the Heat Source Unit needs to be kept below 104°F.D.B. (40°C.D.B.) The ambient relative humidity of the Heat Source Unit needs to be kept below 80%. The Heat Source Unit should not be installed at outdoor. Be sure to mount a strainer (more than 50 meshes) at the water inlet piping of the unit. Be sure to provide interlocking for the unit operation and water circuit. Install the supplied insulation material to the unused drain-socket. When installing insulation material around both water and refrigerant piping, follow the installation manual.			

Notes:		Unit converter	
1.Nominal cooling conditions (Test conditions are based on AHRI 1230) Indoor: 81°F.D.B./66°F.W.B. (27°C.D.B./19°C.W.B.), Water temperature: 86°F (30°C)		BTU/h =kW x 3.412	
2.Nominal heating conditions (Test conditions are based on AHRI 1230) Indoor: 68°F.D.B. (20°C.D.B.), Water temperature: 68°F (20°C)		cfm =m ³ /min x 35.31	
		lbs =kg/0.4536	
*Above specification data is subject to rounding variation.			

WY 575V

1. SPECIFICATIONS

Heat Source Model			PQHY-P264ZSKMU-A		
Indoor Model			Non-Ducted		Ducted
Power source			3-phase 3-wire 575 V ±10% 60 Hz		
Cooling capacity (Nominal)	*1	BTU/h	264,000		
		kW	77.4		
		(575) Power input kW	17.96		
	(Rated)	(575) Current input A	20.0		
		BTU/h	252,000		
		kW	73.9		
(575)	Power input kW	14.61	16.71		
	Current input A	16.2	18.6		
Temp. range of cooling			Indoor W.B. 59~75°F (15~24°C) Circulating water °F 50~113°F (10~45°C)		
Heating capacity (Nominal)	*2	BTU/h	295,000		
		kW	86.5		
		(575) Power input kW	17.27		
	(Rated)	(575) Current input A	19.2		
		BTU/h	281,000		
		kW	82.4		
(575)	Power input kW	15.52	16.07		
	Current input A	17.3	17.9		
Temp. range of heating			Indoor D.B. 59~81°F (15~27°C) Circulating water °F 50~95°F (10~35°C)		
Indoor unit connectable			Total capacity 50~130% of heat source unit capacity Model/Quantity P06~P96/2~50		
Sound pressure level (measured in anechoic room)			dB <A> 52.0		
Refrigerant piping diameter			Liquid pipe in. (mm) 3/4 (19.05) Brazed Gas pipe in. (mm) 1-3/8 (34.93) Brazed		

Set Model			PQHY-P96ZKMU-A	PQHY-P96ZKMU-A	PQHY-P72ZKMU-A
Model			PQHY-P96ZKMU-A	PQHY-P96ZKMU-A	PQHY-P72ZKMU-A
Minimum Circuit Ampacity			A 12	12	9
Maximum Overcurrent Protection			A 20	20	15
Circulating water	Water flow rate	G/h	1,522 + 1,522 + 1,522		
		G/min (gpm)	25.4 + 25.4 + 25.4		
		m ³ /h	5.76 + 5.76 + 5.76		
		L/min	96 + 96 + 96		
		cfm	3.4 + 3.4 + 3.4		
	Pressure drop	psi	3.48	3.48	3.48
	kPa	24	24	24	
Operating volume range	G/h	1,189 + 1,189 + 1,189 ~ 1,902 + 1,902 + 1,902			
	G/min (gpm)	19.8 + 19.8 + 19.8 ~ 31.7 + 31.7 + 31.7			
	m ³ /h	4.5 + 4.5 + 4.5 ~ 7.2 + 7.2 + 7.2			
Compressor	Type x Quantity		Inverter scroll hermetic compressor x 1	Inverter scroll hermetic compressor x 1	Inverter scroll hermetic compressor x 1
	Manufacture		AC&R Works, MITSUBISHI ELECTRIC CORPORATION	AC&R Works, MITSUBISHI ELECTRIC CORPORATION	AC&R Works, MITSUBISHI ELECTRIC CORPORATION
	Starting method		Inverter	Inverter	Inverter
	Motor output	kW	6.0	6.0	4.3
	Case heater	kW	-	-	-
	Lubricant		MEL32	MEL32	MEL32
External finish			Galvanized steel sheets	Galvanized steel sheets	Galvanized steel sheets
External dimension H x W x D			in. 43-5/16 x 34-11/16 x 21-11/16 mm 1,100 x 880 x 550	in. 43-5/16 x 34-11/16 x 21-11/16 mm 1,100 x 880 x 550	in. 43-5/16 x 34-11/16 x 21-11/16 mm 1,100 x 880 x 550
Protection devices	High pressure protection		High pressure sensor, High pressure switch at 4.15 MPa (601 psi)	High pressure sensor, High pressure switch at 4.15 MPa (601 psi)	High pressure sensor, High pressure switch at 4.15 MPa (601 psi)
	Inverter circuit		Over-heat protection, Over-current protection	Over-heat protection, Over-current protection	Over-heat protection, Over-current protection
	Compressor		Over-heat protection	Over-heat protection	Over-heat protection
Refrigerant	Type x original charge		R410A x 11 lbs + 1 oz. (5.0 kg)	R410A x 11 lbs + 1 oz. (5.0 kg)	R410A x 11 lbs + 1 oz. (5.0 kg)
	Control		LEV and HIC circuit		
Net weight			lbs (kg) 408 (185)	408 (185)	408 (185)
Heat exchanger	Water volume in plate		plate type 1.32	plate type 1.32	plate type 1.32
			l 5.0	5.0	5.0
	Water pressure Max.		psi 290	290	290
			MPa 2.0	2.0	2.0
HIC circuit (HIC: Heat Inter-Changer)			Copper pipe, tube-in-tube structure	Copper pipe, tube-in-tube structure	Copper pipe, tube-in-tube structure
Pipe between unit and distributor	Liquid pipe	in. (mm)	3/8 (9.52) Brazed	3/8 (9.52) Brazed	3/8 (9.52) Brazed
	Gas pipe	in. (mm)	7/8 (22.2) Brazed	7/8 (22.2) Brazed	7/8 (22.2) Brazed
Drawing	External		KJ94G488		
	Wiring		KE94C823	KE94C823	KE94C823
Standard attachment	Document		-		
	Accessory		Details refer to External Drw		
Optional parts			Heat Source Twinning kit: CMY-Y300CBK2 joint: CMY-Y102SS-G2, CMY-Y102LS-G2, CMY-Y202S-G2, CMY-Y302S-G2 Header: CMY-Y104/108/1010C-G		
Remarks			Details on foundation work, duct work, insulation work, electrical wiring, power source switch, and other items shall be referred to the Installation Manual. Due to continuing improvement, above specifications may be subject to change without notice. The ambient temperature of the Heat Source Unit needs to be kept below 104°F D.B. (40°C D.B.) The ambient relative humidity of the Heat Source Unit needs to be kept below 80%. The Heat Source Unit should not be installed at outdoor. Be sure to mount a strainer (more than 50 meshes) at the water inlet piping of the unit. Be sure to provide interlocking for the unit operation and water circuit. Install the supplied insulation material to the unused drain-socket. When installing insulation material around both water and refrigerant piping, follow the installation manual.		

Notes:	Unit converter
1. Nominal cooling conditions (Test conditions are based on AHRI 1230) Indoor: 81°F D.B./66°F W.B. (27°C D.B./19°C W.B.), Water temperature: 86°F (30°C)	BTU/h = kW x 3.412
2. Nominal heating conditions (Test conditions are based on AHRI 1230) Indoor: 68°F D.B. (20°C D.B.), Water temperature: 68°F (20°C)	cfm = m ³ /min x 35.31
	lbs = kg/0.4536
	*Above specification data is subject to rounding variation.

1. SPECIFICATIONS

U11 2nd

Heat Source Model		PQHY-P288ZSKMU-A		
Indoor Model		Non-Ducted		Ducted
Power source		3-phase 3-wire 575 V ±10% 60 Hz		
Cooling capacity (Nominal)	*1	BTU/h	288,000	
		kW	84.4	
	(575)	Power input	19.98	
		Current input	22.2	
	(Rated)	BTU/h	275,000	
		kW	80.6	
(575)	Power input	16.42	18.59	
	Current input	18.3	20.7	
Temp. range of cooling	Indoor	W.B. 59~75°F (15~24°C)		
	Circulating water	°F 50~113°F (10~45°C)		
Heating capacity (Nominal)	*2	BTU/h	323,000	
		kW	94.7	
	(575)	Power input	19.55	
		Current input	21.8	
	(Rated)	BTU/h	308,000	
		kW	90.3	
(575)	Power input	17.31	18.19	
	Current input	19.3	20.2	
Temp. range of heating	Indoor	D.B. 59~81°F (15~27°C)		
	Circulating water	°F 50~95°F (10~35°C)		
Indoor unit connectable	Total capacity	50~130% of heat source unit capacity		
	Model/Quantity	P06~P96/2~50		
Sound pressure level (measured in anechoic room)	dB <A>	53.0		
Refrigerant piping diameter	Liquid pipe	in. (mm) 3/4 (19.05) Brazed		
	Gas pipe	in. (mm) 1-3/8 (34.93) Brazed		

Set Model		PQHY-P96ZKMU-A			
Model		PQHY-P96ZKMU-A	PQHY-P96ZKMU-A	PQHY-P96ZKMU-A	
Minimum Circuit Ampacity		A 12	12	12	
Maximum Overcurrent Protection		A 20	20	20	
Circulating water	Water flow rate	G/h	1,522 + 1,522 + 1,522		
		G/min (gpm)	25.4 + 25.4 + 25.4		
		m ³ /h	5.76 + 5.76 + 5.76		
		L/min	96 + 96 + 96		
		cfm	3.4 + 3.4 + 3.4		
	Pressure drop	psi	3.48	3.48	3.48
kPa		24	24	24	
Operating volume range	G/h	1,189 + 1,189 + 1,189 ~ 1,902 + 1,902 + 1,902			
	G/min (gpm)	19.8 + 19.8 + 19.8 ~ 31.7 + 31.7 + 31.7			
	m ³ /h	4.5 + 4.5 + 4.5 ~ 7.2 + 7.2 + 7.2			
Compressor	Type x Quantity		Inverter scroll hermetic compressor x 1	Inverter scroll hermetic compressor x 1	Inverter scroll hermetic compressor x 1
	Manufacture		AC&R Works, MITSUBISHI ELECTRIC CORPORATION	AC&R Works, MITSUBISHI ELECTRIC CORPORATION	AC&R Works, MITSUBISHI ELECTRIC CORPORATION
	Starting method		Inverter	Inverter	Inverter
	Motor output	kW	6.0	6.0	6.0
	Case heater	kW	-	-	-
	Lubricant		MEL32	MEL32	MEL32
External finish		Galvanized steel sheets	Galvanized steel sheets	Galvanized steel sheets	
External dimension H x W x D	in.	43-5/16 x 34-11/16 x 21-11/16	43-5/16 x 34-11/16 x 21-11/16	43-5/16 x 34-11/16 x 21-11/16	
	mm	1,100 x 880 x 550	1,100 x 880 x 550	1,100 x 880 x 550	
Protection devices	High pressure protection		High pressure sensor, High pressure switch at 4.15 MPa (601 psi)	High pressure sensor, High pressure switch at 4.15 MPa (601 psi)	High pressure sensor, High pressure switch at 4.15 MPa (601 psi)
	Inverter circuit		Over-heat protection, Over-current protection	Over-heat protection, Over-current protection	Over-heat protection, Over-current protection
	Compressor		Over-heat protection	Over-heat protection	Over-heat protection
Refrigerant	Type x original charge		R410A x 11 lbs + 1 oz (5.0 kg)	R410A x 11 lbs + 1 oz (5.0 kg)	R410A x 11 lbs + 1 oz (5.0 kg)
	Control		LEV and HIC circuit		
Net weight	lbs (kg)	408 (185)	408 (185)	408 (185)	
Heat exchanger	Water volume in plate		plate type		plate type
			G	1.32	1.32
	Water pressure Max.		plate type		plate type
			l	5.0	5.0
		plate type		plate type	
		psi	290	290	
		MPa		MPa	
		2.0		2.0	
HIC circuit (HIC: Heat Inter-Changer)		Copper pipe, tube-in-tube structure			
Pipe between unit and distributor	Liquid pipe	in. (mm) 3/8 (9.52) Brazed			
	Gas pipe	in. (mm) 7/8 (22.2) Brazed			
Drawing	External	KJ94G488			
	Wiring	KE94C823	KE94C823	KE94C823	
Standard attachment	Document	-			
	Accessory	Details refer to External Drw			
Optional parts	Heat Source Twinning kit: CMY-Y300CBK2 joint: CMY-Y102SS-G2, CMY-Y102LS-G2, CMY-Y202S-G2, CMY-Y302S-G2 Header: CMY-Y104/108/1010C-G				
Remarks	Details on foundation work, duct work, insulation work, electrical wiring, power source switch, and other items shall be referred to the Installation Manual. Due to continuing improvement, above specifications may be subject to change without notice. The ambient temperature of the Heat Source Unit needs to be kept below 104°F D.B. (40°C D.B.) The ambient relative humidity of the Heat Source Unit needs to be kept below 80%. The Heat Source Unit should not be installed at outdoor. Be sure to mount a strainer (more than 50 meshes) at the water inlet piping of the unit. Be sure to provide interlocking for the unit operation and water circuit. Install the supplied insulation material to the unused drain-socket. When installing insulation material around both water and refrigerant piping, follow the installation manual.				

Notes:	Unit converter
1. Nominal cooling conditions (Test conditions are based on AHRI 1230) Indoor: 81°F D.B./66°F W.B. (27°C D.B./19°C W.B.), Water temperature: 86°F (30°C)	BTU/h = kW x 3.412
2. Nominal heating conditions (Test conditions are based on AHRI 1230) Indoor: 68°F D.B. (20°C D.B.), Water temperature: 68°F (20°C)	cfm = m ³ /min x 35.31
	lbs = kg/0.4536
	*Above specification data is subject to rounding variation.

1. SPECIFICATIONS

Heat Source Model			PQHY-P312ZSKMU-A		
Indoor Model			Non-Ducted		Ducted
Power source			3-phase 3-wire 575 V ±10% 60 Hz		
Cooling capacity (Nominal)	*1	BTU/h	312,000		
		kW	91.4		
	(575)	Power input	22.41		
		Current input	25.0		
	(Rated)	BTU/h	297,000		
		kW	87.0		
(575)	Power input	19.28	20.85		
	Current input	21.5	23.2		
Temp. range of cooling	Indoor	W.B.	59~75°F (15~24°C)		
	Circulating water	°F	50~113°F (10~45°C)		
Heating capacity (Nominal)	*2	BTU/h	350,000		
		kW	102.6		
	(575)	Power input	21.52		
		Current input	24.0		
	(Rated)	BTU/h	334,000		
		kW	97.9		
(575)	Power input	20.10	20.02		
	Current input	22.4	22.3		
Temp. range of heating	Indoor	D.B.	59~81°F (15~27°C)		
	Circulating water	°F	50~95°F (10~35°C)		
Indoor unit connectable	Total capacity	50~130% of heat source unit capacity			
	Model/Quantity	P06-P96/2~50			
Sound pressure level (measured in anechoic room)	dB <A>	56.0			
Refrigerant piping diameter	Liquid pipe	in. (mm)	3/4 (19.05) Brazed		
	Gas pipe	in. (mm)	1-3/8 (34.93) Brazed		

Set Model			PQHY-P120ZKMU-A	PQHY-P96ZKMU-A	PQHY-P96ZKMU-A
Model			PQHY-P120ZKMU-A	PQHY-P96ZKMU-A	PQHY-P96ZKMU-A
Minimum Circuit Ampacity			A	13	12
Maximum Overcurrent Protection			A	22	20
Circulating water	Water flow rate	G/h	1,522 + 1,522 + 1,522		
		G/min (gpm)	25.4 + 25.4 + 25.4		
		m ³ /h	5.76 + 5.76 + 5.76		
		L/min	96 + 96 + 96		
		cfm	3.4 + 3.4 + 3.4		
	Pressure drop	psi	3.48	3.48	3.48
kPa		24	24	24	
Operating volume range	G/h	1,189 + 1,189 + 1,189 ~ 1,902 + 1,902 + 1,902			
	G/min (gpm)	19.8 + 19.8 + 19.8 ~ 31.7 + 31.7 + 31.7			
	m ³ /h	4.5 + 4.5 + 4.5 ~ 7.2 + 7.2 + 7.2			
Compressor	Type x Quantity		Inverter scroll hermetic compressor x 1	Inverter scroll hermetic compressor x 1	Inverter scroll hermetic compressor x 1
	Manufacture		AC&R Works, MITSUBISHI ELECTRIC CORPORATION	AC&R Works, MITSUBISHI ELECTRIC CORPORATION	AC&R Works, MITSUBISHI ELECTRIC CORPORATION
	Starting method		Inverter	Inverter	Inverter
	Motor output	kW	7.7	6.0	6.0
	Case heater	kW	-	-	-
	Lubricant		MEL32	MEL32	MEL32
External finish			Galvanized steel sheets	Galvanized steel sheets	Galvanized steel sheets
External dimension H x W x D			in.	43-5/16 x 34-11/16 x 21-11/16	43-5/16 x 34-11/16 x 21-11/16
			mm	1,100 x 880 x 550	1,100 x 880 x 550
Protection devices	High pressure protection		High pressure sensor, High pressure switch at 4.15 MPa (601 psi)	High pressure sensor, High pressure switch at 4.15 MPa (601 psi)	High pressure sensor, High pressure switch at 4.15 MPa (601 psi)
	Inverter circuit		Over-heat protection, Over-current protection	Over-heat protection, Over-current protection	Over-heat protection, Over-current protection
	Compressor		Over-heat protection	Over-heat protection	Over-heat protection
Refrigerant	Type x original charge		R410A x 11 lbs + 1 oz. (5.0 kg)	R410A x 11 lbs + 1 oz. (5.0 kg)	R410A x 11 lbs + 1 oz. (5.0 kg)
	Control		LEV and HIC circuit		
Net weight			lbs (kg)	408 (185)	408 (185)
Heat exchanger	Water volume in plate		plate type	plate type	plate type
			G	1.32	1.32
	Water pressure Max.		l	5.0	5.0
			psi	290	290
		MPa	2.0	2.0	
HIC circuit (HIC: Heat Inter-Changer)			Copper pipe, tube-in-tube structure	Copper pipe, tube-in-tube structure	Copper pipe, tube-in-tube structure
Pipe between unit and distributor	Liquid pipe	in. (mm)	1/2 (12.7) Brazed	1/2 (12.7) Brazed	1/2 (12.7) Brazed
	Gas pipe	in. (mm)	7/8 (22.2) Brazed	7/8 (22.2) Brazed	7/8 (22.2) Brazed
Drawing	External		KJ94G488		
	Wiring		KE94C823	KE94C823	KE94C823
Standard attachment	Document		-		
	Accessory		Details refer to External Drw		
Optional parts			Heat Source Twinning kit: CMY-Y300CBK2 joint: CMY-Y102SS-G2, CMY-Y102LS-G2, CMY-Y202S-G2, CMY-Y302S-G2 Header: CMY-Y104/108/1010C-G		
Remarks			Details on foundation work, duct work, insulation work, electrical wiring, power source switch, and other items shall be referred to the Installation Manual. Due to continuing improvement, above specifications may be subject to change without notice. The ambient temperature of the Heat Source Unit needs to be kept below 104°F D.B. (40°C D.B.) The ambient relative humidity of the Heat Source Unit needs to be kept below 80%. The Heat Source Unit should not be installed at outdoor. Be sure to mount a strainer (more than 50 meshes) at the water inlet piping of the unit. Be sure to provide interlocking for the unit operation and water circuit. Install the supplied insulation material to the unused drain-socket. When installing insulation material around both water and refrigerant piping, follow the installation manual.		

Notes:	Unit converter
1. Nominal cooling conditions (Test conditions are based on AHRI 1230) Indoor: 81°F D.B./66°F W.B. (27°C D.B./19°C W.B.), Water temperature: 86°F (30°C)	BTU/h = kW x 3.412
2. Nominal heating conditions (Test conditions are based on AHRI 1230) Indoor: 68°F D.B. (20°C D.B.), Water temperature: 68°F (20°C)	cfm = m ³ /min x 35.31
	lbs = kg/0.4536
	*Above specification data is subject to rounding variation.

1. SPECIFICATIONS

U11 2nd

Heat Source Model		PQHY-P336ZSKMU-A			
Indoor Model		Non-Ducted		Ducted	
Power source		3-phase 3-wire 575 V ±10% 60 Hz			
Cooling capacity (Nominal)	*1	BTU/h	336,000		
		kW	98.5		
	(575)	Power input	24.86		
		Current input	27.7		
	(Rated)	BTU/h	320,000		
		kW	93.8		
	(575)	Power input	22.51	23.13	
		Current input	25.1	25.8	
Temp. range of cooling	Indoor	W.B. 59~75°F (15~24°C)			
	Circulating water	°F 50~113°F (10~45°C)			
Heating capacity (Nominal)	*2	BTU/h	378,000		
		kW	110.8		
	(575)	Power input	23.68		
		Current input	26.4		
	(Rated)	BTU/h	361,000		
		kW	105.8		
	(575)	Power input	23.32	22.03	
		Current input	26.0	24.5	
Temp. range of heating	Indoor	D.B. 59~81°F (15~27°C)			
	Circulating water	°F 50~95°F (10~35°C)			
Indoor unit connectable	Total capacity	50~130% of heat source unit capacity			
	Model/Quantity	P06~P96/2~50			
Sound pressure level (measured in anechoic room)	dB <A>	57.5			
Refrigerant piping diameter	Liquid pipe	in. (mm) 3/4 (19.05) Brazed			
	Gas pipe	in. (mm) 1-5/8 (41.28) Brazed			

Set Model		PQHY-P120ZKMU-A		PQHY-P120ZKMU-A	PQHY-P96ZKMU-A
Model		PQHY-P120ZKMU-A		PQHY-P120ZKMU-A	PQHY-P96ZKMU-A
Minimum Circuit Ampacity	A	13		13	12
Maximum Overcurrent Protection	A	22		22	20
Circulating water	Water flow rate	G/h	1,522 + 1,522 + 1,522		
		G/min (gpm)	25.4 + 25.4 + 25.4		
		m ³ /h	5.76 + 5.76 + 5.76		
		L/min	96 + 96 + 96		
		cfm	3.4 + 3.4 + 3.4		
	Pressure drop	psi	3.48	3.48	3.48
		kPa	24	24	24
	Operating volume range	G/h	1,189 + 1,189 + 1,189 ~ 1,902 + 1,902 + 1,902		
G/min (gpm)		19.8 + 19.8 + 19.8 ~ 31.7 + 31.7 + 31.7			
m ³ /h		4.5 + 4.5 + 4.5 ~ 7.2 + 7.2 + 7.2			
Compressor	Type x Quantity	Inverter scroll hermetic compressor x 1		Inverter scroll hermetic compressor x 1	Inverter scroll hermetic compressor x 1
	Manufacture	AC&R Works, MITSUBISHI ELECTRIC CORPORATION		AC&R Works, MITSUBISHI ELECTRIC CORPORATION	AC&R Works, MITSUBISHI ELECTRIC CORPORATION
	Starting method	Inverter		Inverter	Inverter
	Motor output	kW 7.7		7.7	6.0
	Case heater	kW -		-	-
	Lubricant	MEL32		MEL32	MEL32
External finish		Galvanized steel sheets		Galvanized steel sheets	Galvanized steel sheets
External dimension H x W x D	in.	43-5/16 x 34-11/16 x 21-11/16		43-5/16 x 34-11/16 x 21-11/16	43-5/16 x 34-11/16 x 21-11/16
	mm	1,100 x 880 x 550		1,100 x 880 x 550	1,100 x 880 x 550
Protection devices	High pressure protection	High pressure sensor, High pressure switch at 4.15 MPa (601 psi)		High pressure sensor, High pressure switch at 4.15 MPa (601 psi)	High pressure sensor, High pressure switch at 4.15 MPa (601 psi)
	Inverter circuit	Over-heat protection, Over-current protection		Over-heat protection, Over-current protection	Over-heat protection, Over-current protection
	Compressor	Over-heat protection		Over-heat protection	Over-heat protection
Refrigerant	Type x original charge	R410A x 11 lbs + 1 oz (5.0 kg)		R410A x 11 lbs + 1 oz (5.0 kg)	R410A x 11 lbs + 1 oz (5.0 kg)
	Control	LEV and HIC circuit			
Net weight	lbs (kg)	408 (185)		408 (185)	408 (185)
Heat exchanger	Water volume in plate	G	plate type 1.32		plate type 1.32
		l	5.0		5.0
	Water pressure Max.	psi	290		290
		MPa	2.0		2.0
HIC circuit (HIC: Heat Inter-Changer)		Copper pipe, tube-in-tube structure		Copper pipe, tube-in-tube structure	Copper pipe, tube-in-tube structure
Pipe between unit and distributor	Liquid pipe	in. (mm) 1/2 (12.7) Brazed		1/2 (12.7) Brazed	1/2 (12.7) Brazed
	Gas pipe	in. (mm) 7/8 (22.2) Brazed		7/8 (22.2) Brazed	7/8 (22.2) Brazed
Drawing	External	KJ94G488			
	Wiring	KE94C823		KE94C823	KE94C823
Standard attachment	Document	-			
	Accessory	-			
Optional parts		Details refer to External Drw Heat Source Twinning kit: CMY-Y300CBK2 joint: CMY-Y102SS-G2, CMY-Y102LS-G2, CMY-Y202S-G2, CMY-Y302S-G2 Header: CMY-Y104/108/1010C-G			
Remarks		Details on foundation work, duct work, insulation work, electrical wiring, power source switch, and other items shall be referred to the Installation Manual. Due to continuing improvement, above specifications may be subject to change without notice. The ambient temperature of the Heat Source Unit needs to be kept below 104°F.D.B. (40°C.D.B.) The ambient relative humidity of the Heat Source Unit needs to be kept below 80%. The Heat Source Unit should not be installed at outdoor. Be sure to mount a strainer (more than 50 meshes) at the water inlet piping of the unit. Be sure to provide interlocking for the unit operation and water circuit. Install the supplied insulation material to the unused drain-socket. When installing insulation material around both water and refrigerant piping, follow the installation manual.			

Notes:	Unit converter
1.Nominal cooling conditions (Test conditions are based on AHRI 1230) Indoor: 81°F.D.B./66°F.W.B. (27°C.D.B./19°C.W.B.), Water temperature: 86°F (30°C)	BTU/h =kW x 3.412
2.Nominal heating conditions (Test conditions are based on AHRI 1230) Indoor: 68°F.D.B. (20°C.D.B.), Water temperature: 68°F (20°C)	cfm =m ³ /min x 35.31
	lbs =kg/0.4536
	*Above specification data is subject to rounding variation.

1. SPECIFICATIONS

Heat Source Model			PQHY-P360ZSKMU-A	
Indoor Model			Non-Ducted	
Power source			3-phase 3-wire 575 V ±10% 60 Hz	
Cooling capacity (Nominal)	*1	BTU/h	360,000	
		kW	105.5	
	(575)	Power input	27.35	
		Current input	30.5	
	(Rated)	BTU/h	342,000	
		kW	100.2	
(575)	Power input	26.39	25.45	
	Current input	29.4	28.3	
Temp. range of cooling	Indoor	W.B.	59~75°F (15~24°C)	
	Circulating water	°F	50~113°F (10~45°C)	
Heating capacity (Nominal)	*2	BTU/h	405,000	
		kW	118.7	
	(575)	Power input	25.75	
		Current input	28.7	
	(Rated)	BTU/h	387,000	
		kW	113.4	
(575)	Power input	26.85	23.96	
	Current input	29.9	26.7	
Temp. range of heating	Indoor	D.B.	59~81°F (15~27°C)	
	Circulating water	°F	50~95°F (10~35°C)	
Indoor unit connectable	Total capacity	50~130% of heat source unit capacity		
	Model/Quantity	P06~P96/2~50		
Sound pressure level (measured in anechoic room)	dB <A>	59.0		
Refrigerant piping diameter	Liquid pipe	in. (mm)	3/4 (19.05) Brazed	
	Gas pipe	in. (mm)	1-5/8 (41.28) Brazed	

Set Model			PQHY-P120ZKMU-A	PQHY-P120ZKMU-A	PQHY-P120ZKMU-A
Model			PQHY-P120ZKMU-A	PQHY-P120ZKMU-A	PQHY-P120ZKMU-A
Minimum Circuit Ampacity			13	13	13
Maximum Overcurrent Protection			22	22	22
Circulating water	Water flow rate	G/h	1,522 + 1,522 + 1,522		
		G/min (gpm)	25.4 + 25.4 + 25.4		
		m ³ /h	5.76 + 5.76 + 5.76		
		L/min	96 + 96 + 96		
		cfm	3.4 + 3.4 + 3.4		
	Pressure drop	psi	3.48	3.48	3.48
kPa		24	24	24	
Operating volume range	G/h	1,189 + 1,189 + 1,189 ~ 1,902 + 1,902 + 1,902			
	G/min (gpm)	19.8 + 19.8 + 19.8 ~ 31.7 + 31.7 + 31.7			
	m ³ /h	4.5 + 4.5 + 4.5 ~ 7.2 + 7.2 + 7.2			
Compressor	Type x Quantity		Inverter scroll hermetic compressor x 1	Inverter scroll hermetic compressor x 1	Inverter scroll hermetic compressor x 1
	Manufacture		AC&R Works, MITSUBISHI ELECTRIC CORPORATION	AC&R Works, MITSUBISHI ELECTRIC CORPORATION	AC&R Works, MITSUBISHI ELECTRIC CORPORATION
	Starting method		Inverter	Inverter	Inverter
	Motor output	kW	7.7	7.7	7.7
	Case heater	kW	-	-	-
	Lubricant		MEL32	MEL32	MEL32
External finish			Galvanized steel sheets	Galvanized steel sheets	Galvanized steel sheets
External dimension H x W x D			in.	43-5/16 x 34-11/16 x 21-11/16	43-5/16 x 34-11/16 x 21-11/16
			mm	1,100 x 880 x 550	1,100 x 880 x 550
Protection devices	High pressure protection		High pressure sensor, High pressure switch at 4.15 MPa (601 psi)	High pressure sensor, High pressure switch at 4.15 MPa (601 psi)	High pressure sensor, High pressure switch at 4.15 MPa (601 psi)
	Inverter circuit		Over-heat protection, Over-current protection	Over-heat protection, Over-current protection	Over-heat protection, Over-current protection
	Compressor		Over-heat protection	Over-heat protection	Over-heat protection
Refrigerant	Type x original charge		R410A x 11 lbs + 1 oz (5.0 kg)	R410A x 11 lbs + 1 oz (5.0 kg)	R410A x 11 lbs + 1 oz (5.0 kg)
	Control		LEV and HIC circuit		
Net weight			408 (185)	408 (185)	408 (185)
Heat exchanger	Water volume in plate		plate type	plate type	plate type
			G	1.32	1.32
	Water pressure Max.		l	5.0	5.0
			psi	290	290
		MPa	2.0	2.0	
HIC circuit (HIC: Heat Inter-Changer)			Copper pipe, tube-in-tube structure	Copper pipe, tube-in-tube structure	Copper pipe, tube-in-tube structure
Pipe between unit and distributor	Liquid pipe	in. (mm)	1/2 (12.7) Brazed	1/2 (12.7) Brazed	1/2 (12.7) Brazed
	Gas pipe	in. (mm)	7/8 (22.2) Brazed	7/8 (22.2) Brazed	7/8 (22.2) Brazed
Drawing	External		KJ94G488		
	Wiring		KE94C823	KE94C823	KE94C823
Standard attachment	Document		-		
	Accessory		Details refer to External Drw		
Optional parts			Heat Source Twinning kit: CMY-Y300CBK2 joint: CMY-Y102SS-G2, CMY-Y102LS-G2, CMY-Y202S-G2, CMY-Y302S-G2 Header: CMY-Y104/108/1010C-G		
Remarks			<p>Details on foundation work, duct work, insulation work, electrical wiring, power source switch, and other items shall be referred to the Installation Manual.</p> <p>Due to continuing improvement, above specifications may be subject to change without notice.</p> <p>The ambient temperature of the Heat Source Unit needs to be kept below 104°F D.B. (40°C D.B.)</p> <p>The ambient relative humidity of the Heat Source Unit needs to be kept below 80%.</p> <p>The Heat Source Unit should not be installed at outdoor.</p> <p>Be sure to mount a strainer (more than 50 meshes) at the water inlet piping of the unit.</p> <p>Be sure to provide interlocking for the unit operation and water circuit.</p> <p>Install the supplied insulation material to the unused drain-socket.</p> <p>When installing insulation material around both water and refrigerant piping, follow the installation manual.</p>		

Notes:	Unit converter
1.Nominal cooling conditions (Test conditions are based on AHRI 1230) Indoor: 81°F D.B./66°F W.B. (27°C D.B./19°C W.B.), Water temperature: 86°F (30°C)	BTU/h =kW x 3.412
2.Nominal heating conditions (Test conditions are based on AHRI 1230) Indoor: 68°F D.B. (20°C D.B.), Water temperature: 68°F (20°C)	cfm =m ³ /min x 35.31
	lbs =kg/0.4536
	*Above specification data is subject to rounding variation.

PQHY-P72, 96, 120ZKMU-A

Unit : mm(in)

<Accessories>

- Refrigerant (Liquid) conn. pipe 1pc. (P72/P96/P120 ; Packaged in the accessory kit)
- Refrigerant (Gas) conn. pipe 1pc. (P72 ; Packaged in the accessory kit)
- Refrigerant (Gas) conn. elbow 1pc. (P72/P96/P120 ; Packaged in the accessory kit)
- Water stopper(Liquid,Gas) 1pc. each (P72/P96/P120 ; Packaged in the accessory kit)
- Sealing material for water stopper (Liquid,Gas) 1pc. each (P72/P96/P120 ; Packaged in the accessory kit)
- Sealing material for field piping (Liquid,Gas) 1pc. each (P72/P96/P120 ; Packaged in the accessory kit)
- Sealing material for drain socket 1pc. (P72/P96/P120 ; Packaged in the accessory kit)
- Pipe cover for gas 1pc. (P72/P96/P120 ; Packaged in the accessory kit)

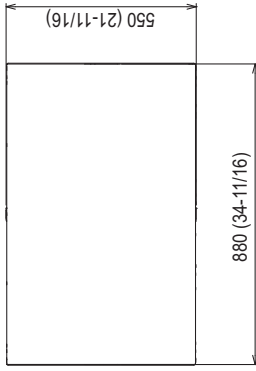

Top view

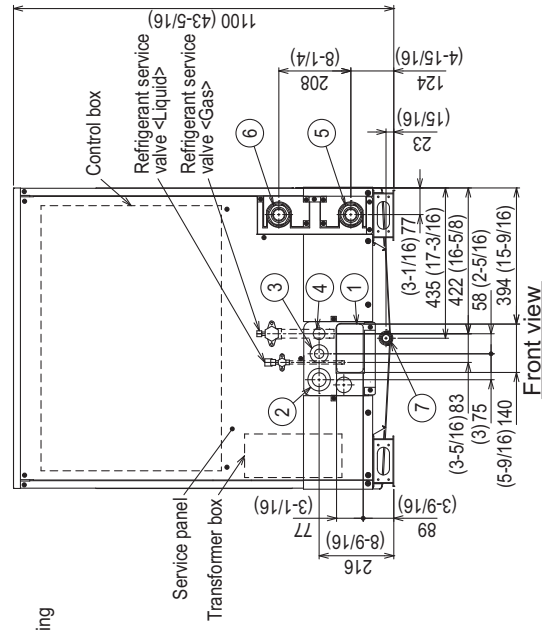

Front view

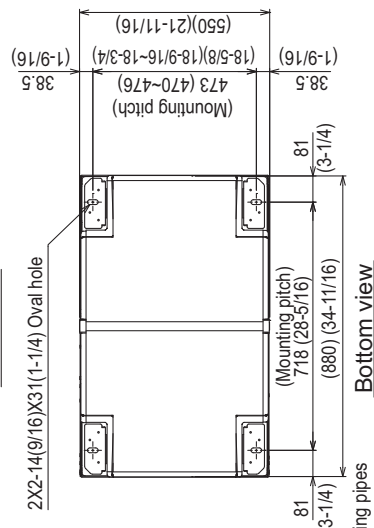

Bottom view

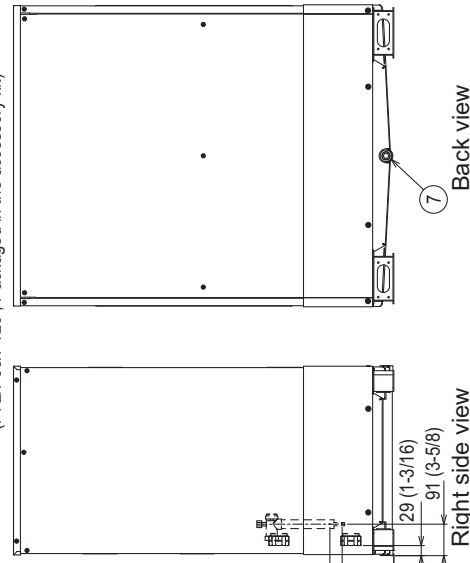

Right side view

NO.	Usage	Specifications
①	For pipes	140 x 77 Knockout hole (5-9/16) (3-1/16)
②	For wires	ø62.7 or ø34.5 Knockout hole (2-1/2) (1-3/8)
③		ø43.7 or ø22.2 Knockout hole (1-3/4) (7/8)
④	For transmission cables	ø34 Knockout hole (1-3/8)
⑤	Water pipe inlet	Rc1-1/2 Screw
⑥	Water pipe outlet	Rc1-1/2 Screw
⑦	Drain pipe	Rc3/4 Screw

- Note1. Close a hole of the water piping, the refrigerant piping, the power supply, and the control wiring and unused knockout holes with the putty etc. so as not to infiltrate rain water etc. (field erection work)
- Note2. At the time of product shipment, the front side piping specification serves as the local drainage connection. When connecting on the rear side, please remove the rear side plug sealing corks, and attach a front side. Ensure there is no leak after the attachment has been fitted.
- Note3. Take notice of service space as Fig.A. (In case of single installation, 600mm(23-5/8) or more of back space as front space makes easier access when servicing the unit from rear side.)
- Note4. If water pipes or refrigerant pipes stretch upward, required space for service and maintenance due to replacement of control box is shown in Fig.B.
- Note5. Environmental condition for installation: -20~40°C(DB)(-4~104°F) as indoor installation.
- Note6. In case the temperature around the heat source unit has possibility to drop under 0°C(32°F), be careful for the following point to prevent the pipe burst by the water pipe freeze-up.
 · Circulate the water all the time even if the heat source unit is not in operation.
 · Drain the water from inside of the heat source unit when the heat source unit will not operate for a long term.
- Note7. Ensure that the drain piping is downward with a pitch of more than 1/100.
- Note8. At brazing of pipes, wrap the refrigerant service valve with wet cloth and keep the temperature of refrigerant service valve under 120°C(248°F).

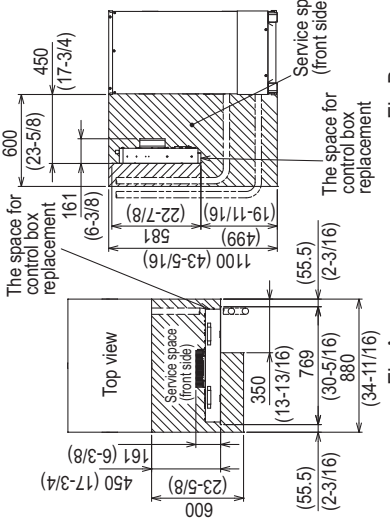

Fig.A

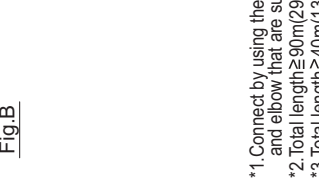

Fig.B

Connecting pipe specifications

Model	Connection specifications for the refrigerant service valve	
	Liquid	Gas
PQHY-P72ZKMU-A	ø9.52 Brazed ^{*1} (3/8)	ø19.05 Brazed ^{*1} (3/4)
PQHY-P96ZKMU-A	ø9.52 Brazed ^{*1} (3/8)	ø22.2 Brazed ^{*1} (7/8)
PQHY-P120ZKMU-A	ø9.52 Brazed ^{*1} (3/8)	ø12.7 Brazed ^{*2} (1/2)

- *1. Connect by using the connecting pipes and elbow that are supplied.
- *2. Total length ≥ 90m(295ft)
- *3. Total length ≥ 40m(131ft)

PQHY-P144, 168, 192, 216, 240ZSKMU-A

Unit : mm(in)

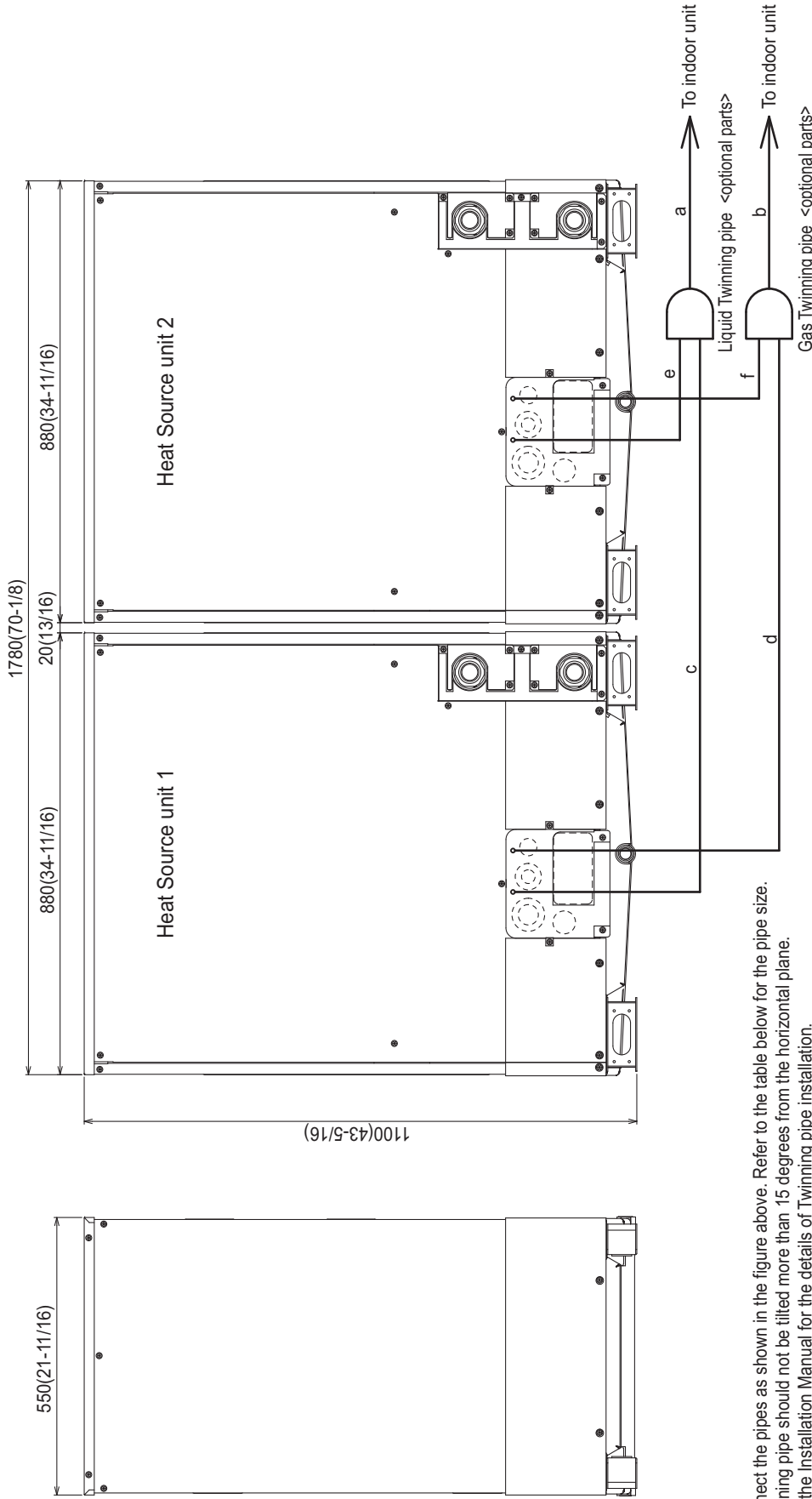

- Note 1. Connect the pipes as shown in the figure above. Refer to the table below for the pipe size.
 2. Twinning pipe should not be tilted more than 15 degrees from the horizontal plane.
 3. See the Installation Manual for the details of Twinning pipe installation.
 4. The pipe section before the Twinning pipe (sections "a" and "b" in the figure) must have at least 500mm(19-11/16) of straight section (*including the straight pipe that is supplied with the Twinning pipe).
 5. Only use the Twinning pipe by Mitsubishi (optional parts).

Twinning pipe connection size

Package unit name	PQHY-P144ZSKMU-A	PQHY-P168ZSKMU-A	PQHY-P192ZSKMU-A	PQHY-P216ZSKMU-A	PQHY-P240ZSKMU-A
Heat Source unit 1	PQHY-P72ZKMU-A	PQHY-P96ZKMU-A	PQHY-P120ZKMU-A	PQHY-P144ZKMU-A	PQHY-P168ZKMU-A
Heat Source unit 2	PQHY-P72ZKMU-A	PQHY-P96ZKMU-A	PQHY-P120ZKMU-A	PQHY-P144ZKMU-A	PQHY-P168ZKMU-A
Twinning pipe Kit(optional parts)	CMY-Y100CBK3				
Indoor unit~Twinning pipe	Liquid a	ø12.7(1/2)		ø15.88(5/8)	
	Gas b			ø28.58(1-1/8)	
Twinning pipe~Heat Source unit 1	Liquid c	ø9.52(3/8)			ø12.7(1/2)
	Gas d	ø19.05(3/4)		ø22.2(7/8)	
Twinning pipe~Heat Source unit 2	Liquid e	ø9.52(3/8)			ø12.7(1/2)
	Gas f	ø19.05(3/4)		ø22.2(7/8)	

PQHY-P264,288,312,336,360ZSKMU-A

Unit : mm(in)

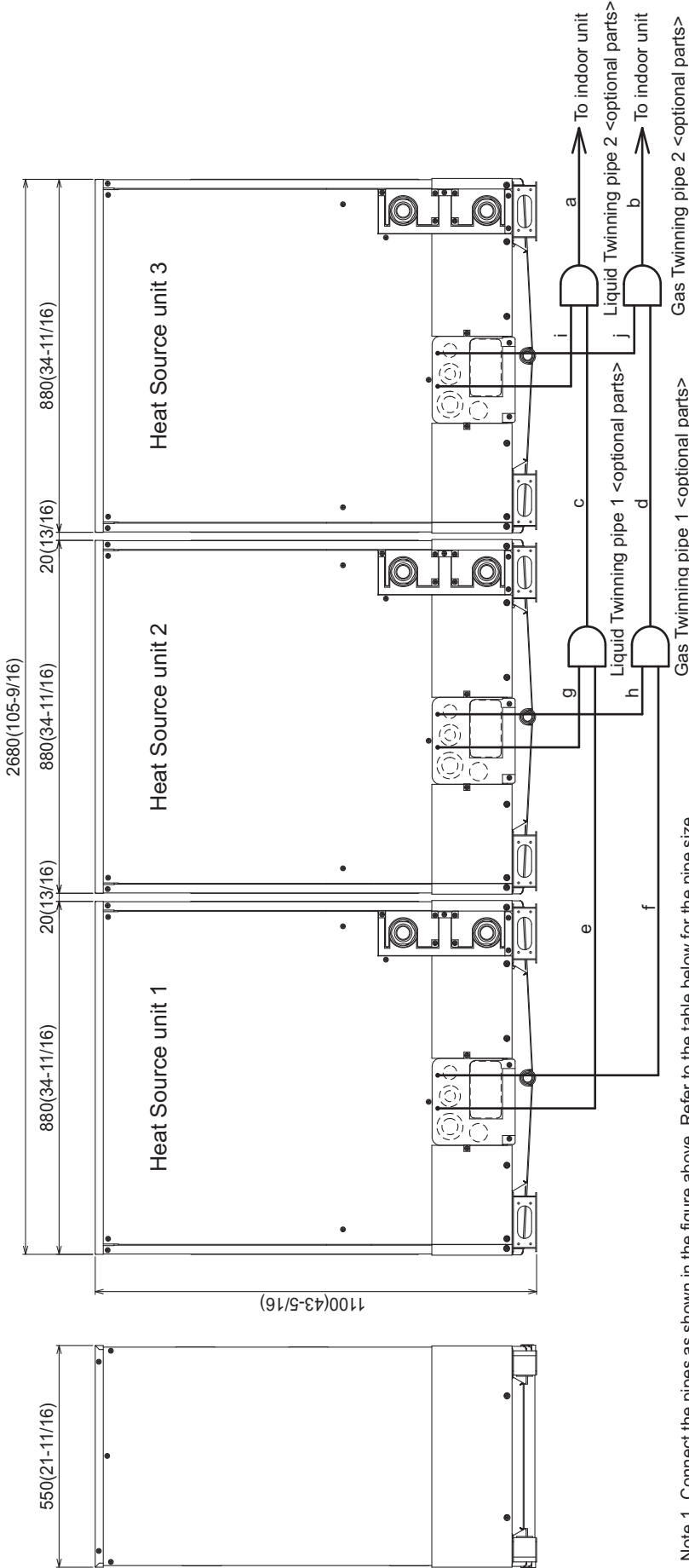

- Note 1. Connect the pipes as shown in the figure above. Refer to the table below for the pipe size.
 2. Twinning pipe should not be tilted more than 15 degrees from the horizontal plane.
 3. See the Installation Manual for the details of Twinning pipe installation.
 4. The pipe section before the Twinning pipe (sections "a", "b", "c" and "d" in the figure) must have at least 500mm(19-11/16) of straight section (*including the straight pipe that is supplied with the Twinning pipe).
 5. Only use the Twinning pipe by Mitsubishi (optional parts).

Twinning pipe connection size

Package unit name	PQHY-P264ZSKMU-A	PQHY-P288ZSKMU-A	PQHY-P312ZSKMU-A	PQHY-P336ZSKMU-A	PQHY-P360ZSKMU-A
Heat Source unit 1	PQHY-P96ZKMU-A	PQHY-P96ZKMU-A	PQHY-P120ZKMU-A	PQHY-P120ZKMU-A	PQHY-P120ZKMU-A
Heat Source unit 2	PQHY-P96ZKMU-A	PQHY-P96ZKMU-A	PQHY-P96ZKMU-A	PQHY-P96ZKMU-A	PQHY-P120ZKMU-A
Heat Source unit 3	PQHY-P72ZKMU-A	PQHY-P96ZKMU-A	PQHY-P96ZKMU-A	PQHY-P96ZKMU-A	PQHY-P120ZKMU-A
Twinning pipe Kit(optional parts)	CMY-Y300CBK2				
Indoor unit~ Twinning pipe 2	ø19.05(3/4)				
Twinning pipe 1~Twinning pipe 2	Liquid	ø34.93(1-3/8)			
	Gas	ø19.05(3/4)			
Twinning pipe 1~Heat Source unit 1	Liquid	ø34.93(1-3/8)			
	Gas	ø9.52(3/8)			
Twinning pipe 1~Heat Source unit 2	Liquid	ø9.52(3/8)			
	Gas	ø22.2(7/8)			
Twinning pipe 2~Heat Source unit 3	Liquid	ø9.52(3/8)			
	Gas	ø22.2(7/8)			

PQHY-P72, 96, 120ZKMU-A

Unit : mm[in.]

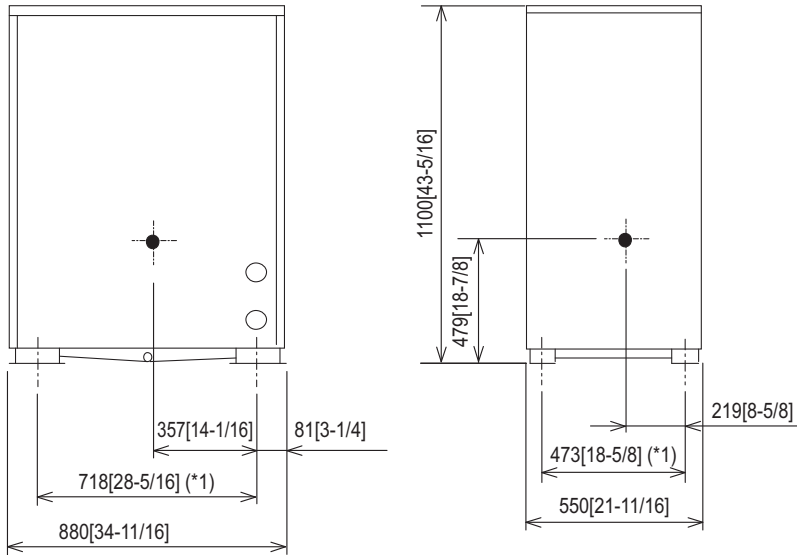

*1 Mounting Pitch

PQHY-P72, 96, 120ZKMU-A

- *1. Single-dotted lines indicate wiring not supplied with the unit.
- *2. Dotted lines indicate the control box boundaries.
- *3. Refer to the Data book for connecting input/output signal connectors.
- *4. Daisy-chain terminals (TB3) on the heat source units in the same refrigerant system together.
- *5. Faston terminals have a locking function. Make sure the terminals are securely locked in place after insertion. Press the tab on the terminals to remove them.
- *6. Control box houses high-voltage parts. Before inspecting the inside of the control box, turn off the power, keep the tab off for at least 10 minutes, and confirm that the voltage between FT-P and FT-N on INV Board has dropped to DC20V or less.
- *7. Refer to the Data book for wiring terminal block for Pump Interlock and Operation ON signal.

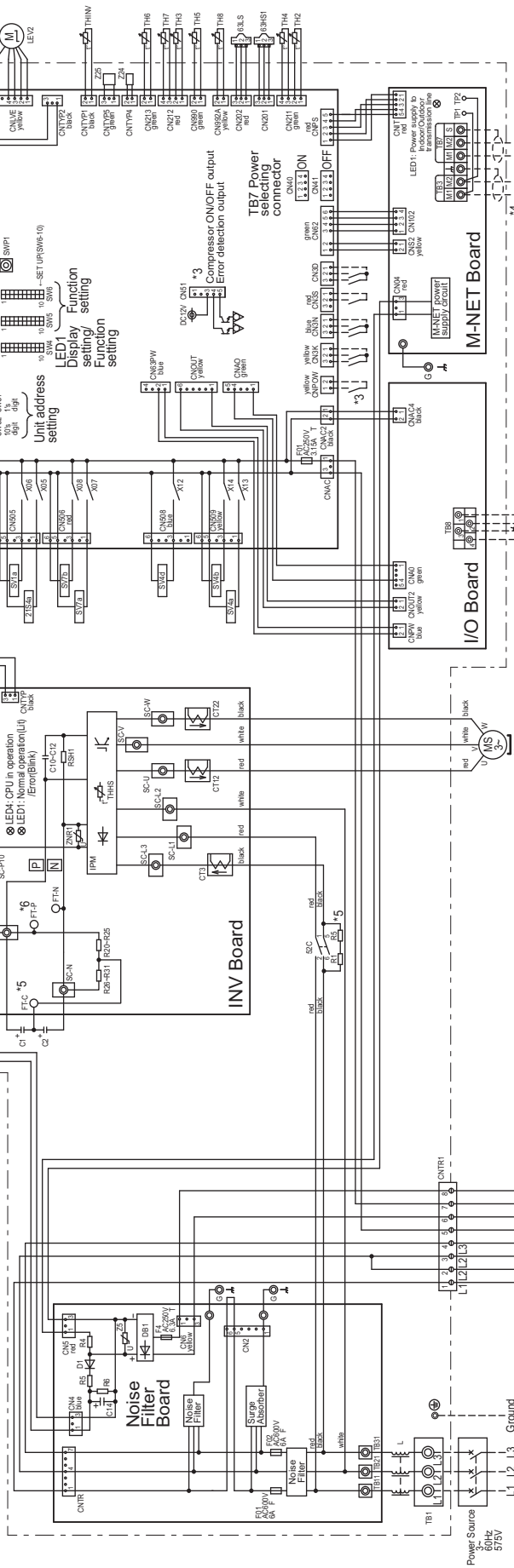

<Symbol explanation>

Symbol	Explanation	Symbol	Explanation
Z1S4a	4-way valve	SV4a,b,d	Solenoid valve
63H1	High pressure protection for the heat source unit	SV7a,b	Solenoid valve
63H5L	High pressure	TB1	Terminal block
63LS	High pressure	TB3	Terminal block
63LS	Magnetic contact (inverter main circuit)	TB7	Terminal block
C1.2	Capacitor (inverter main circuit)	TB8	Terminal block
C1.2,2.3	Current sensor (AC)		
DCL	DC reactor	TH2	Thermistor
L	Choke coil (for high frequency noise reduction)	TH3	Thermistor
LEV1	HIC bypass. Controls refrigerant flow in HIC circuit	TH4	Thermistor
LEV2	Pressure control. Refrigerant flow rate control	TH5	Thermistor
LEV6	Pressure control. Refrigerant flow rate control	TH6	Thermistor
LEV6	Heat exchanger capacity control	TH7	Thermistor
ME7	Heat exchanger capacity control	TH8	Thermistor
RL5	Fan motor (radiator panel)	TH9	Thermistor
RSH1	Resistor	THINV	Thermistor
SV1a	Solenoid valve	THHS	Thermistor
		Z24,25	Function setting connector

Transformer box

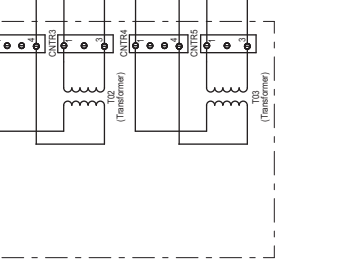

WY 575V

Measurement condition
PQHY-P72,96,120ZKMU-A

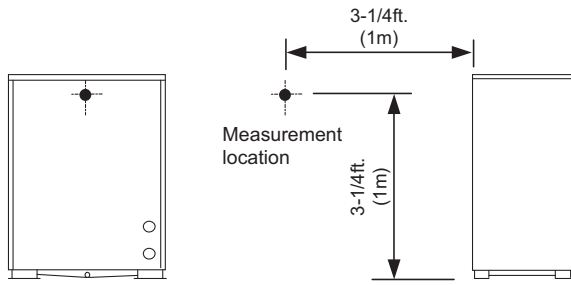

Sound level of PQHY-P120ZKMU-A

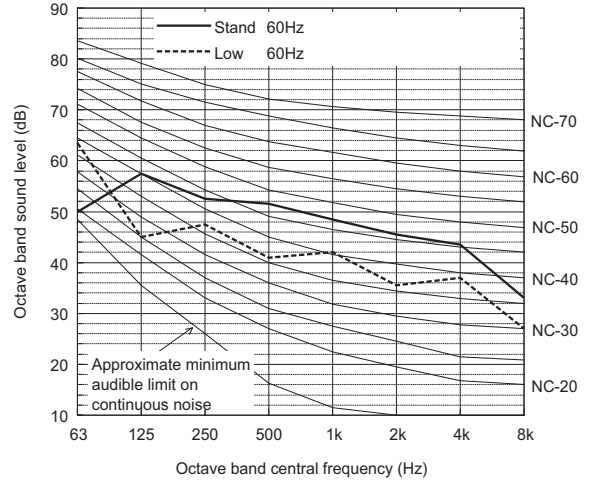

		63	125	250	500	1k	2k	4k	8k	dB(A)
Standard	60Hz	50.0	57.5	52.5	51.5	48.5	45.5	43.5	33.0	54.0
Low noise mode	60Hz	63.5	45.0	47.5	41.0	42.0	35.5	37.0	27.0	47.0

When Low noise mode is set, the A/C system's capacity is limited. The system could return to normal operation from Low noise mode automatically in the case that the operation condition is severe.

Sound level of PQHY-P72ZKMU-A

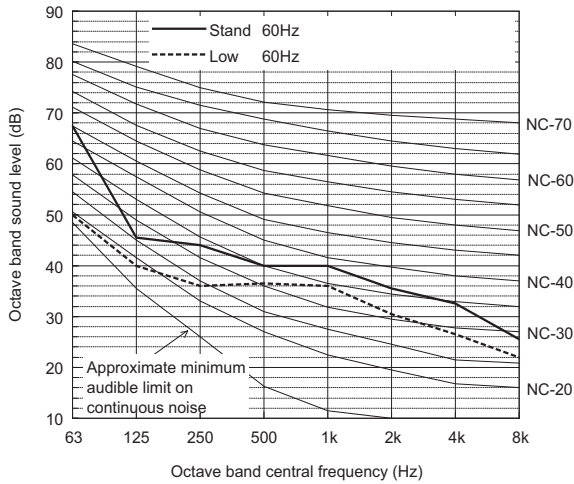

		63	125	250	500	1k	2k	4k	8k	dB(A)
Standard	60Hz	67.5	45.5	44.0	40.0	40.0	35.5	32.5	25.5	46.0
Low noise mode	60Hz	50.0	40.0	36.0	36.5	36.0	30.5	26.5	22.0	40.0

When Low noise mode is set, the A/C system's capacity is limited. The system could return to normal operation from Low noise mode automatically in the case that the operation condition is severe.

Sound level of PQHY-P96ZKMU-A

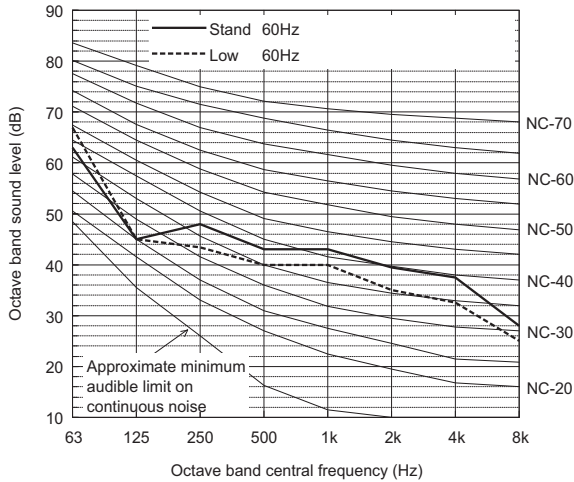

		63	125	250	500	1k	2k	4k	8k	dB(A)
Standard	60Hz	63.0	45.0	48.0	43.0	43.0	39.5	37.5	28.0	48.0
Low noise mode	60Hz	67.0	45.0	43.5	40.0	40.0	35.0	32.5	25.0	46.0

When Low noise mode is set, the A/C system's capacity is limited. The system could return to normal operation from Low noise mode automatically in the case that the operation condition is severe.

Measurement condition
PQHY-P144,168,192,216,240ZSKMU-A

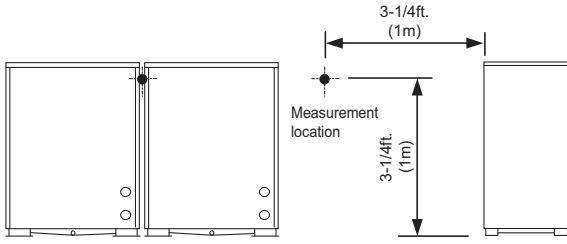

Sound level of PQHY-P192ZSKMU-A

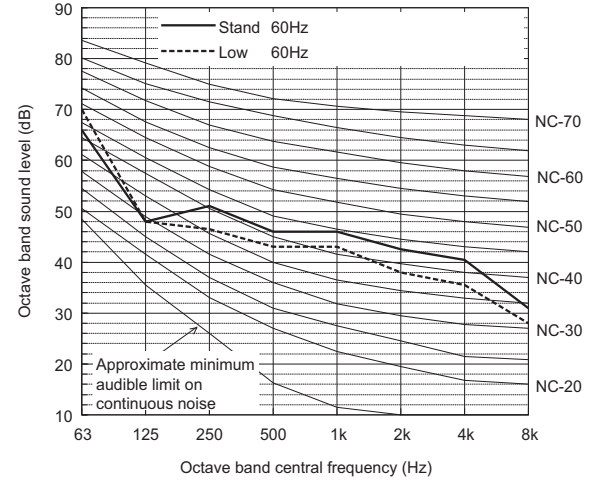

		63	125	250	500	1k	2k	4k	8k	dB(A)
Standard	60Hz	66.0	48.0	51.0	46.0	46.0	42.5	40.5	31.0	51.0
Low noise mode	60Hz	70.0	48.0	46.5	43.0	43.0	38.0	35.5	28.0	49.0

When Low noise mode is set, the A/C system's capacity is limited. The system could return to normal operation from Low noise mode automatically in the case that the operation condition is severe.

Sound level of PQHY-P144ZSKMU-A

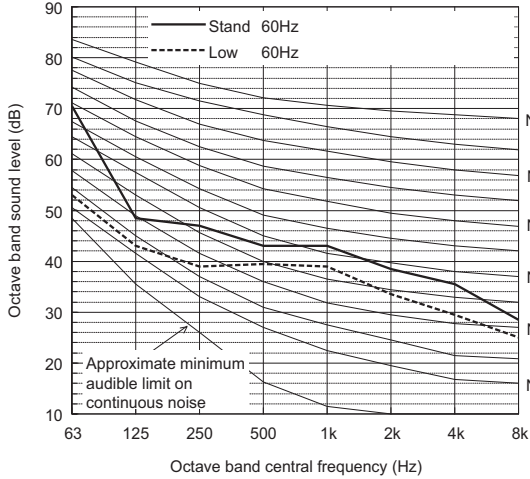

		63	125	250	500	1k	2k	4k	8k	dB(A)
Standard	60Hz	70.5	48.5	47.0	43.0	43.0	38.5	35.5	28.5	49.0
Low noise mode	60Hz	53.0	43.0	39.0	39.5	39.0	33.5	29.5	25.0	43.0

When Low noise mode is set, the A/C system's capacity is limited. The system could return to normal operation from Low noise mode automatically in the case that the operation condition is severe.

Sound level of PQHY-P216ZSKMU-A

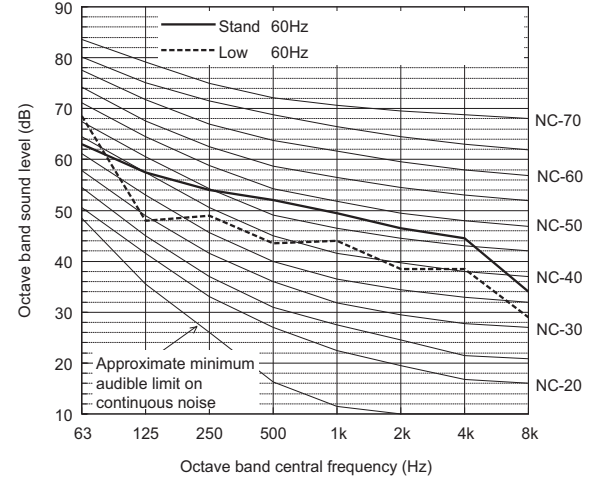

		63	125	250	500	1k	2k	4k	8k	dB(A)
Standard	60Hz	63.0	57.5	54.0	52.0	49.5	46.5	44.5	34.0	55.0
Low noise mode	60Hz	68.5	48.0	49.0	43.5	44.0	38.5	38.5	29.0	49.5

When Low noise mode is set, the A/C system's capacity is limited. The system could return to normal operation from Low noise mode automatically in the case that the operation condition is severe.

Sound level of PQHY-P168ZSKMU-A

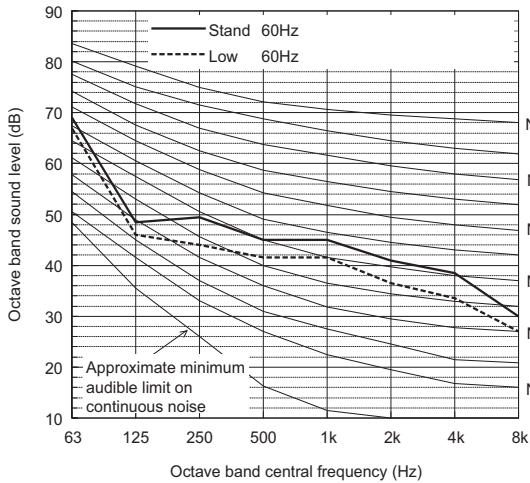

		63	125	250	500	1k	2k	4k	8k	dB(A)
Standard	60Hz	69.0	48.5	49.5	45.0	45.0	41.0	38.5	30.0	50.0
Low noise mode	60Hz	67.0	46.0	44.0	41.5	41.5	36.5	33.5	27.0	47.0

When Low noise mode is set, the A/C system's capacity is limited. The system could return to normal operation from Low noise mode automatically in the case that the operation condition is severe.

Sound level of PQHY-P240ZSKMU-A

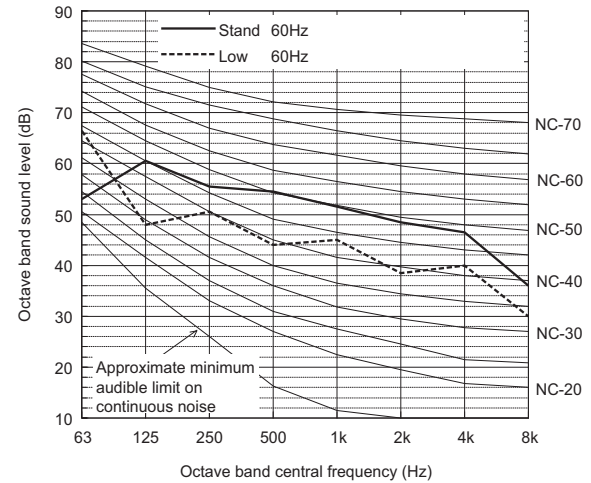

		63	125	250	500	1k	2k	4k	8k	dB(A)
Standard	60Hz	53.0	60.5	55.5	54.5	51.5	48.5	46.5	36.0	57.0
Low noise mode	60Hz	66.5	48.0	50.5	44.0	45.0	38.5	40.0	30.0	50.0

When Low noise mode is set, the A/C system's capacity is limited. The system could return to normal operation from Low noise mode automatically in the case that the operation condition is severe.

Measurement condition
PQHY-P264,288,312,336,360ZSKMU-A

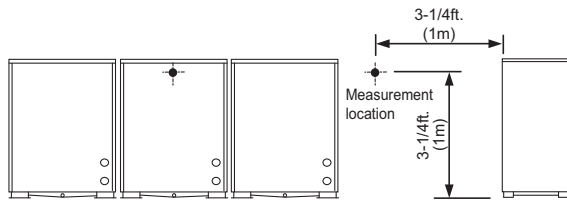

Sound level of PQHY-P312ZSKMU-A

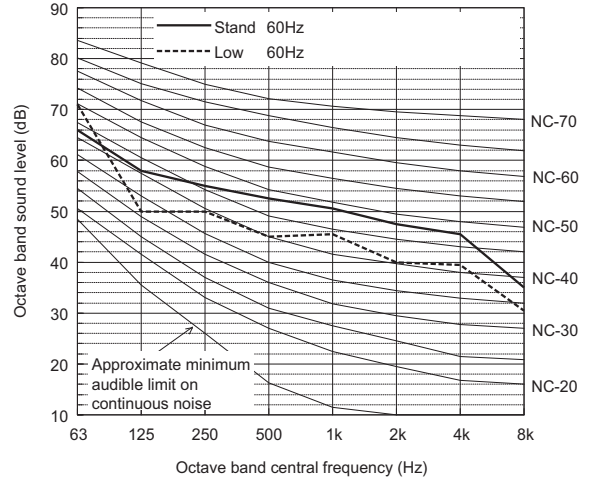

		63	125	250	500	1k	2k	4k	8k	dB(A)
Standard	60Hz	66.0	58.0	55.0	52.5	50.5	47.5	45.5	35.0	56.0
Low noise mode	60Hz	71.0	50.0	50.0	45.0	45.5	40.0	39.5	30.5	51.0

When Low noise mode is set, the A/C system's capacity is limited. The system could return to normal operation from Low noise mode automatically in the case that the operation condition is severe.

Sound level of PQHY-P264ZSKMU-A

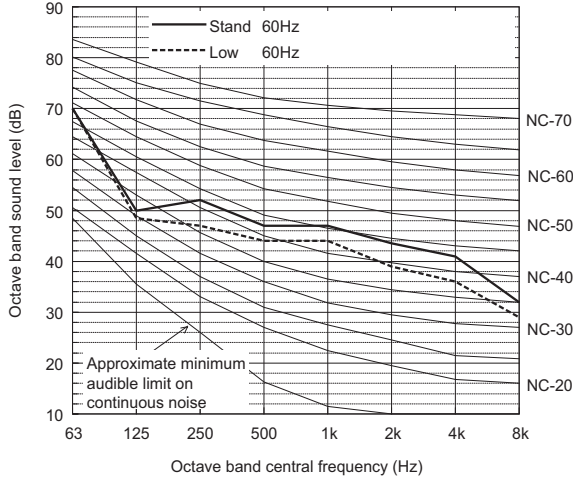

		63	125	250	500	1k	2k	4k	8k	dB(A)
Standard	60Hz	70.0	50.0	52.0	47.0	47.0	43.5	41.0	32.0	52.0
Low noise mode	60Hz	70.0	48.5	47.0	44.0	44.0	39.0	36.0	29.0	49.5

When Low noise mode is set, the A/C system's capacity is limited. The system could return to normal operation from Low noise mode automatically in the case that the operation condition is severe.

Sound level of PQHY-P336ZSKMU-A

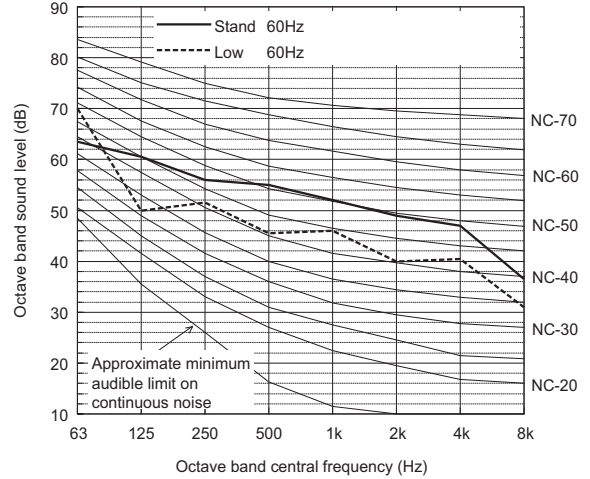

		63	125	250	500	1k	2k	4k	8k	dB(A)
Standard	60Hz	63.5	60.5	56.0	55.0	52.0	49.0	47.0	36.5	57.5
Low noise mode	60Hz	70.0	50.0	51.5	45.5	46.0	40.0	40.5	31.0	51.5

When Low noise mode is set, the A/C system's capacity is limited. The system could return to normal operation from Low noise mode automatically in the case that the operation condition is severe.

Sound level of PQHY-P288ZSKMU-A

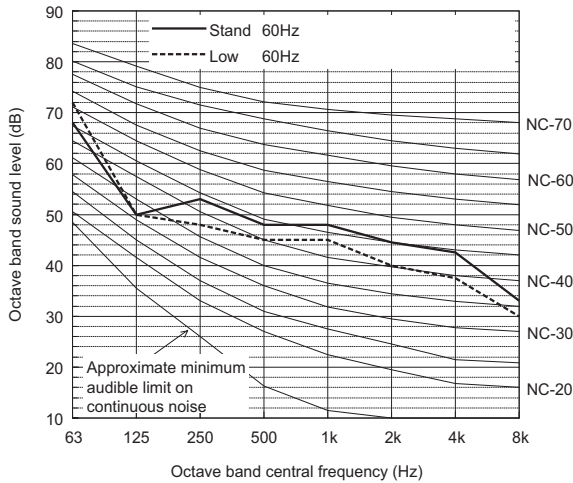

		63	125	250	500	1k	2k	4k	8k	dB(A)
Standard	60Hz	68.0	50.0	53.0	48.0	48.0	44.5	42.5	33.0	53.0
Low noise mode	60Hz	72.0	50.0	48.0	45.0	45.0	40.0	37.5	30.0	51.0

When Low noise mode is set, the A/C system's capacity is limited. The system could return to normal operation from Low noise mode automatically in the case that the operation condition is severe.

Sound level of PQHY-P360ZSKMU-A

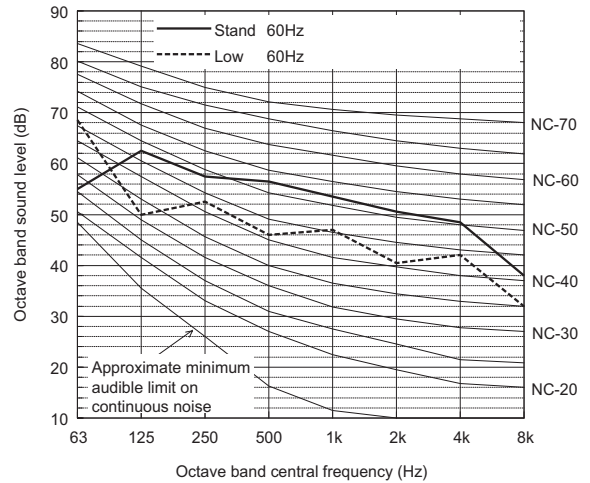

		63	125	250	500	1k	2k	4k	8k	dB(A)
Standard	60Hz	55.0	62.5	57.5	56.5	53.5	50.5	48.5	38.0	59.0
Low noise mode	60Hz	68.5	50.0	52.5	46.0	47.0	40.5	42.0	32.0	52.0

When Low noise mode is set, the A/C system's capacity is limited. The system could return to normal operation from Low noise mode automatically in the case that the operation condition is severe.

WY 575V

6-1. Correction by temperature

CITY MULTI could have various capacities at different designing temperatures. Using the nominal cooling/heating capacity values and the ratios below, the capacity can be found for various temperatures.

PQHY-			P72ZKMU		
Nominal Cooling Capacity	kW	21.1	Rated Cooling Capacity	kW	20.2
	BTU/h	72,000		BTU/h	69,000
Input	kW	3.75	Input	kW	(Non-Ducted) 2.96 (Ducted) 3.49

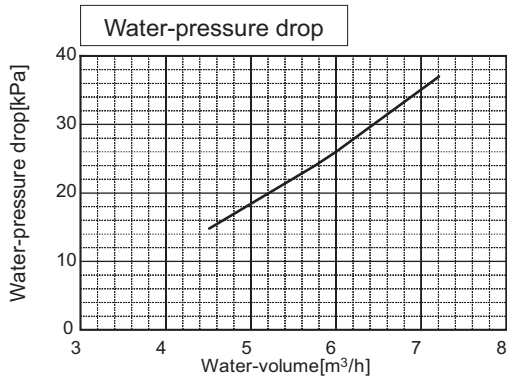
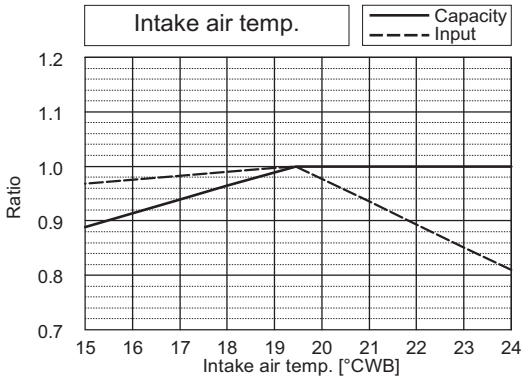
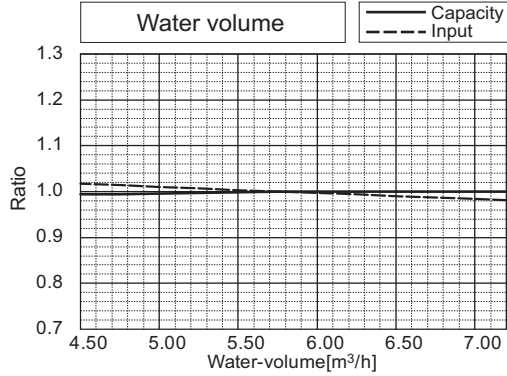
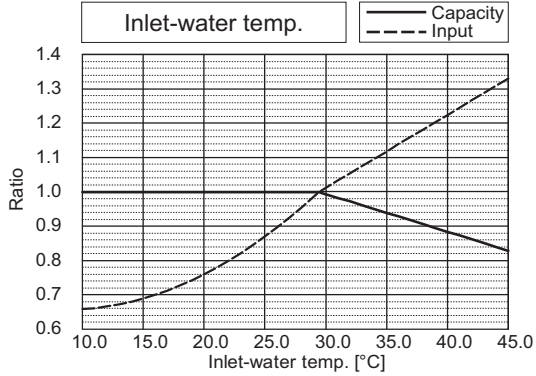

PQHY-			P72ZKMU		
Nominal Heating Capacity	kW	23.4	Rated Heating Capacity	kW	22.3
	BTU/h	80,000		BTU/h	76,000
Input	kW	3.93	Input	kW	(Non-Ducted) 3.48 (Ducted) 3.66

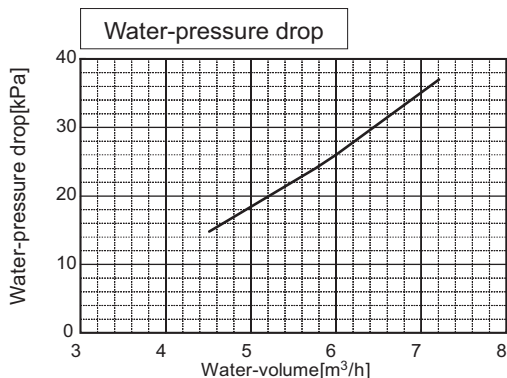
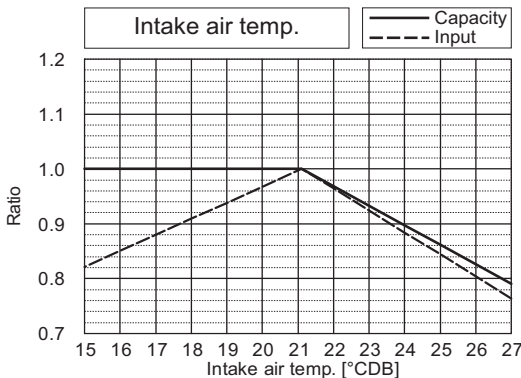
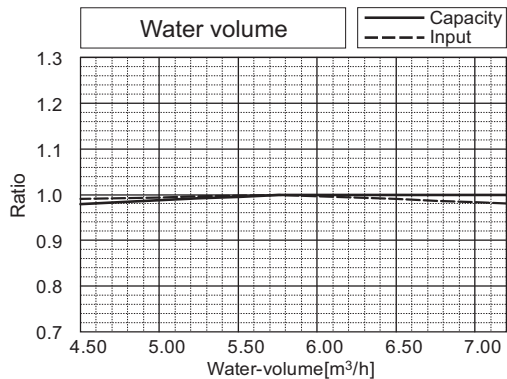
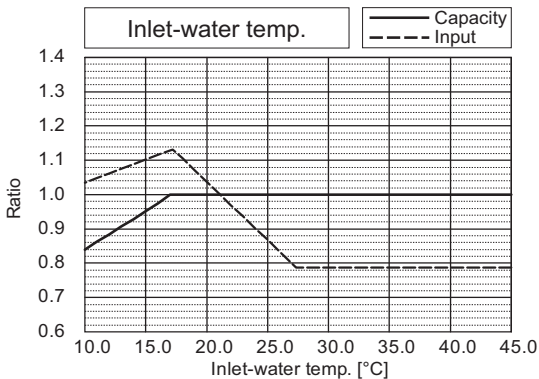

WY 575V

6. CAPACITY TABLES

PQHY-			P96ZKMU		
Nominal Cooling Capacity	kW	28.1	Rated Cooling Capacity	kW	27.0
	BTU/h	96,000		BTU/h	92,000
Input	kW	5.93	Input	kW	(Non-Ducted) 4.26 (Ducted) 5.52

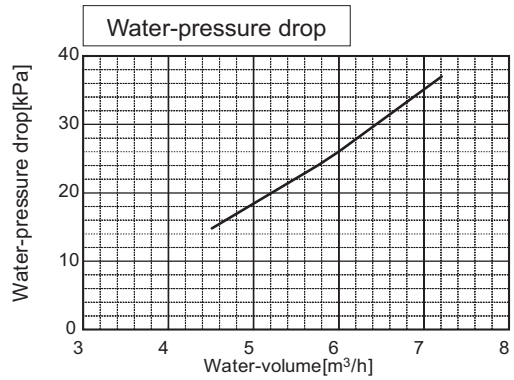
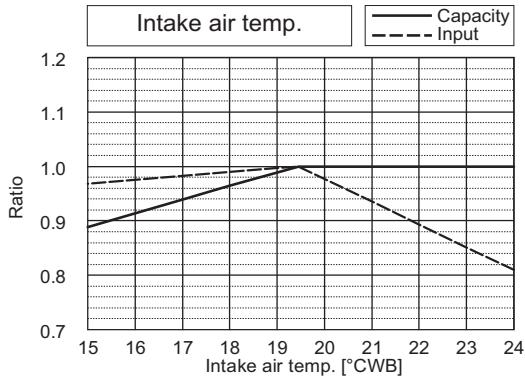
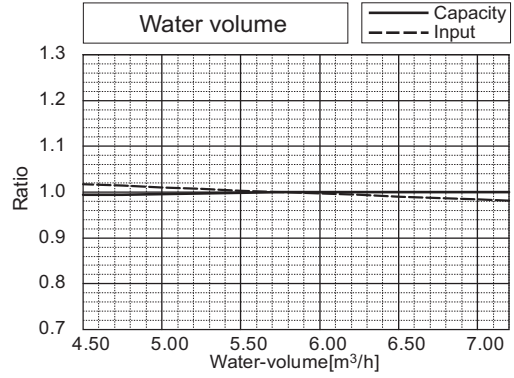
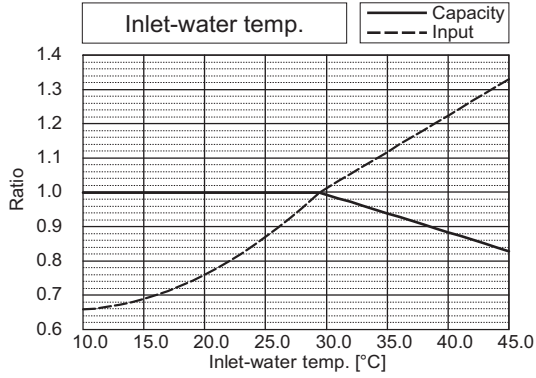

PQHY-			P96ZKMU		
Nominal Heating Capacity	kW	31.7	Rated Heating Capacity	kW	30.2
	BTU/h	108,000		BTU/h	103,000
Input	kW	6.17	Input	kW	(Non-Ducted) 4.87 (Ducted) 5.74

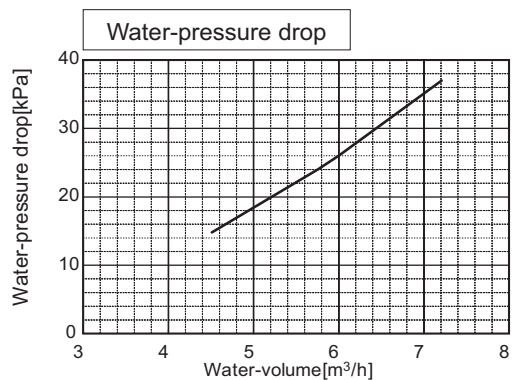
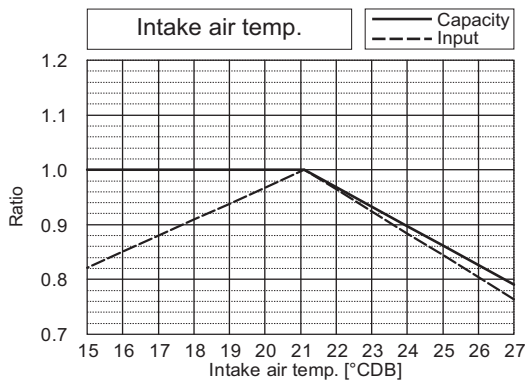
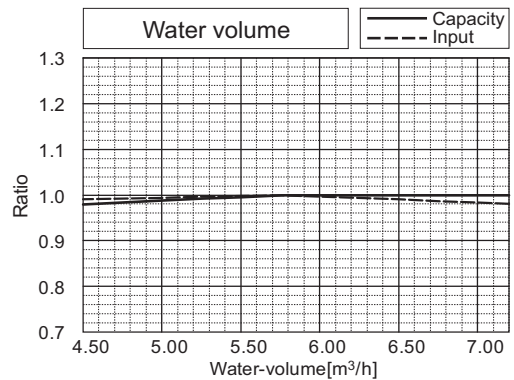
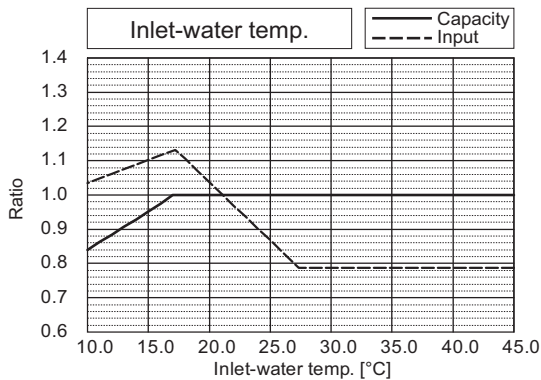

WY 575V

6. CAPACITY TABLES

PQHY-			P120ZKMU		
Nominal Cooling Capacity	kW	35.2	Rated Cooling Capacity	kW	33.4
	BTU/h	120,000		BTU/h	114,000
Input	kW	7.90	Input	kW	(Non-Ducted) 6.72 (Ducted) 7.35

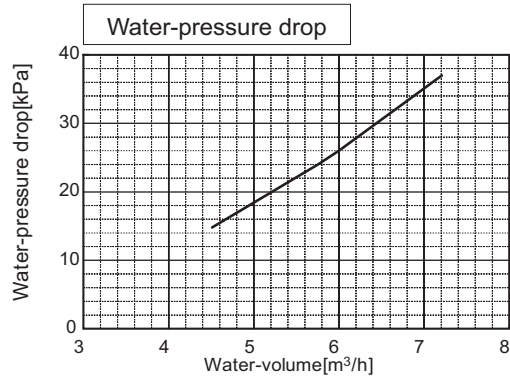
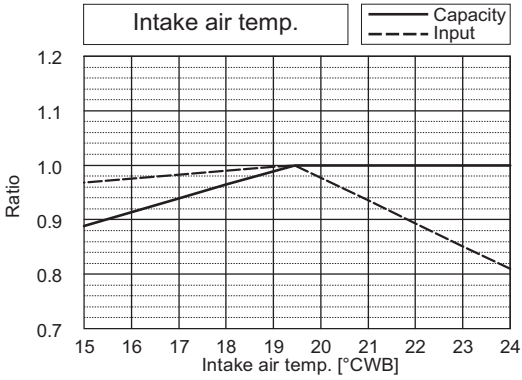
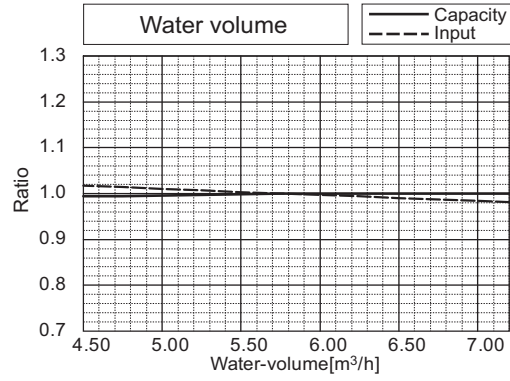
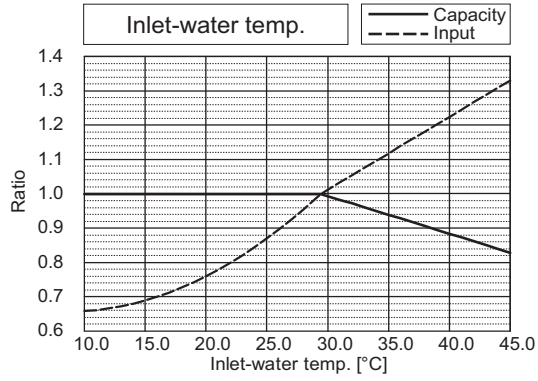

PQHY-			P120ZKMU		
Nominal Heating Capacity	kW	39.6	Rated Heating Capacity	kW	37.8
	BTU/h	135,000		BTU/h	129,000
Input	kW	7.99	Input	kW	(Non-Ducted) 7.43 (Ducted) 7.44

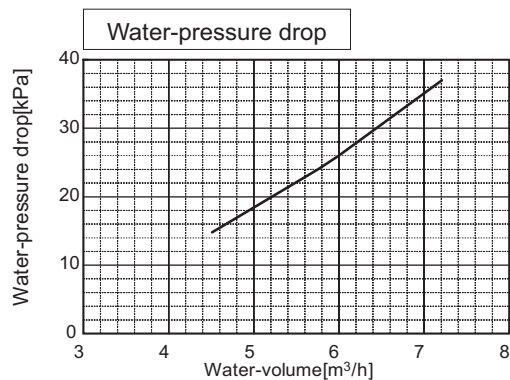
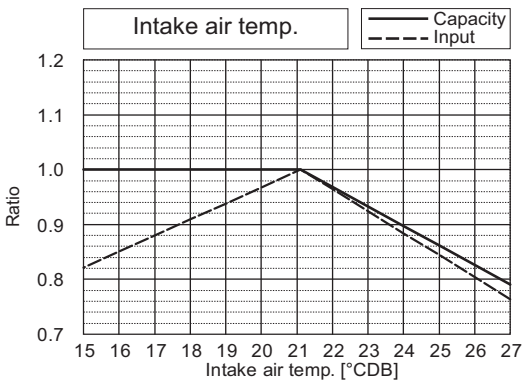
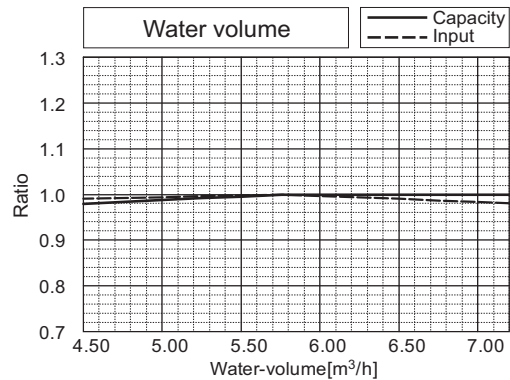
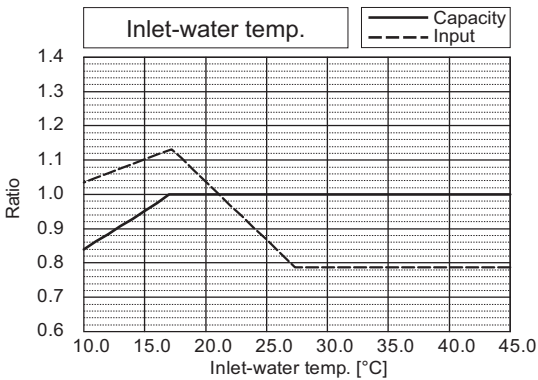

WY 575V

6. CAPACITY TABLES

PQHY-			P144ZSKMU		
Nominal Cooling Capacity	kW	42.2	Rated Cooling Capacity	kW	40.2
	BTU/h	144,000		BTU/h	137,000
Input	kW	9.21	Input	kW	(Non-Ducted) 6.47 (Ducted) 8.57

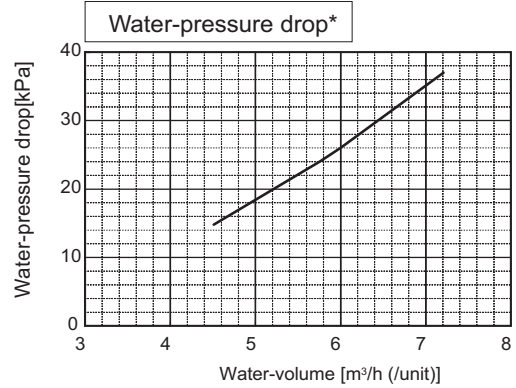
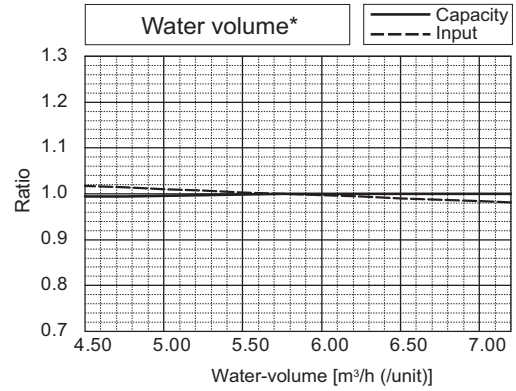
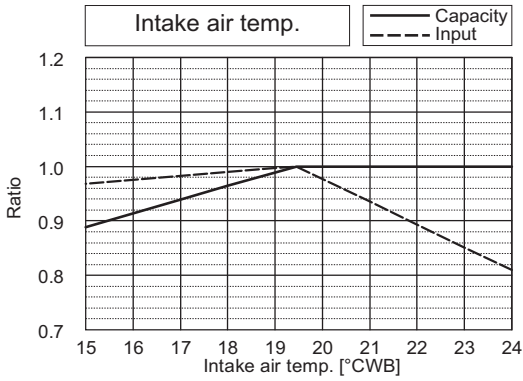
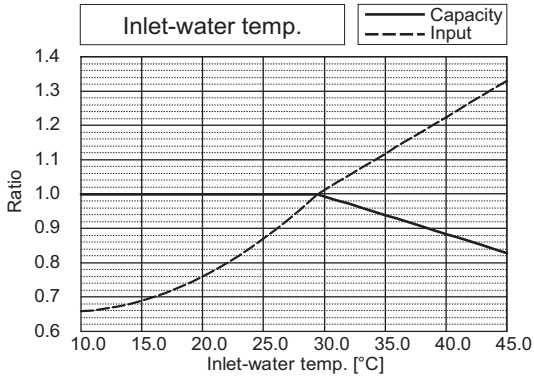

*The drawing indicates characteristic per unit.

PQHY-			P144ZSKMU		
Nominal Heating Capacity	kW	46.9	Rated Heating Capacity	kW	44.5
	BTU/h	160,000		BTU/h	152,000
Input	kW	8.78	Input	kW	(Non-Ducted) 7.51 (Ducted) 8.17

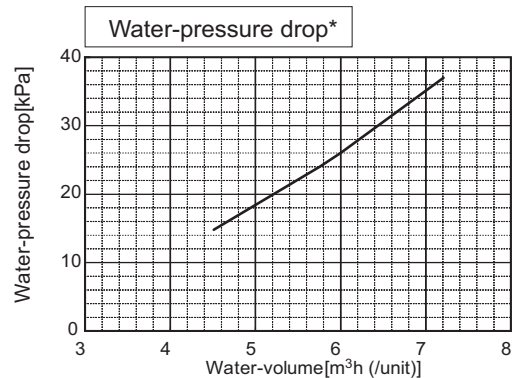
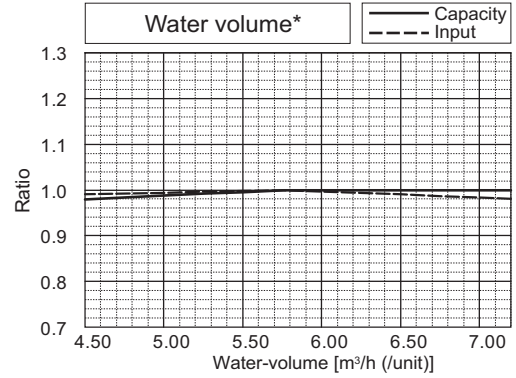
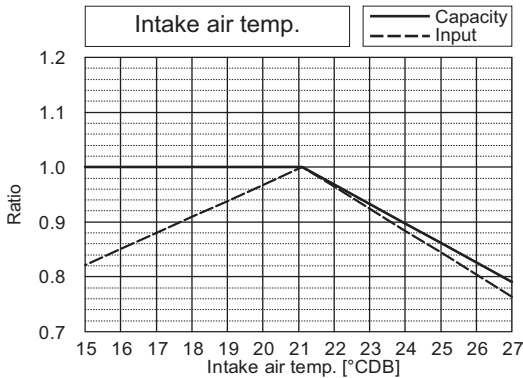
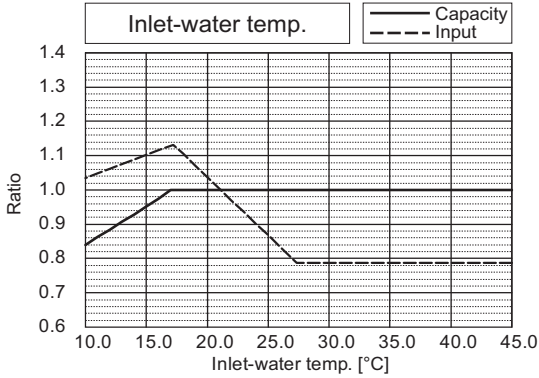

*The drawing indicates characteristic per unit.

WY 575V

6. CAPACITY TABLES

PQHY-			P168ZSKMU		
Nominal Cooling Capacity	kW	49.2	Rated Cooling Capacity	kW	47.2
	BTU/h	168,000		BTU/h	161,000
Input	kW	10.67	Input	kW	(Non-Ducted) 8.48 (Ducted) 9.93

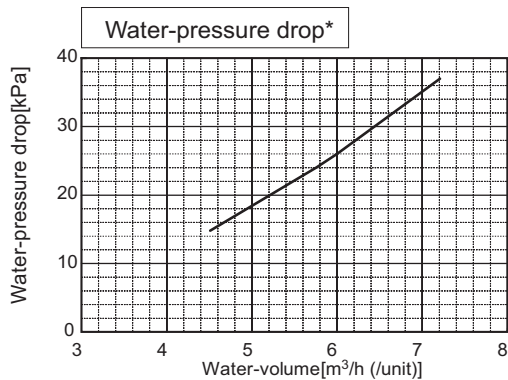
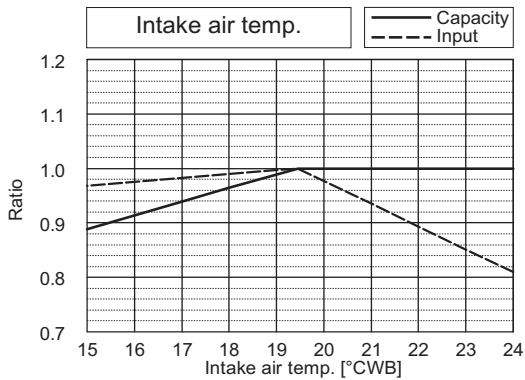
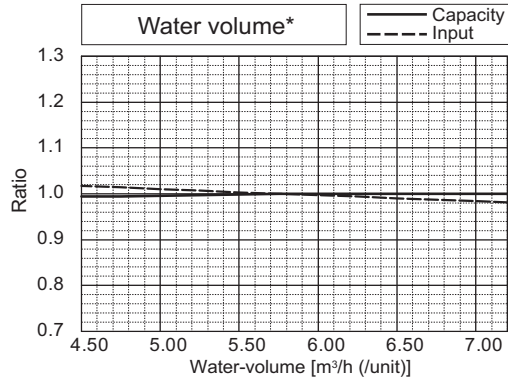
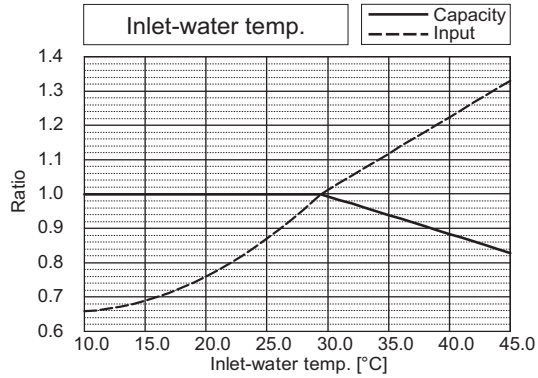

*The drawing indicates characteristic per unit.

PQHY-			P168ZSKMU		
Nominal Heating Capacity	kW	55.1	Rated Heating Capacity	kW	52.5
	BTU/h	188,000		BTU/h	179,000
Input	kW	10.73	Input	kW	(Non-Ducted) 9.44 (Ducted) 9.99

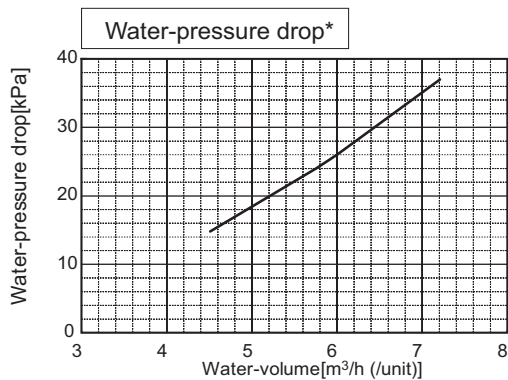
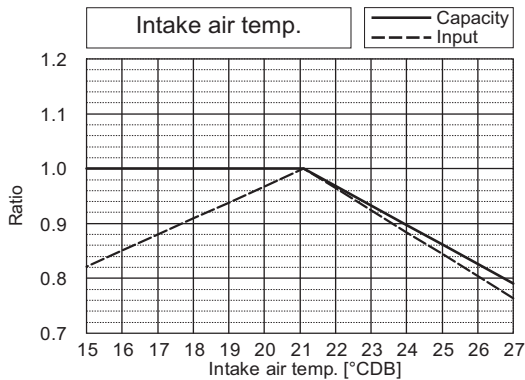
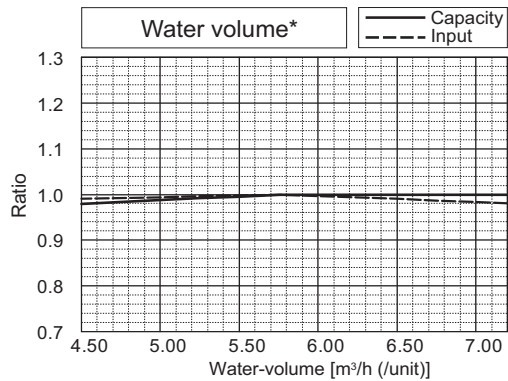
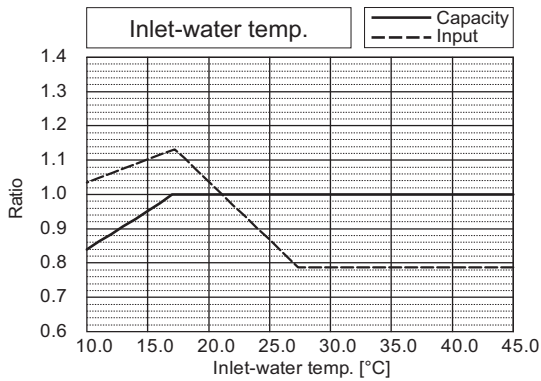

*The drawing indicates characteristic per unit.

WY 575V

6. CAPACITY TABLES

PQHY-		P192ZSKMU			
Nominal Cooling Capacity	kW	56.3	Rated Cooling Capacity	kW	53.6
	BTU/h	192,000		BTU/h	183,000
Input	kW	12.60	Input	kW	(Non-Ducted) 10.28 (Ducted) 11.73

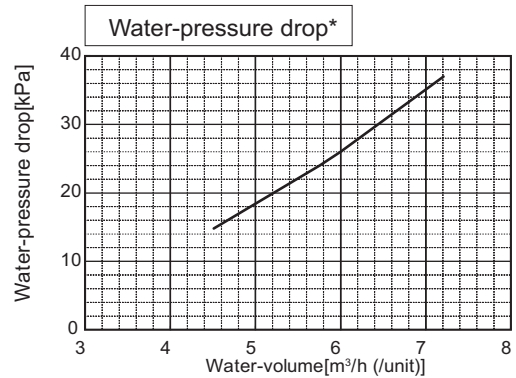
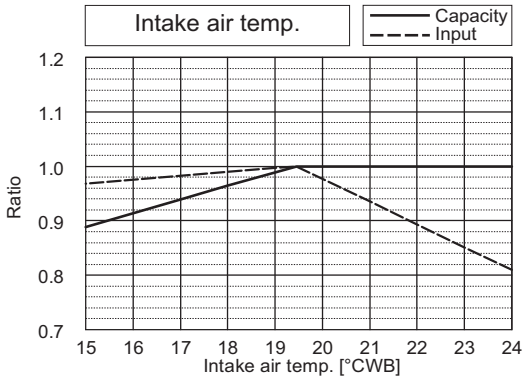
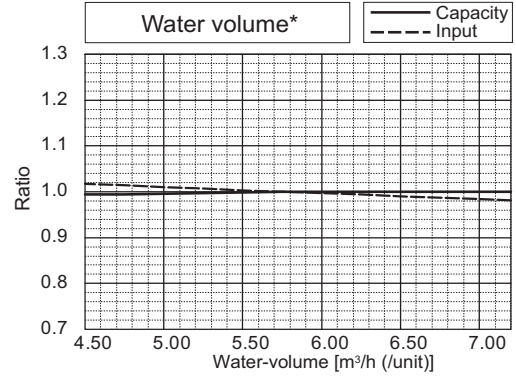
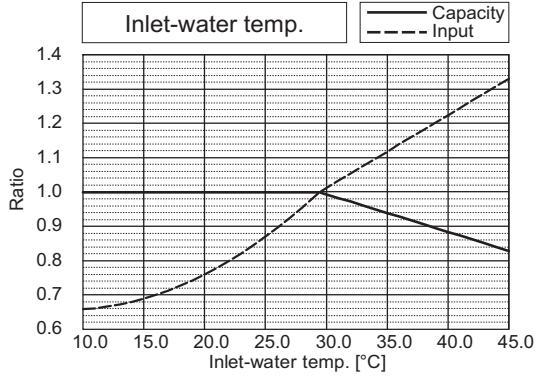

*The drawing indicates characteristic per unit.

PQHY-		P192ZSKMU			
Nominal Heating Capacity	kW	63.0	Rated Heating Capacity	kW	60.1
	BTU/h	215,000		BTU/h	205,000
Input	kW	13.01	Input	kW	(Non-Ducted) 11.19 (Ducted) 12.11

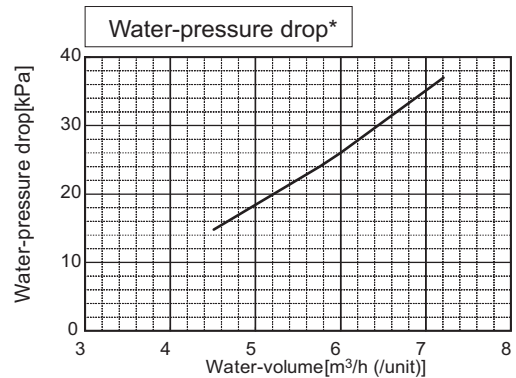
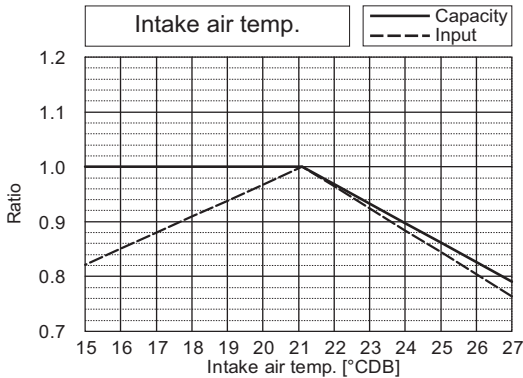
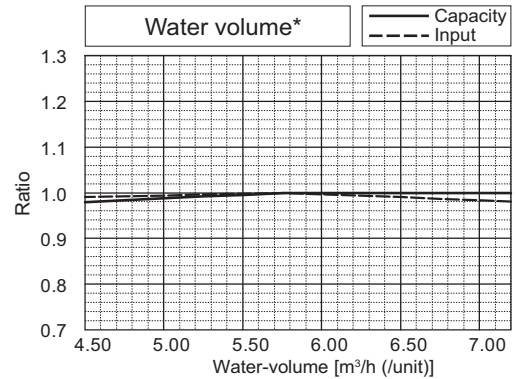
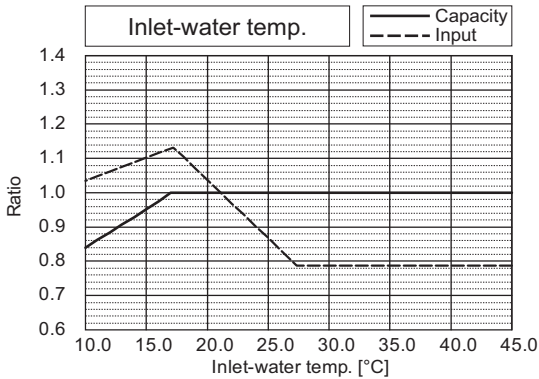

*The drawing indicates characteristic per unit.

WY 575V

6. CAPACITY TABLES

PQHY-			P216ZSKMU		
Nominal Cooling Capacity	kW	63.3	Rated Cooling Capacity	kW	60.4
	BTU/h	216,000		BTU/h	206,000
Input	kW	14.60	Input	kW	(Non-Ducted) 12.77 (Ducted) 13.59

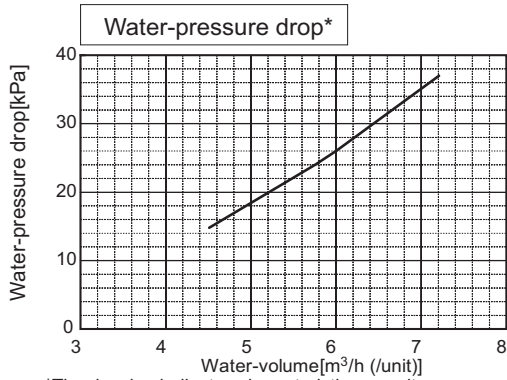
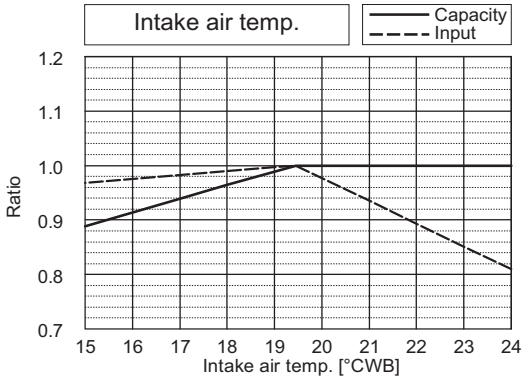
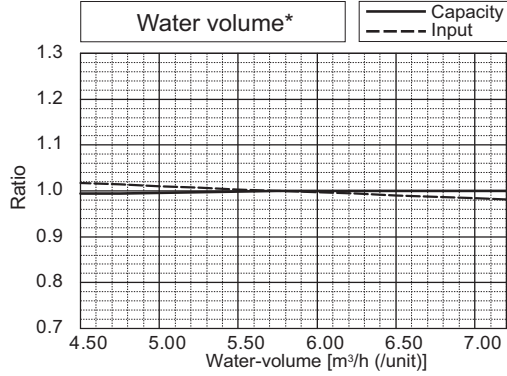
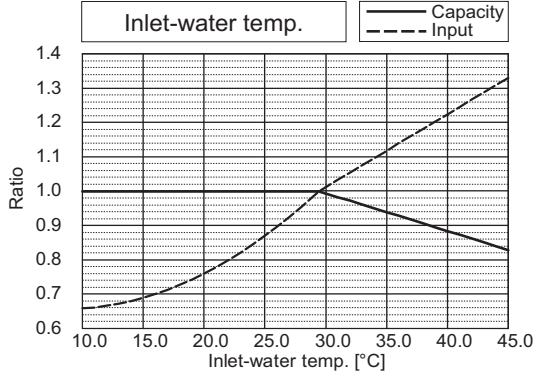

*The drawing indicates characteristic per unit.

PQHY-			P216ZSKMU		
Nominal Heating Capacity	kW	71.2	Rated Heating Capacity	kW	68.0
	BTU/h	243,000		BTU/h	232,000
Input	kW	14.97	Input	kW	(Non-Ducted) 13.88 (Ducted) 13.93

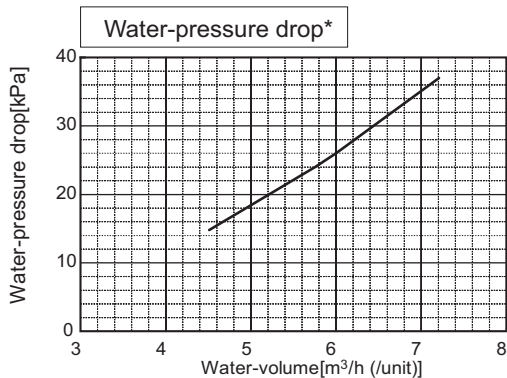
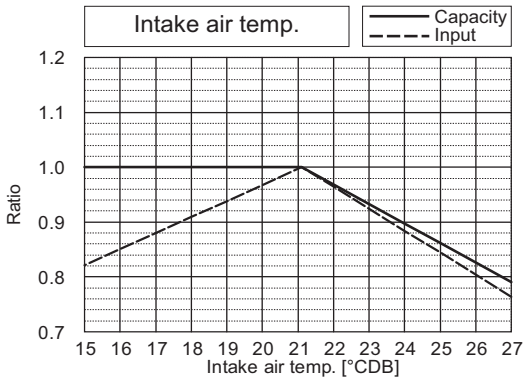
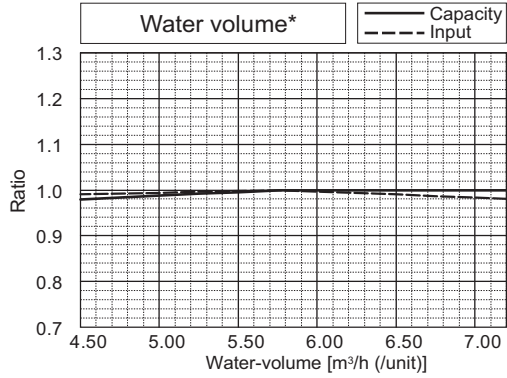
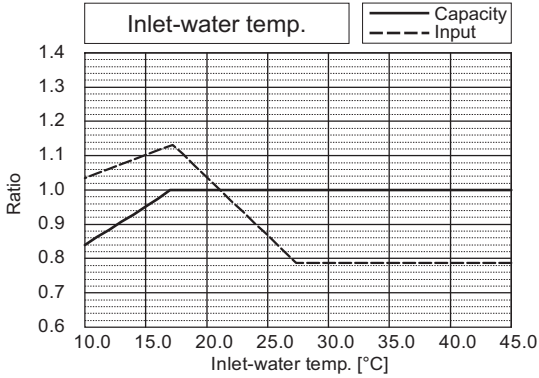

*The drawing indicates characteristic per unit.

WY 575V

6. CAPACITY TABLES

PQHY-			P240ZSKMU		
Nominal Cooling Capacity	kW	70.3	Rated Cooling Capacity	kW	66.8
	BTU/h	240,000		BTU/h	228,000
Input	kW	18.17	Input	kW	(Non-Ducted) 15.63 (Ducted) 16.91

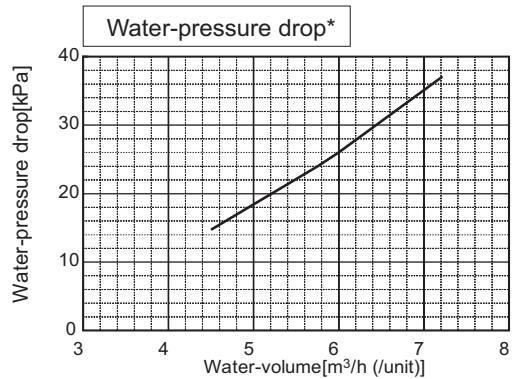
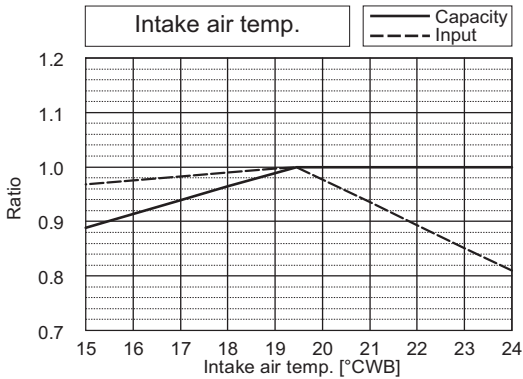
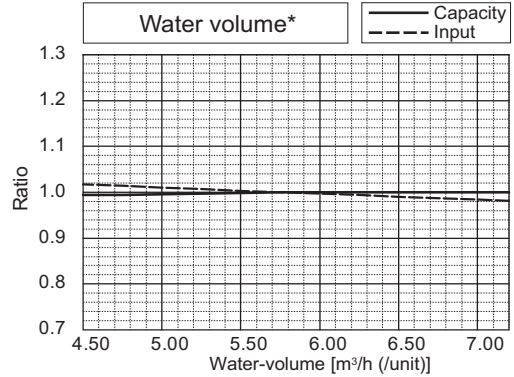
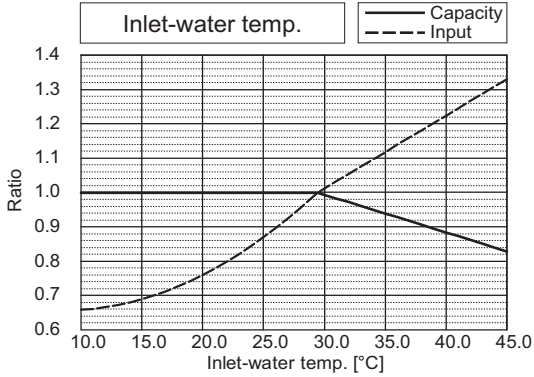

*The drawing indicates characteristic per unit.

PQHY-			P240ZSKMU		
Nominal Heating Capacity	kW	79.1	Rated Heating Capacity	kW	75.6
	BTU/h	270,000		BTU/h	258,000
Input	kW	17.14	Input	kW	(Non-Ducted) 16.78 (Ducted) 15.95

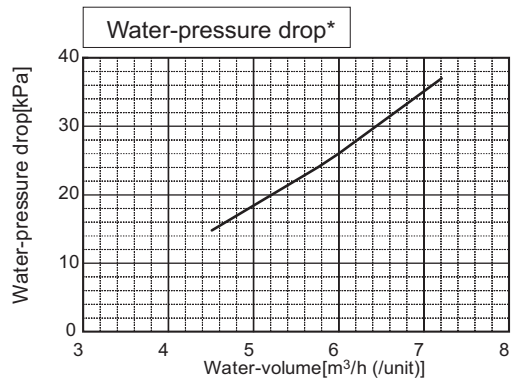
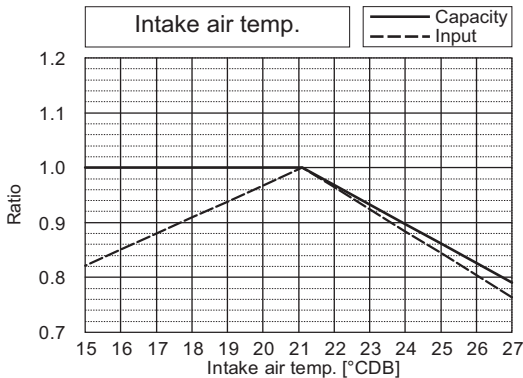
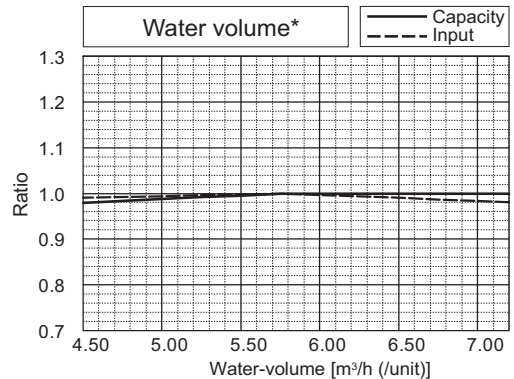
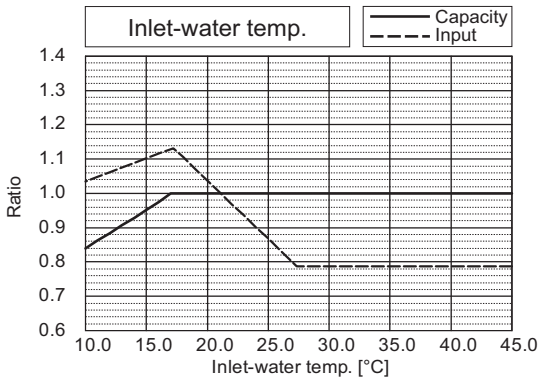

*The drawing indicates characteristic per unit.

WY 575V

6. CAPACITY TABLES

PQHY-		P264ZSKMU			
Nominal Cooling Capacity	kW	77.4	Rated Cooling Capacity	kW	73.9
	BTU/h	264,000		BTU/h	252,000
Input	kW	17.96	Input	kW	(Non-Ducted) 14.61 (Ducted) 16.71

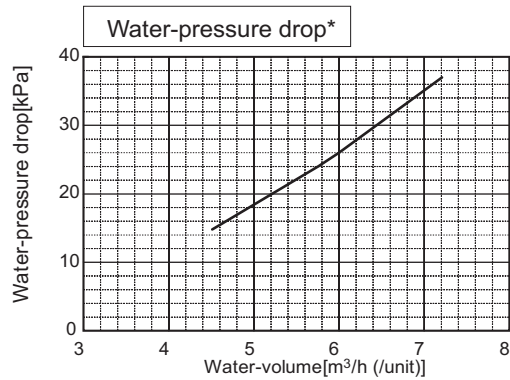
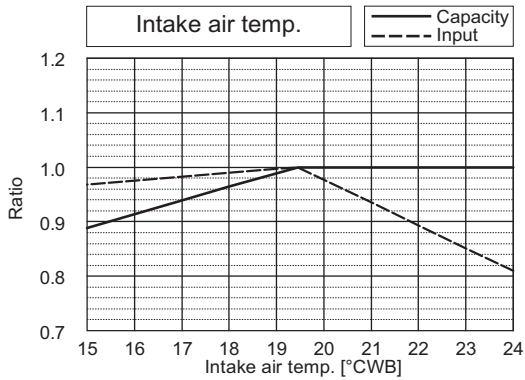
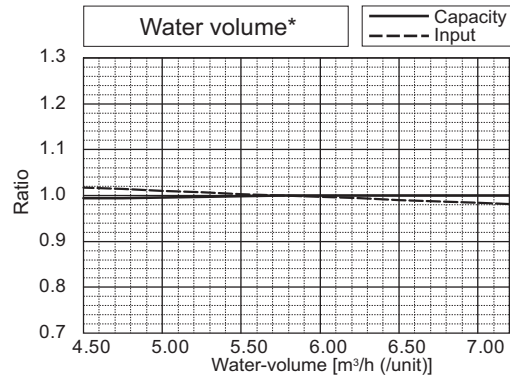
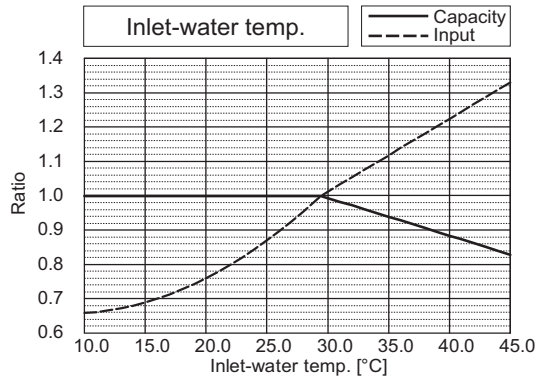

*The drawing indicates characteristic per unit.

PQHY-		P264ZSKMU			
Nominal Heating Capacity	kW	86.5	Rated Heating Capacity	kW	82.4
	BTU/h	295,000		BTU/h	281,000
Input	kW	17.27	Input	kW	(Non-Ducted) 15.52 (Ducted) 16.07

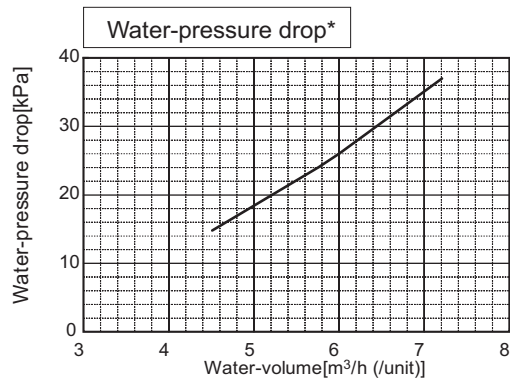
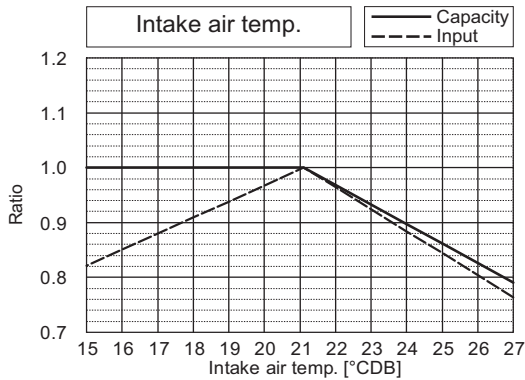
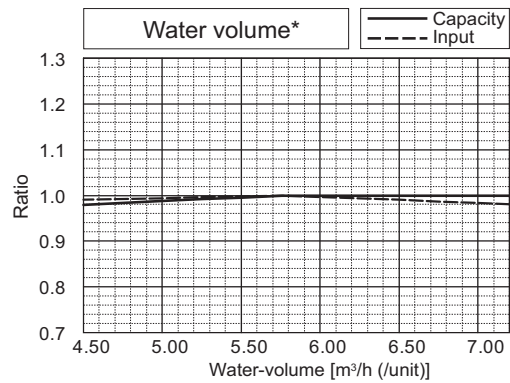
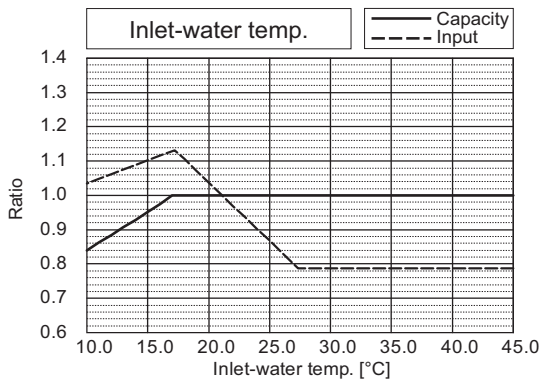

*The drawing indicates characteristic per unit.

WY 575V

6. CAPACITY TABLES

PQHY-		P288ZSKMU			
Nominal Cooling Capacity	kW	84.4	Rated Cooling Capacity	kW	80.6
	BTU/h	288,000		BTU/h	275,000
Input	kW	19.98	Input	kW	(Non-Ducted) 16.42 (Ducted) 18.59

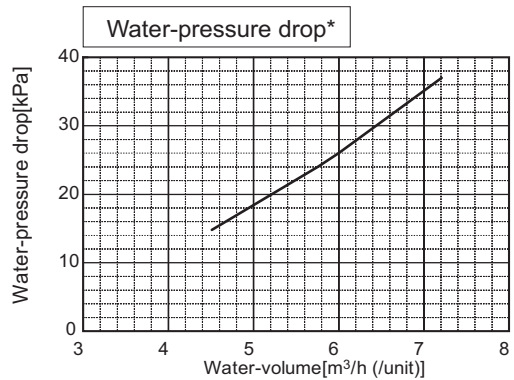
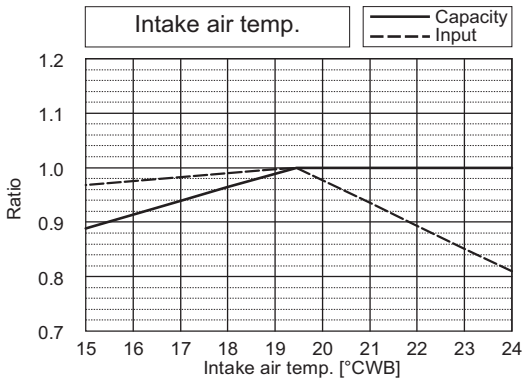
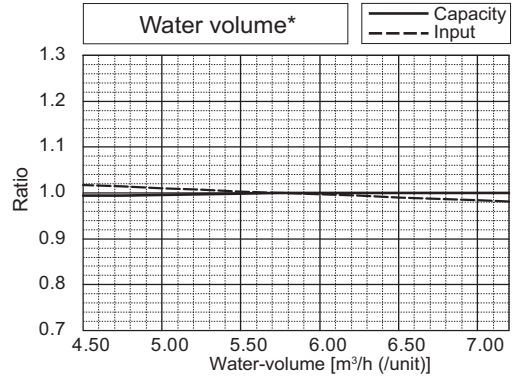
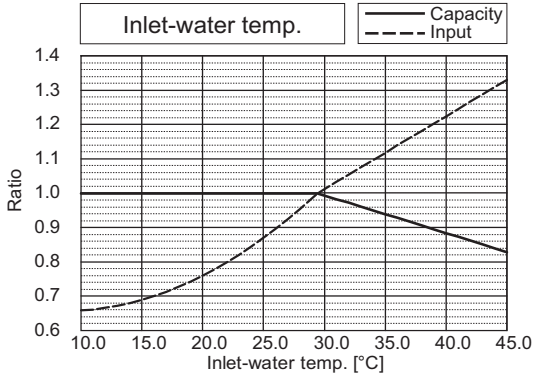

*The drawing indicates characteristic per unit.

PQHY-		P288ZSKMU			
Nominal Heating Capacity	kW	94.7	Rated Heating Capacity	kW	90.3
	BTU/h	323,000		BTU/h	308,000
Input	kW	19.55	Input	kW	(Non-Ducted) 17.31 (Ducted) 18.19

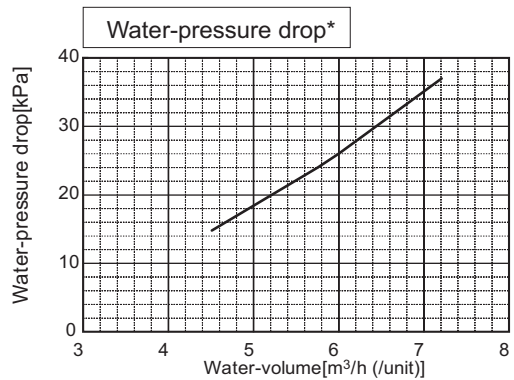
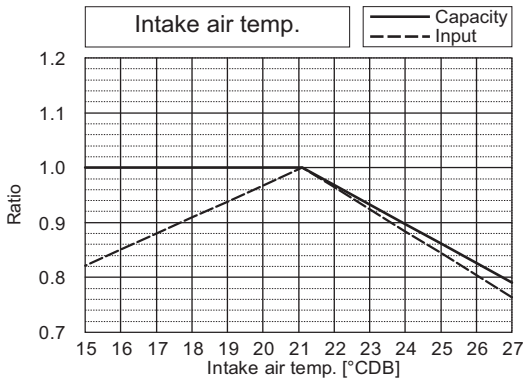
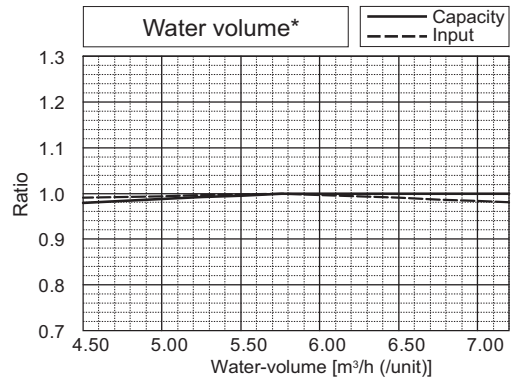
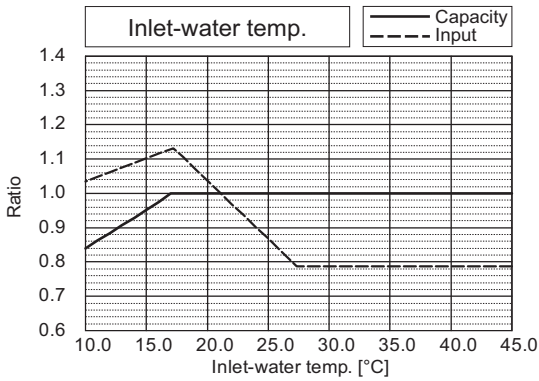

*The drawing indicates characteristic per unit.

WY 575V

6. CAPACITY TABLES

PQHY-			P312ZSKMU		
Nominal Cooling Capacity	kW	91.4	Rated Cooling Capacity	kW	87.0
	BTU/h	312,000		BTU/h	297,000
Input	kW	22.41	Input	kW	(Non-Ducted) 19.28 (Ducted) 20.85

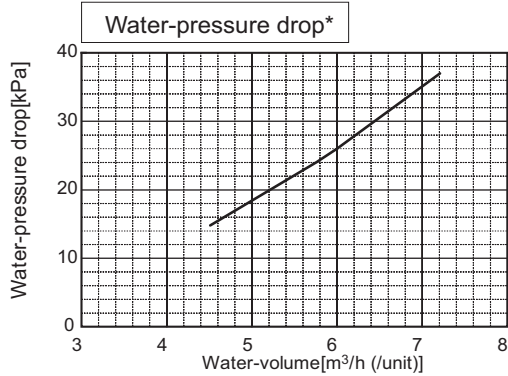
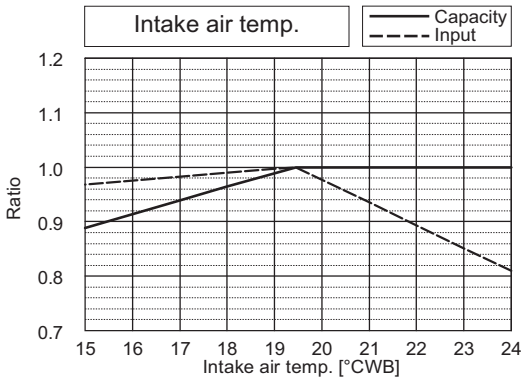
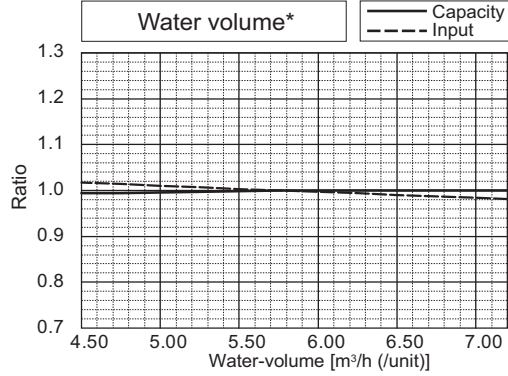
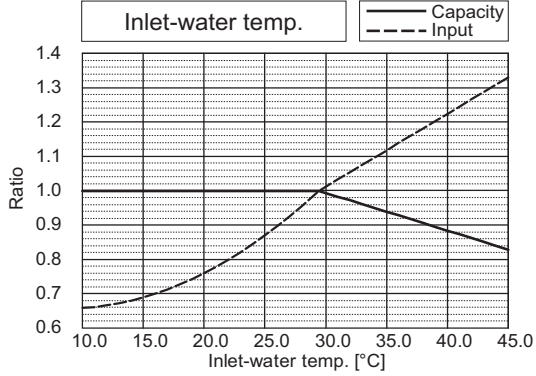

*The drawing indicates characteristic per unit.

PQHY-			P312ZSKMU		
Nominal Heating Capacity	kW	102.6	Rated Heating Capacity	kW	97.9
	BTU/h	350,000		BTU/h	334,000
Input	kW	21.52	Input	kW	(Non-Ducted) 20.10 (Ducted) 20.02

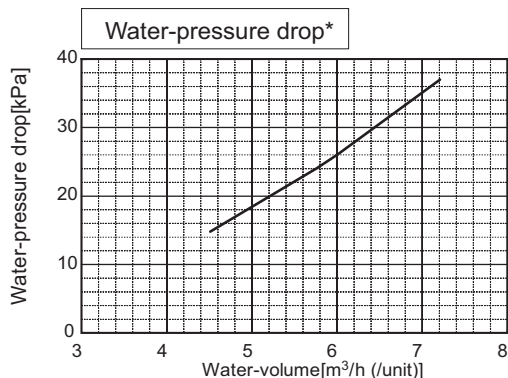
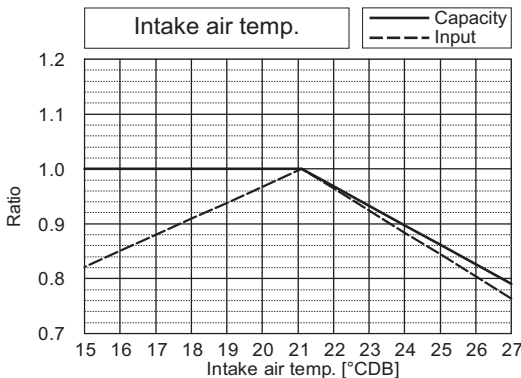
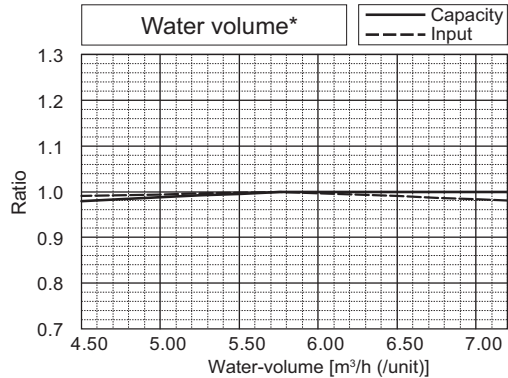
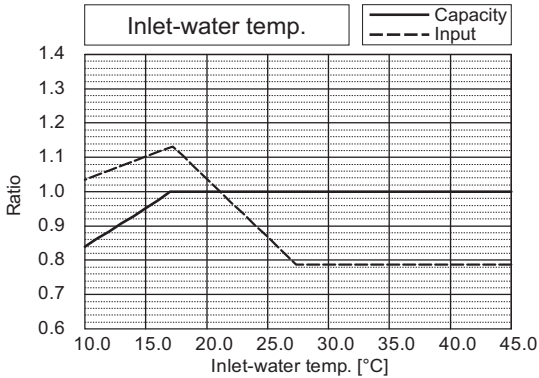

*The drawing indicates characteristic per unit.

WY 575V

6. CAPACITY TABLES

PQHY-			P336ZSKMU		
Nominal Cooling Capacity	kW	98.5	Rated Cooling Capacity	kW	93.8
	BTU/h	336,000		BTU/h	320,000
Input	kW	24.86	Input	kW	(Non-Ducted) 22.51 (Ducted) 23.13

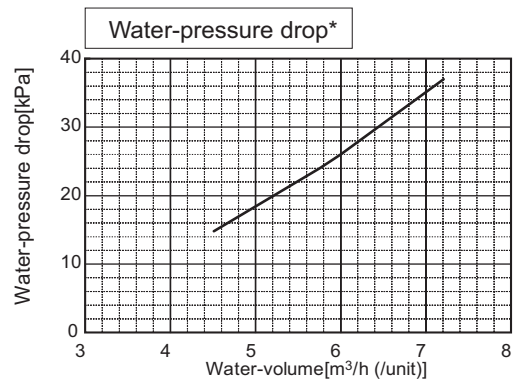
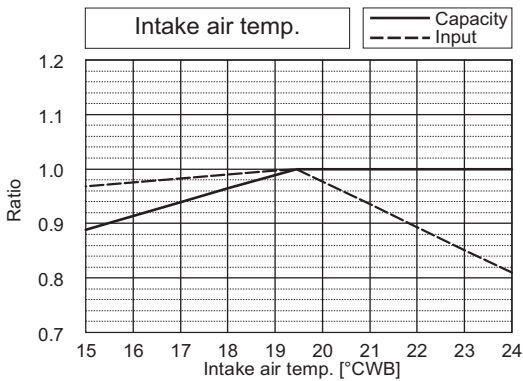
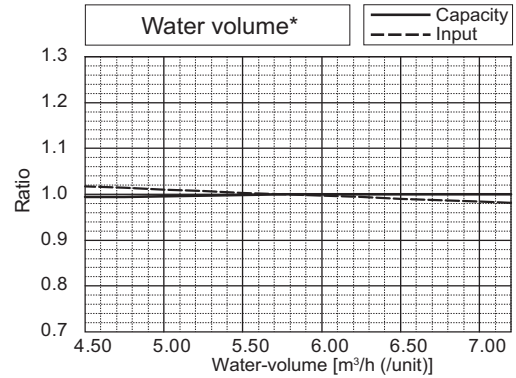
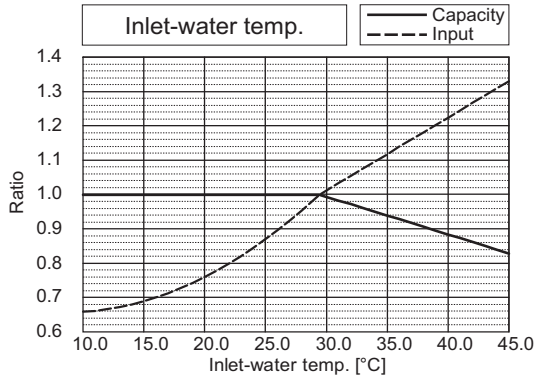

*The drawing indicates characteristic per unit.

PQHY-			P336ZSKMU		
Nominal Heating Capacity	kW	110.8	Rated Heating Capacity	kW	105.8
	BTU/h	378,000		BTU/h	361,000
Input	kW	23.68	Input	kW	(Non-Ducted) 23.32 (Ducted) 22.03

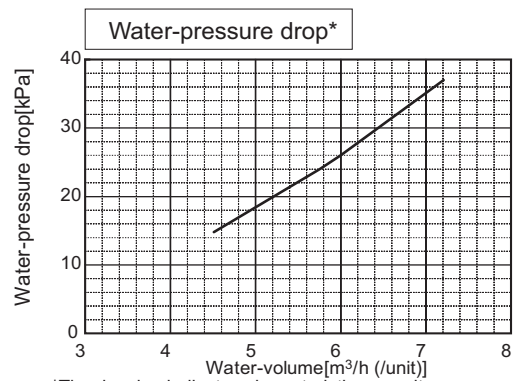
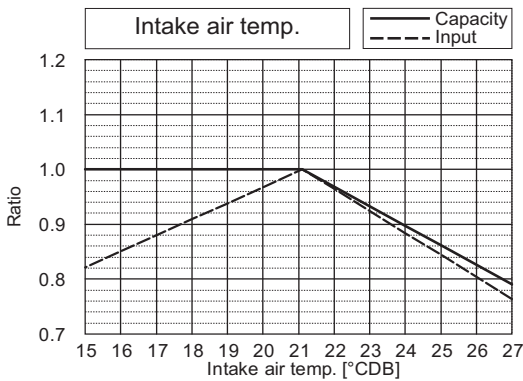
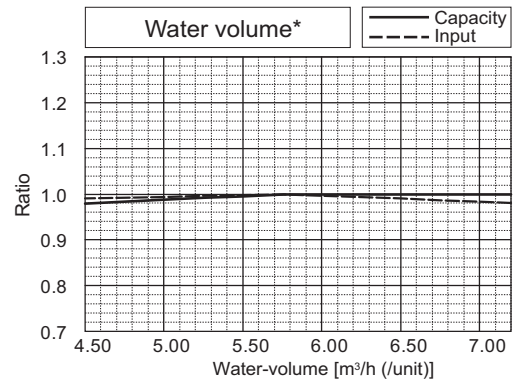
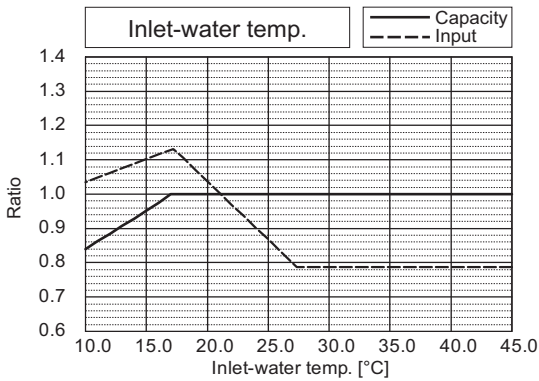

*The drawing indicates characteristic per unit.

WY 575V

6. CAPACITY TABLES

PQHY-			P360ZSKMU		
Nominal Cooling Capacity	kW	105.5	Rated Cooling Capacity	kW	100.2
	BTU/h	360,000		BTU/h	342,000
Input	kW	27.35	Input	kW	(Non-Ducted) 26.39 (Ducted) 25.45

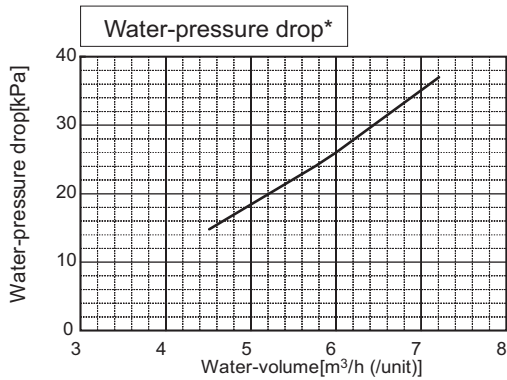
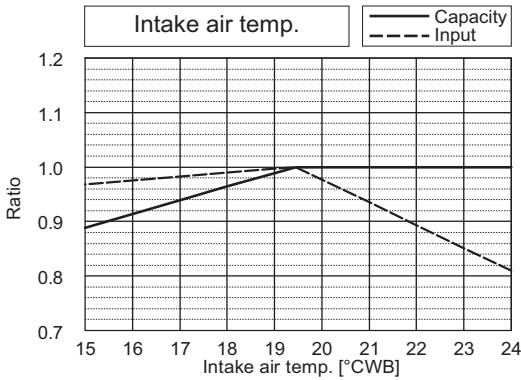
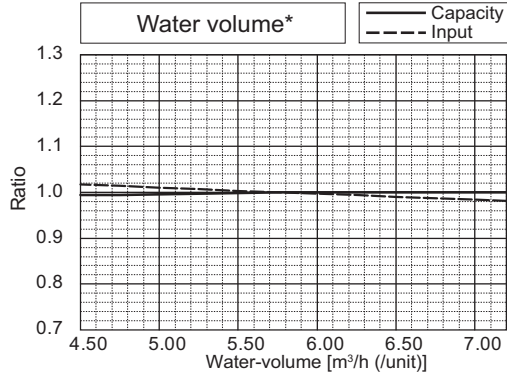
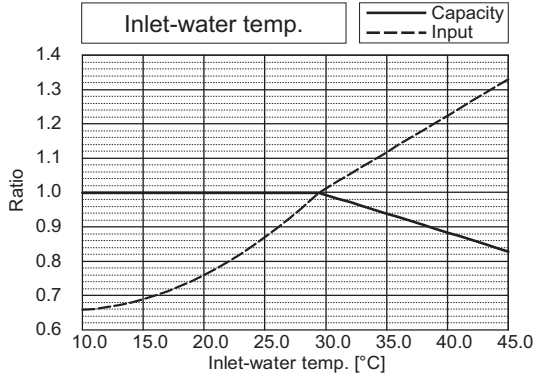

*The drawing indicates characteristic per unit.

PQHY-			P360ZSKMU		
Nominal Heating Capacity	kW	118.7	Rated Heating Capacity	kW	113.4
	BTU/h	405,000		BTU/h	387,000
Input	kW	25.75	Input	kW	(Non-Ducted) 26.85 (Ducted) 23.96

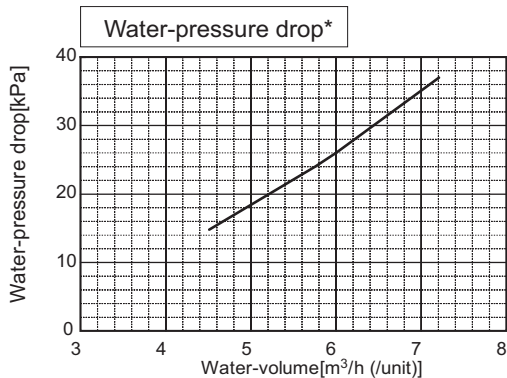
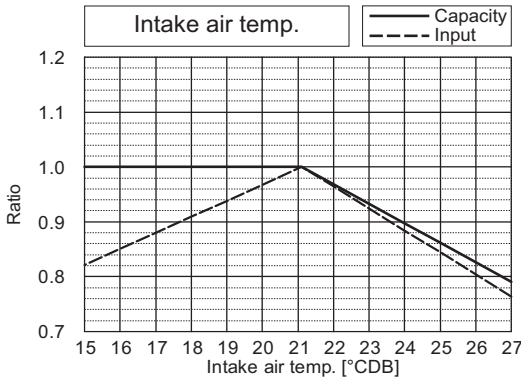
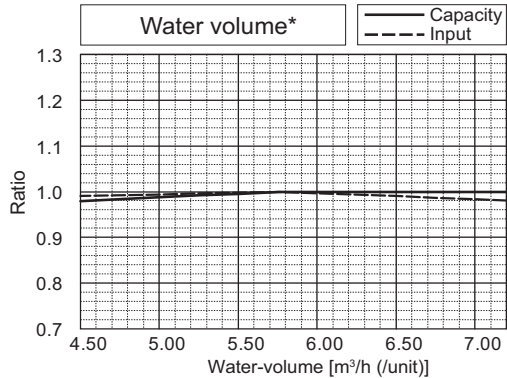
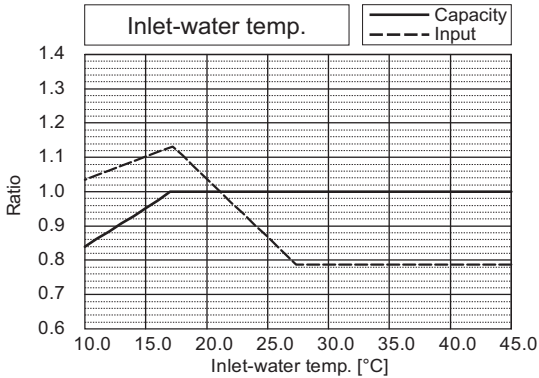

*The drawing indicates characteristic per unit.

WY 575V

PQHY-			P72ZKMU		
Nominal Cooling Capacity	kW	21.1	Rated Cooling Capacity	kW	20.2
	BTU/h	72,000		BTU/h	69,000
Input	kW	3.75	Input	kW	(Non-Ducted) 2.96 (Ducted) 3.49

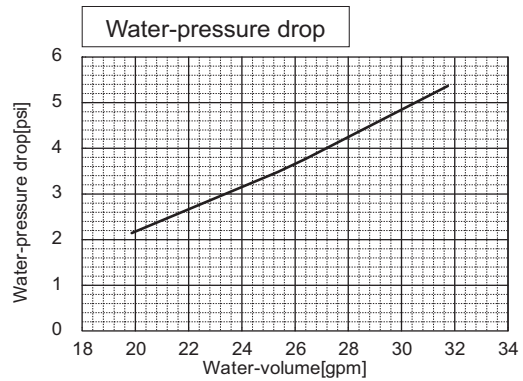
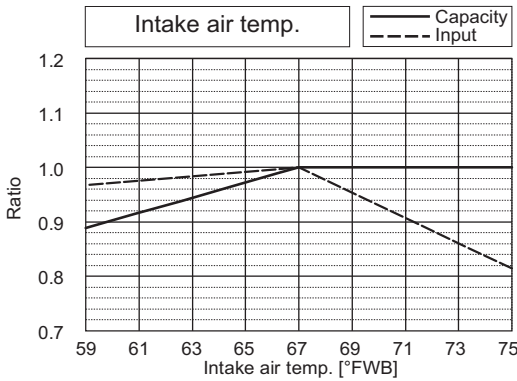
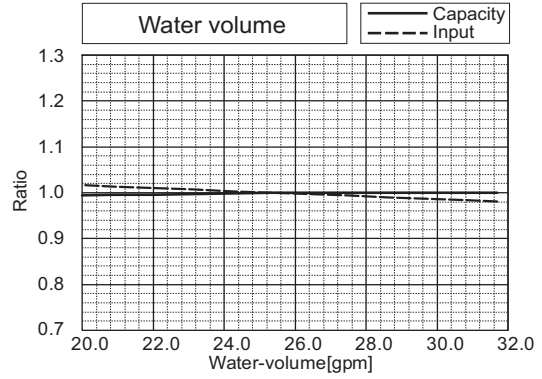
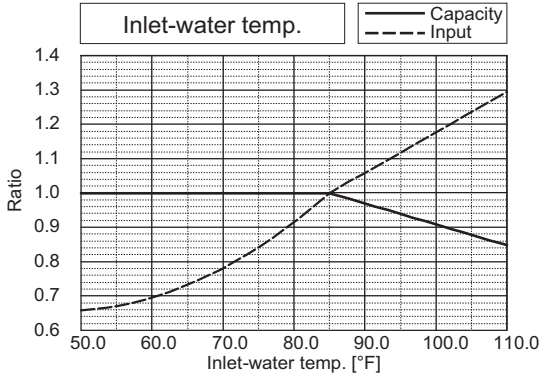

PQHY-			P72ZKMU		
Nominal Heating Capacity	kW	23.4	Rated Heating Capacity	kW	22.3
	BTU/h	80,000		BTU/h	76,000
Input	kW	3.93	Input	kW	(Non-Ducted) 3.48 (Ducted) 3.66

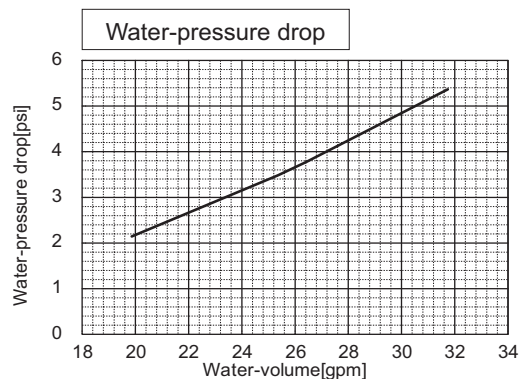
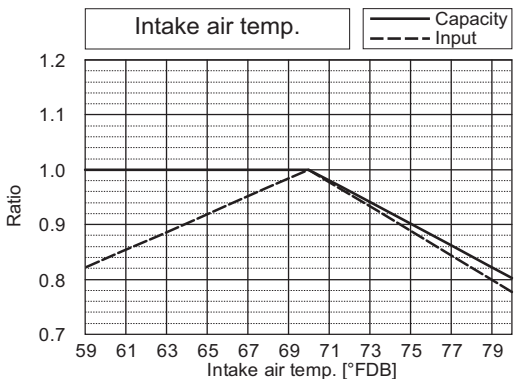
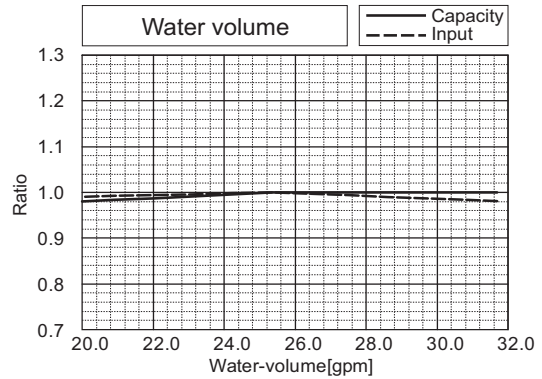
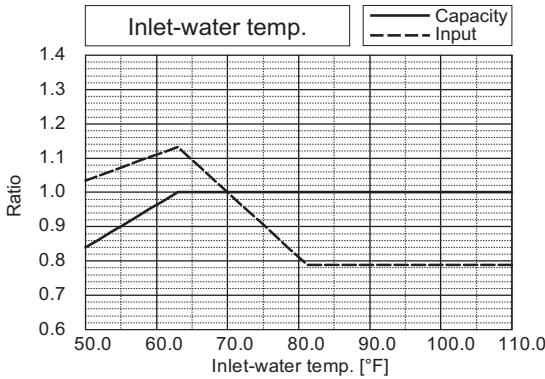

WY 575V

6. CAPACITY TABLES

PQHY-			P96ZKMU		
Nominal Cooling Capacity	kW	28.1	Rated Cooling Capacity	kW	27.0
	BTU/h	96,000		BTU/h	92,000
Input	kW	5.93	Input	kW	(Non-Ducted) 4.26 (Ducted) 5.52

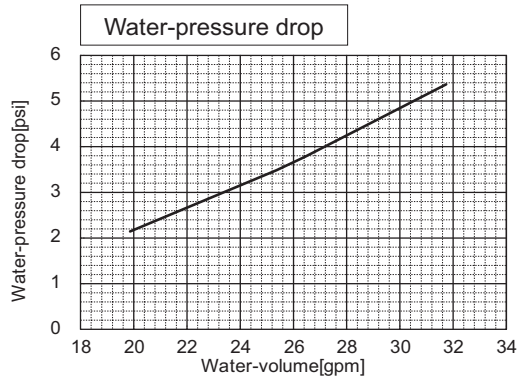
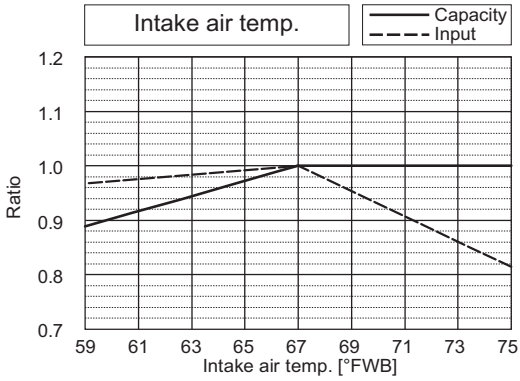
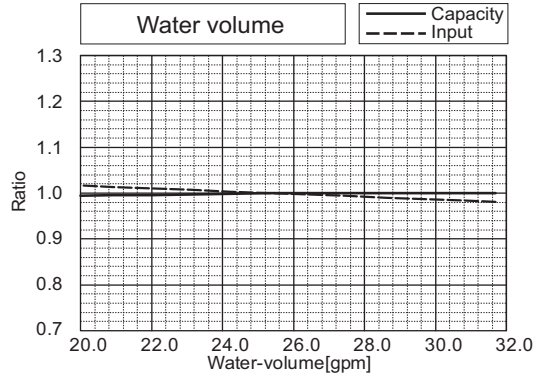
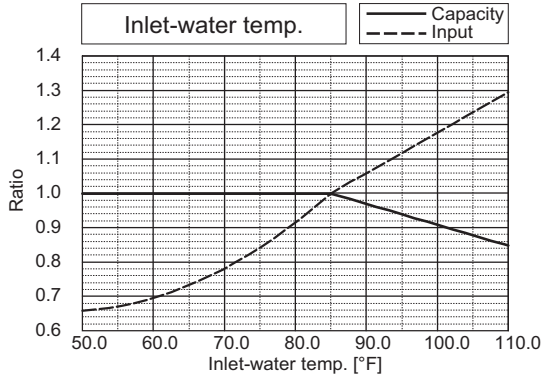

PQHY-			P96ZKMU		
Nominal Heating Capacity	kW	31.7	Rated Heating Capacity	kW	30.2
	BTU/h	108,000		BTU/h	103,000
Input	kW	6.17	Input	kW	(Non-Ducted) 4.87 (Ducted) 5.74

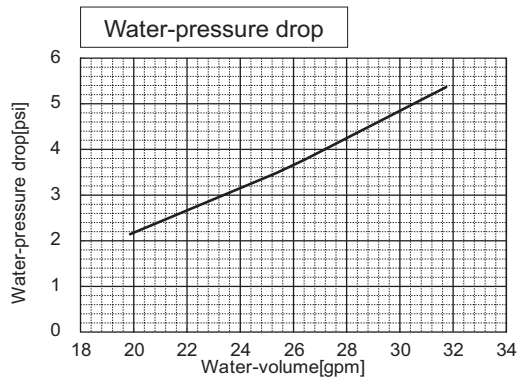
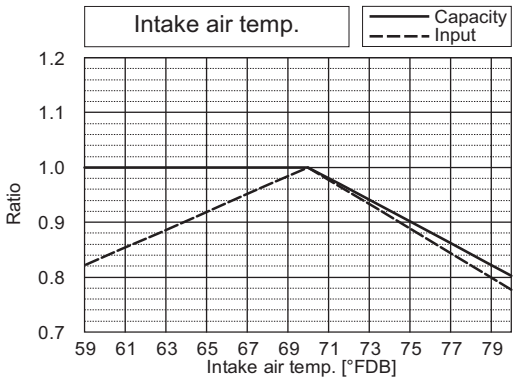
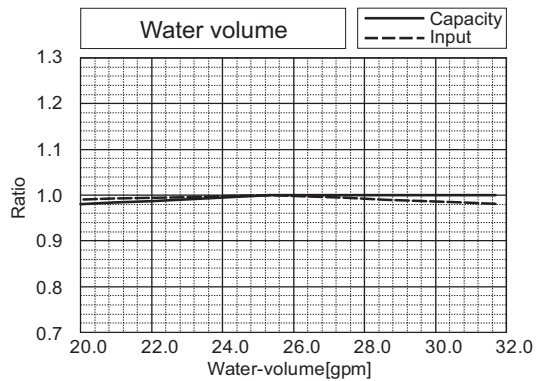
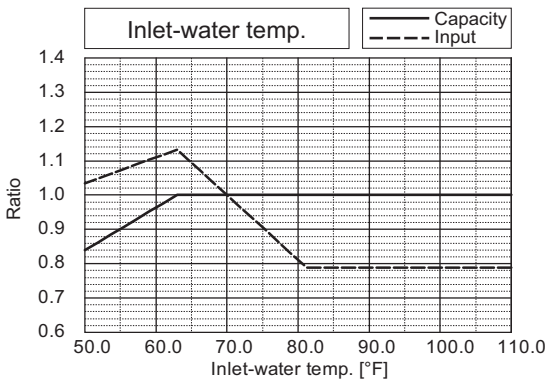

WY 575V

6. CAPACITY TABLES

PQHY-			P120ZKMU		
Nominal Cooling Capacity	kW	35.2	Rated Cooling Capacity	kW	33.4
	BTU/h	120,000		BTU/h	114,000
Input	kW	7.90	Input	kW	(Non-Ducted) 6.72 (Ducted) 7.35

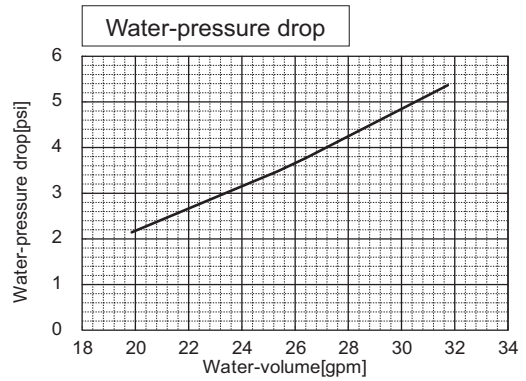
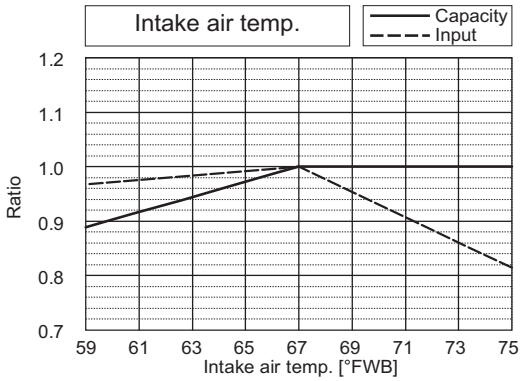
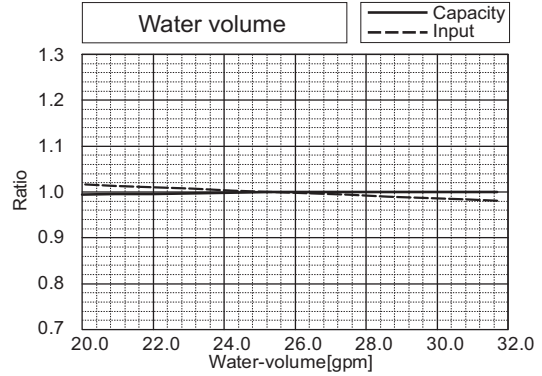
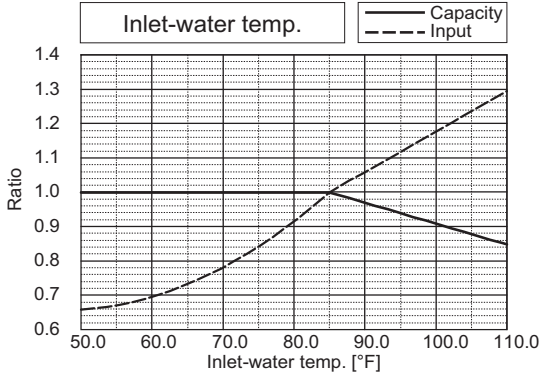

PQHY-			P120ZKMU		
Nominal Heating Capacity	kW	39.6	Rated Heating Capacity	kW	37.8
	BTU/h	135,000		BTU/h	129,000
Input	kW	7.99	Input	kW	(Non-Ducted) 7.43 (Ducted) 7.44

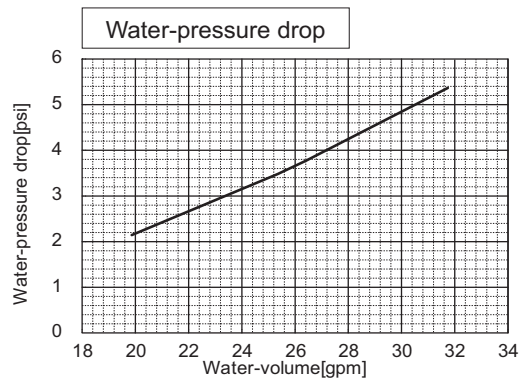
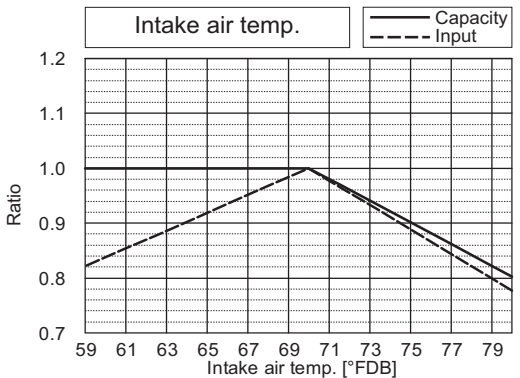
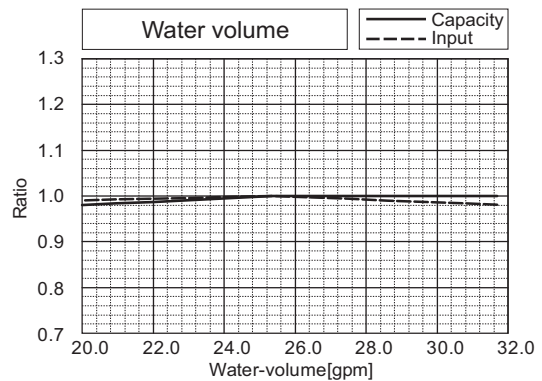
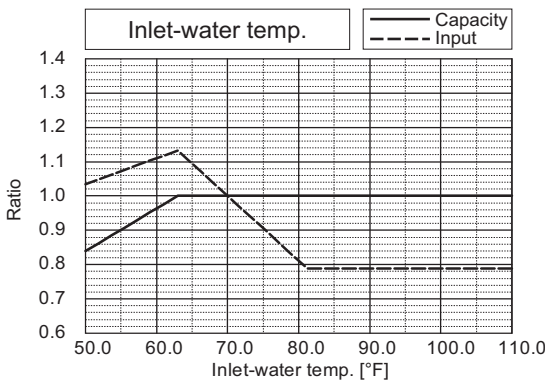

WY 575V

6. CAPACITY TABLES

PQHY-			P144ZSKMU		
Nominal Cooling Capacity	kW	42.2	Rated Cooling Capacity	kW	40.2
	BTU/h	144,000		BTU/h	137,000
Input	kW	9.21	Input	kW	(Non-Ducted) 6.47 (Ducted) 8.57

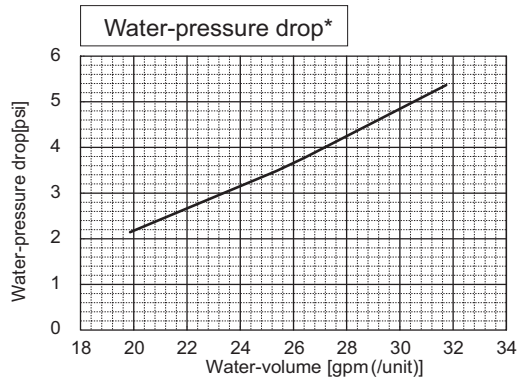
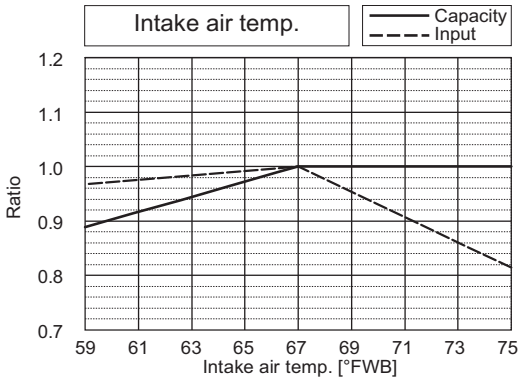
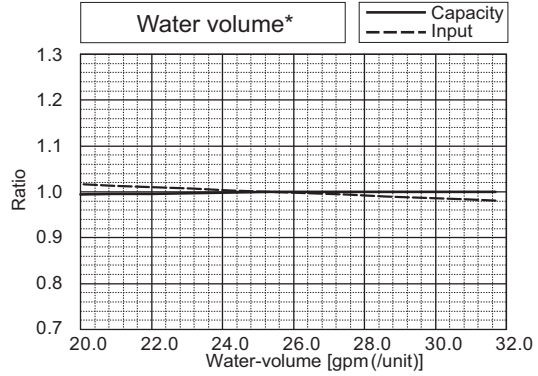
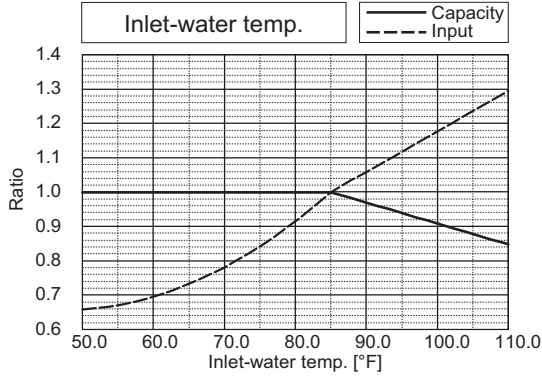

*The drawing indicates characteristic per unit.

PQHY-			P144ZSKMU		
Nominal Heating Capacity	kW	46.9	Rated Heating Capacity	kW	44.5
	BTU/h	160,000		BTU/h	152,000
Input	kW	8.78	Input	kW	(Non-Ducted) 7.51 (Ducted) 8.17

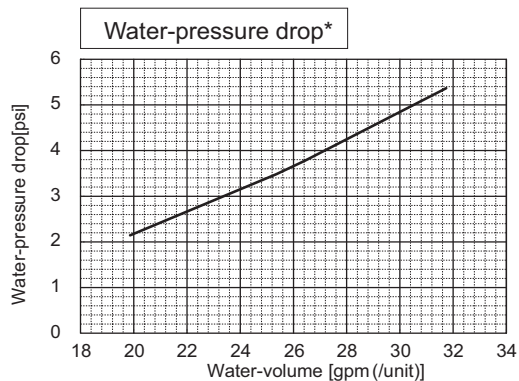
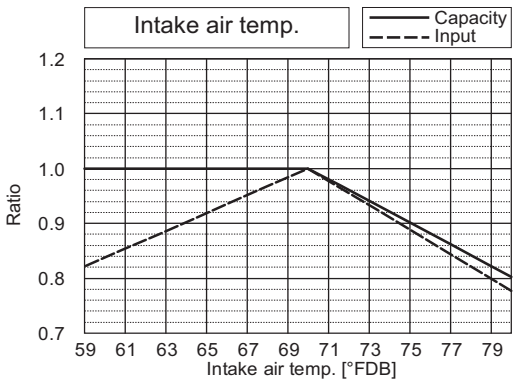
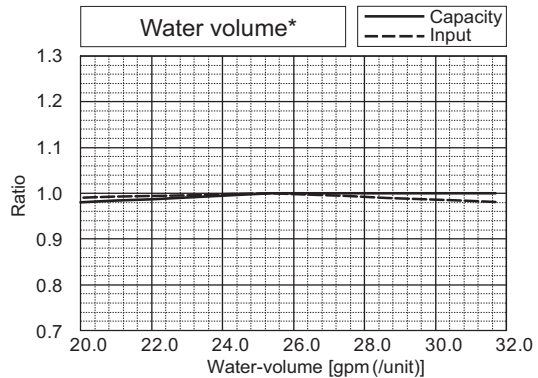
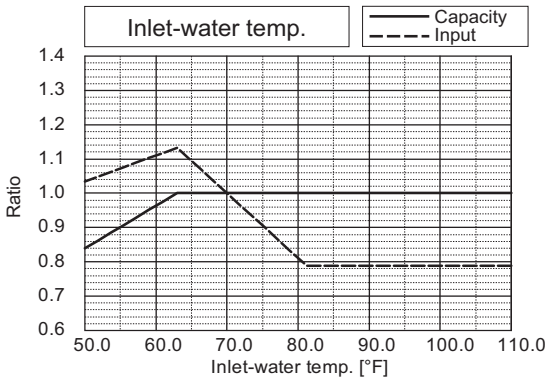

*The drawing indicates characteristic per unit.

WY 575V

6. CAPACITY TABLES

PQHY-			P168ZSKMU		
Nominal Cooling Capacity	kW	49.2	Rated Cooling Capacity	kW	47.2
	BTU/h	168,000		BTU/h	161,000
Input	kW	10.67	Input	kW	(Non-Ducted) 8.48 (Ducted) 9.93

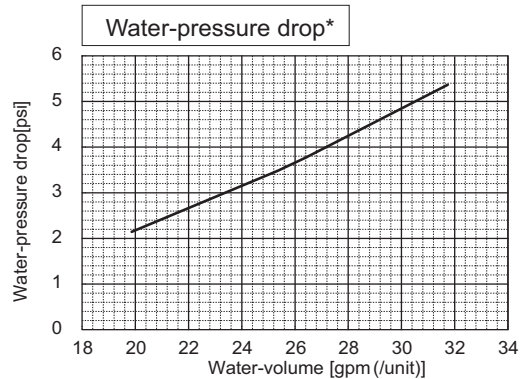
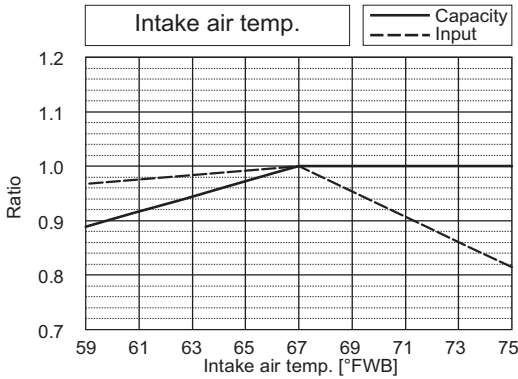
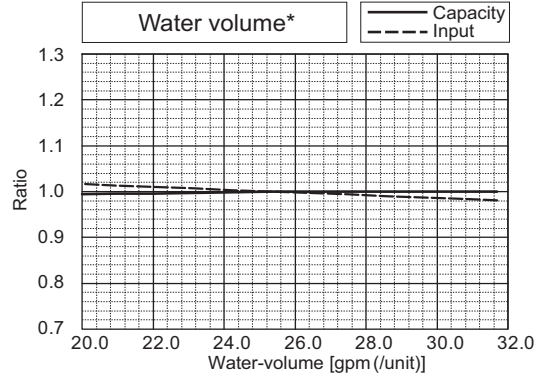
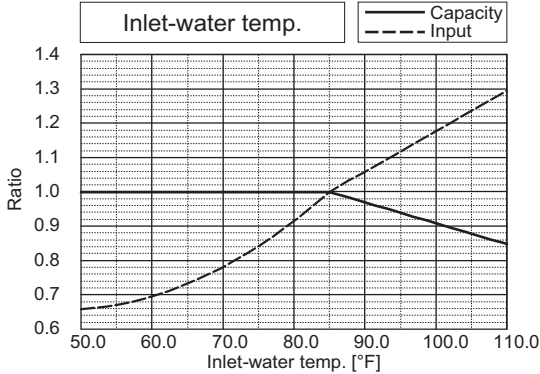

*The drawing indicates characteristic per unit.

PQHY-			P168ZSKMU		
Nominal Heating Capacity	kW	55.1	Rated Heating Capacity	kW	52.5
	BTU/h	188,000		BTU/h	179,000
Input	kW	10.73	Input	kW	(Non-Ducted) 9.44 (Ducted) 9.99

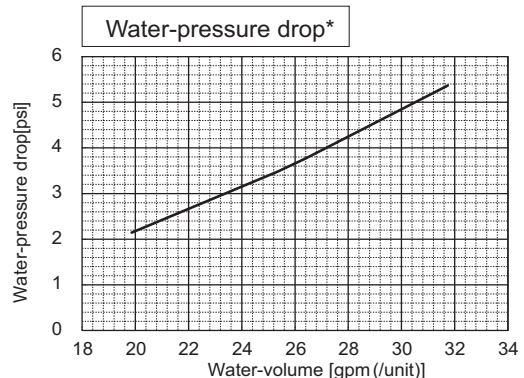
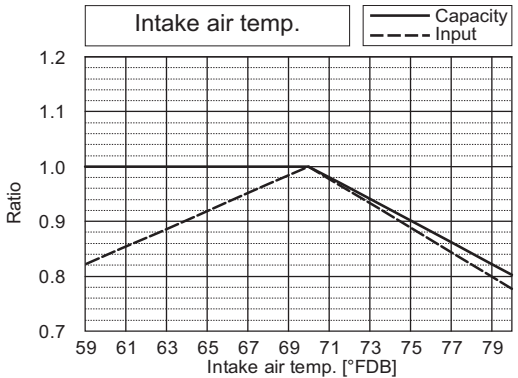
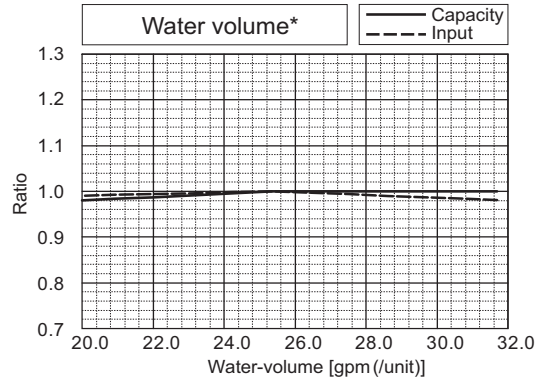
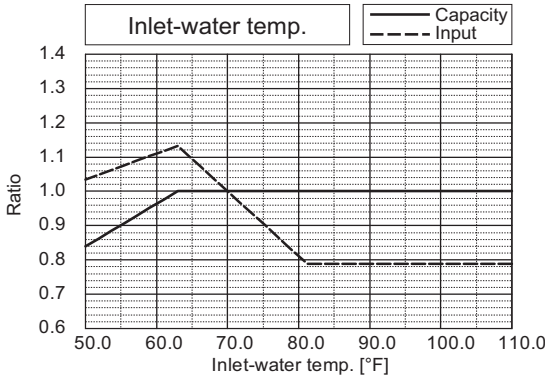

*The drawing indicates characteristic per unit.

WY 575V

6. CAPACITY TABLES

PQHY-			P192ZSKMU		
Nominal Cooling Capacity	kW	56.3	Rated Cooling Capacity	kW	53.6
	BTU/h	192,000		BTU/h	183,000
Input	kW	12.60	Input	kW	(Non-Ducted) 10.28 (Ducted) 11.73

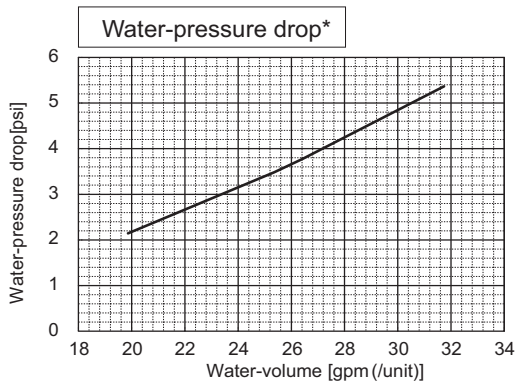
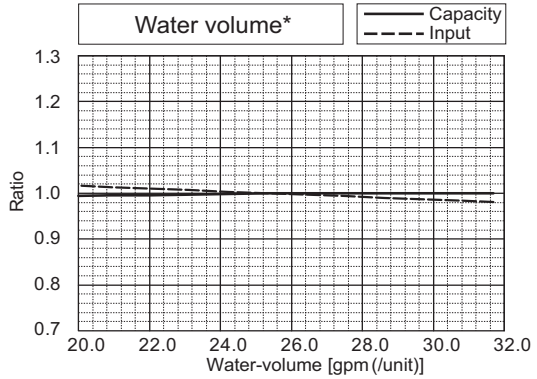
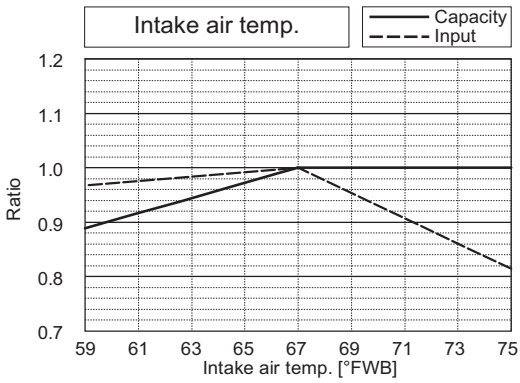
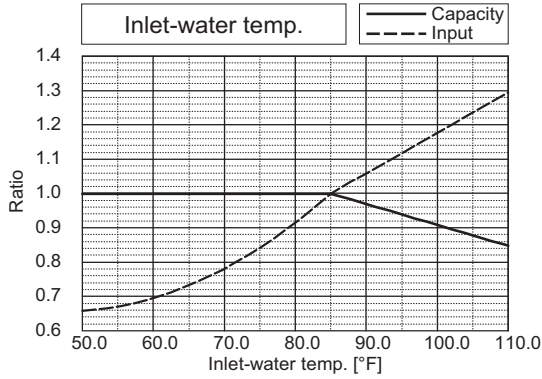

*The drawing indicates characteristic per unit.

PQHY-			P192ZSKMU		
Nominal Heating Capacity	kW	63.0	Rated Heating Capacity	kW	60.1
	BTU/h	215,000		BTU/h	205,000
Input	kW	13.01	Input	kW	(Non-Ducted) 11.19 (Ducted) 12.11

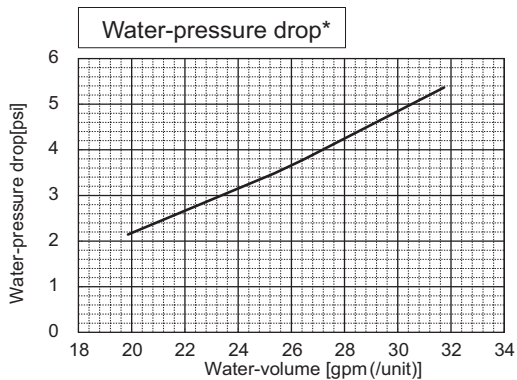
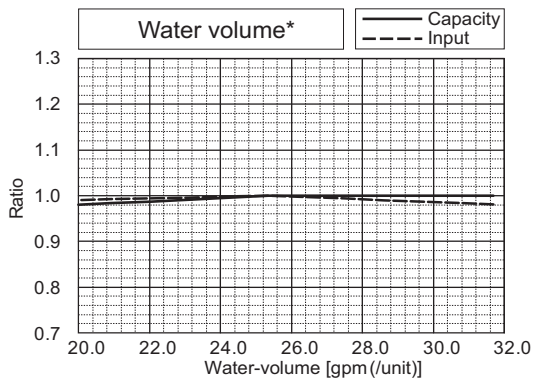
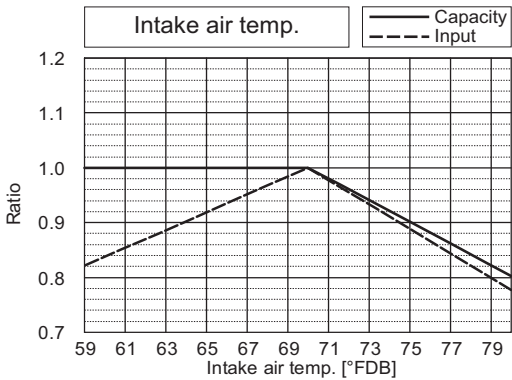
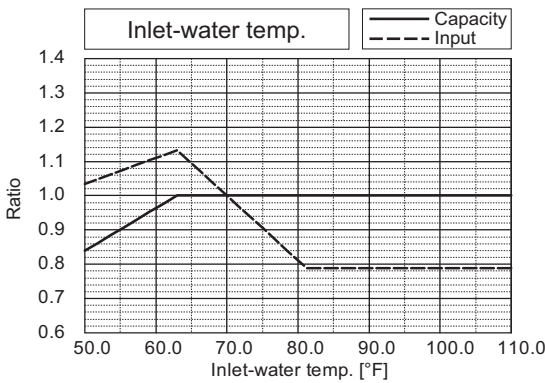

*The drawing indicates characteristic per unit.

WY 575V

6. CAPACITY TABLES

PQHY-		P216ZSKMU			
Nominal Cooling Capacity	kW	63.3	Rated Cooling Capacity	kW	60.4
	BTU/h	216,000		BTU/h	206,000
Input	kW	14.60	Input	kW	(Non-Ducted) 12.77 (Ducted) 13.59

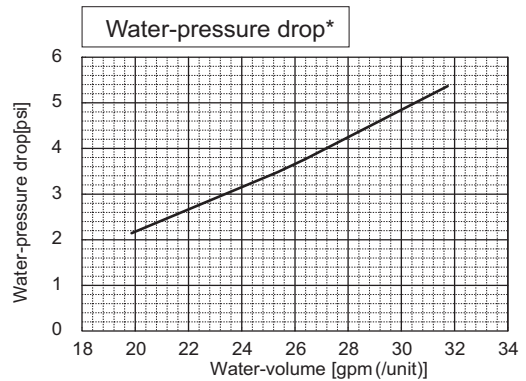
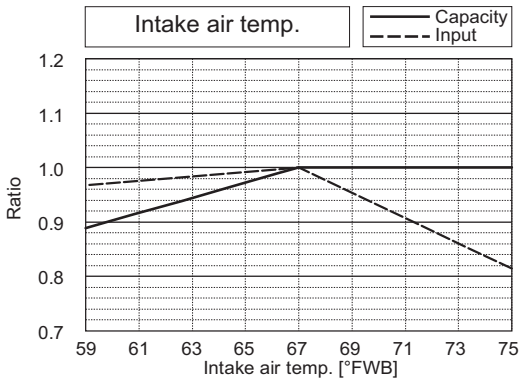
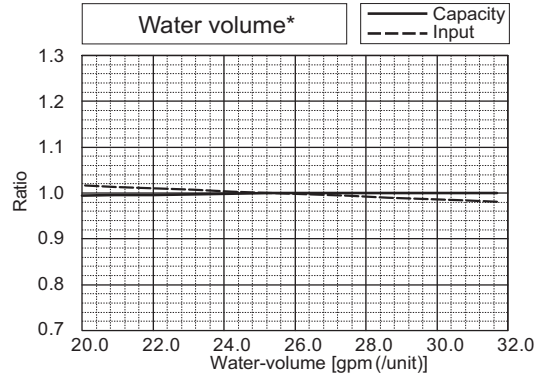
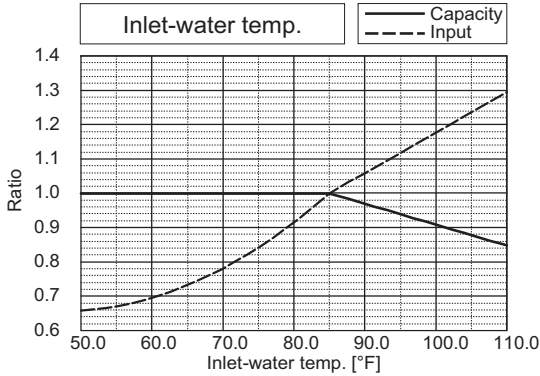

*The drawing indicates characteristic per unit.

PQHY-		P216ZSKMU			
Nominal Heating Capacity	kW	71.2	Rated Heating Capacity	kW	68.0
	BTU/h	243,000		BTU/h	232,000
Input	kW	14.97	Input	kW	(Non-Ducted) 13.88 (Ducted) 13.93

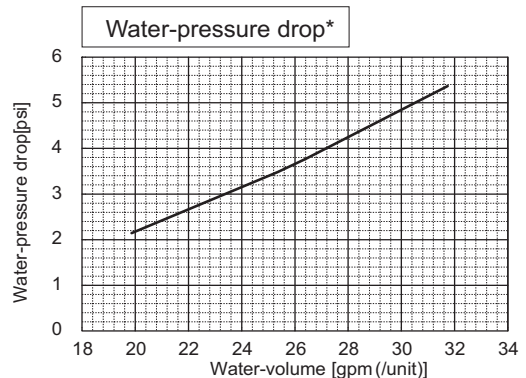
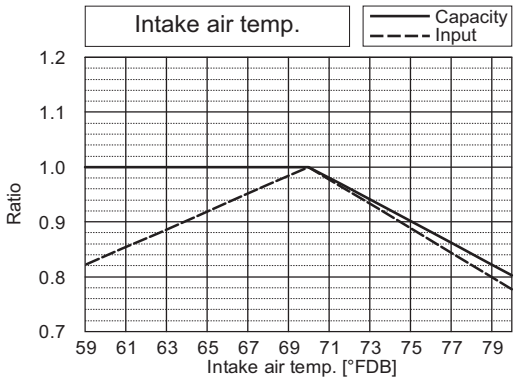
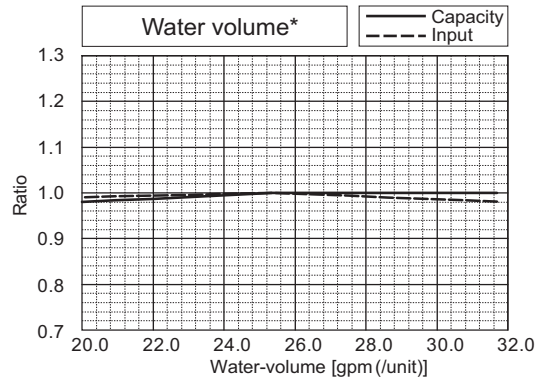
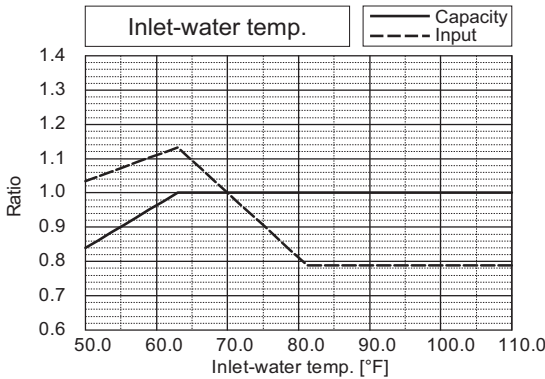

*The drawing indicates characteristic per unit.

6. CAPACITY TABLES

PQHY-			P240ZSKMU		
Nominal Cooling Capacity	kW	70.3	Rated Cooling Capacity	kW	66.8
	BTU/h	240,000		BTU/h	228,000
Input	kW	18.17	Input	kW	(Non-Ducted) 15.63 (Ducted) 16.91

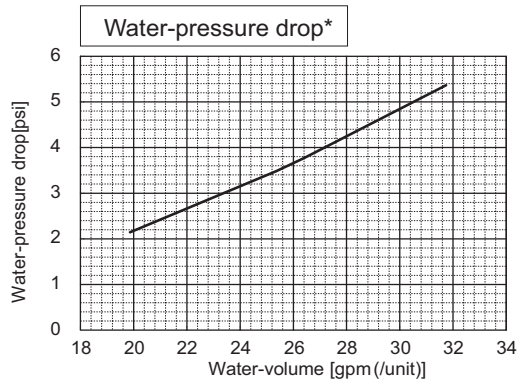
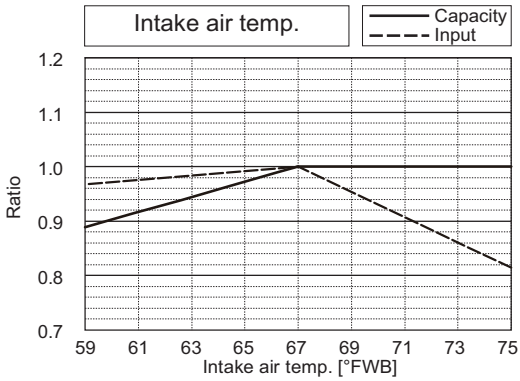
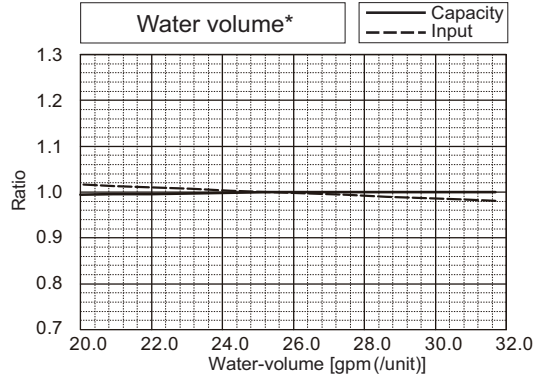
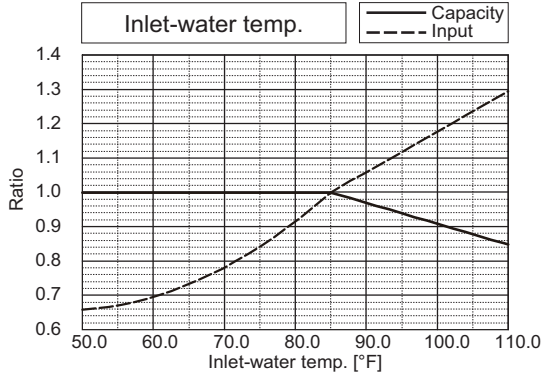

*The drawing indicates characteristic per unit.

PQHY-			P240ZSKMU		
Nominal Heating Capacity	kW	79.1	Rated Heating Capacity	kW	75.6
	BTU/h	270,000		BTU/h	258,000
Input	kW	17.14	Input	kW	(Non-Ducted) 16.78 (Ducted) 15.95

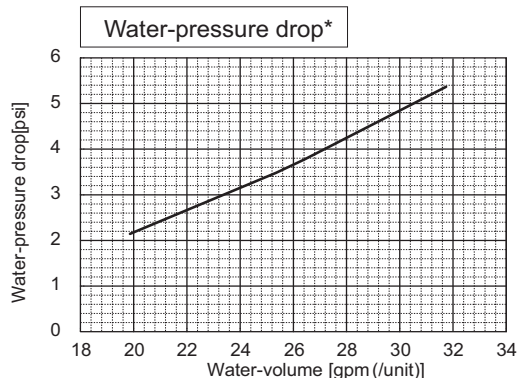
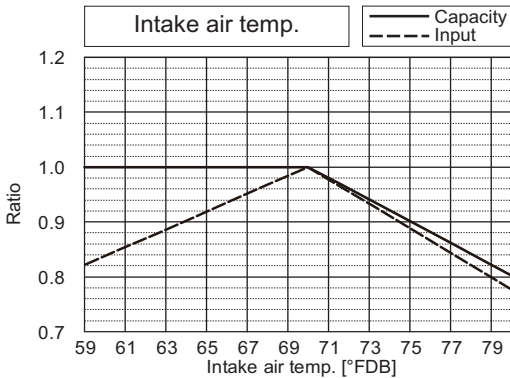
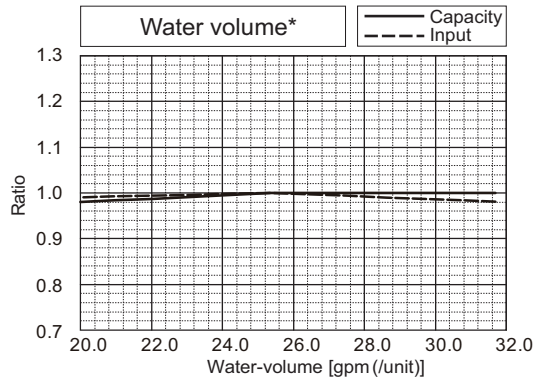
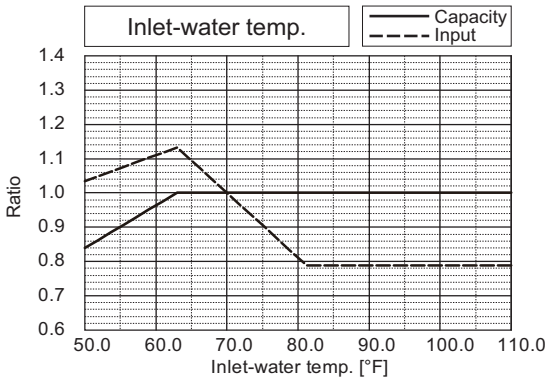

*The drawing indicates characteristic per unit.

WY 575V

PQHY-		P264ZSKMU			
Nominal Cooling Capacity	kW	77.4	Rated Cooling Capacity	kW	73.9
	BTU/h	264,000		BTU/h	252,000
Input	kW	17.96	Input	kW	(Non-Ducted) 14.61 (Ducted) 16.71

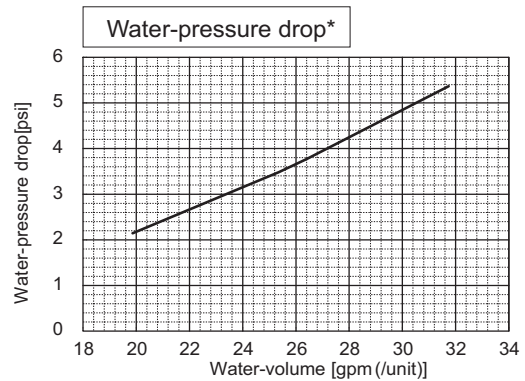
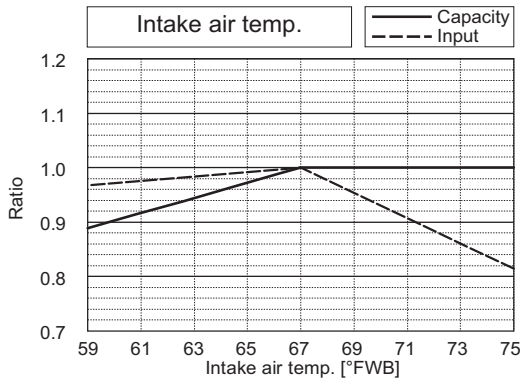
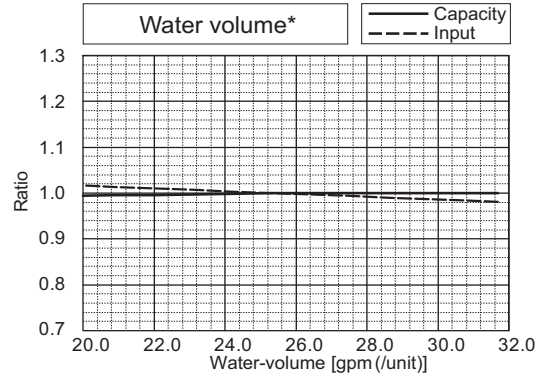
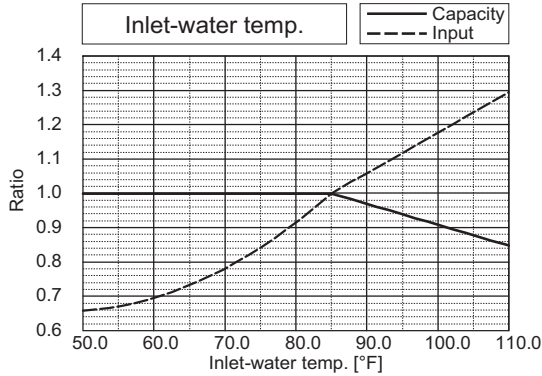

*The drawing indicates characteristic per unit.

PQHY-		P264ZSKMU			
Nominal Heating Capacity	kW	86.5	Rated Heating Capacity	kW	82.4
	BTU/h	295,000		BTU/h	281,000
Input	kW	17.27	Input	kW	(Non-Ducted) 15.52 (Ducted) 16.07

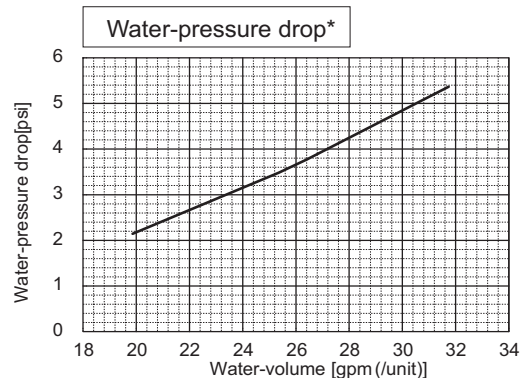
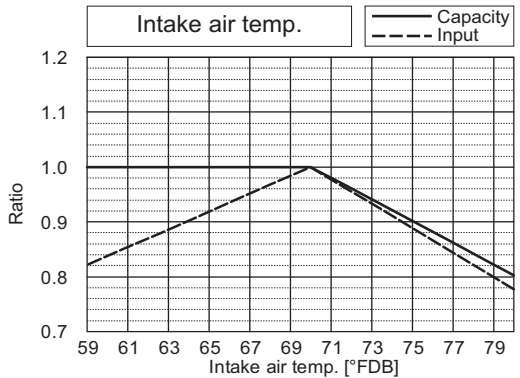
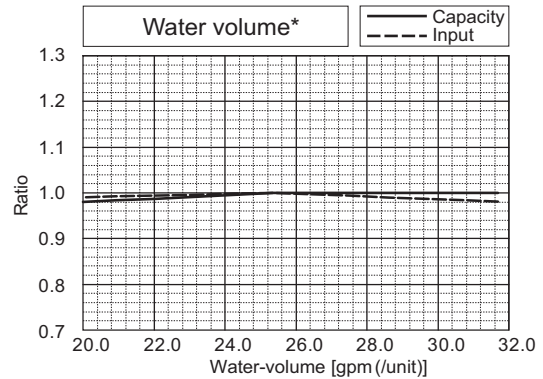
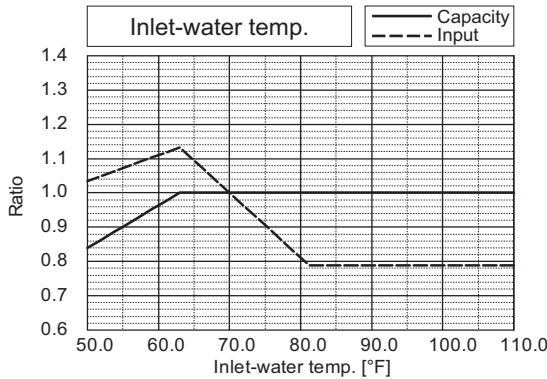

*The drawing indicates characteristic per unit.

WY 575V

6. CAPACITY TABLES

PQHY-			P288ZSKMU		
Nominal Cooling Capacity	kW	84.4	Rated Cooling Capacity	kW	80.6
	BTU/h	288,000		BTU/h	275,000
Input	kW	19.98	Input	kW	(Non-Ducted) 16.42 (Ducted) 18.59

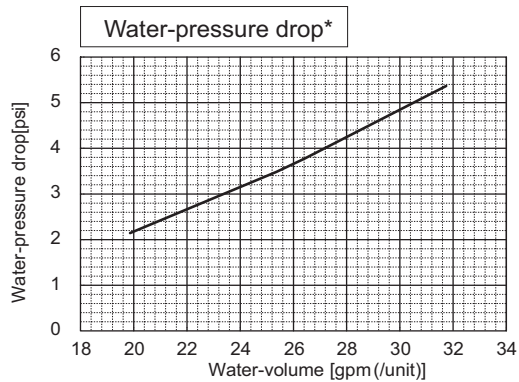
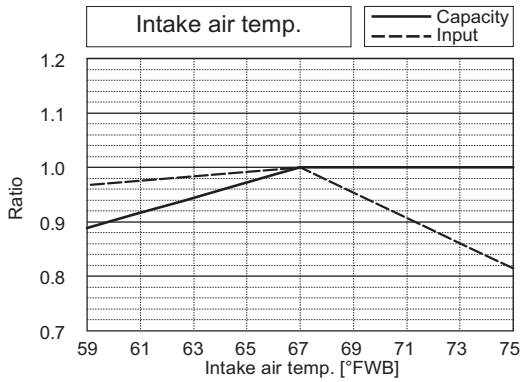
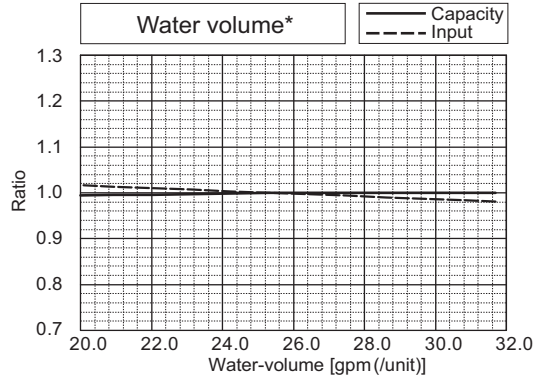
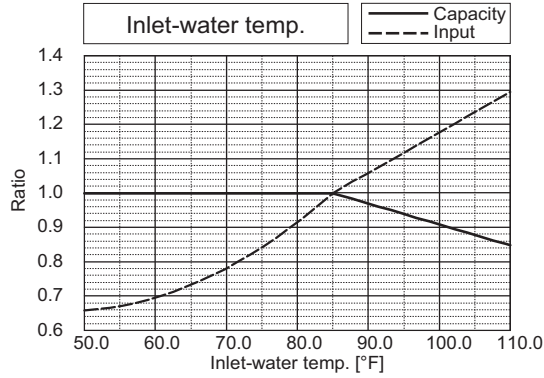

*The drawing indicates characteristic per unit.

PQHY-			P288ZSKMU		
Nominal Heating Capacity	kW	94.7	Rated Heating Capacity	kW	90.3
	BTU/h	323,000		BTU/h	308,000
Input	kW	19.55	Input	kW	(Non-Ducted) 17.31 (Ducted) 18.19

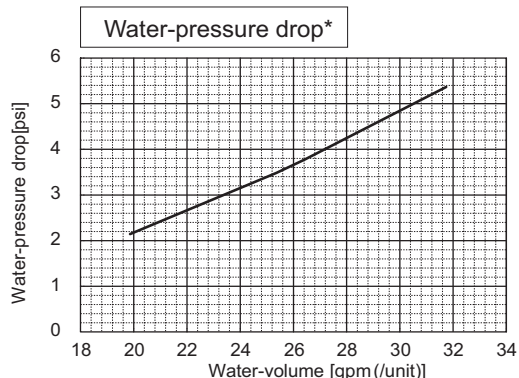
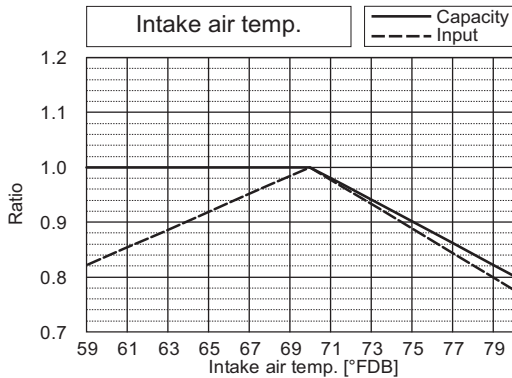
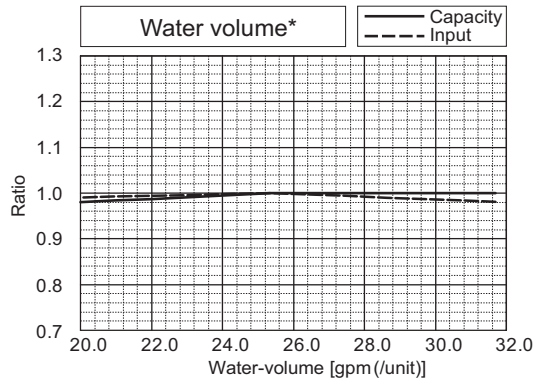
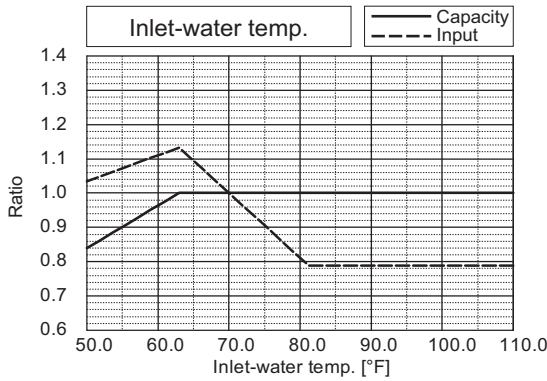

*The drawing indicates characteristic per unit.

WY 575V

6. CAPACITY TABLES

PQHY-			P312ZSKMU		
Nominal Cooling Capacity	kW	91.4	Rated Cooling Capacity	kW	87.0
	BTU/h	312,000		BTU/h	297,000
Input	kW	22.41	Input	kW	(Non-Ducted) 19.28 (Ducted) 20.85

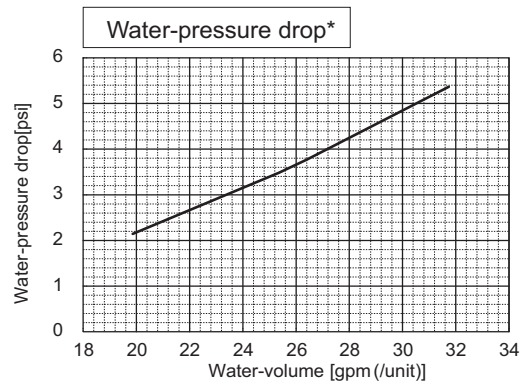
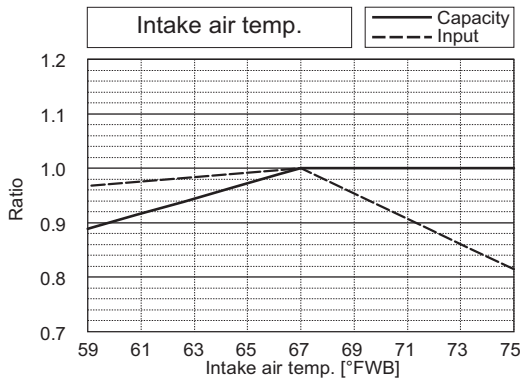
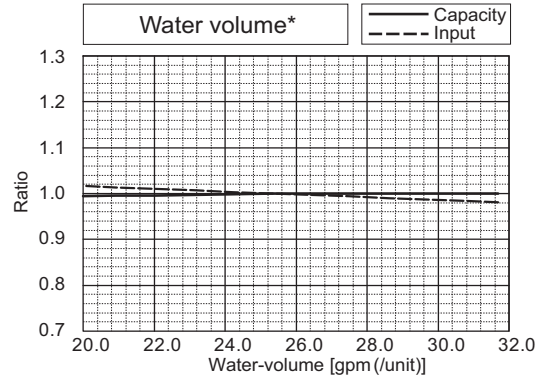
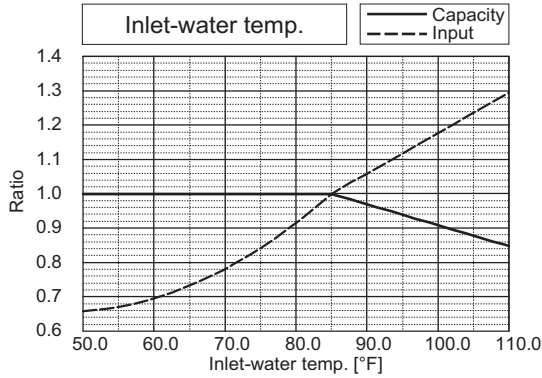

*The drawing indicates characteristic per unit.

PQHY-			P312ZSKMU		
Nominal Heating Capacity	kW	102.6	Rated Heating Capacity	kW	97.9
	BTU/h	350,000		BTU/h	334,000
Input	kW	21.52	Input	kW	(Non-Ducted) 20.10 (Ducted) 20.02

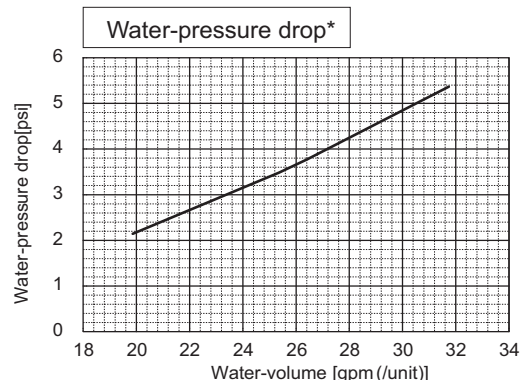
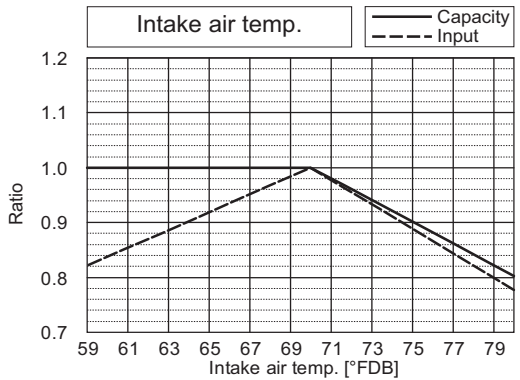
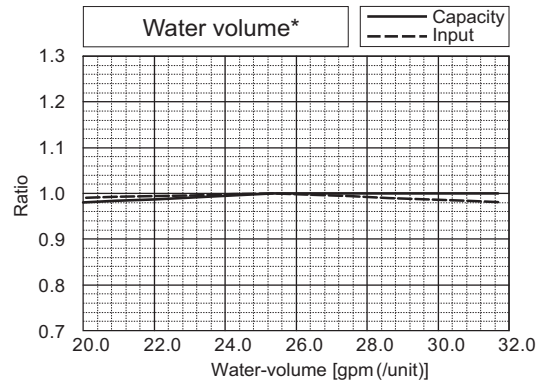
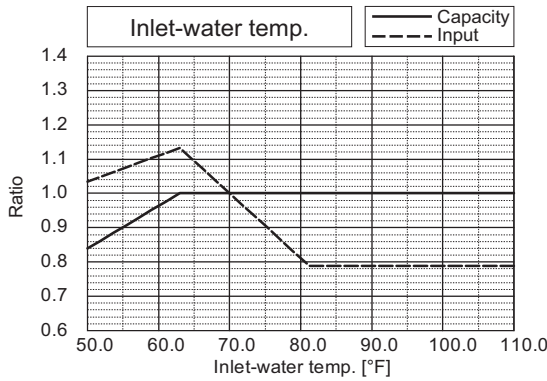

*The drawing indicates characteristic per unit.

WY 575V

6. CAPACITY TABLES

PQHY-			P336ZSKMU		
Nominal Cooling Capacity	kW	98.5	Rated Cooling Capacity	kW	93.8
	BTU/h	336,000		BTU/h	320,000
Input	kW	24.86	Input	kW	(Non-Ducted) 22.51 (Ducted) 23.13

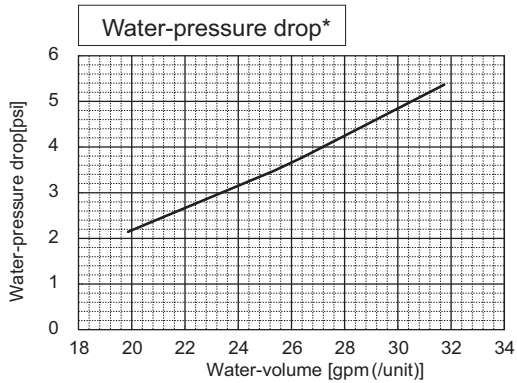
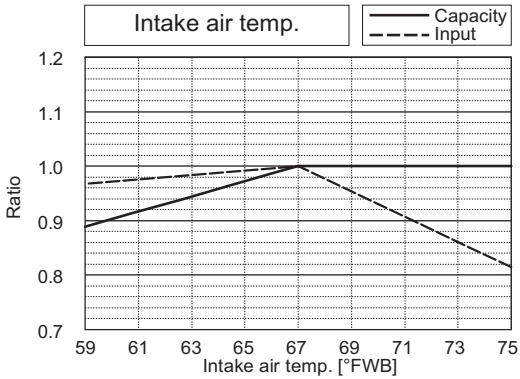
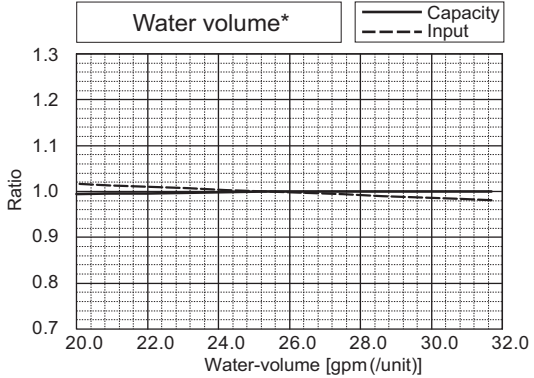
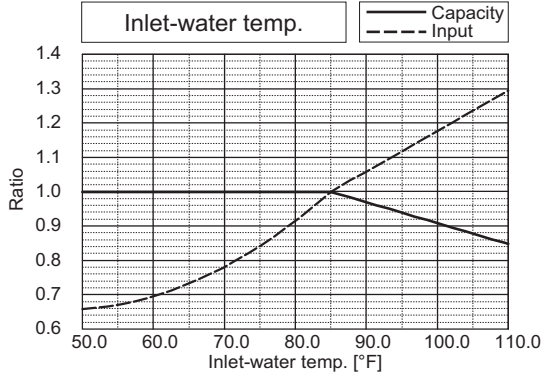

*The drawing indicates characteristic per unit.

PQHY-			P336ZSKMU		
Nominal Heating Capacity	kW	110.8	Rated Heating Capacity	kW	105.8
	BTU/h	378,000		BTU/h	361,000
Input	kW	23.68	Input	kW	(Non-Ducted) 23.32 (Ducted) 22.03

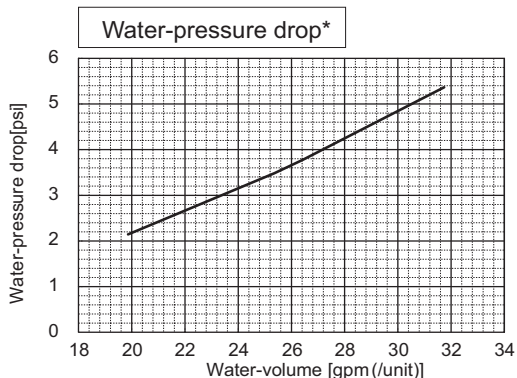
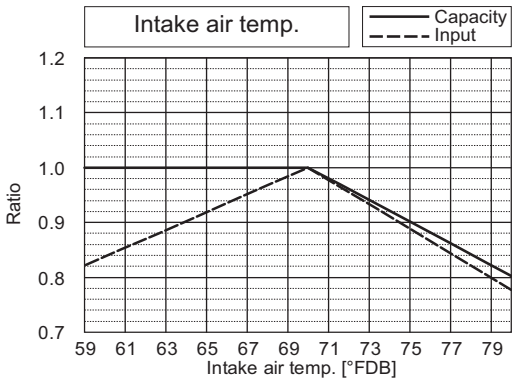
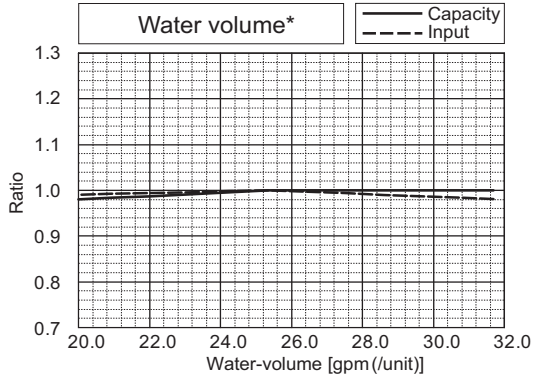
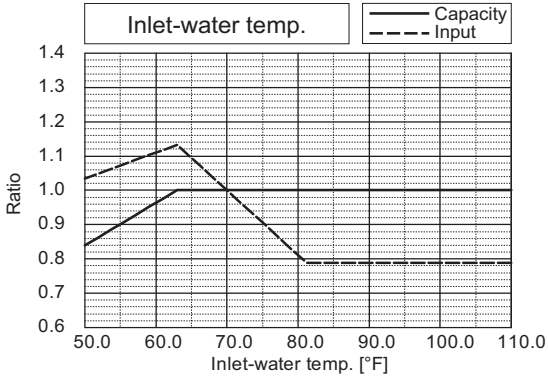

*The drawing indicates characteristic per unit.

WY 575V

6. CAPACITY TABLES

PQHY-		P360ZSKMU			
Nominal Cooling Capacity	kW	105.5	Rated Cooling Capacity	kW	100.2
	BTU/h	360,000		BTU/h	342,000
Input	kW	27.35	Input	kW	(Non-Ducted) 26.39 (Ducted) 25.45

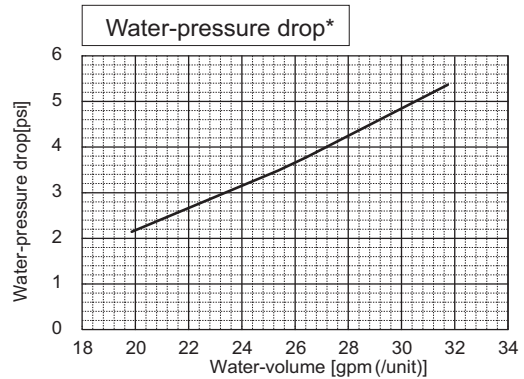
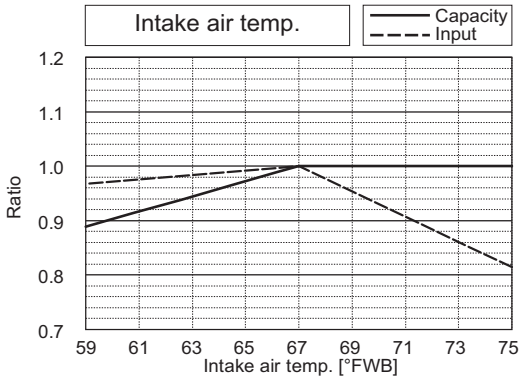
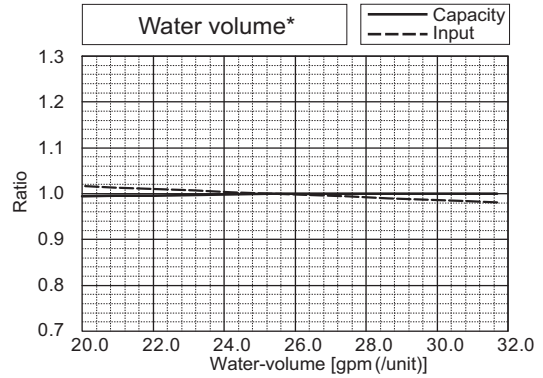
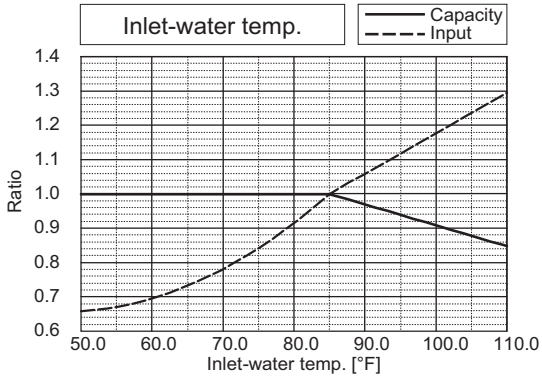

*The drawing indicates characteristic per unit.

PQHY-		P360ZSKMU			
Nominal Heating Capacity	kW	118.7	Rated Heating Capacity	kW	113.4
	BTU/h	405,000		BTU/h	387,000
Input	kW	25.75	Input	kW	(Non-Ducted) 26.85 (Ducted) 23.96

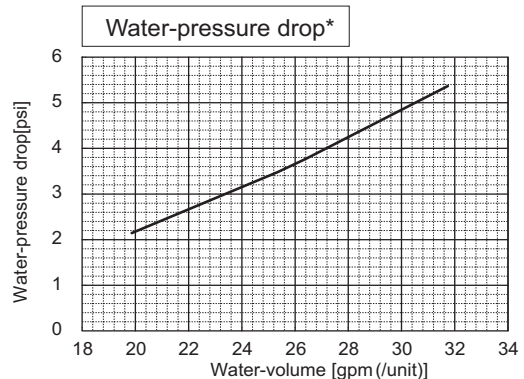
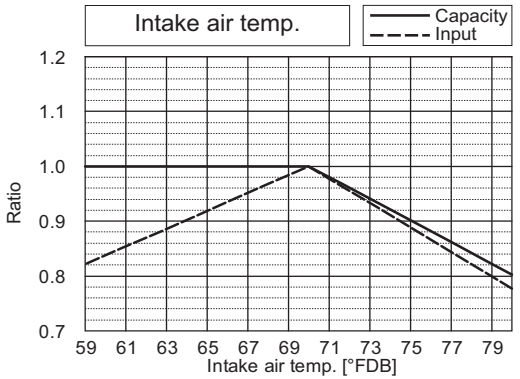
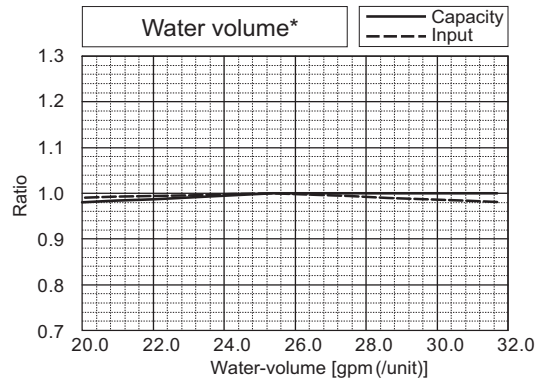
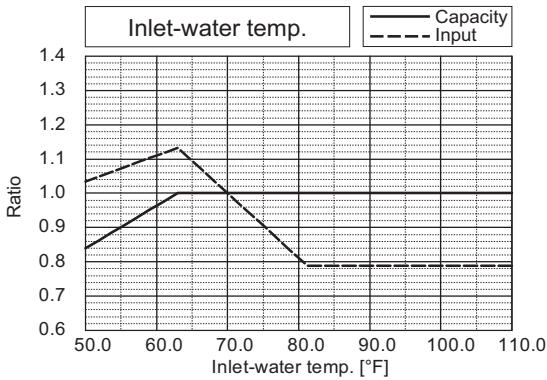

*The drawing indicates characteristic per unit.

WY 575V

6-2. Correction by total indoor

CITY MULTI system have different capacities and inputs when many combinations of indoor units with different total capacities are connected. Using following tables, the maximum capacity can be found to ensure the system is installed with enough capacity for a particular application.

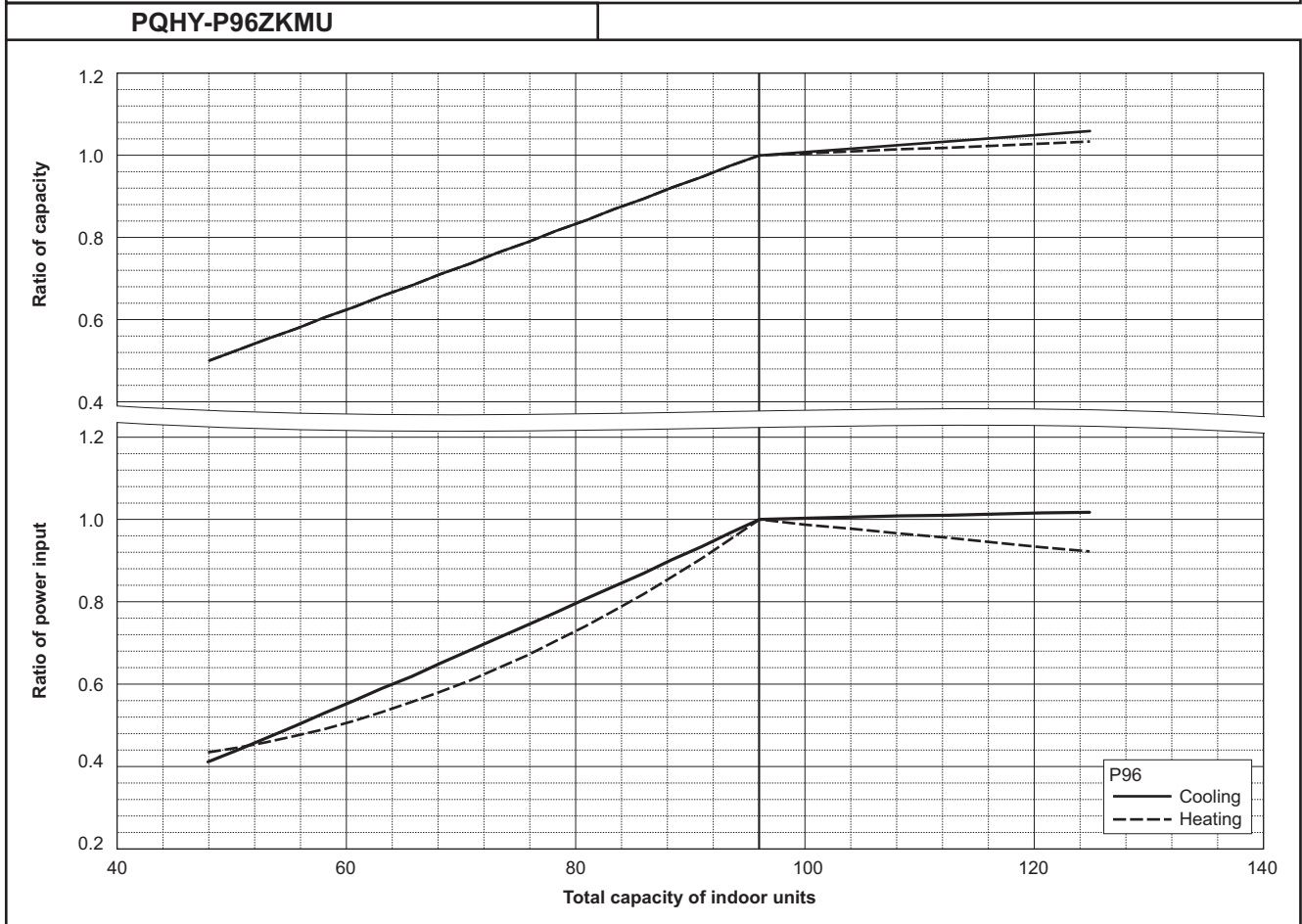
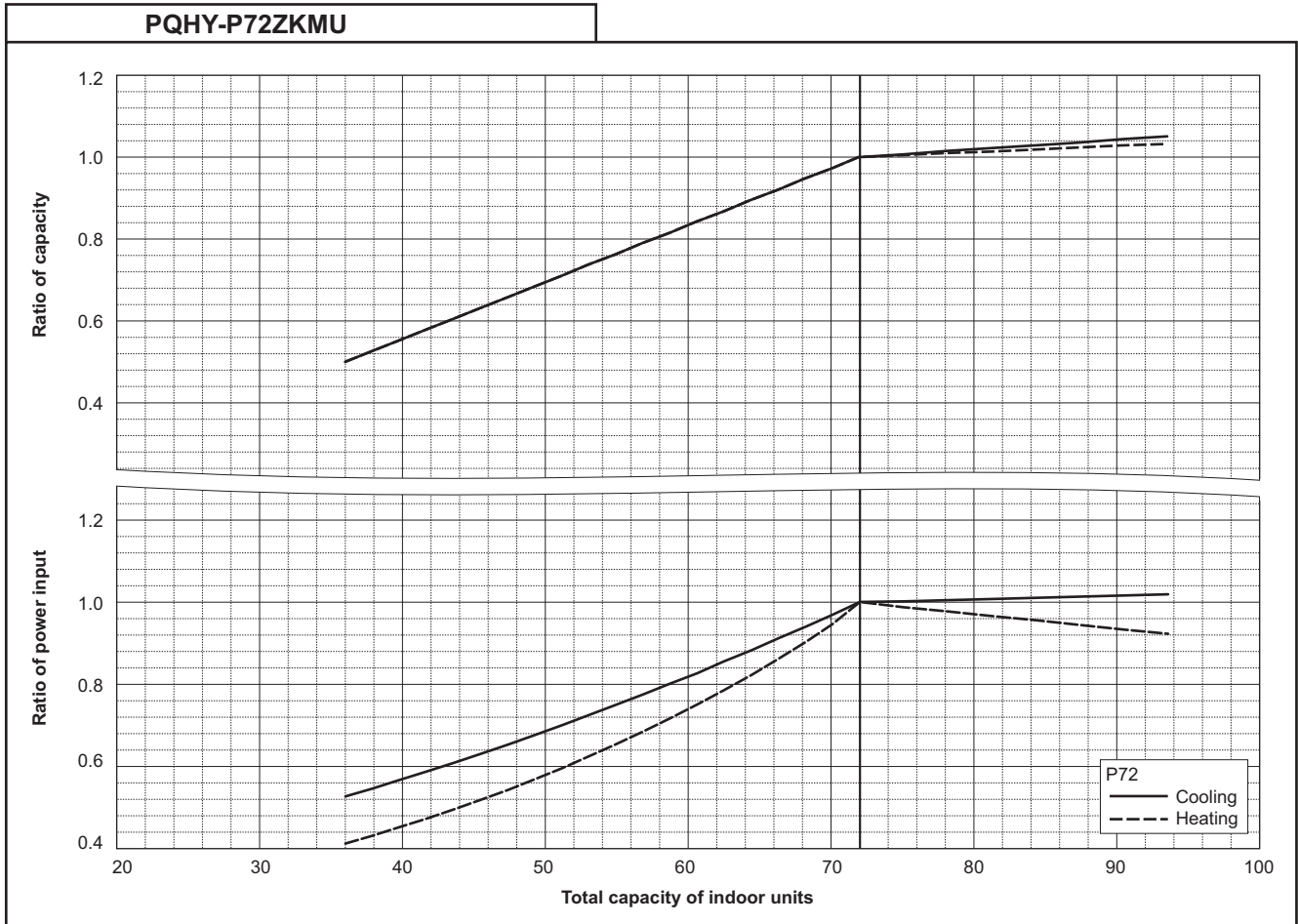

WY 575V

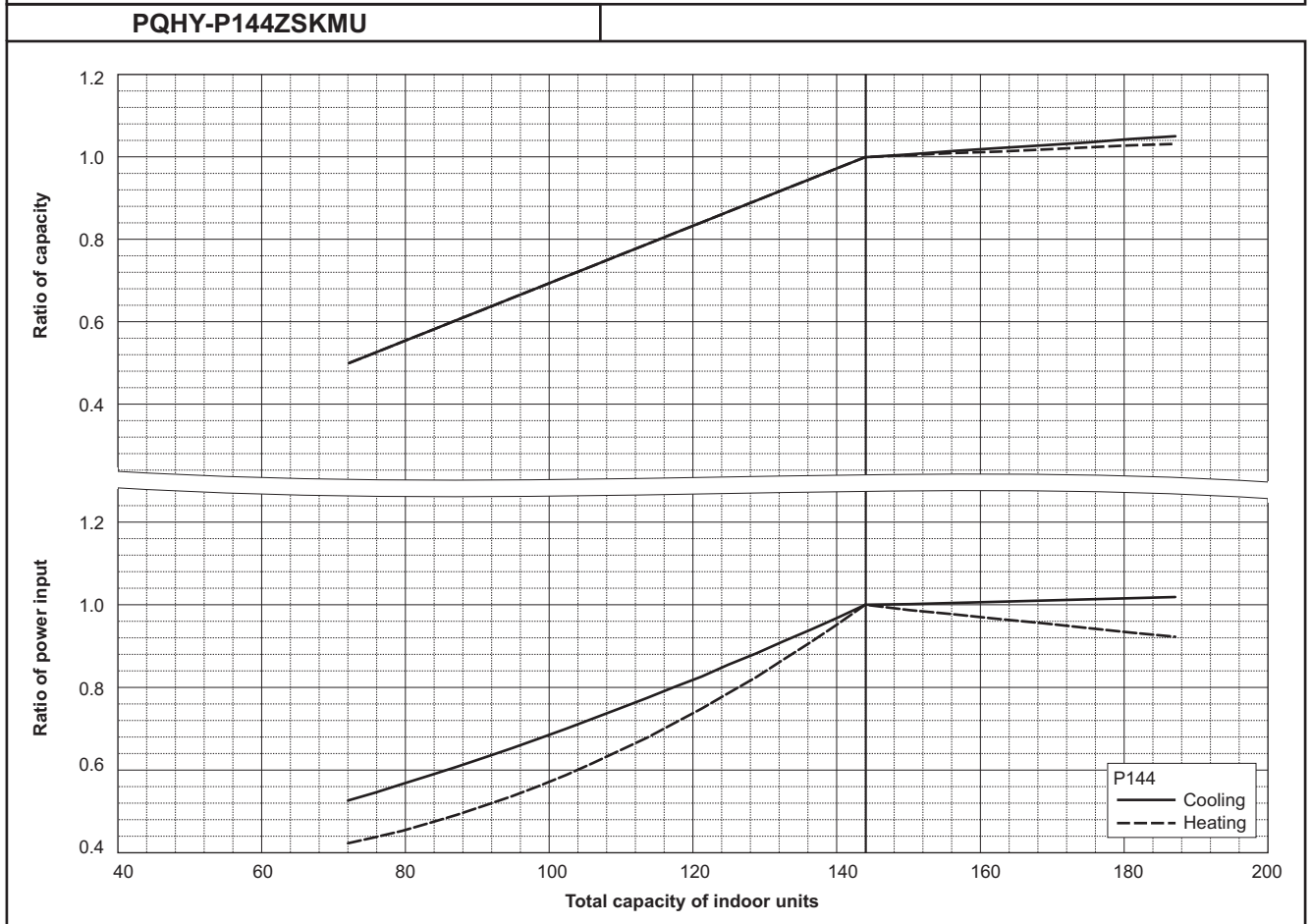
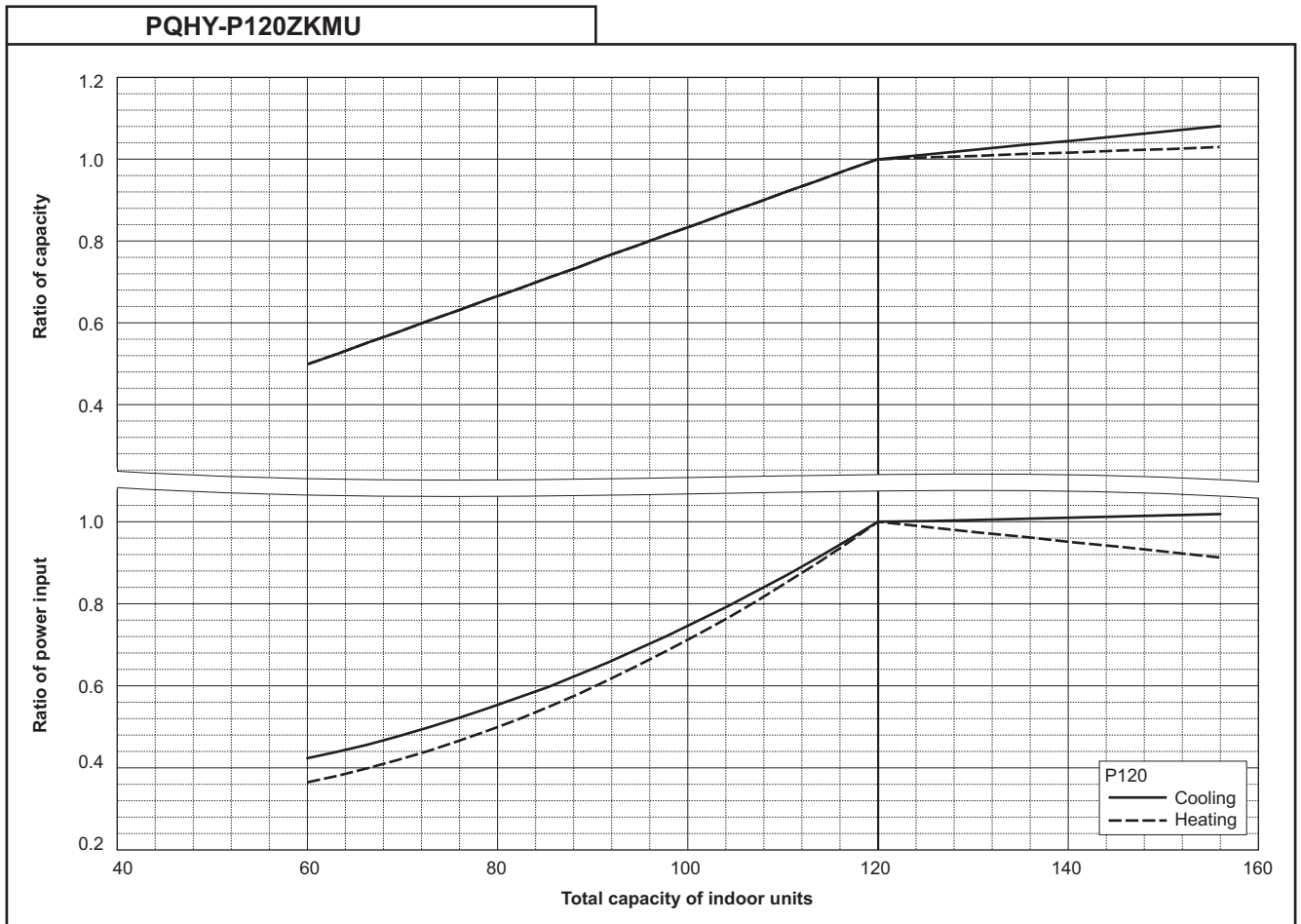

WY 575V

PQHY-P168ZSKMU

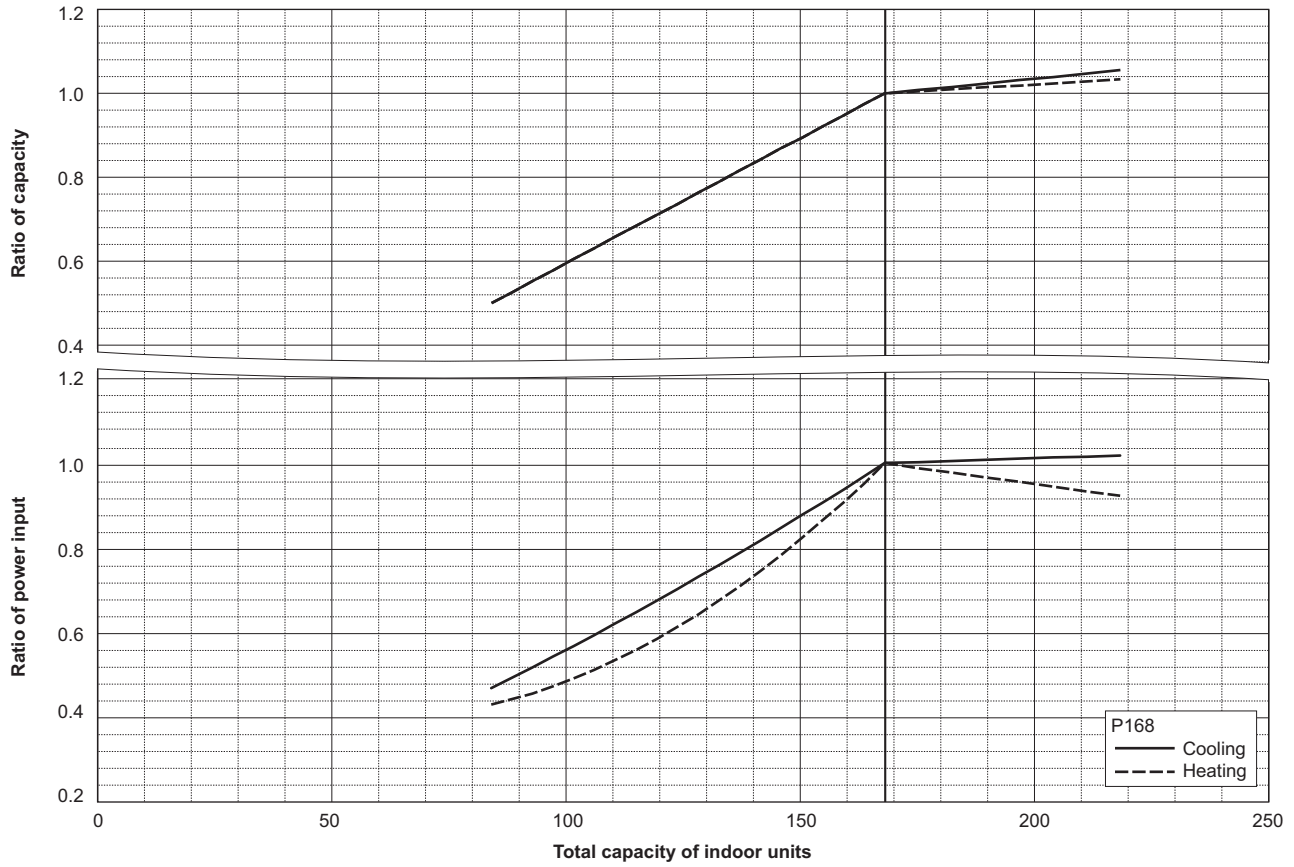

PQHY-P192ZSKMU

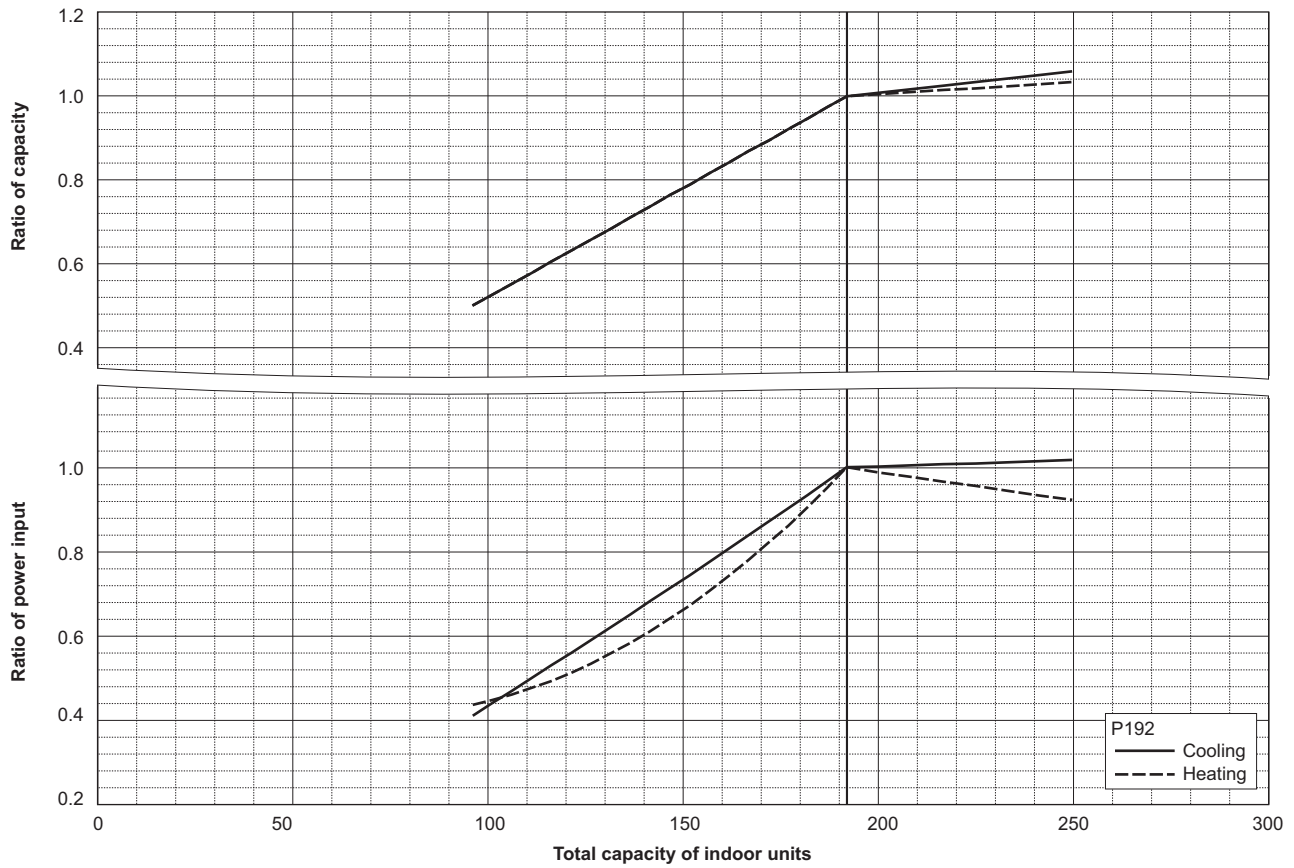

WY 575V

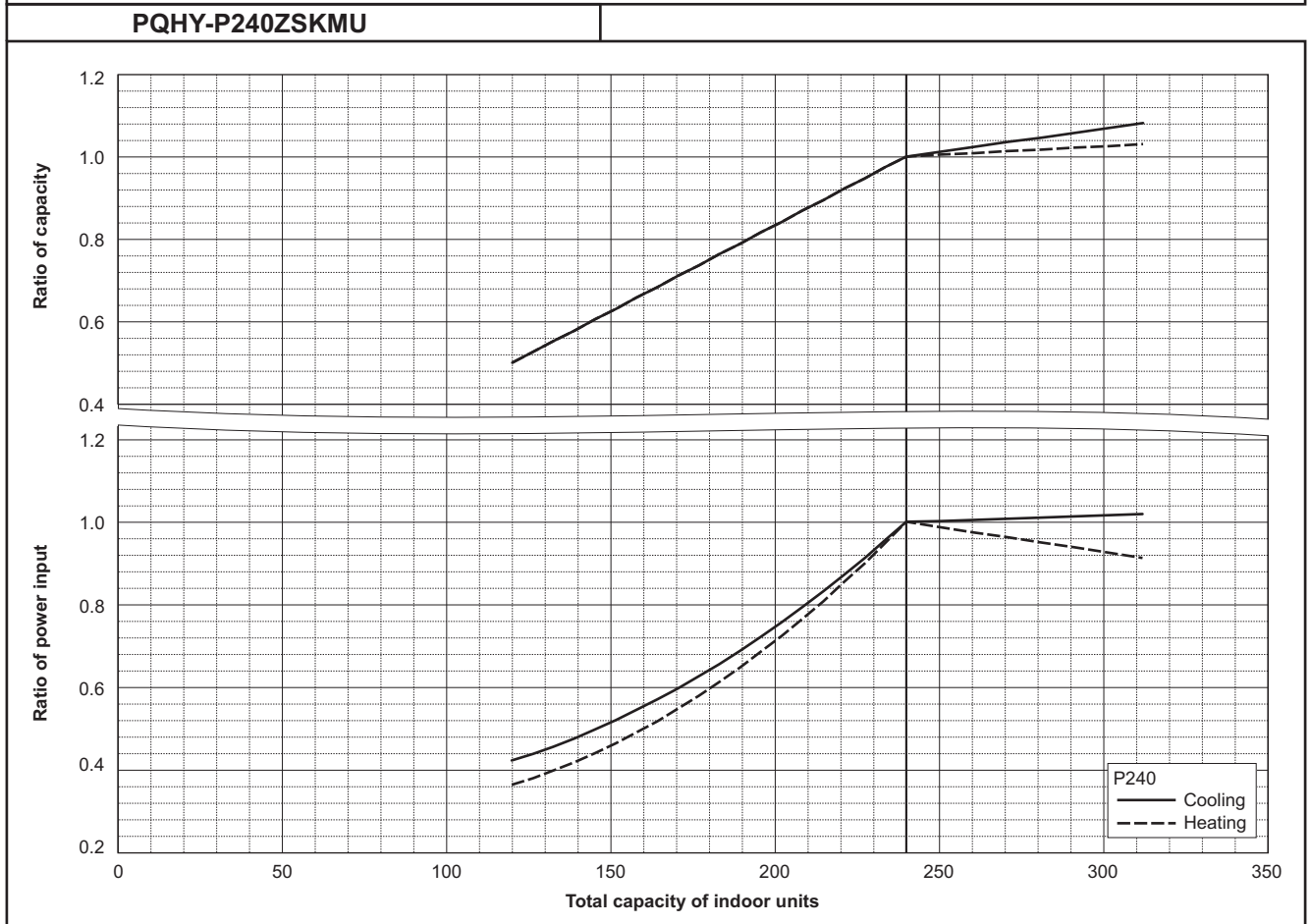
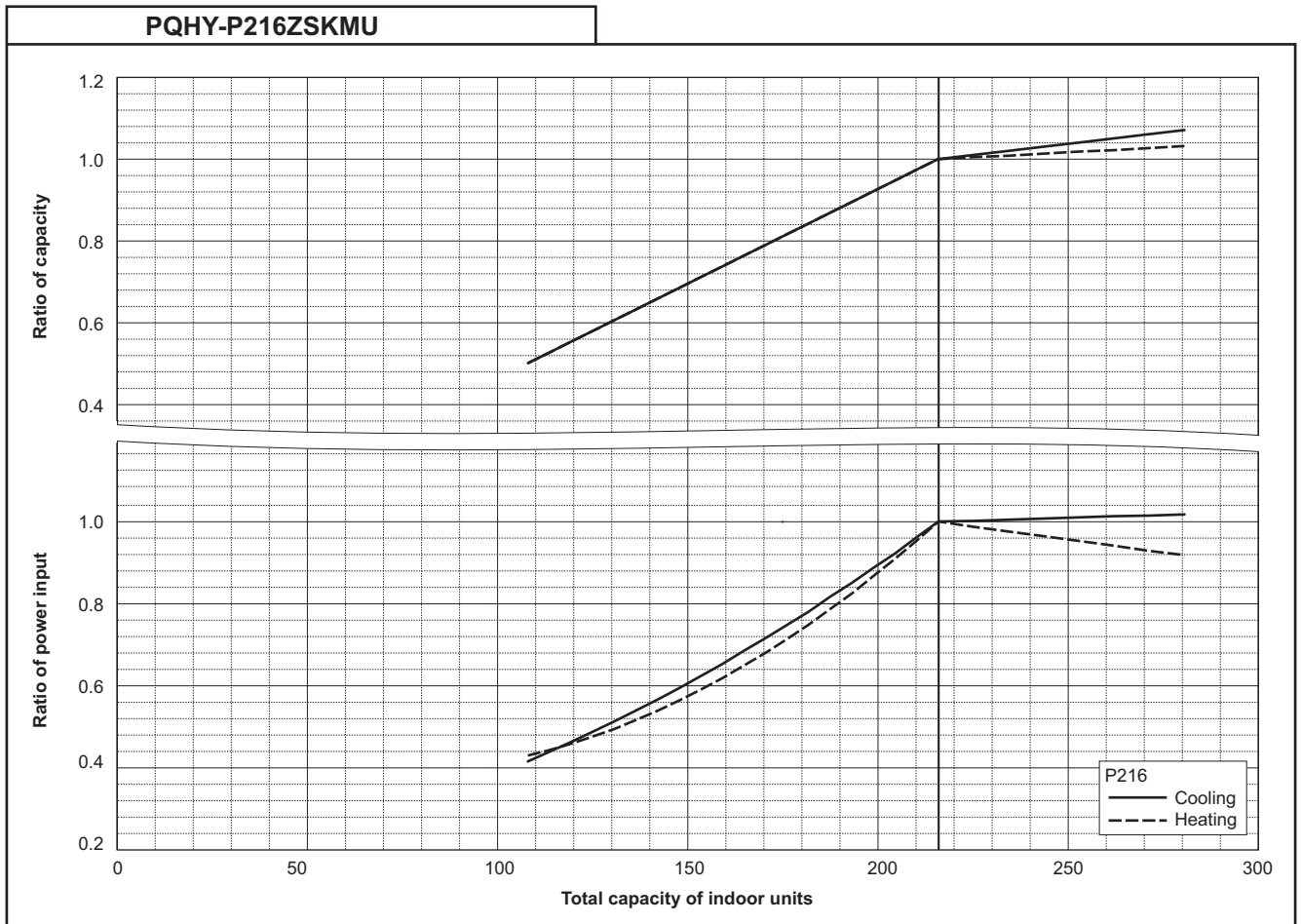

WY 575V

PQHY-P264ZSKMU

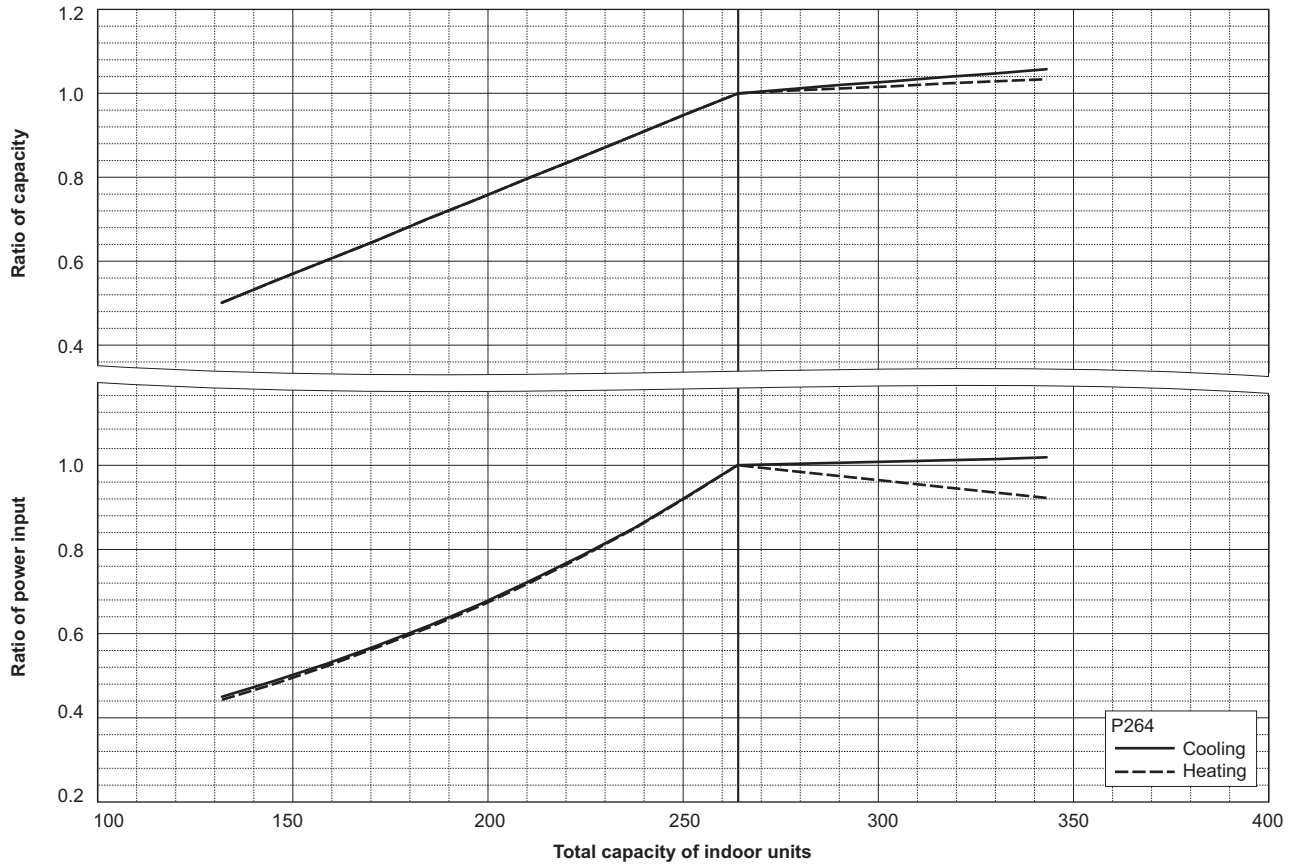

PQHY-P288ZSKMU

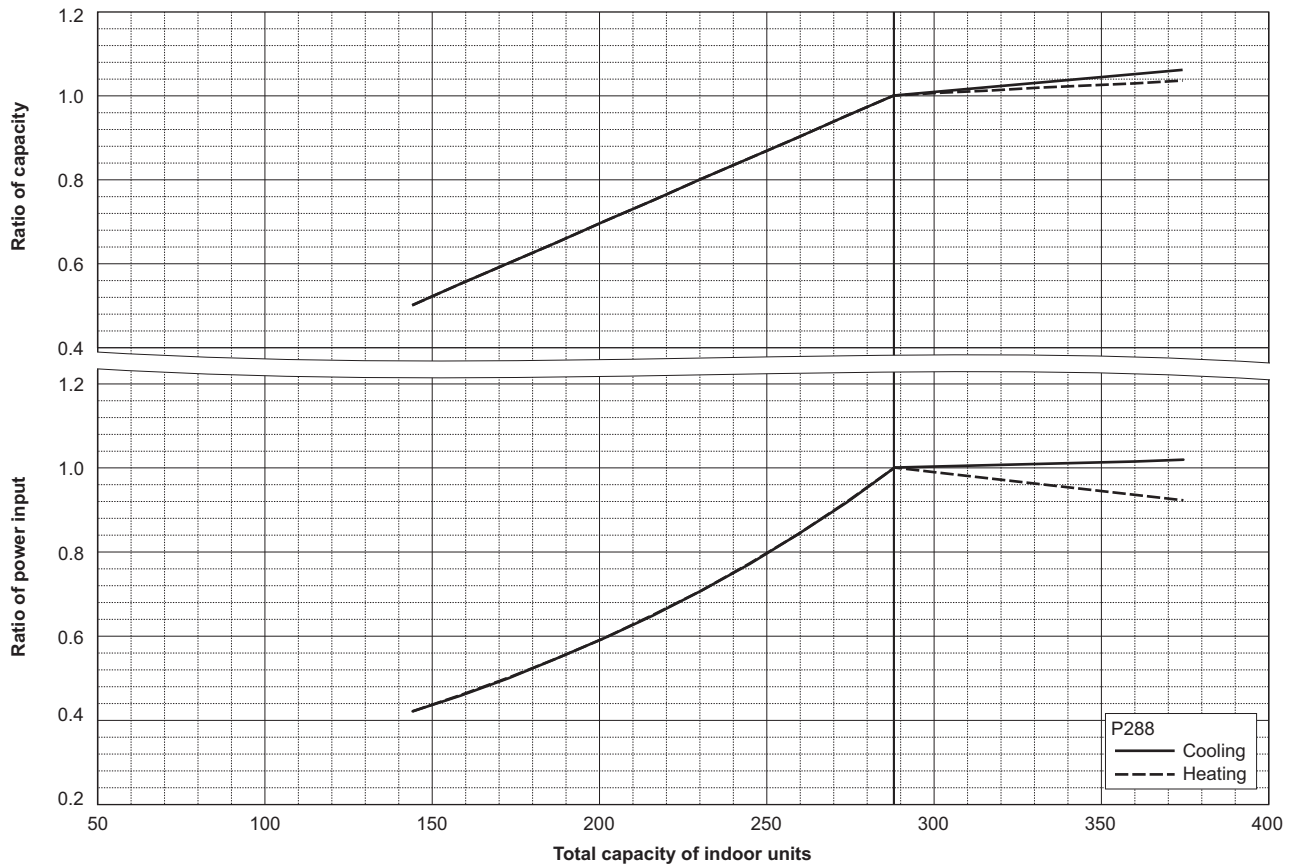

WY 575V

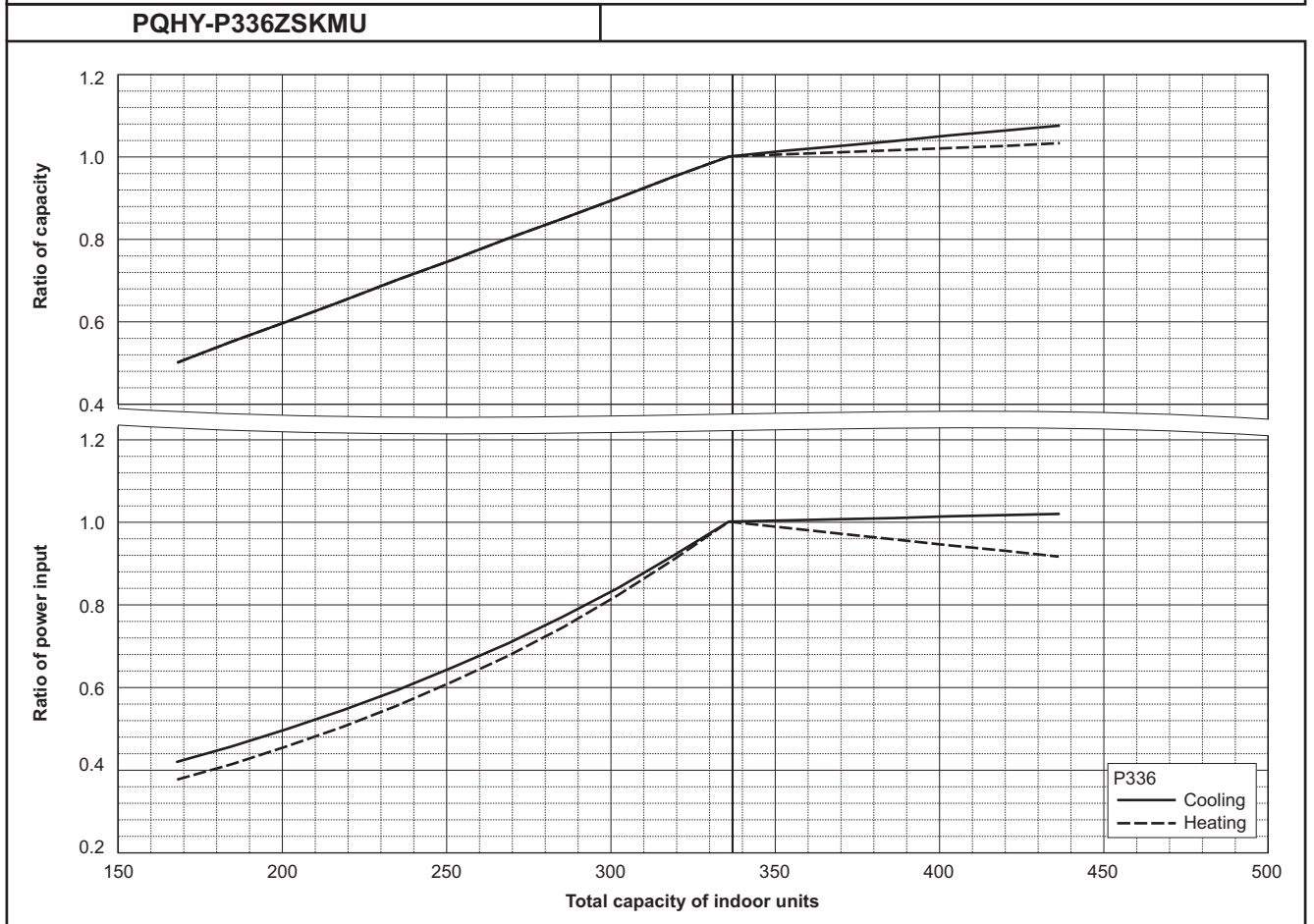
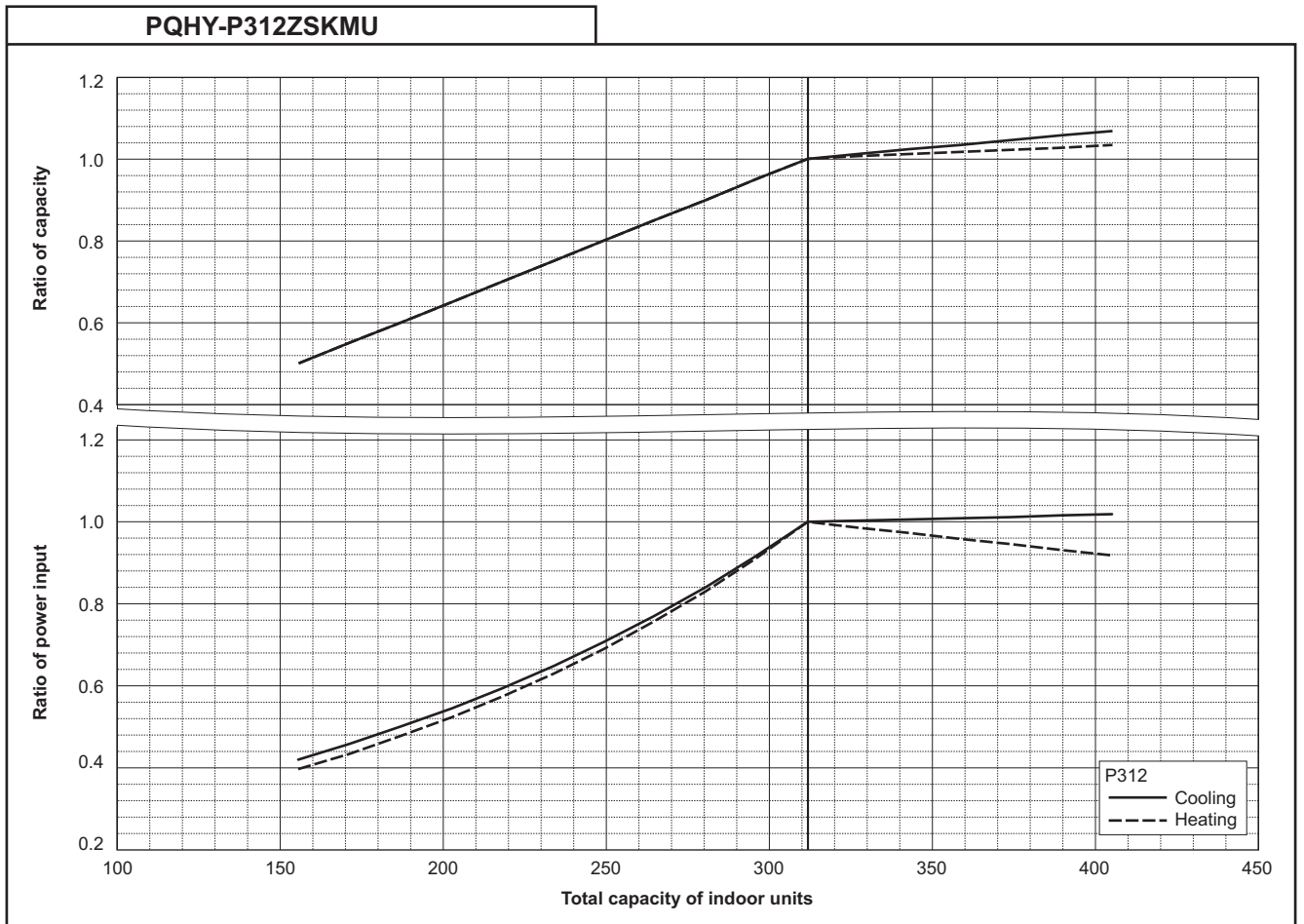

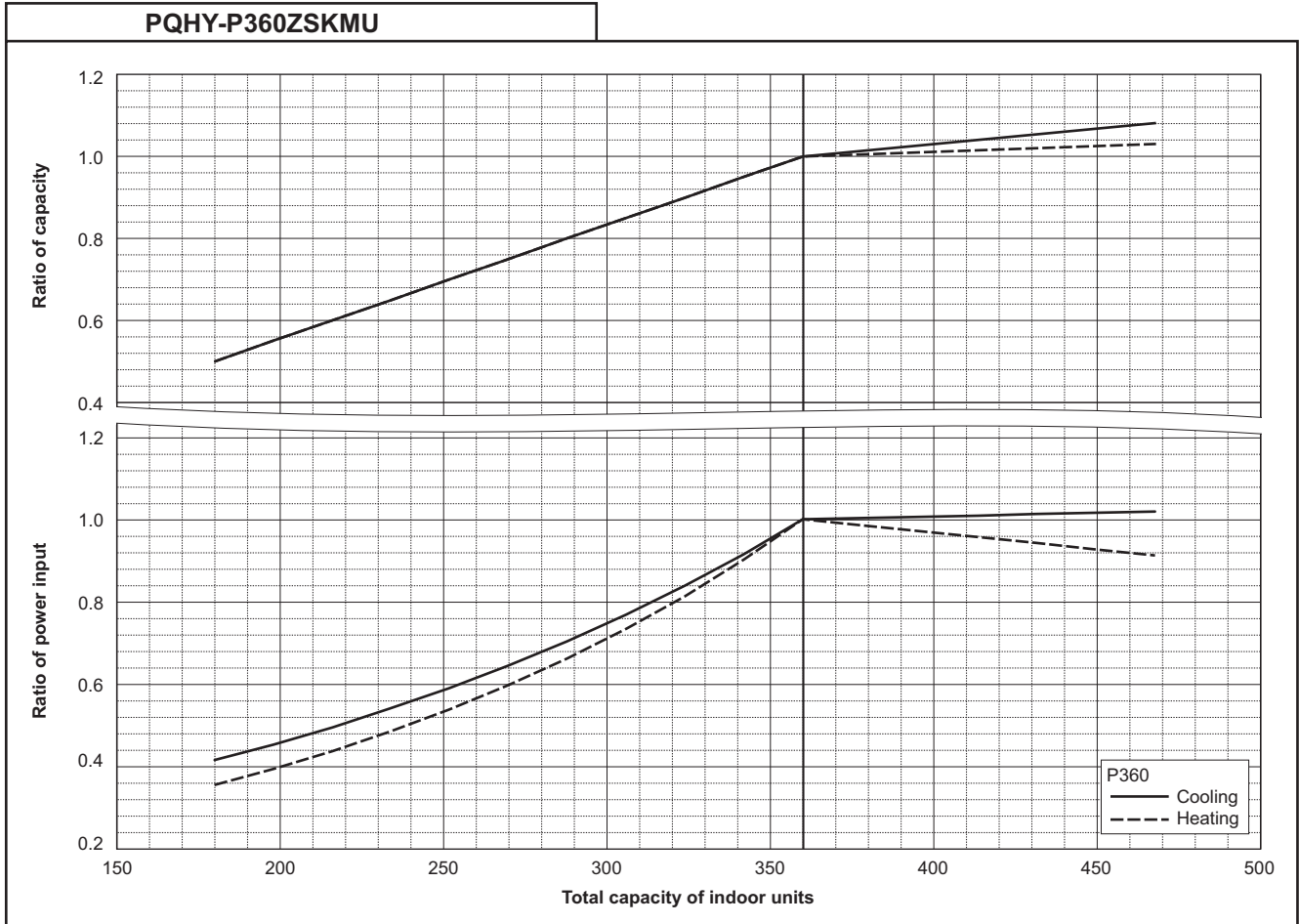

6-3. Correction by refrigerant piping length

CITY MULTI system can extend the piping flexibly within its limitation for the actual situation. However, a decrease of cooling/heating capacity could happen correspondently. Using following correction factor according to the equivalent length of the piping shown at 6-3-1 and 6-3-2, the capacity can be observed. 6-3-3 shows how to obtain the equivalent length of piping.

6-3-1. Cooling capacity correction

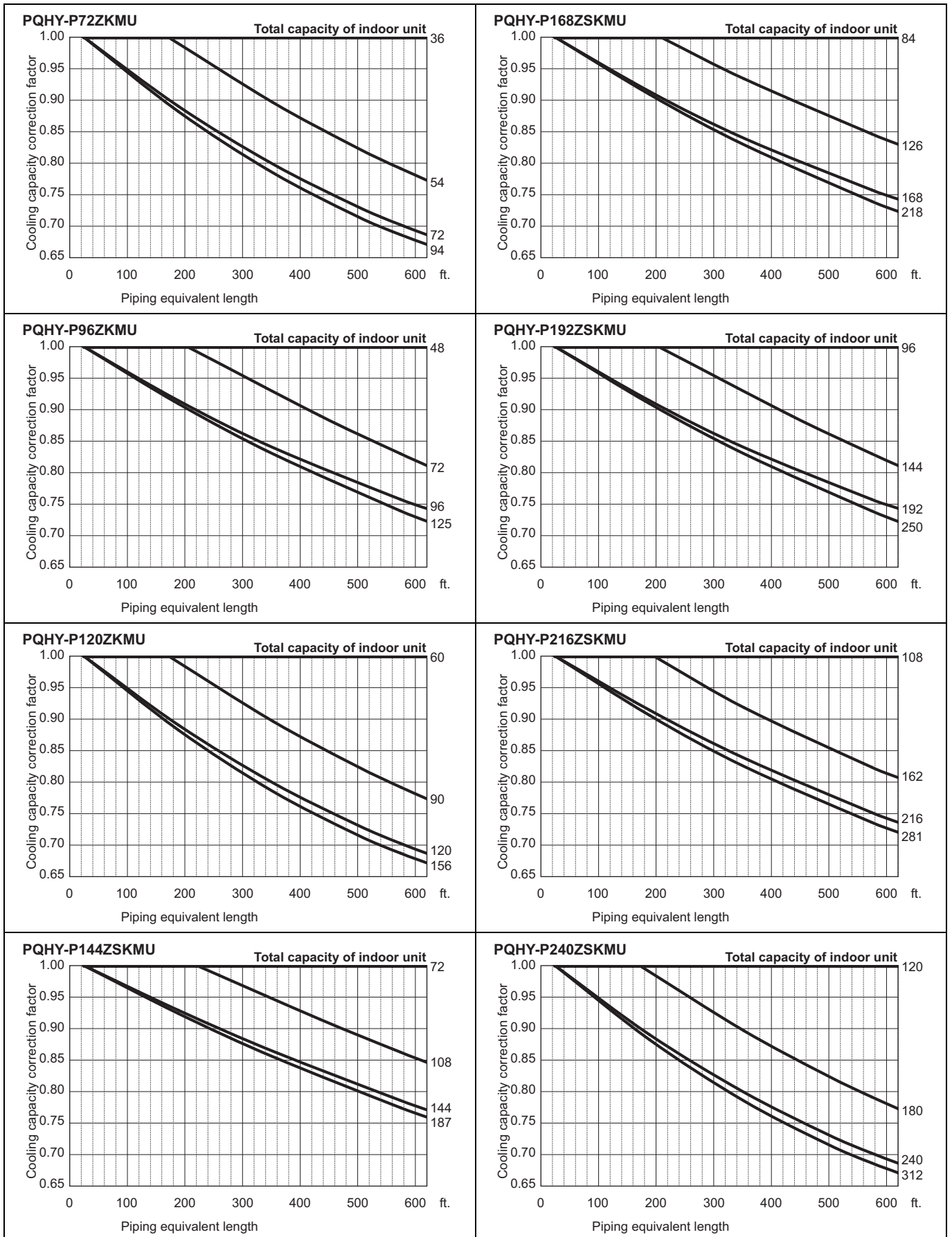

6. CAPACITY TABLES

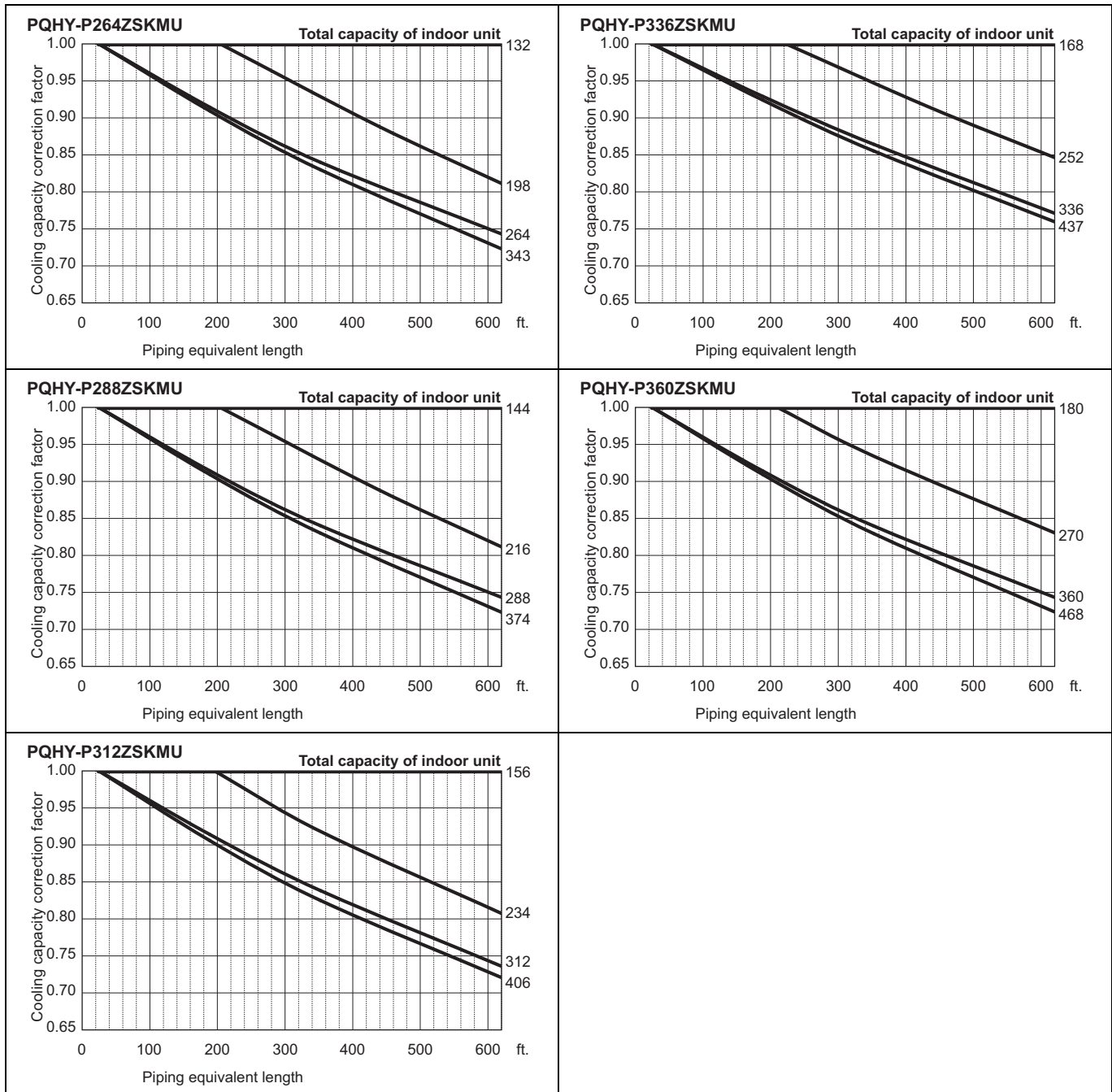

WY 575V

6-3-2. Heating capacity correction

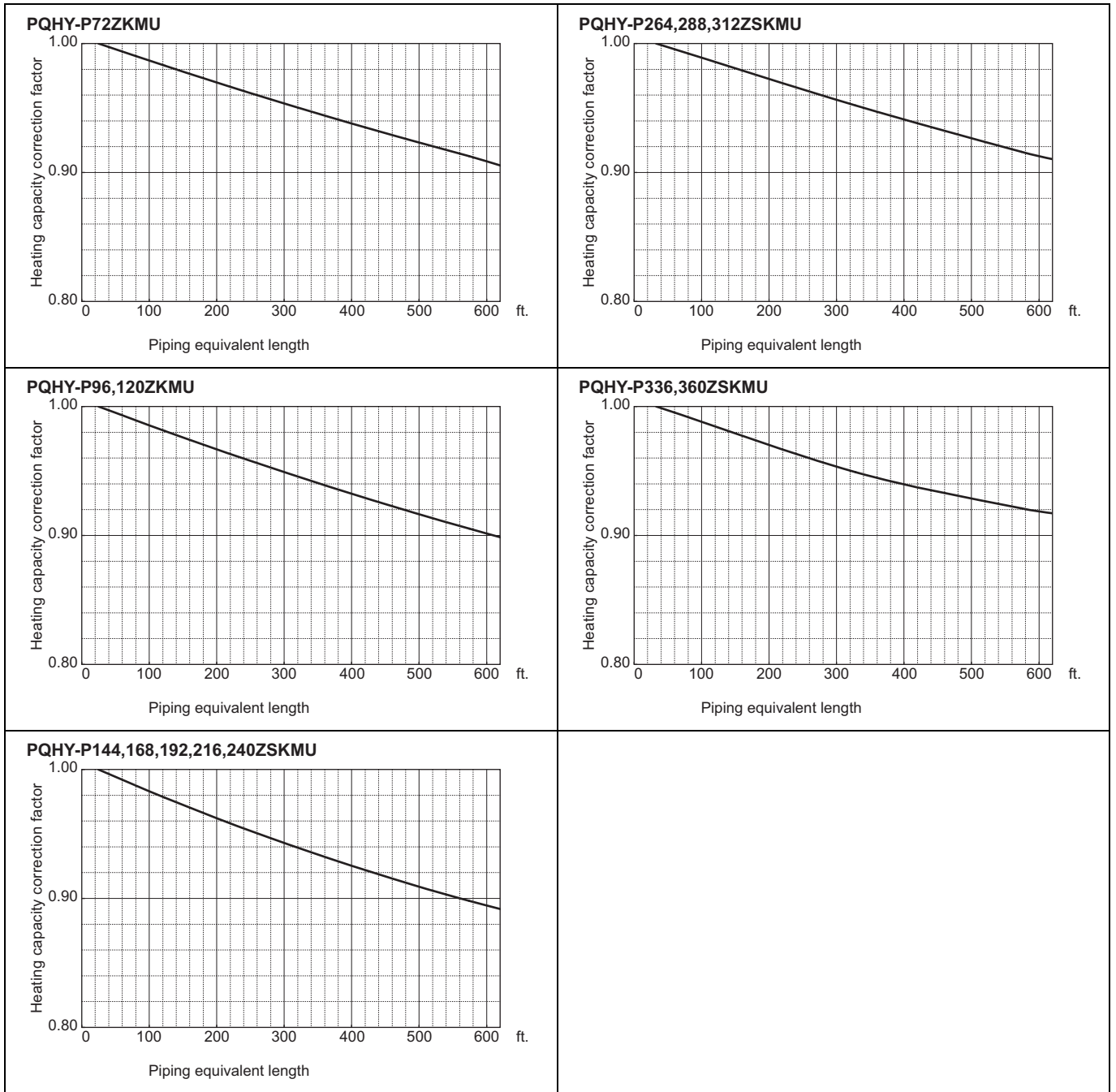

6-3-3. How to obtain the equivalent piping length

1. PQHY-P72ZKMU

Equivalent length = (Actual piping length to the farthest indoor unit) + (1.15 x number of bent on the piping) [ft.]
 Equivalent length = (Actual piping length to the farthest indoor unit) + (0.35 x number of bent on the piping) [m]

2. PQHY-P96, 120ZKMU

Equivalent length = (Actual piping length to the farthest indoor unit) + (1.38 x number of bent on the piping) [ft.]
 Equivalent length = (Actual piping length to the farthest indoor unit) + (0.42 x number of bent on the piping) [m]

3. PQHY-P144, 168, 192, 216, 240ZSKMU

Equivalent length = (Actual piping length to the farthest indoor unit) + (1.64 x number of bent on the piping) [ft.]
 Equivalent length = (Actual piping length to the farthest indoor unit) + (0.50 x number of bent on the piping) [m]

4. PQHY-P264, 288, 312ZSKMU

Equivalent length = (Actual piping length to the farthest indoor unit) + (2.30 x number of bent on the piping) [ft.]
 Equivalent length = (Actual piping length to the farthest indoor unit) + (0.70 x number of bent on the piping) [m]

5. PQHY-P336, 360ZSKMU

Equivalent length = (Actual piping length to the farthest indoor unit) + (2.63 x number of bent on the piping) [ft.]
 Equivalent length = (Actual piping length to the farthest indoor unit) + (0.80 x number of bent on the piping) [m]

6-4. Operation temperature range

• Cooling

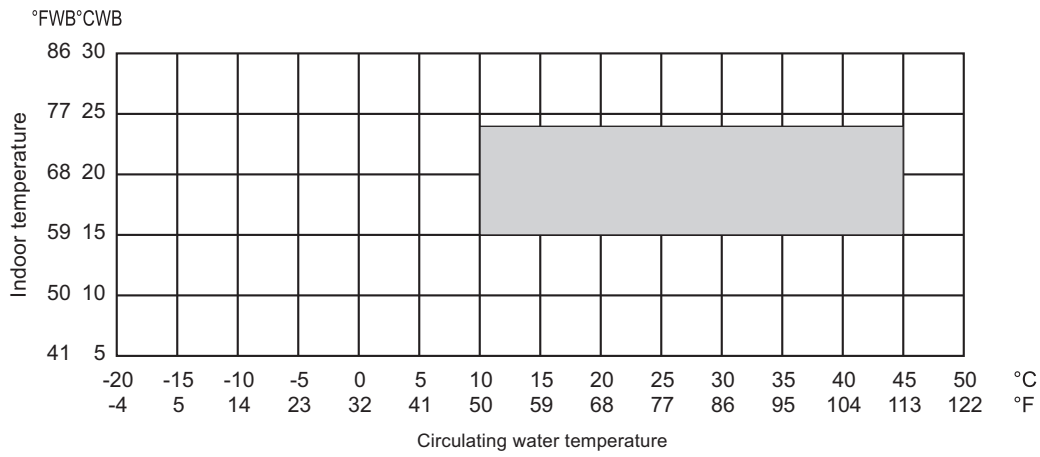

• Heating

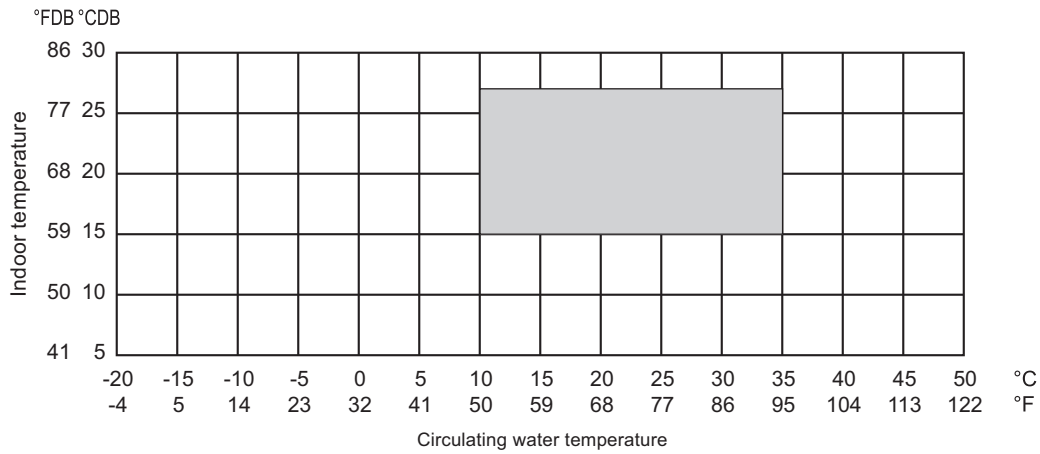

7-1. Designing of water circuit system

1) Example of basic water circuit

The water circuit of the water heat source CITY MULTI connects the heat source unit with the cooling tower/auxiliary heat source/heat storage tank/circulation pump with a single system water piping as shown in the figure below. The selector valve automatically controls to circulate water toward the cooling tower in the cooling season, while toward the heat storage tank in the heating season. If the circulation water temperature is kept in a range of 10~45°C [50~113°F]* regardless of the building load, the water heat source CITY MULTI can be operated for either cooling or heating. Therefore in the summer when only cooling load exists, the temperature rise of circulation water will be suppressed by operating the cooling tower. While in the winter when heating load increases, the temperature of circulation water may be dropped below 10°C [50°F]. Under such situation, the circulation water will be heated with the auxiliary heat source if it drops below a certain temperature.

When the thermal balance between cooling and heating operation is in a correct proportion, the operation of the auxiliary heat source and cooling tower is not required.

In order to control the above thermal balance properly and use thermal energy effectively, utilizing of heat storage tanks, and night-time discounted electric power as a auxiliary heat source will be economical.

Meantime as this system uses plural sets of heat source unit equipped with water heat exchangers, water quality control is important. Therefore it is recommended to use closed type cooling towers as much as possible to prevent the circulation water from being contaminated.

When open type cooling towers are used, it is essential to provide proper maintenance control such as that to install water treatment system to prevent troubles caused by contaminated circulation water.

*10~45°C [50~113°F] : 50%~130% of indoor units can be connected

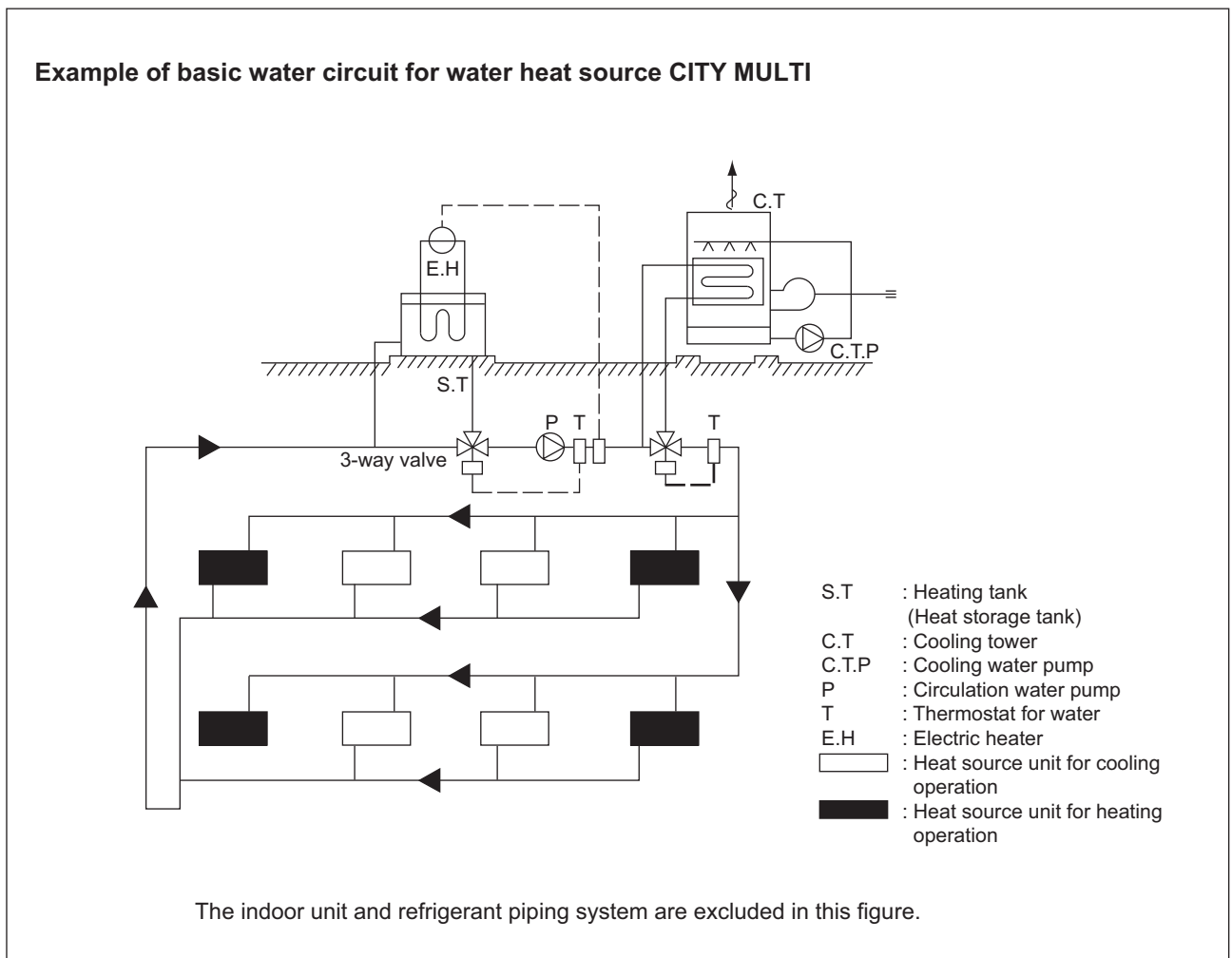

WY 575V

2) Cooling tower

a) Types of cooling tower

The cooling towers presently used include the open type cooling tower, open type cooling tower + heat exchanger, closed type cooling tower, and air-cooled type cooling tower. However, as the quality control of circulation water is essential when units are installed in decentralized state inside a building, the closed type cooling tower is generally employed in such case.

Although the circulation water will not be contaminated by atmospheric air, it is recommended to periodically blow water inside the system and replenish fresh water instead.

In a district where the coil may be frozen in the winter, it is necessary to apply antifreeze solution to the circulation water, or take freeze protection measures such as to automatically discharge water inside the cooling coil at the stopping of the pump.

When the open type cooling tower is used, be sure to install a water quality control device in addition to the freeze protection measures, as the water may be deteriorated by atmospheric contaminants entered into the cooling tower and dissolved into the circulation water.

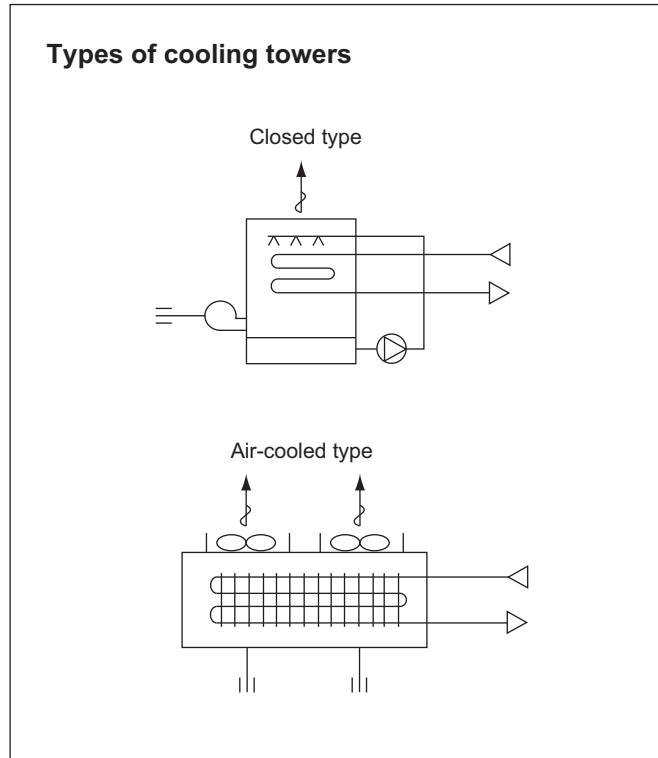

b) Calculation method of cooling tower capacity

All units of the water heat source CITY MULTI may possibly be in cooling operation temporarily (at pulling down) in the summer, however, it is not necessary to determine the capacity according to the total cooling capacity of all CITY MULTI units as this system has a wide operating water temperature range (10~45°C) [50~113°F].

It is determined in accordance with the value obtained by adding the maximum cooling load of an actual building, the input heat equivalent value of all CITY MULTI units, and the cooling load of the circulating pumps. Please check for the values of the cooling water volume and circulation water volume.

$$\text{Cooling tower capacity} = \frac{Q_c + 860 \times (\Sigma Q_w + P_w)}{3,900} \quad (\text{Refrigeration ton})$$

- Q_c : Maximum cooling load under actual state (kcal/h)
- Q_w : Total input of water heat source CITY MULTI at simultaneous operation under maximum state (kW)
- P_w : Shaft power of circulation pumps (kW)

$$\text{Cooling tower capacity} = \frac{Q_c + 3,412 \times (\Sigma Q_w + P_w)}{15,500} \quad (\text{Refrigeration ton})$$

- Q_c : Maximum cooling load under actual state (BTU/h)
- Q_w : Total input of water heat source CITY MULTI at simultaneous operation under maximum state (kW)
- P_w : Shaft power of circulation pumps (kW)

* 1 Refrigerant ton of cooling tower capacity ≈ US refrigerant ton × (1 + 0.3)
= 3,900 kcal/h = 15,500 BTU/h

3) Auxiliary heat source and heat storage tank

When the heating load is larger than the cooling load, the circulation water temperature lowers in accordance with the heat balance of the system. It should be heated by the auxiliary heat source in order to keep the inlet water temperature within the operating range (10°C [50°F] or more) of the water heat source CITY MULTI.

Further in order to operate the water heat source CITY MULTI effectively, it is recommended to utilize the heat storage tank to cover the warming up load in the morning and the insufficient heat amount. Effective heat utilization can be expected to cover insufficient heat at the warming up in the next morning or peak load time by storing heat by installing a heat storage tank or operating a low load auxiliary heat source at the stopping of the water heat source CITY MULTI. As it can also be possible to reduce the running cost through the heat storage by using the discounted night-time electric power, using both auxiliary heat source and heat storage tank together is recommended. The effective temperature difference of an ordinary heat storage tank shows about 5°C [41°F] even with the storing temperature at 45°C [113°F]. However with the water heat source CITY MULTI, it can be utilized as heating heat source up to 15°C [59°F] with an effective temperature of a high 30°C [54°F] approximately, thus the capacity of the heat storage tank can be minimized.

a) Auxiliary heat source

The following can be used as the auxiliary heat source.

- Boiler (Heavy oil, kerosine, gas, electricity)
- Electric heat (Insertion of electric heater into heat storage tank)
- Outdoor air (Air-heat source heat pump chiller)
- Warm discharge water (Exhaust water heat from machines inside building and hot water supply)
- Utilization of night-time lighting
- Solar heat

Please note that the auxiliary heat source should be selected after studying your operating environment and economical feasibility.

Determining the auxiliary heat source capacity

For the CITY MULTI water heat source system, a heat storage tank is recommended to use. When employment of the heat storage tank is difficult, the warming up operation should be arranged to cover the starting up heating load. Since the holding water inside the piping circuit owns heat capacity and the warming up operation can be assumed for about one hour except that in a cold region, the heat storage tank capacity is required to be that at the maximum daily heating load including the warming up load at the next morning of the holiday. However the auxiliary heat source capacity should be determined by the daily heating load including warming up load on the week day. For the load at the next morning of the holiday, heat storage is required by operating the auxiliary heat source even outside of the ordinary working hour.

When heat storage tank is not used

$$QH = HC_T \left(1 - \frac{1}{COP_h} \right) - 1000 \times V_w \times \Delta T - 860 \times P_w$$

- | | | |
|------------------|--|-------------------|
| QH | : Auxiliary heat source capacity | (kcal/h) |
| HC _T | : Total heating capacity of each water heat source CITY MULTI | (kcal/h) |
| COP _H | : COP of water heat source CITY MULTI at heating | |
| V _w | : Holding water volume inside piping | (m ³) |
| ΔT | : Allowable water temperature drop = T _{WH} - T _{WL} | (°C) |
| T _{WH} | : Heat source water temperature at high temperature side | (°C) |
| T _{WL} | : Heat source water temperature at low temperature side | (°C) |
| P _w | : Heat source water pump shaft power | (kW) |

$$QH = HC_T \left(1 - \frac{1}{COP_h} \right) - 8.343 \times V_w \times \Delta T - 3412 \times P_w$$

- | | | |
|------------------|--|---------|
| QH | : Auxiliary heat source capacity | (BTU/h) |
| HC _T | : Total heating capacity of each water heat source CITY MULTI | (BTU/h) |
| COP _H | : COP of water heat source CITY MULTI at heating | |
| V _w | : Holding water volume inside piping | (G) |
| ΔT | : Allowable water temperature drop = T _{WH} - T _{WL} | (°F) |
| T _{WH} | : Heat source water temperature at high temperature side | (°F) |
| T _{WL} | : Heat source water temperature at low temperature side | (°F) |
| P _w | : Heat source water pump shaft power | (kW) |

When heat storage tank is not used

$$QH = \frac{HQ_{1T} \cdot \left(1 - \frac{1}{COP_h} \right) - 860 \times P_w \times T_2}{T_1} \times K \quad (\text{kcal})$$

- QH_{1T} : Total of heating load on weekday including warming up (kcal/day)
- T₁ : Operating hour of auxiliary heat source (h)
- T₂ : Operating hour of heat source water pump (h)
- K : Allowance factor (Heat storage tank, piping loss, etc.) 1.05~1.10

HQ_{1T} is calculated from the result of steady state load calculation similarly by using the equation below.

$$HQ_{1T} = 1.15 \times (\Sigma Q'a + \Sigma Q'b + \Sigma Q'c + \Sigma Q'd + \Sigma Q'f) T_2 - \Psi (\Sigma Qe_1 + \Sigma Qe_2 + \Sigma Qe_3) (T_2 - 1)$$

- Q'a : Thermal load from external wall/roof in each zone (kcal/h)
- Q'b : Thermal load from glass window in each zone (kcal/h)
- Q'c : Thermal load from partition/ceiling/floor in each zone (kcal/h)
- Q'd : Thermal load by infiltration in each zone (kcal/h)
- Q'f : Fresh outdoor air load in each zone (kcal/h)
- Q'e₁ : Thermal load from human body in each zone (kcal/h)
- Q'e₂ : Thermal load from lighting fixture in each zone (kcal/h)
- Q'e₃ : Thermal load from equipment in each zone (kcal/h)
- Ψ : Radiation load rate 0.6~0.8
- T₂ : Air conditioning hour

$$QH = \frac{HQ_{1T} \cdot \left(1 - \frac{1}{COP_h} \right) - 3,412 \times P_w \times T_2}{T_1} \times K \quad (\text{BTU})$$

- QH_{1T} : Total of heating load on weekday including warming up (BTU/day)
- T₁ : Operating hour of auxiliary heat source (h)
- T₂ : Operating hour of heat source water pump (h)
- K : Allowance factor (Heat storage tank, piping loss, etc.) 1.05~1.10

HQ_{1T} is calculated from the result of steady state load calculation similarly by using the equation below.

$$HQ_{1T} = 1.15 \times (\Sigma Q'a + \Sigma Q'b + \Sigma Q'c + \Sigma Q'd + \Sigma Q'f) T_2 - \Psi (\Sigma Qe_1 + \Sigma Qe_2 + \Sigma Qe_3) (T_2 - 1)$$

- Q'a : Thermal load from external wall/roof in each zone (BTU/h)
- Q'b : Thermal load from glass window in each zone (BTU/h)
- Q'c : Thermal load from partition/ceiling/floor in each zone (BTU/h)
- Q'd : Thermal load by infiltration in each zone (BTU/h)
- Q'f : Fresh outdoor air load in each zone (BTU/h)
- Q'e₁ : Thermal load from human body in each zone (BTU/h)
- Q'e₂ : Thermal load from lighting fixture in each zone (BTU/h)
- Q'e₃ : Thermal load from equipment in each zone (BTU/h)
- Ψ : Radiation load rate 0.6~0.8
- T₂ : Air conditioning hour

b) Heat storage tank

Heat storage tank can be classified by types into the open type heat storage tank exposed to atmosphere, and the closed type heat storage tank with structure separated from atmosphere. Although the size of the tank and its installation place should be taken into account, the closed type tank is being usually employed by considering corrosion problems.

The capacity of heat storage tanks is determined in accordance with the daily maximum heating load that includes warming up load to be applied for the day after the holiday.

When auxiliary heat source is operated during operation and even after stopping of water heat source CITY MULTI unit

$$V = \frac{HQ_{2T} \left(1 - \frac{1}{COP_h} \right) - 860 \times P_w \times T_2 - Q_H \times T_2}{\Delta T \times 1,000 \times \eta V} \quad (\text{ton})$$

HQ_{2T} : Maximum heating load including load required for the day after the holiday (kcal/day)
 ΔT : Temperature difference utilized by heat storage tank (°C)
 ηV : Heat storage tank efficiency

$$HQ_{2T} : 1.3 \times (\Sigma Q'a + \Sigma Q'c + \Sigma Q'd + \Sigma Q'f) T_2 - \psi (\Sigma Qe2 + \Sigma Qe3) (T_2 - 1)$$

$$V = \frac{HQ_{2T} \left(1 - \frac{1}{COP_h} \right) - 3,412 \times P_w \times T_2 - Q_H \times T_2}{\Delta T \times \eta V} \quad (\text{lbs})$$

HQ_{2T} : Maximum heating load including load required for the day after the holiday (BTU/day)
 ΔT : Temperature difference utilized by heat storage tank (°F)
 ηV : Heat storage tank efficiency

$$HQ_{2T} : 1.3 \times (\Sigma Q'a + \Sigma Q'c + \Sigma Q'd + \Sigma Q'f) T_2 - \psi (\Sigma Qe2 + \Sigma Qe3) (T_2 - 1)$$

When auxiliary heat source is operated after stopping of water heat source CITY MULTI unit

$$V = \frac{HQ_{2T} \left(1 - \frac{1}{COP_h} \right) - 860 \times P_w \times T_2}{\Delta T \times 1,000 \times \eta V} \quad (\text{ton})$$

HQ_{2T} : Maximum heating load including load required for the day after the holiday (kcal/day)
 ΔT : Temperature difference utilized by heat storage tank (°C)
 ηV : Heat storage tank efficiency

$$HQ_{2T} : 1.3 \times (\Sigma Q'a + \Sigma Q'c + \Sigma Q'd + \Sigma Q'f) T_2 - \psi (\Sigma Qe2 + \Sigma Qe3) (T_2 - 1)$$

$$V = \frac{HQ_{2T} \left(1 - \frac{1}{COP_h} \right) - 3,412 \times P_w \times T_2}{\Delta T \times \eta V} \quad (\text{lbs})$$

HQ_{2T} : Maximum heating load including load required for the day after the holiday (BTU/day)
 ΔT : Temperature difference utilized by heat storage tank (°F)
 ηV : Heat storage tank efficiency

$$HQ_{2T} : 1.3 \times (\Sigma Q'a + \Sigma Q'c + \Sigma Q'd + \Sigma Q'f) T_2 - \psi (\Sigma Qe2 + \Sigma Qe3) (T_2 - 1)$$

WY 575V

4) Piping system

The following items should be kept in your mind in planning / designing water circuits.

- a) All units should be constituted in a single circuit in principle.
- b) When plural numbers of the water heat source CITY MULTI unit are installed, the rated circulating water flow rate should be kept by making the piping resistance to each unit almost same value. As an example, the reverse return system as shown below may be employed.
- c) Depending on the structure of a building, the water circuit may be prefabricated by making the layout uniform.
- d) When a closed type piping circuit is constructed, install an expansion tank usable commonly for a make-up water tank to absorb the expansion/contraction of water caused by temperature fluctuation.
- e) If the operating temperature range of circulation water stays within the temperature near the normal temperature (summer :29.4°C [85°F], winter :21.1°C [70°F]), thermal insulation or anti-sweating work is not required for the piping inside buildings.

In case of the conditions below, however, thermal insulation is required.

- When well water is used for heat source water.
- When piped to outdoor or a place where freezing may be caused.
- When vapor condensation may be generated on piping due to an increase in dry bulb temperature caused by the entry of fresh outdoor air.

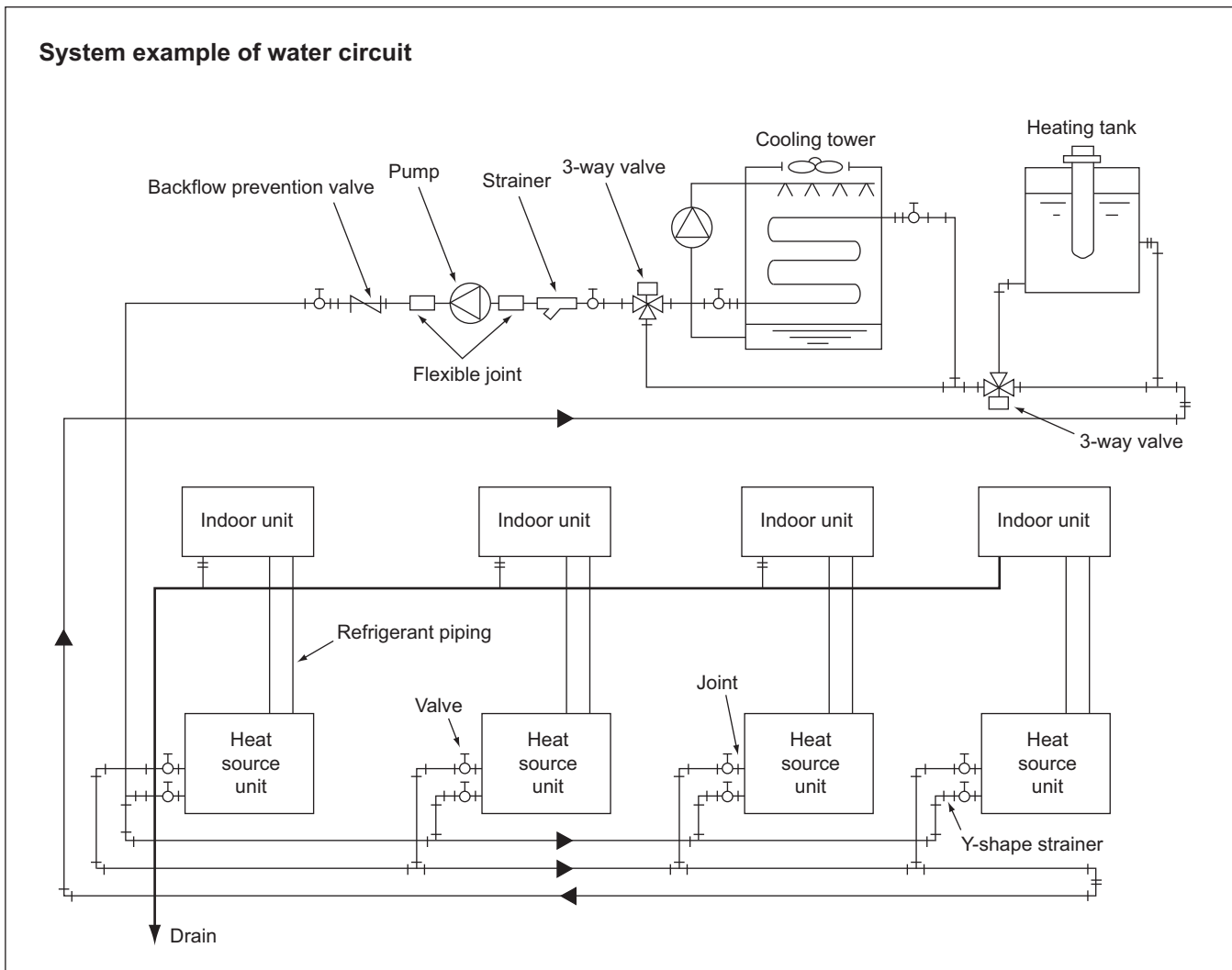

WY 575V

5) Practical System Examples and Circulation Water Control

Since the water heat source CITY MULTI is of water heat source system, versatile systems can be constituted by combining it with various heat sources.

The practical system examples are given below.

Either cooling or heating operation can be performed if the circulation water temperature of the water heat source CITY MULTI stays within a range of 10~45°C [50~113°F]. However, the circulation water temperature near 32°C [90°F] for cooling and 20°C [68°F] for heating is recommended by taking the life, power consumption and capacity of the air conditioning units into consideration. The detail of the control is also shown below.

Example-1 Combination of closed type cooling tower and hot water heat storage tank (using underground hollow slab)

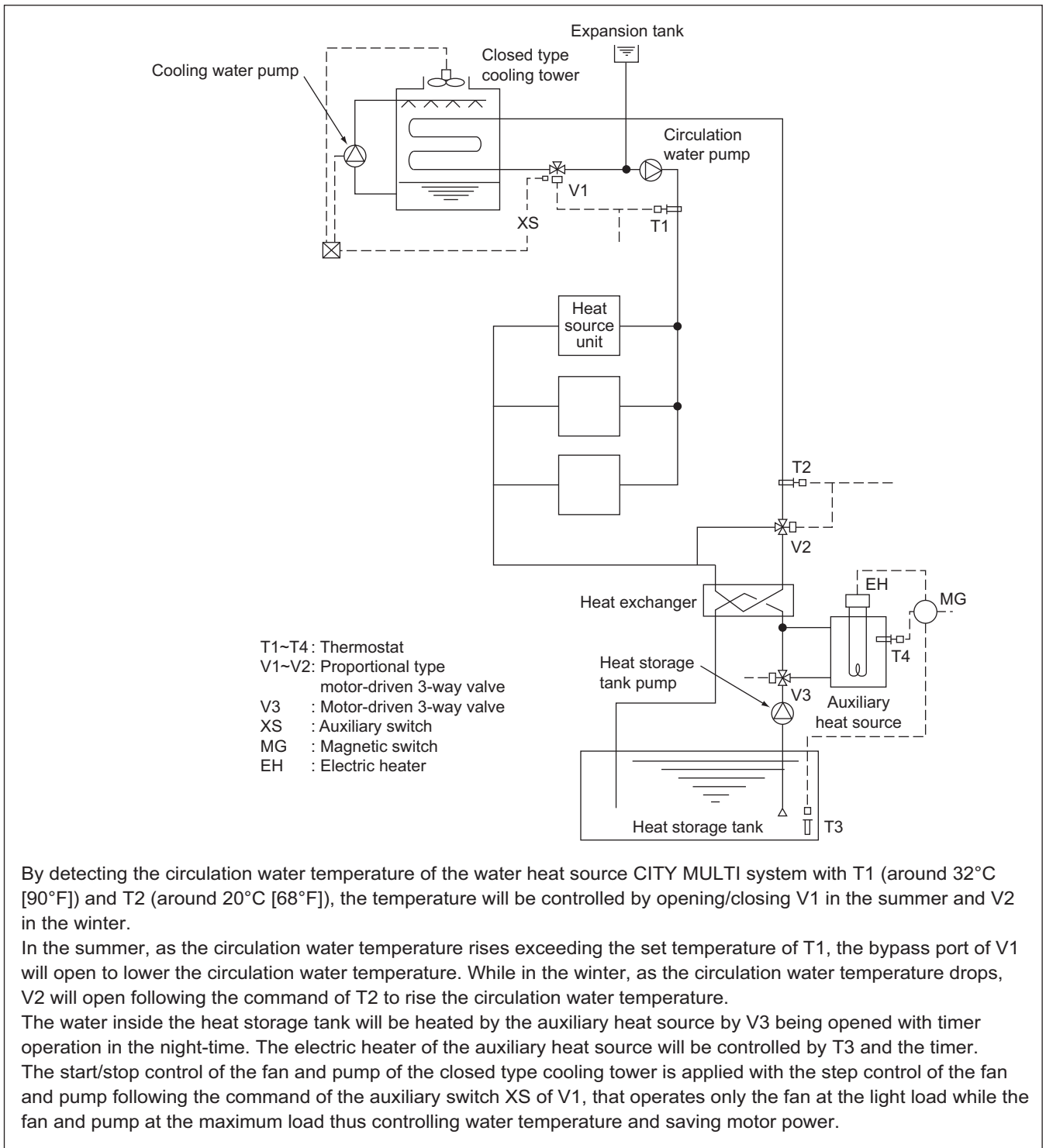

Example-2 Combination of closed type cooling tower and hot water heat storage tank

- T1 : Proportional type, insertion system thermostat
- T2 : Proportional type, insertion system thermostat
- T3 : Proportional type, insertion system thermostat
- V1 : Proportional type, motor-driven 3-way valve
- V2 : Proportional type, motor-driven 3-way valve
- XS : Auxiliary switch (Duplex switch type)
- SC : Step controller
- R : Relay
- MG : Magnetic

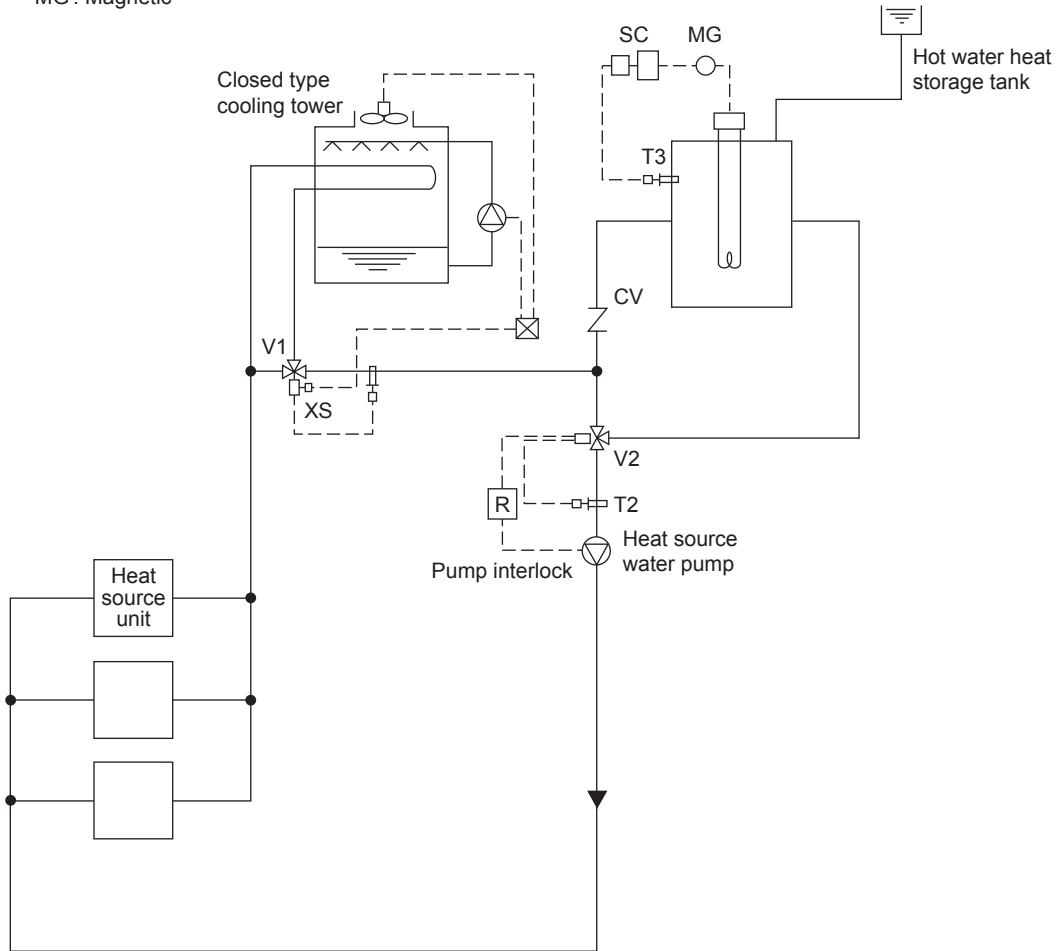

In the summer, as the circulation water temperature rises exceeding the set temperature of T1, the bypass port of V1 will open to lower the circulation water temperature. In the winter, if the circulation water temperature stays below 25°C [77°F], V2 will open/close by the command of T2 to keep the circulation water temperature constant. The temperature of the hot water inside the heat storage tank will be controlled through the step control of the electric heater by step controller operation following the command of T3. During the stopping of the heat source water pump, the bypass port of V2 will be closed fully by interlocking thus preventing the high temperature water from entering into the system at the starting of the pump. The start/stop control of the fan and pump of the closed type cooling tower is applied with the step control of the fan and pump following the command of the auxiliary switch XS of V1, that operates only the fan at the light load while the fan and pump at the maximum load thus controlling water temperature and saving motor power.

WY 575V

Example-3 Combination of closed type cooling tower and boiler

- T1 : Proportional type, insertion system thermostat
 T2 : Proportional type, insertion system thermostat
 T3 : Proportional type, insertion system thermostat
 V1 : Proportional type, motor-driven 3-way valve
 S : Selector switch
 R : Relay
 XS : Auxiliary switch (Duplex switch type)

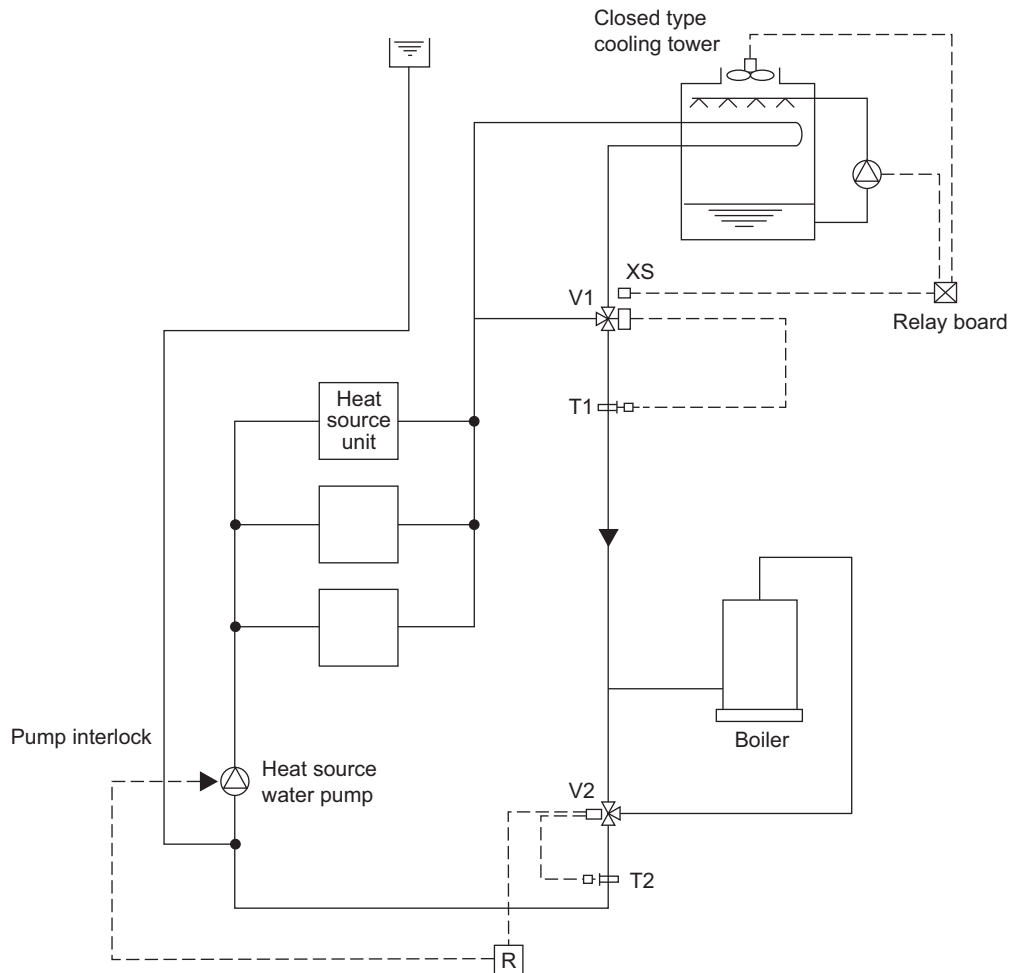

In the summer, as the circulation water temperature rises exceeding the set temperature of T1, the bypass port of V1 will close to lower the circulation water temperature. In the winter, if the circulation water temperature drops below 25°C [77°F], V2 will conduct water temperature control to keep the circulation water temperature constant. During the stopping of the heat source water pump, the bypass port of V2 will be closed fully by interlocking. The start/stop control of the fan and pump of the closed type cooling tower is applied with the step control following the command of the auxiliary switch XS of V1, thus controlling water temperature and saving motor power.

Example-4 Combination of closed type cooling tower and heat exchanger (of other heat source)

- T1 : Proportional type, insertion system thermostat
- T2 : Proportional type, insertion system thermostat
- V1 : Proportional type, motor-driven 3-way valve
- V2 : Proportional type, motor-driven 3-way valve
- S : Selector switch
- R : Relay
- XS : Auxiliary switch (Duplex switch type)

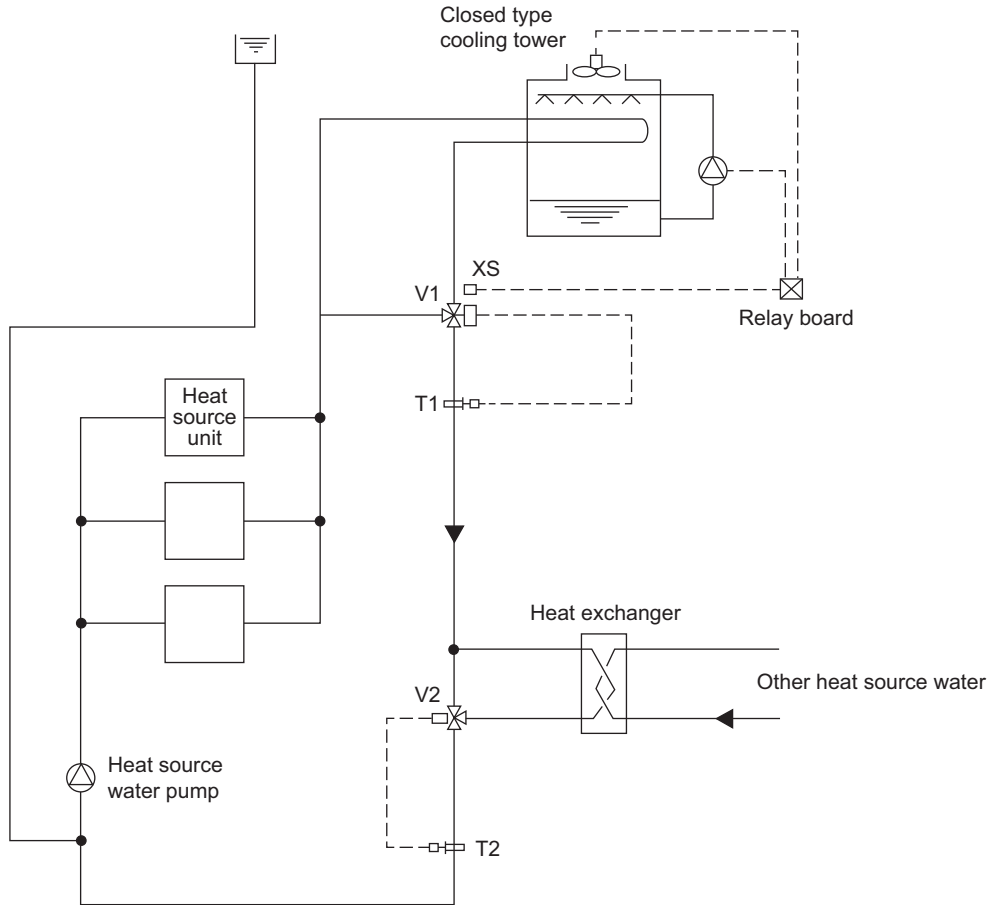

In the summer, as the circulation water temperature rises exceeding the set temperature of T1, the bypass port of V1 will close to lower the circulation water temperature. In the winter, if the circulation water temperature drops below 26°C [79°F], V2 will conduct water temperature control to keep the circulation water temperature constant. During the stopping of the heat source water pump, the bypass port of V2 will be closed fully by interlocking. The start/stop control of the fan and pump of the closed type cooling tower is applied with the step control following the command of the auxiliary switch XS of V1, thus controlling water temperature and saving motor power.

6) Pump interlock circuit

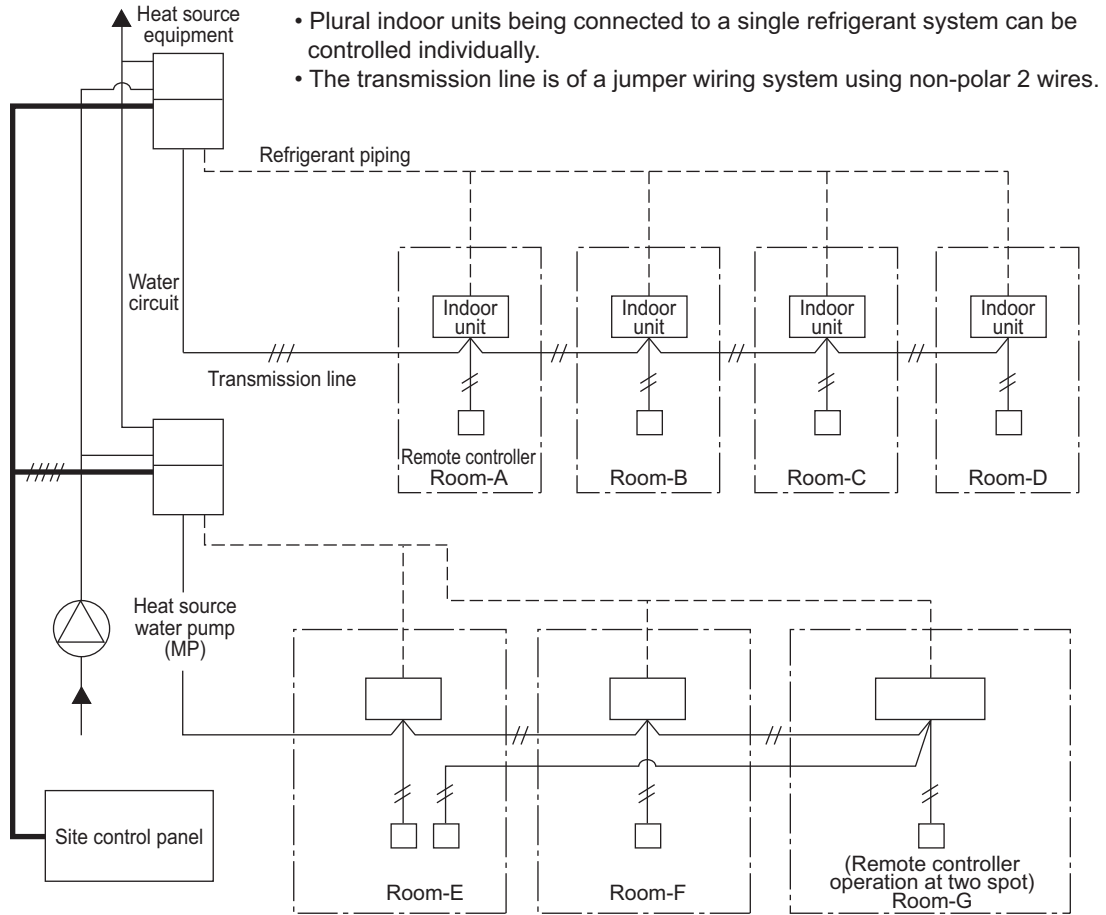

Wiring diagram

This circuit uses the "Terminal block for pump interlock (TB8)" inside the electrical parts box of the heat source equipment. This circuit is for interlocking of the heat source equipment operation and the heat source water pump.

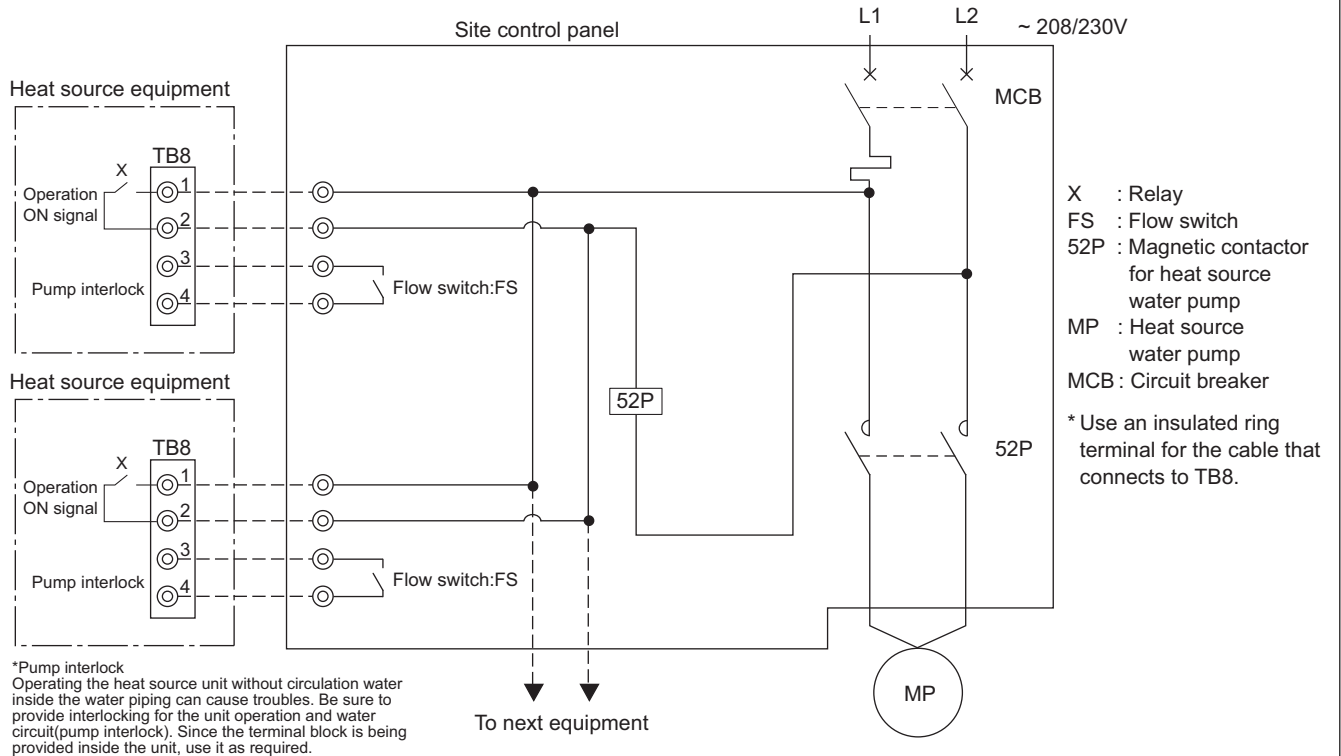

*Pump interlock
 Operating the heat source unit without circulation water inside the water piping can cause troubles. Be sure to provide interlocking for the unit operation and water circuit(pump interlock). Since the terminal block is being provided inside the unit, use it as required.

Use the flow switch (FS)

Operation ON signal

Terminal No.	TB8-1, 2																														
Output	Relay contacts output Rated voltage: 3~: 208/230V Rated load: 1 A																														
Operation	<ul style="list-style-type: none"> When setting No.917 for Dip switch 4 (Dip switch 6-10 is ON) is OFF. The relay closes during compressor operation. <table border="1" style="margin-left: auto; margin-right: auto;"> <tr> <th colspan="10">SW4 0: OFF, 1: ON</th> </tr> <tr> <td>1</td><td>2</td><td>3</td><td>4</td><td>5</td><td>6</td><td>7</td><td>8</td><td>9</td><td>10</td> </tr> <tr> <td>1</td><td>0</td><td>1</td><td>0</td><td>1</td><td>0</td><td>0</td><td>1</td><td>1</td><td>1</td> </tr> </table> <ul style="list-style-type: none"> When setting No.917 for Dip switch 4 (Dip switch 6-10 is ON) is ON. The relay closes during reception of cooling or the heating operation signal from the controller. (Note: It is output even if the thermostat is OFF (when the compressor is stopped).) 	SW4 0: OFF, 1: ON										1	2	3	4	5	6	7	8	9	10	1	0	1	0	1	0	0	1	1	1
SW4 0: OFF, 1: ON																															
1	2	3	4	5	6	7	8	9	10																						
1	0	1	0	1	0	0	1	1	1																						

Pump Interlock

Terminal No.	TB8-3, 4
Input	Level signal
Operation	If the circuit between TB8-3 and TB8-4 is open, compressor operation is prohibited.

*Remove the short circuit wire between 3 and 4 when wiring to TB8.
To prevent a false detection of error resulting from contact failure, use a flow switch with a minimum guaranteed current of 5 mA or below for FS.

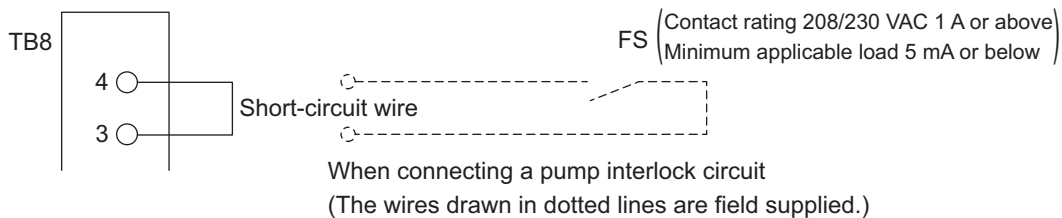

7-2. Water piping work

Although the water piping for the CITY MULTI WY system does not differ from that for ordinary air conditioning systems, pay special attention to the items below in conducting the piping work.

1) Items to be observed on installation work

- The water pressure resistance of the water pipes in the heat source unit is 2.0MPa [290psi].
- In order to equalize piping resistance for each unit, adapt the reverse return system.
- Mount a joint and a valve onto the water outlet/inlet of the unit to allow for maintenance, inspection and replacement work. Be sure to mount a strainer at the water inlet piping of the unit. (The strainer is required at the circulation water inlet to protect the heat source unit.)

* The installation example of the heat source unit is shown right.

- Be sure to provide an air relief opening on the water piping properly, and purge air after feeding water to the piping system.
- Condensate will generate at the low temperature part inside the heat source equipment. Connect drain piping to the drain piping connection located at the bottom of the heat source equipment to discharge it outside the equipment.
- Mount a backflow prevention valve and a flexible joint for vibration control onto the pump.
- Provide a sleeve to the penetrating parts of the wall to prevent the piping.
- Fasten the piping with metal fitting, arrange the piping not to expose to cutting or bending force, and pay sufficient care for possible vibration.
- Be careful not to erroneously judge the position of the inlet and outlet of water.

(Lower position : Inlet, Upper position : Outlet)

- When connecting heat source unit water piping and water piping on site, apply liquid sealing material for water piping over the sealing tape before connection.
- This unit doesn't include a heater to prevent freezing within tubes. If the water flow is stopped on low ambient, drain the water out.
- The unused knockout holes should be closed and the refrigerant pipes, water pipes, power source and transmission wires access holes should be filled with putty.
- The drain plug is installed on the back of the unit at factory for field-connection of the drain pipes on the front of the unit. Move the plug to the front to connect the drain pipes on the back. Verify that there are no leaks from pipe connections.
- For installing two units, install water pipes in parallel to each other so that the water flow rate through both units will be equal.
- Wrap the sealing tape as follows.

- ① Wrap the joint with sealing tape in the direction of the threads (clockwise), and do not let the tape run over the edge.
- ② Overlap the sealing tape by two-thirds to three-fourths of its width on each turn. Press the tape with your fingers so that it is pressed firmly against each thread.
- ③ Leave the 1.5th through 2nd farthest threads away from the pipe end unwrapped.

- Hold the pipe on the unit side in place with a spanner when installing the pipes or strainer. Tighten screws to a torque of 150N • m.

2) Thermal insulation work

Thermal insulation or anti sweating work is not required for the piping inside buildings in the case of the CITY MULTI WY system if the operating temperature range of circulation water stays within the temperature near the normal (summer :30°C [86°F], winter : 20°C [68°F]).

In case of the conditions below, however, thermal insulation is required.

- Use of well water for heat source water
- Outdoor piping portions
- Indoor piping portions where freezing may be caused in winter

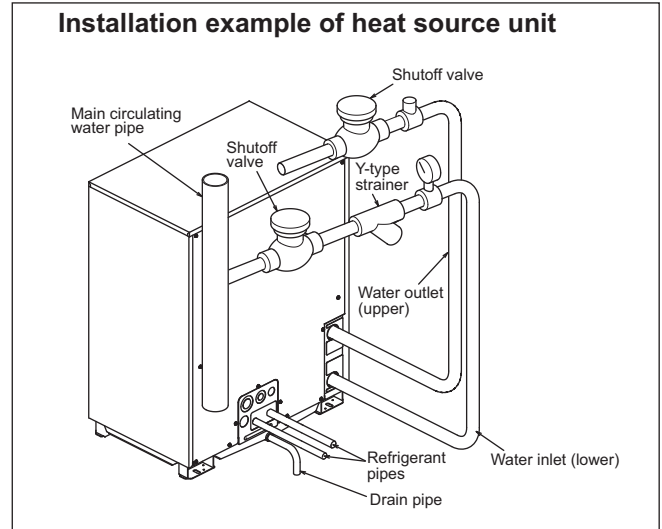

- A place where vapor condensation may be generated on piping due to an increase in dry bulb temperature inside the ceiling caused by the entry of fresh outdoor air
- Drain piping portions

3) Water treatment and water quality control

For the circulation water cooling tower of the CITY MULTI WY system, employment of the closed type is recommended to keep water quality. However, in the case that an open type cooling tower is employed or the circulating water quality is inferior, scale will adhere onto the water heat exchanger leading to the decreased heat exchange capacity or the corrosion of the heat exchanger. Be sufficiently careful for water quality control and water treatment at the installation of the circulation water system.

- Removal of impurities inside piping
Be careful not to allow impurities such as welding fragment, remaining sealing material and rust from mixing into the piping during installation work.
- Water treatment

The water quality standards have been established by the industry (Japan Refrigeration, Air Conditioning Industry Association, in case of Japan) for water treatment to be applied.

Items	Lower mid-range temperature water system		Tendency	
	Recirculating water [20<T<60°C] [68<T<140°F]	Make-up water	Corrosive	Scale-forming
pH (25°C[77°F])	7.0 ~ 8.0	7.0 ~ 8.0	○	○
Electric conductivity (mS/m) (25°C[77°F])	30 or less	30 or less	○	○
(μS/cm) (25°C[77°F])	[300 or less]	[300 or less]	○	○
Chloride ion (mg Cl / l)	50 or less	50 or less	○	
Sulfate ion (mg SO ₄ ²⁻ / l)	50 or less	50 or less	○	
Acid consumption (pH4.8) (mg CaCO ₃ / l)	50 or less	50 or less		○
Total hardness (mg CaCO ₃ / l)	70 or less	70 or less		○
Calcium hardness (mg CaCO ₃ / l)	50 or less	50 or less		○
Ionic silica (mg SiO ₂ / l)	30 or less	30 or less		○
Iron (mg Fe / l)	1.0 or less	0.3 or less	○	○
Copper (mg Cu / l)	1.0 or less	0.1 or less	○	
Sulfide ion (mg S ²⁻ / l)	not to be detected	not to be detected	○	
Ammonium ion (mg NH ₄ ⁺ / l)	0.3 or less	0.1 or less	○	
Residual chlorine (mg Cl / l)	0.25 or less	0.3 or less	○	
Free carbon dioxide (mg CO ₂ / l)	0.4 or less	4.0 or less	○	
Ryzner stability index	-	-	○	○

Reference : Guideline of Water Quality for Refrigeration and Air Conditioning Equipment. (JRA GL02E-1994)

In order to keep the water quality within such standards, you are kindly requested to conduct bleeding-off by overflow and periodical water quality tests, and use inhibitors to suppress condensation or corrosion. Since piping may be corroded by some kinds of inhibitor, consult an appropriate water treatment expert for proper water treatment.

4) Pump interlock

Operating the heat source unit without circulation water inside the water piping can cause a trouble. Be sure to provide interlocking for the unit operation and water circuit. Since the terminal block is being provided inside the unit, use it as required.

5) Handling plate heat exchangers for heat-source units

<Designing the piping system>

- Install a strainer (50 mesh or finer recommended) near the heat-source unit on the inlet side of the hot/cold water pipe and cooling-water pipe (hereafter referred to as water pipes) to prevent an infiltration of foreign materials of solid nature, such as dirt and sand, into the plate heat exchanger.
- Depending on the water quality, scale may form inside plate heat exchangers. Plate heat exchangers must be chemically cleaned regularly to remove scale formation. Install sluice valves on the water pipes, and provide ports for connecting a pipe between the sluice valves and the heat-source unit for chemical cleaning.
- On both the inlet and outlet sides of water pipes, provide a plug to remove trapped air and water (also to be used for cleaning heat-source units and for purging water before a period of nonuse in winter or at the end of an air conditioning season). Also, provide automatic air-vent valves where air is likely to be trapped (such as a pipe that runs vertically).
- In addition to installing the above-mentioned strainers, install a cleanable strainer near the pump pipe inlet.
- Keep the pipes properly insulated and take an appropriate measure against humidity to minimize heat loss and prevent freeze damage in severe cold climate.
- If the system is stopped during winter or at night in subfreezing temperatures, take appropriate measures to protect pipes from freezing (i.e., pipe purging and use of water-circulation pump or heater) and prevent resultant damage to the plate heat exchanger.

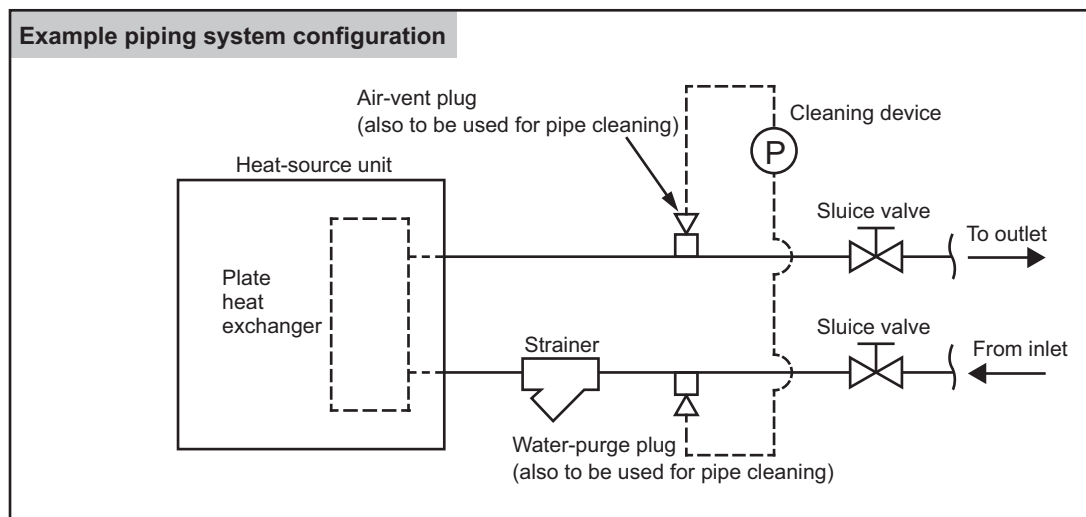

<Test run>

- Before performing a test run, check that the piping system is properly installed, especially the strainers, air-vents, automatic water-supply valves, expansion tanks, and systems.
- After the pipe system is filled with water, first, operate the pump alone to check the system for trapped air and adjust the water flow rate to prevent the plate heat exchanger from freezing. Take into consideration the water pressure loss before and after each heat-source unit, and make sure the water flow rate falls within the design water flow rate range. Stop the test run and correct any problems found, if any.
- At the completion of a test run, check the strainer at the inlet pipe of the heat-source unit and clean it as necessary.

<Daily maintenance>

- Controlling the water quality
Plate heat exchangers cannot be disassembled for cleaning and have no replaceable parts. Watch the water quality to prevent corrosion and scale formation. The quality of the water to be used for plate heat exchangers must meet the water quality guidelines JRA GL-02-1994 specified by Japan Refrigeration and Air conditioning Industry Association (JRAIA). (Refer to 3) Water treatment and water quality control.)
- Controlling the circulation water flow rate
Insufficient water rate will cause freeze damage to plate heat exchangers. Check for insufficient water flow caused by clogged strainer, trapped air in the system, or malfunction of the circulation water pump. Flow rate can also be checked by measuring the temperature or pressure difference between the inlet and outlet of plate heat exchangers. If the temperature or pressure difference goes outside of the specified range, stop the operation, remove the cause of the problem, and resume operation.
- What to do when the freeze protection trips
If the freeze protection trips during operation, be sure to remove its cause before resuming operation. Tripped freeze protection indicates that the system is partially frozen, and resuming operation without removing the cause of the problem will result in freeze damage to plate heat exchangers and/or pipes as well as resultant refrigerant leaks and infiltration of water into the refrigerant circuit.

<Maintaining plate heat exchangers>

Plate heat exchangers must be maintained in a planned and periodical manner to prevent scale formation, which may cause performance loss or decrease water flow rate that result in freeze damage to the plate heat exchanger.

- ♦ Check the following items before the operating season.
 1. Check that the water quality meets the specified water quality.
 2. Clean the strainers.
 3. Check that the water flow rate is adequate.
 4. Check for proper operation (e.g., pressure, flow rate, inlet/outlet temperatures).
- ♦ Plate heat exchangers cannot be disassembled for cleaning. Clean them in the following way.
 1. Make sure that there is a pipe connection port on the water inlet pipe.
Use formic acid, citric acid, oxalic acid, acetic acid, or phosphoric acid diluted to 5% to clean plate heat exchangers.
Do not use highly corrosive acids, such as hydrochloric acid, sulfuric acid, or nitric acid.
 2. Make sure that valves are installed before the inlet connection port and after the outlet connection port.
 3. Connect a pipe for circulating cleaning solution to the inlet/outlet pipes of the plate heat exchanger, fill the plate heat exchanger with cleaning solution at a temperature between 50 and 60°C, and circulate the cleaning solution with a pump for 2 to 5 hours. The cleaning time will depend on the temperature of the cleaning solution and the degree of scale formation. Use the color of the cleaning solution as a guide to determine how long the system needs to be cleaned.
 4. When done, discharge the cleaning solution out of the plate heat exchanger, fill it with sodium hydrate (NaOH) or sodium bicarbonate (NaHCO₃) diluted with water to 1 to 2%, and let the solution be circulated for 15 to 20 minutes until the cleaning solution is neutralized.
 5. After neutralizing the cleaning solution, thoroughly rinse the plate heat exchanger with clean water.
 6. When using a commercially available cleaning solution, make sure to use a solution not corrosive to stainless steel or copper.
 7. Consult the cleaning solution manufacture for details.
- ♦ At the completion of cleaning, check the system for proper operation.

8-1. JOINT

CITY MULTI units can be easily connected by using Joint sets and Header sets provided by Mitsubishi Electric. Four kinds of Joint sets are available for use. Refer to section 3 in "System Design" or the Installation Manual that comes with the Joint set for how to install the Joint set.

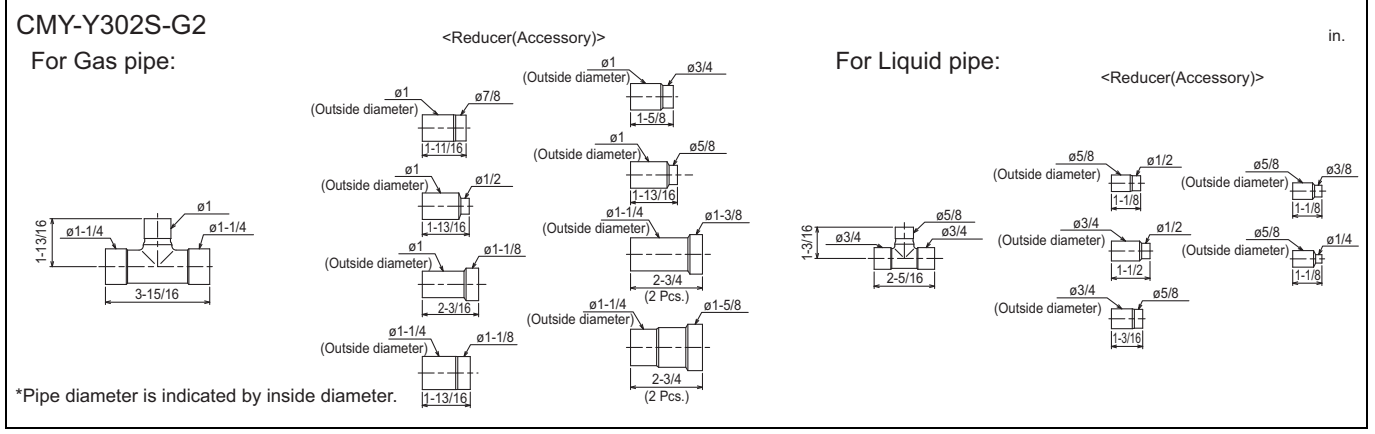
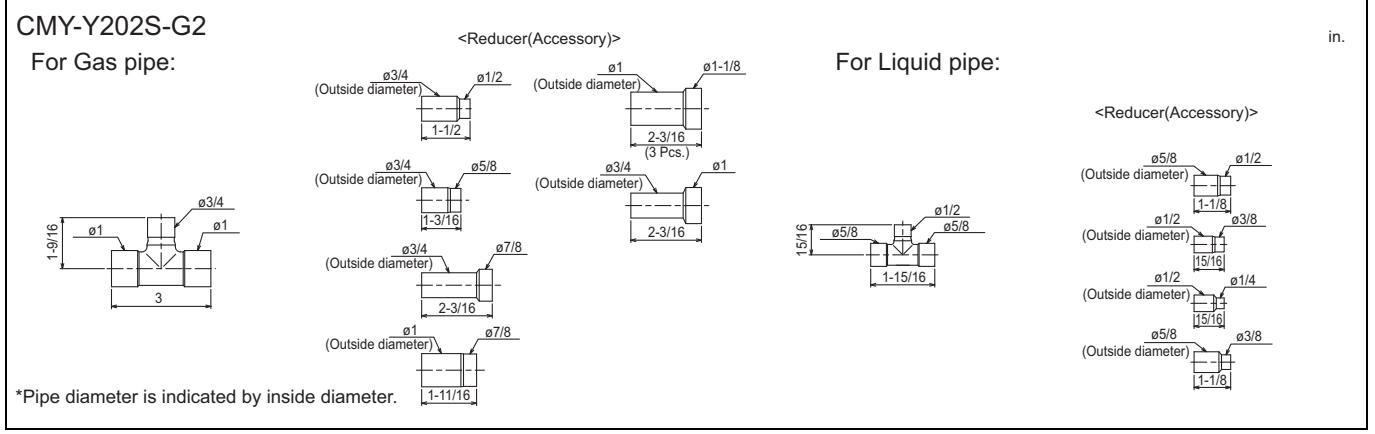
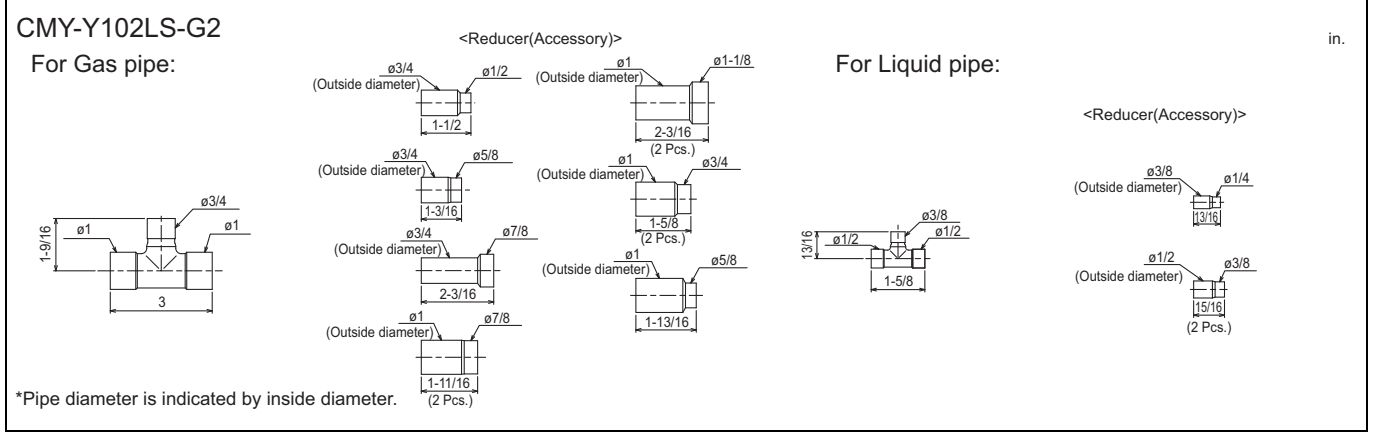
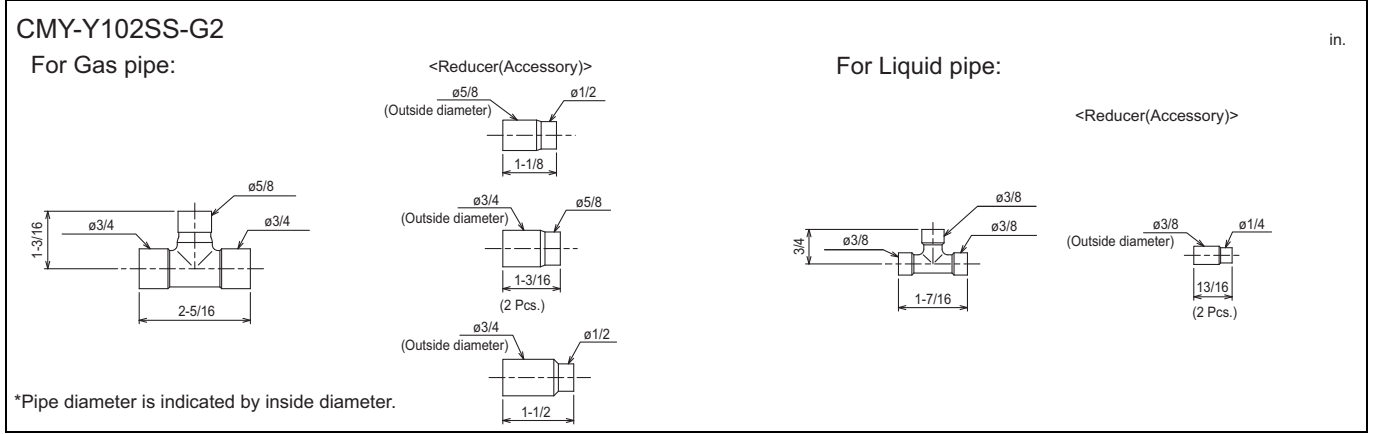

8-2. HEADER

CITY MULTI units can be easily connected by using Joint sets and Header sets provided by Mitsubishi Electric. Three kinds of Header sets are available for use. Refer to section 3 in "System Design" or the Installation Manual that comes with the Header set for how to install the Header set.

CMY-Y104C-G in.

For gas pipe:

For liquid pipe:

ID: Inner Diameter OD: Outer Diameter
NOTE: Besides above mentioned accessories, caps for $\phi 1/4"$, $\phi 3/8"$, $\phi 1/2"$, $\phi 5/8"$ pipes (each diameter 1 piece) are included in the Header set.

CMY-Y108C-G in.

For gas pipe:

For liquid pipe:

ID: Inner Diameter OD: Outer Diameter
NOTE: Besides above mentioned accessories, caps for $\phi 1/4"$, $\phi 3/8"$, $\phi 1/2"$, $\phi 5/8"$ pipes (each diameter 2 pieces) and 1 cap for $\phi 3/4"$ pipe are included in the Header set.

CMY-Y1010C-G in.

For gas pipe:

For liquid pipe:

ID: Inner Diameter OD: Outer Diameter
NOTE: Besides above mentioned accessories, caps for $\phi 1/4"$, $\phi 3/8"$, $\phi 1/2"$, $\phi 5/8"$ pipes (each diameter 2 pieces) and 1 cap for $\phi 3/4"$ pipe are included in the Header set.

WY 575V

8-3. OUTDOOR TWINNING KIT

The following optional Outdoor Twinning Kit is needed to use to combine multiple refrigerant pipes. Refer to the chapter entitled System Design Section for the details of selecting a proper twinning kit.

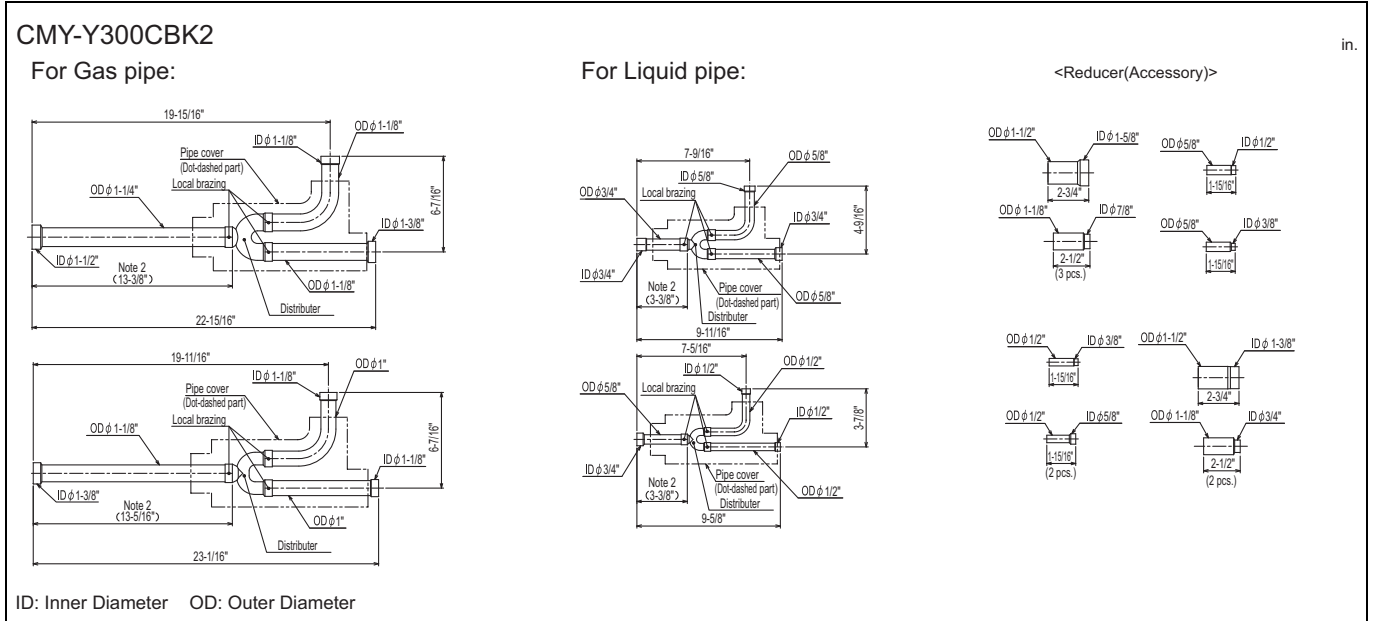
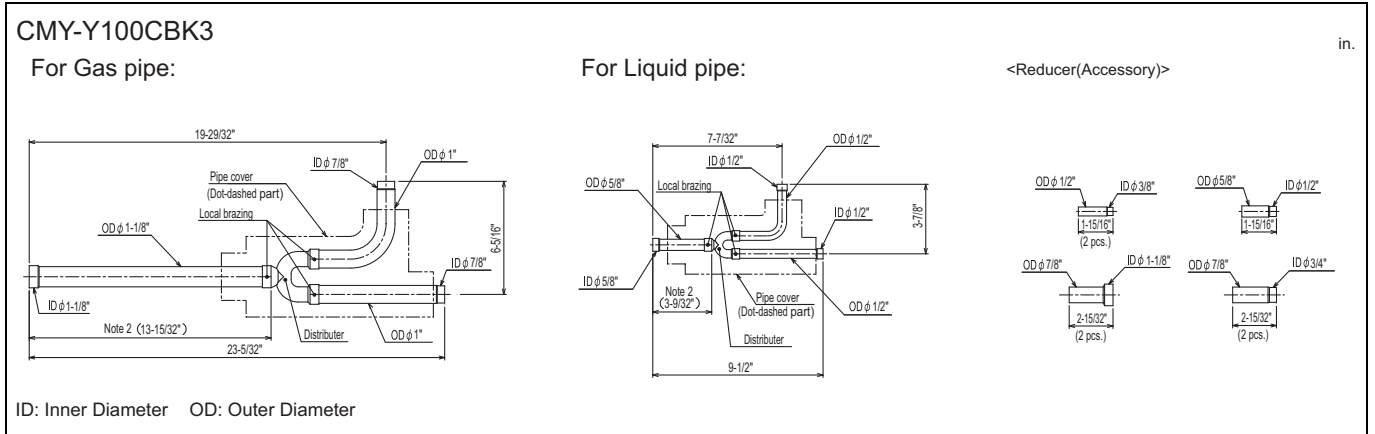

Note 1. Reference the attitude angle of the branch pipe below the fig.

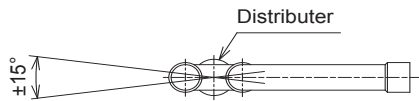

The angle of the branch pipe for high pressure is within $\pm 15^\circ$ against the horizontal plane.

2. Use the attached pipe to braze the port-opening of the distributor.
3. Pipe diameter is indicated by inside diameter.
4. Only use the Twinning pipe by Mitsubishi (optional parts) .

CITY MULTI

SYSTEM DESIGN WY SERIES - 575V

1. Electrical work.....	4 - 398
1-1.General cautions	4 - 398
1-2.Power supply for Indoor unit and Heat source unit.....	4 - 399
1-3.Power cable specifications	4 - 402
1-4.Power supply examples.....	4 - 403
2. M-NET control.....	4 - 406
2-1.Transmission cable length limitation.....	4 - 406
2-2.Transmission cable specifications	4 - 407
2-3.System configuration restrictions.....	4 - 408
2-4.Address setting.....	4 - 412
3. Piping Design.....	4 - 424
3-1.R410A Piping material	4 - 424
3-2.Piping Design	4 - 425
3-3.Refrigerant charging calculation	4 - 429
4. Installation.....	4 - 430
4-1.General requirements for installation.....	4 - 430
4-2.Spacing.....	4 - 430
4-3.Caution on selecting heat source unit	4 - 430
4-4.Piping direction	4 - 431

1-1. General cautions

- ① Follow ordinance of your governmental organization for technical standard related to electrical equipment, wiring regulations, and guidance of each electric power company.
- ② Wiring for control (hereinafter referred to as transmission cable) shall be (50mm[1-5/8in] or more) apart from power source wiring so that it is not influenced by electric noise from power source wiring. (Do not insert transmission cable and power source wire in the same conduit.)
- ③ Be sure to provide designated grounding work to heat source unit.
- ④ Give some allowance to wiring for electrical part box of indoor and heat source unit, because the box is sometimes removed at the time of service work.
- ⑤ Never connect 100V, 208-230V, 575V power source to terminal block of transmission cable. If connected, electrical parts will be damaged.
- ⑥ Use 2-core shield cable for transmission cable. If transmission cables of different systems are wired with the same multicore cable, the resultant poor transmitting and receiving will cause erroneous operations.
- ⑦ When extending the transmission line, make sure to extend the shield cable as well.

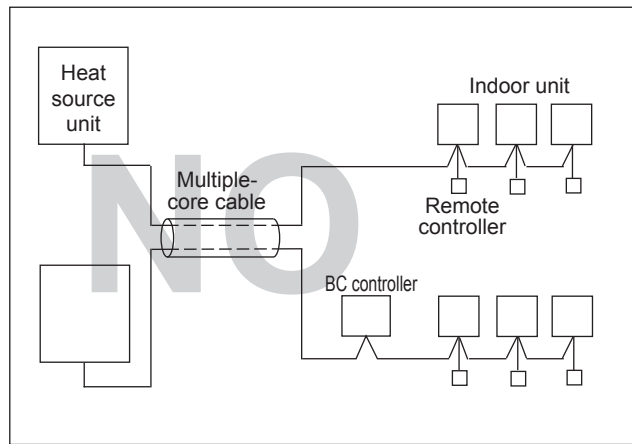
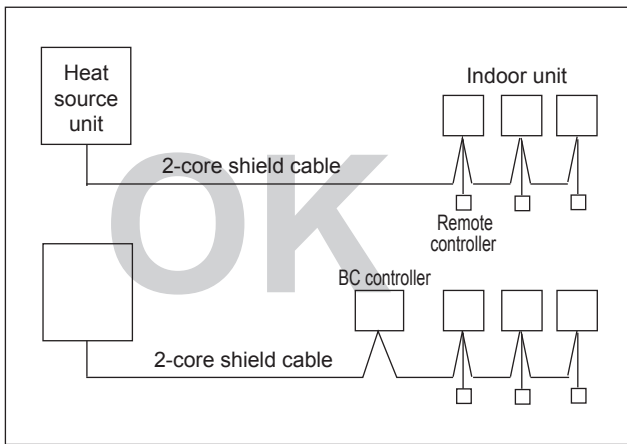

1-2. Power supply for Indoor unit and Heat source unit

1-2-1. Electrical characteristics of Indoor unit

Symbols: MCA: Minimum Circuit Ampacity (=1.25xFLA) FLA: Full Load Amps

IFM: Indoor Fan Motor Output: Fan motor rated output

Model	Indoor Unit			IFM		
	Hz	Volts	Voltage range	MCA(A)	Output(kW)	FLA(A)
PLFY-P08NCMU-E	60Hz	208 / 230V	198 to 253V	0.29 / 0.29	0.015 / 0.015	0.23 / 0.23
PLFY-P12NCMU-E				0.35 / 0.35	0.020 / 0.020	0.28 / 0.28
PLFY-P15NCMU-E				0.35 / 0.35	0.020 / 0.020	0.28 / 0.28
PLFY-P08NBMU-E2				0.39 / 0.39	0.050 / 0.050	0.31 / 0.31
PLFY-P12NBMU-E2				0.39 / 0.39	0.050 / 0.050	0.31 / 0.31
PLFY-P15NBMU-E2				0.39 / 0.39	0.050 / 0.050	0.31 / 0.31
PLFY-P18NBMU-E2				0.42 / 0.42	0.050 / 0.050	0.33 / 0.33
PLFY-P24NBMU-E2				0.59 / 0.59	0.050 / 0.050	0.47 / 0.47
PLFY-P30NBMU-E2				0.63 / 0.63	0.050 / 0.050	0.50 / 0.50
PLFY-P36NBMU-E2				1.09 / 1.09	0.120 / 0.120	0.87 / 0.87
PMFY-P06NBMU-E	60Hz	208 / 230V	198 to 253V	0.25 / 0.25	0.028 / 0.028	0.20 / 0.20
PMFY-P08NBMU-E				0.25 / 0.25	0.028 / 0.028	0.20 / 0.20
PMFY-P12NBMU-E				0.26 / 0.26	0.028 / 0.028	0.21 / 0.21
PMFY-P15NBMU-E				0.33 / 0.33	0.028 / 0.028	0.26 / 0.26
PEFY-P06NMAU-E3	60Hz	208 / 230V	188 to 253V	1.05 / 1.05	0.085 / 0.085	0.84 / 0.84
PEFY-P08NMAU-E3				1.05 / 1.05	0.085 / 0.085	0.84 / 0.84
PEFY-P12NMAU-E3				1.20 / 1.20	0.085 / 0.085	0.96 / 0.96
PEFY-P15NMAU-E3				1.45 / 1.45	0.085 / 0.085	1.16 / 1.16
PEFY-P18NMAU-E3				1.56 / 1.56	0.085 / 0.085	1.25 / 1.25
PEFY-P24NMAU-E3				2.73 / 2.73	0.121 / 0.121	2.18 / 2.18
PEFY-P27NMAU-E3				2.73 / 2.73	0.121 / 0.121	2.18 / 2.18
PEFY-P30NMAU-E3				2.73 / 2.73	0.121 / 0.121	2.18 / 2.18
PEFY-P36NMAU-E3				3.32 / 3.32	0.244 / 0.244	2.66 / 2.66
PEFY-P48NMAU-E3				3.41 / 3.41	0.244 / 0.244	2.73 / 2.73
PEFY-P54NMAU-E3				3.31 / 3.31	0.244 / 0.244	2.65 / 2.65
PEFY-P06NMSU-E				60Hz	208 / 230V	188 to 253V
PEFY-P08NMSU-E	0.47 / 0.50	0.023 / 0.023	0.41 / 0.39			
PEFY-P12NMSU-E	0.68 / 0.74	0.032 / 0.032	0.46 / 0.43			
PEFY-P15NMSU-E	1.20 / 1.33	0.130 / 0.130	0.47 / 0.45			
PEFY-P18NMSU-E	1.20 / 1.33	0.130 / 0.130	0.64 / 0.60			
PEFY-P24NMSU-E	1.57 / 1.73	0.180 / 0.180	0.88 / 0.83			
PEFY-P15NMHU-E2	1.63 / 1.50	0.17	1.30 / 1.20			
PEFY-P18NMHU-E2	1.63 / 1.50	0.17	1.30 / 1.20			
PEFY-P24NMHU-E2	2.11 / 1.83	0.25	1.69 / 1.46			
PEFY-P27NMHU-E2	2.35 / 2.13	0.26	1.88 / 1.70			
PEFY-P30NMHU-E2	2.70 / 2.45	0.31	2.16 / 1.96			
PEFY-P36NMHU-E2	4.16 / 3.67	0.49	3.32 / 2.94			
PEFY-P48NMHU-E2	4.16 / 3.67	0.49	3.32 / 2.94			
PEFY-P54NMHU-E2	4.18 / 3.69	0.55	3.34 / 2.95			
PEFY-P72NMHSU-E	7.7	0.87	6.2			
PEFY-P96NMHSU-E	8.2	0.87	6.6			

S.D. MY 575V

1. Electrical work

U11 2nd

Symbols: MCA: Minimum Circuit Ampacity (=1.25xFLA) FLA: Full Load Amps

IFM: Indoor Fan Motor

Output: Fan motor rated output

Model	Indoor Unit			IFM		
	Hz	Volts	Voltage range	MCA(A)	Output(kW)	FLA(A)
PCFY-P15NKMU-E	60Hz	208 / 230V	198 to 253V	0.44 / 0.44	0.090 / 0.090	0.35 / 0.35
PCFY-P24NKMU-E				0.52 / 0.52	0.095 / 0.095	0.41 / 0.41
PCFY-P30NKMU-E				1.22 / 1.22	0.160 / 0.160	0.97 / 0.97
PCFY-P36NKMU-E				1.22 / 1.22	0.160 / 0.160	0.97 / 0.97
PKFY-P06NBMU-E2	60Hz	208 / 230V	198 to 253V	0.19 / 0.19	0.008 / 0.008	0.15 / 0.15
PKFY-P08NHMU-E2				0.38 / 0.38	0.030 / 0.030	0.30 / 0.30
PKFY-P12NHMU-E2				0.38 / 0.38	0.030 / 0.030	0.30 / 0.30
PKFY-P15NHMU-E2				0.38 / 0.38	0.030 / 0.030	0.30 / 0.30
PKFY-P18NHMU-E2				0.38 / 0.38	0.030 / 0.030	0.30 / 0.30
PKFY-P24NKMU-E2				0.63 / 0.63	0.056 / 0.056	0.50 / 0.50
PKFY-P30NKMU-E2				0.63 / 0.63	0.056 / 0.056	0.50 / 0.50
PFFY-P06NEMU-E	60Hz	208 / 230V	188 to 253V	0.32 / 0.34	0.015 / 0.015	0.25 / 0.27
PFFY-P08NEMU-E				0.32 / 0.34	0.015 / 0.015	0.25 / 0.27
PFFY-P12NEMU-E				0.34 / 0.38	0.018 / 0.018	0.27 / 0.30
PFFY-P15NEMU-E				0.40 / 0.44	0.030 / 0.030	0.32 / 0.35
PFFY-P18NEMU-E				0.48 / 0.53	0.035 / 0.035	0.38 / 0.42
PFFY-P24NEMU-E				0.59 / 0.64	0.063 / 0.063	0.47 / 0.51
PFFY-P06NRMU-E	60Hz	208 / 230V	188 to 253V	0.32 / 0.34	0.015 / 0.015	0.25 / 0.27
PFFY-P08NRMU-E				0.32 / 0.34	0.015 / 0.015	0.25 / 0.27
PFFY-P12NRMU-E				0.34 / 0.38	0.018 / 0.018	0.27 / 0.30
PFFY-P15NRMU-E				0.40 / 0.44	0.030 / 0.030	0.32 / 0.35
PFFY-P18NRMU-E				0.48 / 0.53	0.035 / 0.035	0.38 / 0.42
PFFY-P24NRMU-E				0.59 / 0.64	0.063 / 0.063	0.47 / 0.51
PVFY-P12NAMU-E	60Hz	208 / 230V	188 to 253V	3.00 / 3.00	0.121 / 0.121	2.4 / 2.4
PVFY-P18NAMU-E				3.00 / 3.00	0.121 / 0.121	2.4 / 2.4
PVFY-P24NAMU-E				3.00 / 3.00	0.121 / 0.121	2.4 / 2.4
PVFY-P30NAMU-E				4.13 / 4.13	0.244 / 0.244	3.3 / 3.3
PVFY-P36NAMU-E				4.13 / 4.13	0.244 / 0.244	3.3 / 3.3
PVFY-P48NAMU-E				5.63 / 5.63	0.430 / 0.430	4.5 / 4.5
PVFY-P54NAMU-E				5.63 / 5.63	0.430 / 0.430	4.5 / 4.5

S.D. WY 575V

1-2-2. Electrical characteristics of Heat source unit at cooling mode

Symbols: MCA: Minimum Circuit Ampacity
 SC: Starting Current
 MOCP: Maximum Over Current Protection

PQHY-P-Z(S)KMU

Model	Unit Combination	Heat source unit						Compressor	
		Hz	Volts	Voltage range	MCA(A)	Max.CKT. BKR(A)	MOCP(A)	Output(kW)	SC(A)
PQHY-P72ZKMU-A	-	60Hz	575V	518 to 633V	9	15	15	4.3	7
PQHY-P96ZKMU-A	-				12	15	20	6.0	7
PQHY-P120ZKMU-A	-				13	20	22	7.7	7
PQHY-P144ZSKMU-A	PQHY-P72ZKMU-A				9	15	15	4.3	7
	PQHY-P72ZKMU-A				9	15	15	4.3	7
PQHY-P168ZSKMU-A	PQHY-P72ZKMU-A				9	15	15	4.3	7
	PQHY-P96ZKMU-A				12	15	20	6.0	7
PQHY-P192ZSKMU-A	PQHY-P96ZKMU-A				12	15	20	6.0	7
	PQHY-P96ZKMU-A				12	15	20	6.0	7
PQHY-P216ZSKMU-A	PQHY-P96ZKMU-A				12	15	20	6.0	7
	PQHY-P120ZKMU-A				13	20	22	7.7	7
PQHY-P240ZSKMU-A	PQHY-P120ZKMU-A				13	20	22	7.7	7
	PQHY-P120ZKMU-A				13	20	22	7.7	7
PQHY-P264ZSKMU-A	PQHY-P72ZKMU-A				9	15	15	4.3	7
	PQHY-P96ZKMU-A				12	15	20	6.0	7
	PQHY-P96ZKMU-A				12	15	20	6.0	7
PQHY-P288ZSKMU-A	PQHY-P96ZKMU-A				12	15	20	6.0	7
	PQHY-P96ZKMU-A				12	15	20	6.0	7
	PQHY-P96ZKMU-A				12	15	20	6.0	7
PQHY-P312ZSKMU-A	PQHY-P96ZKMU-A				12	15	20	6.0	7
	PQHY-P96ZKMU-A				12	15	20	6.0	7
	PQHY-P120ZKMU-A				13	20	22	7.7	7
PQHY-P336ZSKMU-A	PQHY-P96ZKMU-A				12	15	20	6.0	7
	PQHY-P120ZKMU-A				13	20	22	7.7	7
	PQHY-P120ZKMU-A	13	20	22	7.7	7			
PQHY-P360ZSKMU-A	PQHY-P120ZKMU-A	13	20	22	7.7	7			
	PQHY-P120ZKMU-A	13	20	22	7.7	7			
	PQHY-P120ZKMU-A	13	20	22	7.7	7			

S.D. WY 575V

1-3. Power cable specifications

Thickness of wire for main power supply, capacities of the switch and system impedance

	Model	Minimum wire thickness (mm ² /AWG)			Breaker for current leakage	Local Switch (A)		Breaker for wiring (NFB)
		Main cable	Branch	Ground		Capacity	Fuse	
Heat source unit	PQHY-P72ZKMU-A	2.1/14	-	2.1/14	15A 30mA or 100mA 0.1sec. or less	15	15	15
	PQHY-P96ZKMU-A	2.1/14	-	2.1/14	15A 30mA or 100mA 0.1sec. or less	15	15	15
	PQHY-P120ZKMU-A	3.3/12	-	3.3/12	20A 30mA or 100mA 0.1sec. or less	20	20	20
Total operating current of the indoor unit	F0 = 15 or less *1	2.1/14	2.1/14	2.1/14	15A current sensitivity *2	15	15	15
	F0 = 20 or less *1	3.3/12	3.3/12	3.3/12	20A current sensitivity *2	20	20	20
	F0 = 30 or less *1	5.3/10	5.3/10	5.3/10	30A current sensitivity *2	30	30	30

*1 Please take the larger of F1 or F2 as the value for F0.

F1 = Total operating maximum current of the indoor units × 1.2

F2 = {V1 × (Quantity of Type1)/C} + {V1 × (Quantity of Type2)/C} + {V1 × (Quantity of Type3)/C} + {V1 × (Quantity of Others)/C}

Indoor unit		V1	V2
Type1	PLFY-NBMU, PMFY-NBMU, PEFY-NMSU, PCFY-NKMU, PKFY-NHMU, PKFY-NKMU	18.6	2.4
Type2	PEFY-NMAU	38	1.6
Type3	PEFY-NMHSU	13.8	4.8
Others	Other indoor unit	0	0

C : Multiple of tripping current at tripping time 0.01s

Please pick up "C" from the tripping characteristic of the breaker.

<Example of "F2" calculation>

*Condition PEFY-NMSU × 4 + PEFY-NMAU × 1, C = 8 (refer to right sample chart)

F2 = 18.6 × 4/8 + 38 × 1/8

= 14.05

→16 A breaker (Tripping current = 8 × 16 A at 0.01s)

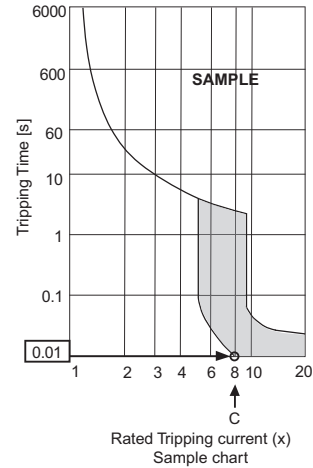

*2 Current sensitivity is calculated using the following formula.

G1 = (V2 × Quantity of Type1) + (V2 × Quantity of Type2) + (V2 × Quantity of Type3) + (V2 × Quantity of Others) + (V3 × Wire length [km])

G1	Current sensitivity
30 or less	30 mA 0.1sec or less
100 or less	100 mA 0.1sec or less

Wire thickness	V3
1.5 mm ²	48
2.5 mm ²	56
4.0 mm ²	66

- Use dedicated power supplies for the heat source unit and indoor unit. Ensure OC and OS are wired individually.
- Bear in mind ambient conditions (ambient temperature, direct sunlight, rain water, etc.) when proceeding with the wiring and connections.
- The wire size is the minimum value for metal conduit wiring. If the voltage drops, use a wire that is one rank thicker in diameter. Make sure the power-supply voltage does not drop more than 10%. Make sure that the voltage imbalance between the phases is 2% or less.
- Specific wiring requirements should adhere to the wiring regulations of the region.
- Power supply cords of parts of appliances for heat source use shall not be lighter than polychloroprene sheathed flexible cord (design 245 IEC57). For example, use wiring such as YZW.
- A switch with at least 3 mm [1/8 in.] contact separation in each pole shall be provided by the Air Conditioner installer.

⚠ WARNING

- Be sure to use specified wires for connections and ensure no external force is imparted to terminal connections. If connections are not fixed firmly, heating or fire may result.
- Be sure to use the appropriate type of overcurrent protection switch. Note that generated overcurrent may include some amount of direct current.

⚠ CAUTION

- The breakers for current leakage should support Inverter circuit. (e.g. Mitsubishi Electric's NV-C series or equivalent). If no earth leakage breaker is installed, it may cause an electric shock.
- Breakers for current leakage should combine using of switch.
- Do not use anything other than a breaker with the correct capacity. Using a breaker of too large capacity may cause malfunction or fire.
- If a large electric current flows due to malfunction or faulty wiring, earth-leakage breakers on the unit side and on the upstream side of the power supply system may both operate. Depending on the importance of the system, separate the power supply system or take protective coordination of breakers.

S.D. WY 575V

1-4. Power supply examples

The local standards and/or regulations is applicable at a higher priority.

1-4-1. PQHY-P72, 96, 120ZKMU

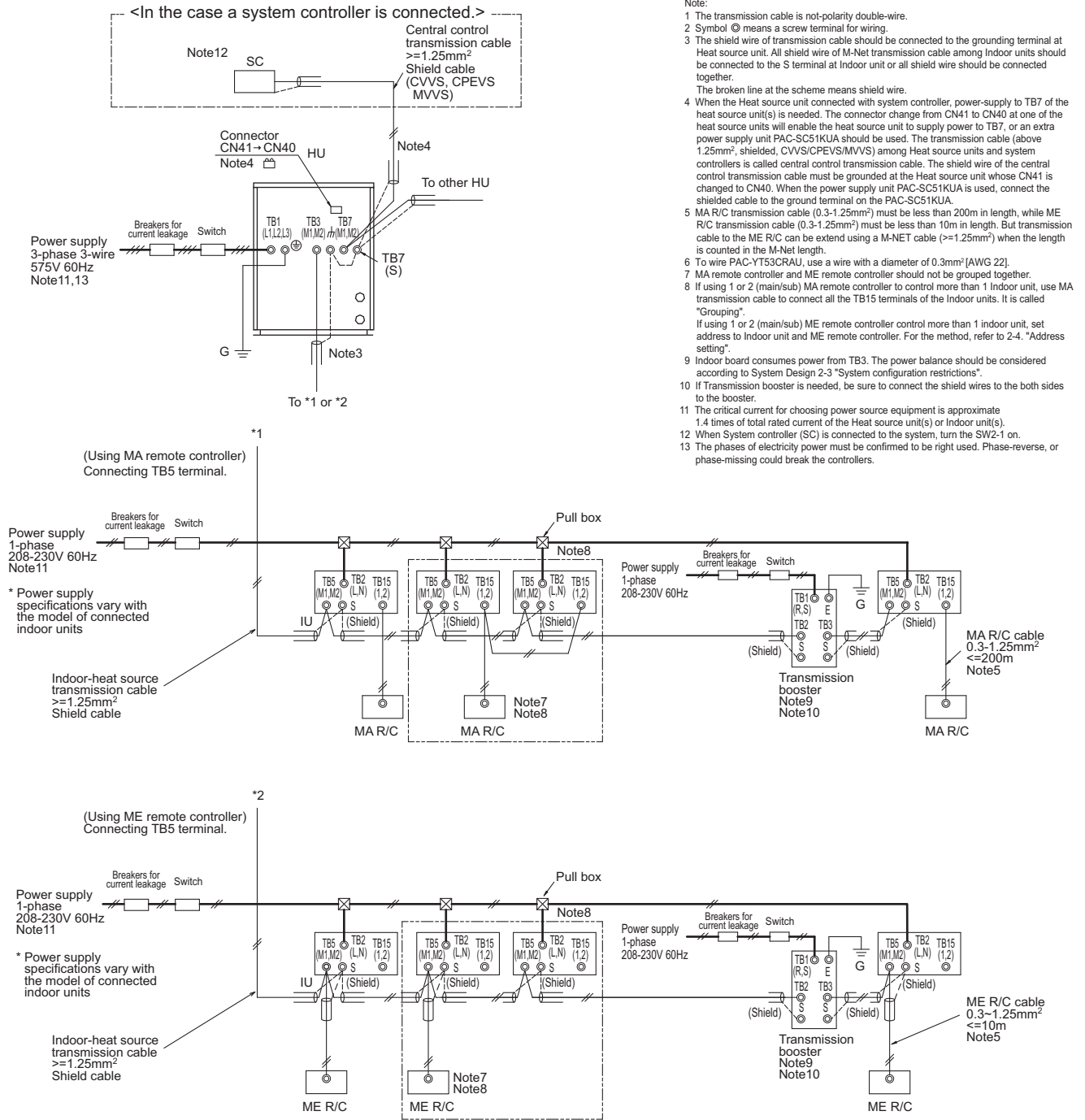

Symbol	Model	Breakers for current leakage *1, *2, *4	Switch		Switch*4 (NFB) <A>	Minimum Wire thickness	
			BKC <A>	OCP*3, *4 <A>		Power wire <mm ² /AWG>	G wire <mm ² /AWG>
BKC	Breaker capacity	PQHY-P72ZKMU	15A 30mA or 100mA 0.1sec. or less	15	15	2.1/14	2.1/14
OCP	Over-current protector	PQHY-P96ZKMU	15A 30mA or 100mA 0.1sec. or less	15	15	2.1/14	2.1/14
NFB	Non-fuse breaker	PQHY-P120ZKMU	20A 30mA or 100mA 0.1sec. or less	20	20	3.3/12	3.3/12

- *1 The breakers for current leakage should support Inverter circuit. (e.g. Mitsubishi Electric's NV-C series or equivalent).
- *2 Breakers for current leakage should combine using of switch.
- *3 It shows data for B-type fuse of the breaker for current leakage.
- *4 If a large electric current flows due to malfunction or faulty wiring, earth-leakage breakers on the unit side and on the centralized controller side may both operate.
Depending on the importance of the system, separate the power supply system or take protective coordination of breakers.

S.D. WY 575V

The local standards and/or regulations is applicable at a higher priority.
1-4-2. PQHY-P144, 168, 192, 216, 240ZSKMU

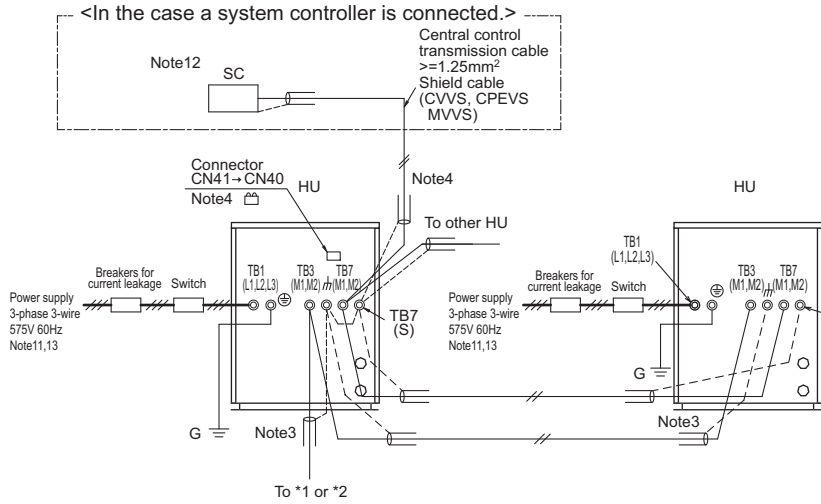

- Note:
- The transmission cable is not-polarity double-wire.
 - Symbol Ⓞ means a screw terminal for wiring.
 - The shield wire of transmission cable should be connected to the grounding terminal at Heat source unit. All shield wire of M-Net transmission cable among Indoor units should be connected to the S terminal at Indoor unit or all shield wire should be connected together. The broken line at the scheme means shield wire.
 - When the Heat source unit connected with system controller, power-supply to TB7 of the heat source unit(s) is needed. The connector change from CN41 to CN40 at one of the heat source units will enable the heat source unit to supply power to TB7, or an extra power supply unit PAC-SC51KUA should be used. The transmission cable (above 1.25mm², shielded, CVVS/CPEVS/MVVS) among Heat source units and system controllers is called central control transmission cable. The shield wire of the central control transmission cable must be grounded at the Heat source unit whose CN41 is changed to CN40. When the power supply unit PAC-SC51KUA is used, connect the shielded cable to the ground terminal on the PAC-SC51KUA.
 - MA R/C transmission cable (0.3-1.25mm²) must be less than 200m in length, while ME R/C transmission cable (0.3-1.25mm²) must be less than 10m in length. But transmission cable to the ME R/C can be extended using a M-NET cable (>=1.25mm²) when the length is counted in the M-Net length.
 - To wire PAC-YT53CRAU, use a wire with a diameter of 0.3mm² [AWG 22].
 - MA remote controller and ME remote controller should not be grouped together.
 - If using 1 or 2 (main/sub) MA remote controller to control more than 1 Indoor unit, use MA transmission cable to connect all the TB15 terminals of the Indoor units. It is called "Grouping". If using 1 or 2 (main/sub) ME remote controller control more than 1 indoor unit, set address to Indoor unit and ME remote controller. For the method, refer to 2-4. "Address setting".
 - Indoor board consumes power from TB3. The power balance should be considered according to System Design 2-3 "System configuration restrictions".
 - If Transmission booster is needed, be sure to connect the shield wires to the both sides to the booster.
 - The critical current for choosing power source equipment is approximate 1.4 times of total rated current of the Heat source unit(s) or Indoor unit(s).
 - When System controller (SC) is connected to the system, turn the SW2-1 on.
 - The phases of electricity power must be confirmed to be right used. Phase-reverse, or phase-missing could break the controllers.

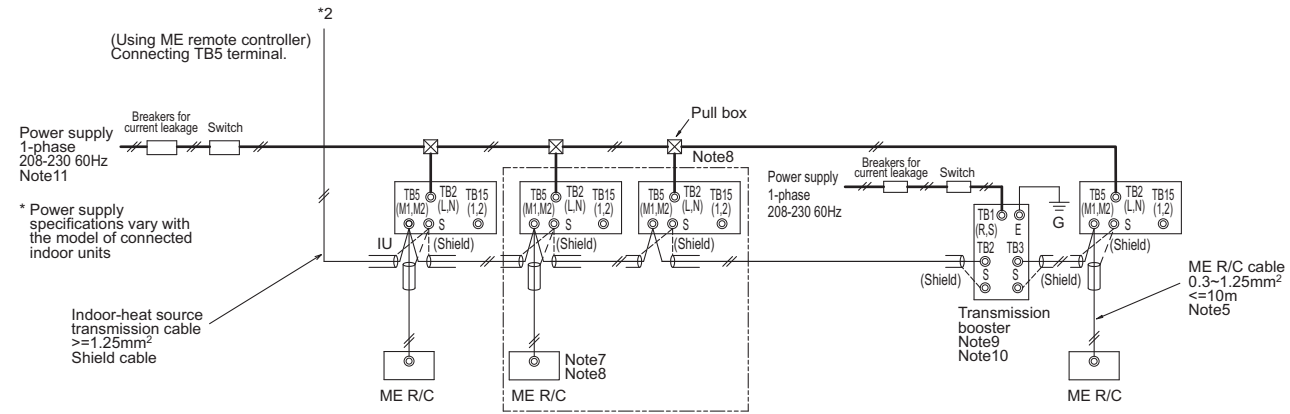
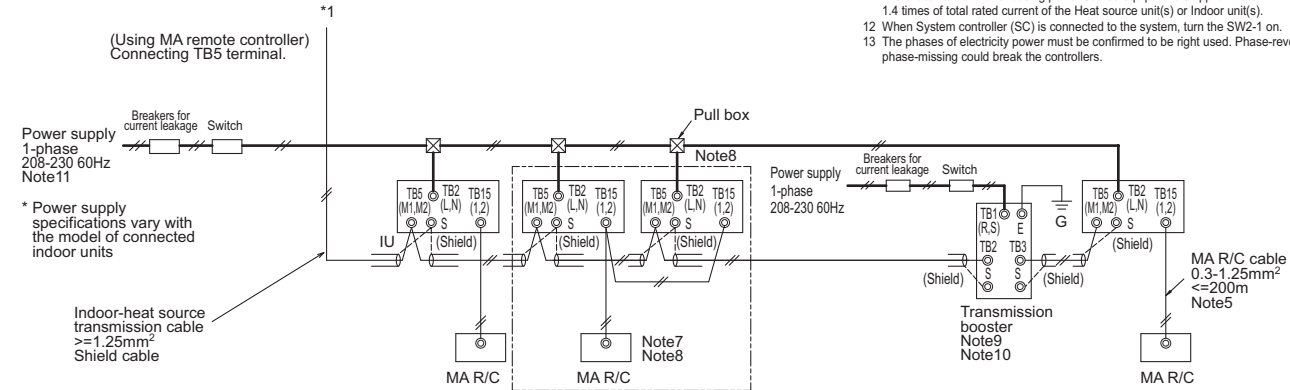

Symbol	Model	Breakers for current leakage *1, *2, *4	Switch		Switch*4 (NFB)	Minimum Wire thickness	
			BKC <A>	OCP*3, *4 <A>		Power wire <mm ² /AWG>	G wire <mm ² /AWG>
BKC	PQHY-P72ZKMU	15A 30mA or 100mA 0.1sec. or less	15	15	15	2.1/14	2.1/14
OCP	PQHY-P96ZKMU	15A 30mA or 100mA 0.1sec. or less	15	15	15	2.1/14	2.1/14
NFB	PQHY-P120ZKMU	20A 30mA or 100mA 0.1sec. or less	20	20	20	3.3/12	3.3/12

*1 The breakers for current leakage should support Inverter circuit. (e.g. Mitsubishi Electric's NV-C series or equivalent).
*2 Breakers for current leakage should combine using of switch.
*3 It shows data for B-type fuse of the breaker for current leakage.
*4 If a large electric current flows due to malfunction or faulty wiring, earth-leakage breakers on the unit side and on the centralized controller side may both operate.
Depending on the importance of the system, separate the power supply system or take protective coordination of breakers.

S.D. WY 575V

The local standards and/or regulations is applicable at a higher priority.
 1-4-3. PQHY-P264, 288, 312, 336, 360ZSKMU

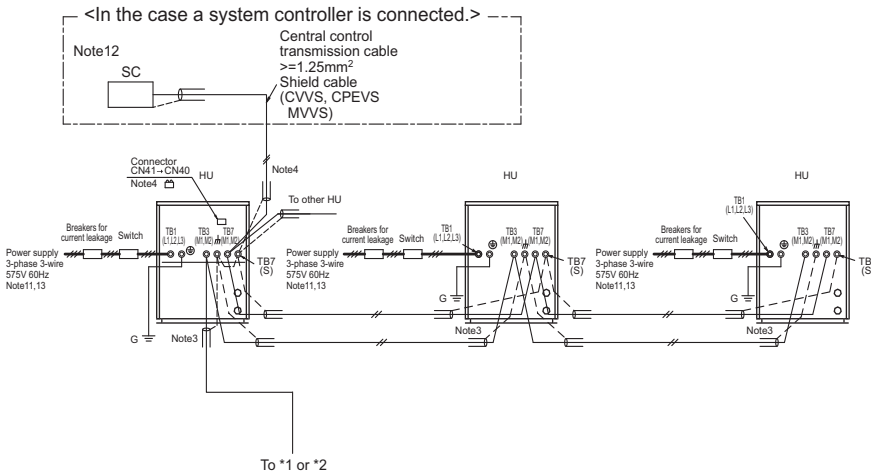

- Note:
- The transmission cable is not-polarity double-wire.
 - Symbol © means a screw terminal for wiring.
 - The shield wire of transmission cable should be connected to the grounding terminal at Heat source unit. All shield wire of M-Net transmission cable among Indoor units should be connected to the S terminal at Indoor unit or all shield wire should be connected together.
The broken line at the scheme means shield wire.
 - When the Heat source unit connected with system controller, power-supply to TB7 of the heat source unit(s) is needed. The connector change from CN41 to CN40 at one of the heat source units will enable the heat source unit to supply power to TB7, or an extra power supply unit PAC-SC51KUA should be used. The transmission cable (above 1.25mm², shielded, CVVS/CPEVS/MVVS) among Heat source units and system controllers is called central control transmission cable. The shield wire of the central control transmission cable must be grounded at the Heat source unit whose CN41 is changed to CN40. When the power supply unit PAC-SC51KUA is used, connect the shielded cable to the ground terminal on the PAC-SC51KUA.
 - MA R/C transmission cable (0.3-1.25mm²) must be less than 200m in length, while ME R/C transmission cable (0.3-1.25mm²) must be less than 10m in length. But transmission cable to the ME R/C can be extended using a M-NET cable (>=1.25mm²) when the length is counted in the M-Net length.
 - To wire PAC-YT53CRAU, use a wire with a diameter of 0.3mm² [AWG 22].
 - MA remote controller and ME remote controller should not be grouped together.
 - If using 1 or 2 (main/sub) MA remote controller to control more than 1 Indoor unit, use MA transmission cable to connect all the TB15 terminals of the Indoor units. It is called "Grouping".
If using 1 or 2 (main/sub) ME remote controller control more than 1 indoor unit, set address to Indoor unit and ME remote controller. For the method, refer to 2-4. "Address setting".
 - Indoor board consumes power from TB3. The power balance should be considered according to System Design 2-3 "System configuration restrictions".
 - If Transmission booster is needed, be sure to connect the shield wires to the both sides to the booster.
 - The critical current for choosing power source equipment is approximate 1.4 times of total rated current of the Heat source unit(s) or Indoor unit(s).
 - When System controller (SC) is connected to the system, turn the SW2-1 on.
 - The phases of electricity power must be confirmed to be right used. Phase-reverse, or phase-missing could break the controllers.

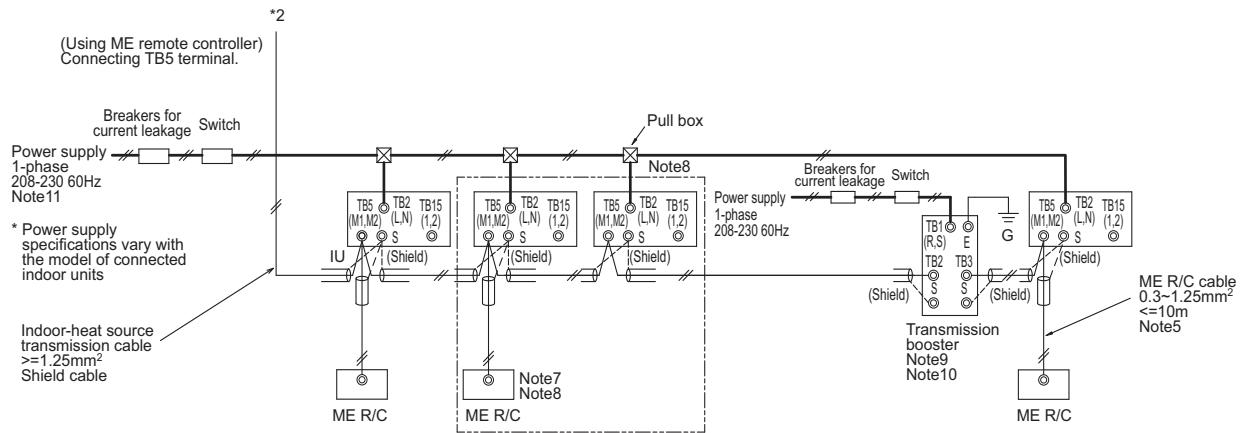
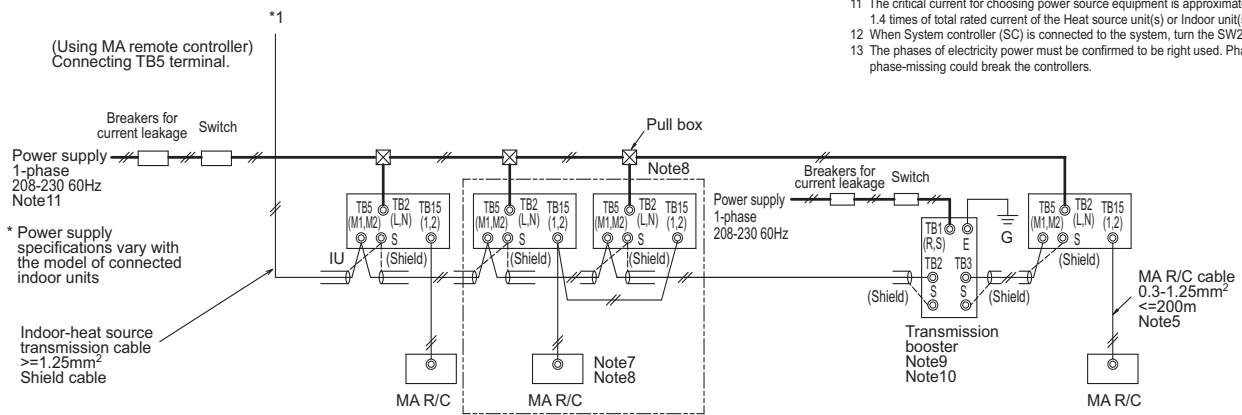

Symbol	Model	Breakers for current leakage *1, *2, *4	Switch			Minimum Wire thickness		
			BKC <A>	OCP*3, *4 <A>	Switch*4 (NFB) <A>	Power wire <mm ² /AWG>	G wire <mm ² /AWG>	
BKC	Breaker capacity	PQHY-P72ZKMU	15A 30mA or 100mA 0.1sec. or less	15	15	15	2.1/14	2.1/14
OCP	Over-current protector	PQHY-P96ZKMU	15A 30mA or 100mA 0.1sec. or less	15	15	15	2.1/14	2.1/14
NFB	Non-fuse breaker	PQHY-P120ZKMU	20A 30mA or 100mA 0.1sec. or less	20	20	20	3.3/12	3.3/12

- *1 The breakers for current leakage should support Inverter circuit. (e.g. Mitsubishi Electric's NV-C series or equivalent).
 *2 Breakers for current leakage should combine using of switch.
 *3 It shows data for B-type fuse of the breaker for current leakage.
 *4 If a large electric current flows due to malfunction or faulty wiring, earth-leakage breakers on the unit side and on the centralized controller side may both operate.
 Depending on the importance of the system, separate the power supply system or take protective coordination of breakers.

S.D. WY 575V

2-1. Transmission cable length limitation

2-1-1. Using MA Remote controller

MA remote controller refers to Simple MA remote controller and wireless remote controller.

Long transmission cable causes voltage down, therefore, the length limitation should be obeyed to secure proper transmission.

Max. length via Heat source (M-NET cable)	$L_1+L_2+L_3, L_1+L_2+L_4+L_5, L_3+L_4+L_5, L_6+L_2+L_3, L_6+L_2+L_4+L_5$	$\leq 500\text{m}[1640\text{ft.}]$	1.25mm ² [AWG16] or thicker
Max. length to Heat source (M-NET cable)	$L_1+L_6, L_3, L_2+L_4+L_6, L_5$	$\leq 200\text{m}[656\text{ft.}]$	1.25mm ² [AWG16] or thicker
Max. length from MA to Indoor for each group	$a_1+a_2, a_1+a_2+a_3+a_4$	$\leq 200\text{m}[656\text{ft.}]$	0.3-1.25 mm ² [AWG22-16]
24VDC to AG-150A-A	n	$\leq 50\text{m}[164\text{ft.}]$	0.75-2.0 mm ² [AWG18-14]

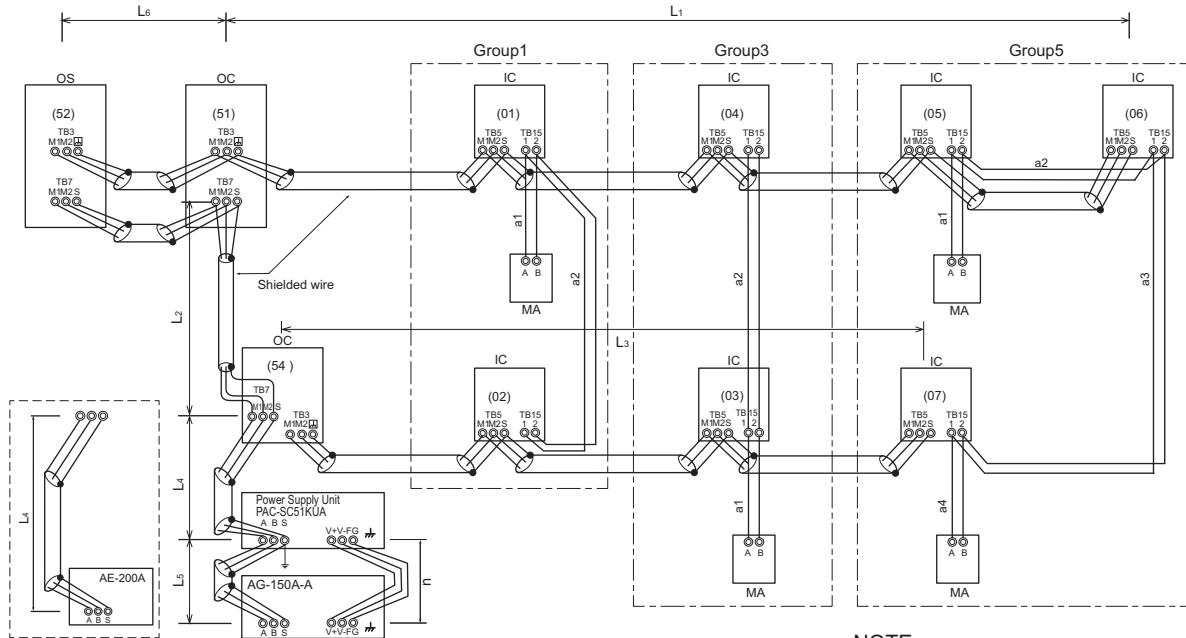

OC, OS: Heat source unit controller; IC: Indoor unit controller; MA: MA remote controller

NOTE
Do not daisy-chain remote controllers.

2-1-2. Using ME Remote controller

ME remote controller refers to Smart ME Controller.

Long transmission cable causes voltage down, therefore, the length limitation should be obeyed to secure proper transmission.

Max. length via Heat source (M-NET cable)	$L_1+L_2+L_3+L_4, L_1+L_2+L_6+L_7, L_1+L_2+L_3+L_5, L_3+L_4+L_6+L_7, L_8+L_2+L_3+L_4, L_8+L_2+L_3+L_5, L_8+L_2+L_6+L_7$	$\leq 500\text{m}[1640\text{ft.}]$	1.25mm ² [AWG16] or thicker
Max. length to Heat source (M-NET cable)	$L_1+L_8, L_3+L_4, L_2+L_6+L_8, L_7, L_3+L_5$	$\leq 200\text{m}[656\text{ft.}]$	1.25mm ² [AWG16] or thicker
Max. length from ME to Indoor	e_1, e_2+e_3, e_4	$\leq 10\text{m}[32\text{ft.}]^*1$	0.3-1.25 mm ² [AWG22-16]^*1
24VDC to AG-150A-A	n	$\leq 50\text{m}[164\text{ft.}]$	0.75-2.0 mm ² [AWG18-14]

*1. If the length from ME to Indoor exceed 10m, use 1.25 mm² [AWG16] shielded cable, but the total length should be counted into Max. length via Heat source.

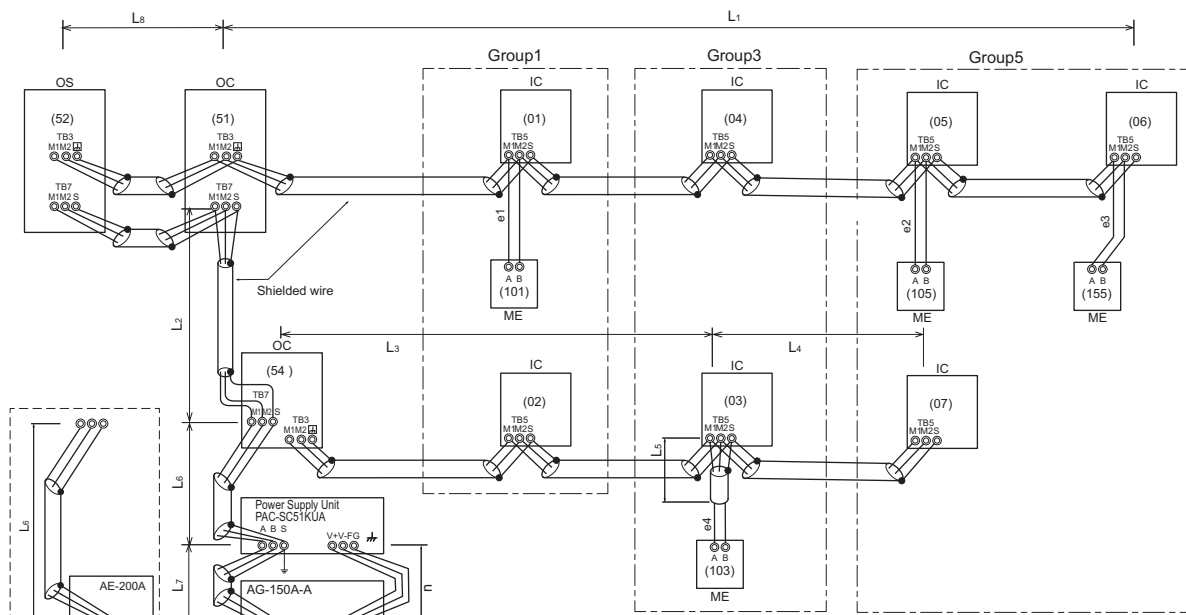

OC, OS: Heat source unit controller; IC: Indoor unit controller; ME: ME remote controller

NOTE
Do not daisy-chain remote controllers.

S.D. WY 575V

2-2. Transmission cable specifications

	Transmission cables (Li)	ME Remote controller cables	MA Remote controller cables
Type of cable	Shielding wire (2-core) CVVS, CPEVS or MVVS	Sheathed 2-core cable (unshielded) CVV	
Cable size	More than 1.25mm ² [AWG16]	0.3~1.25mm ² [AWG22~16]	0.3~1.25mm ² [AWG22~16]*1
Remarks	—	When 10m [32ft] is exceeded, use cables with the same specification as transmission cables.	Max length : 200m [656ft]

*1 To wire PAC-YT53CRAU, use a wire with a diameter of 0.3 mm² [AWG22]

CVVS, MVVS: PVC insulated PVC sheathed shielded control cable
CPEVS: PE insulated PVC sheathed shielded communication cable
CVV: PVC insulated PVC sheathed control cable

2-3. System configuration restrictions

2-3-1. Common restrictions for the CITYMULTI system

For each Outdoor/Heat source unit, the maximum connectable quantity of Indoor unit is specified at its Specifications table.

- A) 1 Group of Indoor units can have 1-16 Indoor units;
- B) Maximum 2 remote controllers for 1 group;
 - *MA/ME remote controllers cannot be present together in 1group.
 - *To wire PAC-YT53CRAU, use a wire with a diameter of 0.3 mm² [AWG22]
- C) 1 LOSSNAY unit can interlock maximum 16 Indoor units; 1 Indoor unit can interlock only 1 LOSSNAY unit.
- D) Maximum 3 System controllers are connectable when connecting to TB3 of the Outdoor/Heat source unit.
- E) Maximum 6 System controllers are connectable when connecting to TB7 of the Outdoor/Heat source unit, if the transmission power is supplied by the Outdoor/Heat source unit.
 - (Not applicable to the PUMY model and PUHY/PURY-TLMU/TKMU model)
- F) 4 System controllers or more are connectable when connecting to TB7 of the Outdoor/Heat source unit, if the transmission power is supplied by the power supply unit PAC-SC51KUA. Details refer to 2-3-3-C.
 - *System controller connected as described in D) and E) would have a risk that the failure of connected Outdoor/Heat source unit would stop power supply to the System controller.

2-3-2. Ensuring proper communication power and the number of connected units for M-NET

In order to ensure proper communication among Outdoor/Heat source unit, Indoor unit, LOSSNAY, and Controllers, the transmission power situation for the M-NET should be observed. In some cases, Transmission booster should be used. Taking the power consumption of Indoor unit sized P06-P54 as 1, the equivalent power consumption or supply of others are listed at Table 1 and Table 2.

Both the transmission line for centralized controller and indoor-outdoor transmission line must meet the conditions listed below. (Both conditions a) and b) must be met.)

- a) [Total equivalent power consumption] ≤ [The equivalent power supply]
- b) [Total equivalent number of units] ≤ [40]

Table 1 The equivalent power consumption and the equivalent number of units

Category	Model	The equivalent power consumption	The equivalent number of units
Indoor unit	Sized P06-P54	1	1
	Sized P72, P96	2	2
BC controller	CMB	2	1
PWFY	P36NMU-E-BU	6	1
	P36NMU-E2-AU	1	1
	P72NMU-E2-AU	5	1
MA remote controller/LOSSNAY	PAC-YT53CRAU PAR-FA32MA LGH-F-RX5-E1 PZ-60DR-E PZ-41SLB PZ-52SF	0	0
ME remote controller	PAR-U01MEDU PAC-IF01AHC-J	0.5	1
System controller	AE-200A AE-50A EW-50A	0	0
	AG-150A-A EB-50GU-A	0.5	1
	TC-24B	1.5	5
	PAC-YG60MCA PAC-YG66DCA PAC-YG63MCA	0.25	1
ON/OFF controller	PAC-YT40ANRA	1	1
MN converter	CMS-MNG-E	2	1
Outdoor/Heat source unit	TB7 power consumption	0	0
M-NET adapter	MAC-333IF-E	0	0
	PAC-IF01MNT-E	1	2

Table 2 The equivalent power supply

Category	Model	The equivalent power supply
Transmission Booster	PAC-SF46EPA	25
Power supply unit	PAC-SC51KUA	5
Expansion controller	PAC-YG50ECA	6
BM ADAPTER	BAC-HD150	6
System controller	AE-200A/AE-50A	0 *1
	EW-50A	1.5 *1
Outdoor/Heat source unit	Connector TB3 and TB7 total *	32 (except S series)/12 (S series)
	Connector TB7 only	6 (except S series and TLMU/TKMU)
	Connector TB7 only (TLMU/TKMU)	0

*If PAC-SC51KUA is used to supply power at TB7 side, no power supply need from Outdoor/Heat source unit at TB7, Connector TB3 itself will therefore have 32. Not applicable to the PUMY model.

*1 AE-200A/AE-50A/EW-50A has a built-in function to supply power to the M-NET transmission line. The amount of power that an AE-200A or an AE-50A can supply is equivalent to the power required by an MN converter (CMS-MNG-E) that is used for maintenance. An MN converter is connectable to EW-50A only when the equivalent power consumption is less than 1.5.

With the equivalent power consumption values and the equivalent number of units in Table 1 and Table 2, PAC-SF46EPA can be designed into the air-conditioner system to ensure proper system communication according to (A), (B), (C).

- (A) Firstly, count from TB3 at TB3 side the total equivalent number of units of Indoor units, ME remote controller, and System controllers. If the total equivalent number of units reaches 40, a PAC-SF46EPA should be set. In this case, Indoor units sized P72 and 96 are counted as 2, TC-24B is counted as 5, but MA remote controller(s), PZ-60DR-E, PZ-41SLB, and PZ-52SF are NOT counted.
- (B) Secondly, count from TB7 side to TB3 side the total transmission power consumption. If the total power consumption reaches 32, a PAC-SF46EPA should be set. Yet, if a PAC-SC51KUA or another controller with a built-in power supply, such as PAC-YG50ECA, is used to supply power at TB7 side, count from TB3 side only.
- (C) Thirdly, count from TB7 at TB7 side the total transmission power consumption, If the total power consumption reaches 6, a PAC-SF46EPA should be set. Also, count from TB7 at TB7 side the total equivalent number of units of System controllers, and so on. If the total equivalent number of units reaches 40, a PAC-SF46EPA should be set.

■ System example

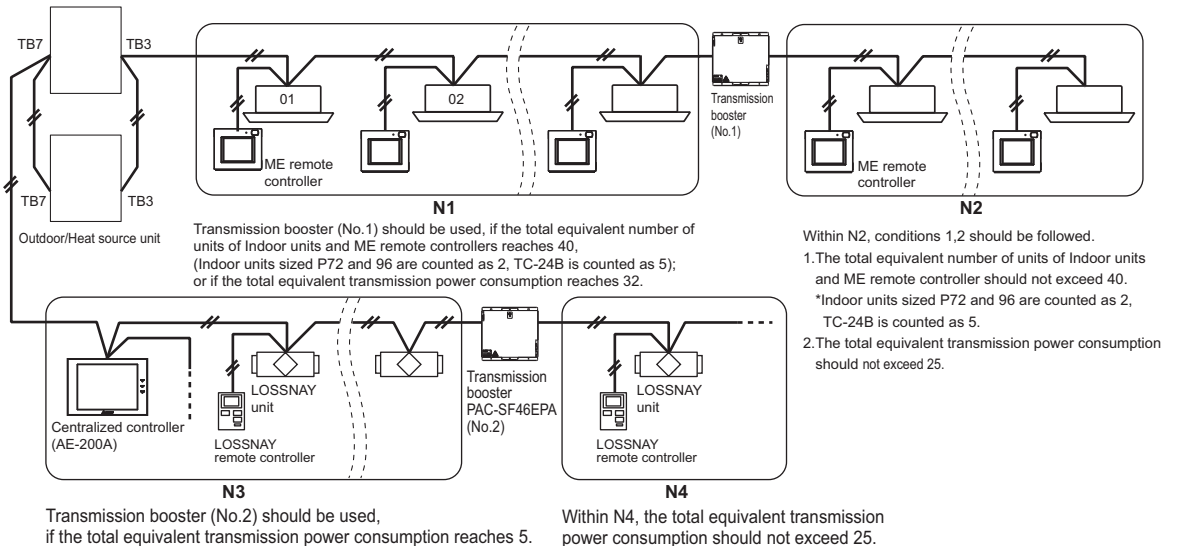

S.D. WY 575V

2-3-3. Ensuring proper power supply to System controller

The power to System controller (excluding AE-200A, AE-50A, EW-50A, BAC-HD150, LM-AP) is supplied via M-NET transmission line. M-NET transmission line at TB7 side is called Centralized control transmission line while one at TB3 side is called Indoor-Outdoor/Heat source transmission line. There are 3 ways to supply power to the System controller .

- A) Connecting to TB3 of the Outdoor/Heat source unit and receiving power from the Outdoor/Heat source unit.
- B) Connecting to TB7 of the Outdoor/Heat source unit and receiving power from the Outdoor/Heat source unit. (Not applicable to the PUMY model and PUHY/PURY-TLMU/TKMU model)
- C) Connecting to TB7 of the Outdoor/Heat source unit but receiving power from power supply unit PAC-SC51KUA.
 - * System controllers (AE-200A, AE-50A, EW-50A, BAC-HD150, LM-AP) have a built-in function to supply power to the M-NET transmission lines, so no power needs to be supplied to the M-NET transmission lines from the Outdoor/Heat source units or from PAC-SC51KUA.

2-3-3-A. When connecting to TB3 of the Outdoor/Heat source unit and receiving power from the Outdoor/Heat source unit.

Maximum 3 System controllers can be connected to TB3. If there is more than 1 Outdoor/Heat source unit, it is necessary to replace power supply switch connector CN41 with CN40 on one Outdoor/Heat source unit.

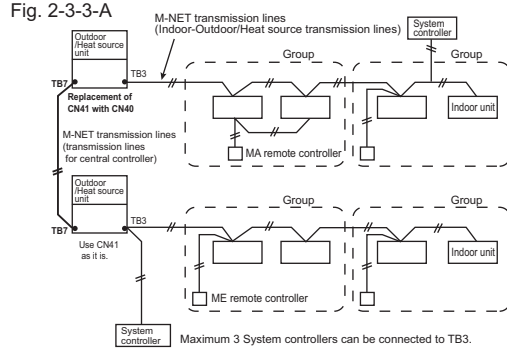

2-3-3-B. When connecting to TB7 of the Outdoor/Heat source unit and receiving power from the Outdoor/Heat source unit. (Not applicable to the PUMY model and PUHY/PURY-TLMU/TKMU model)

Maximum 6 System controllers can be connected to TB7 and receiving power from the Outdoor/Heat source unit. (Not applicable to the PUMY model and PUHY/PURY-TLMU/TKMU model) It is necessary to replace power supply switch connector CN41 with CN40 on one Outdoor/Heat source unit.

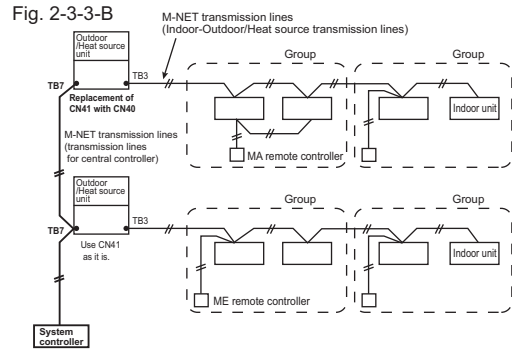

Note (only for PUHY/PURY model)

- When YLMU/YKMU Outdoor unit model is used, the male power supply connector can be connected to CN40, and the System controller can be connected to TB7 side.
- When the male power supply connector is connected from TLMU/TKMU Outdoor unit to CN40, the power is supplied to TB7 side even when the main power of the TLMU/TKMU outdoor unit is switched off, and the System controller may store an error in the error history and emit an alarm signal.
- If only LOSSNAY units or outdoor units in different refrigerant circuits are connected to TB7 side, the male power supply connector can be connected from TLMU/TKMU outdoor unit to CN40.

2-3-3-C. When connecting to TB7 of the Outdoor/Heat source unit but receiving power from PAC-SC51KUA.

When using PAC-SC51KUA to supply transmission power, the power supply connector CN41 on the Outdoor/Heat source units should be kept as it is. It is also a factory setting. 1 PAC-SC51KUA supports maximum 1 AG-150A-A or 1 EB-50GU-A unit due to the limited power 24VDC at its TB3. However, 1 PAC-SC51KUA supplies transmission power at its TB2 equal to 5 Indoor units, which is referable at Table 2. If PZ-52SF, System controller, ON/OFF controller connected to TB7 consume transmission power more than 5 (Indoor units), Transmission booster PAC-SF46EPA is needed. PAC-SF46EPA supplies transmission power equal to 25 Indoor units.

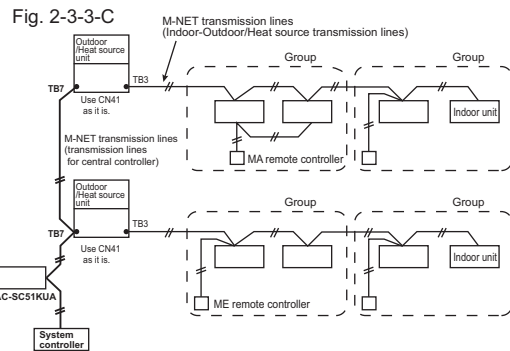

CAUTION

- AG-150A-A/EB-50GU-A*1 are recommended to connect to TB7 because it performs back-up to a number of data. In an air conditioner system has more than 1 Outdoor/Heat source units, AG-150A-A/EB-50GU-A receiving transmission power through TB3 or TB7 on one of the Outdoor/Heat source units would have a risk that the connected Outdoor/Heat source unit failure would stop power supply to AG-150A-A/EB-50GU-A and disrupt the whole system. When applying apportioned electric power function, AG-150A-A/EB-50GU-A are necessary to connected to TB7 and has its own power supply unit PAC-SC51KUA. Note: Power supply unit PAC-SC51KUA is for AG-150A-A/EB-50GU-A. *1: AG-150A-A is an example model of system controllers.
- How to connect system controllers (AE-200A, AE-50A, EW-50A, BAC-HD150, LM-AP) to a given system System controllers (AE-200A, AE-50A, EW-50A, BAC-HD150, LM-AP) have a built-in function to supply power to the M-NET transmission lines, so no power needs to be supplied to the M-NET transmission lines from the Outdoor/Heat source units or from PAC-SC51KUA. Leave the power supply connector on the Outdoor/Heat source unit connected to CN41 as it is. Refer to 2-3-2 for information about the power-supply capacity of each system controller (EW-50A, BAC-HD150, LM-AP) to the low-level system controllers.

Fig. 2-3-3-D

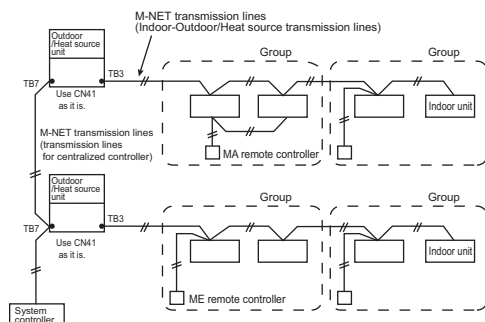

S.D. WY 575V

2-3-4. Power supply to LM-AP

1-phase 208-230V AC power supply is needed.

The power supply unit PAC-SC51KUA is not necessary when connecting only the LM-AP. Yet, make sure to change the power supply changeover connector CN41 to CN40 on the LM-AP.

2-3-5. Power supply to expansion controller

1-phase 100-240VAC power supply is needed.

The power supply unit PAC-SC51KUA is not necessary.

The expansion controller supplies power through TB3, which equals 6 indoor units. (refer to Table 2)

2-3-6. Power supply to BM ADAPTER

1-phase 100-240VAC power supply is needed.

The power supply unit PAC-SC51KUA is not necessary when only BM ADAPTER is connected.

Yet, make sure to move the power jumper from CN41 to CN40 on the BM ADAPTER.

2-3-7. Power supply to AE-200A/AE-50A/EW-50A

1-phase 100-240VAC power supply is needed.

The power supply unit PAC-SC51KUA is not necessary when connecting only the AE-200A/AE-50A/EW-50A.

2-4. Address setting

2-4-1. Switch operation

In order to constitute CITY MULTI in a complete system, switch operation for setting the unit address No. and connection No. is required.

① Address No. of heat source unit, indoor unit and ME remote controller.

The address No. is set at the address setting board.

In the case of WR2 system, it is necessary to set the same No. at the branch No. switch of indoor unit as that of the BC controller connected. (When connecting two or more branches, use the lowest branch No.)

② Caution for switch operations

- Be sure to shut off power source before switch setting. If operated with power source on, switch can not operate properly.
- No units with identical unit address shall exist in one whole air conditioner system. If set erroneously, the system can not operate.

③ MA remote controller

- When connecting only one remote controller to one group, it is always the main remote controller. When connecting two remote controllers to one group, set one remote controller as the main remote controller and the other as the sub remote controller.
- The factory setting is "Main".

PAC-YT53CRAU







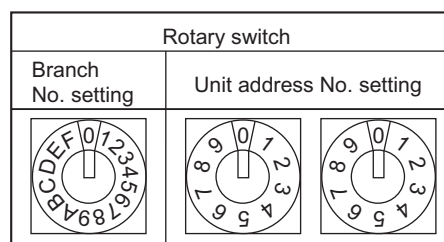





























Setting the dip switches

There are switches on the back of the top case. Remote controller Main/Sub and other function settings are performed using these switches. Ordinarily, only change the Main/Sub setting of SW1. (The factory settings are ON for SW1, 3, and 4 and OFF for SW2.)

SW No	SW contents	Main	ON	OFF	Comment
1	Remote controller Main/Sub setting	Main	Main	Sub	Set one of the two remote controllers at one group to "ON".
2	Temperature display units setting	Celsius	Celsius	Fahrenheit	When the temperature is displayed in [Fahrenheit], set to "OFF".
3	Cooling/heating display in AUTO mode	Yes	Yes	No	When you do not want to display "Cooling" and "Heating" in the AUTO mode, set to "OFF".
4	Indoor temperature display	Yes	Yes	No	When you do not want to display the indoor temperature, set to "OFF".



2-4-2. Rule of setting address

Unit	Address setting	Example	Note
Indoor unit System control interface (MAC-333IF-E) A-M converter (PAC-IF01MNT-E)	01 ~ 50	 	Use the most recent address within the same group of indoor units. Make the indoor units address connected to the BC controller (Sub) larger than the indoor units address connected to the BC controller (Main). If applicable, set the sub BC controllers in an PQR system in the following order: (1) Indoor unit to be connected to the BC controller (Main) (2) Indoor unit to be connected to the BC controller (No.1 Sub) (3) Indoor unit to be connected to the BC controller (No.2 Sub) Set the address so that (1)<(2)<(3)
Heat source unit	51 ~ 99, 100 (Note1)	 	The smallest address of indoor unit in same refrigerant system + 50 Assign sequential address numbers to the heat source units in one refrigerant circuit system. OC and OS are automatically detected. (Note 2) * Please reset one of them to an address between 51 and 99 when two addresses overlap. * The address automatically becomes "100" if it is set as "01~ 50"
BC controller (Main)	52 ~ 99, 100	 	The address of heat source unit + 1 * Please reset one of them to an address between 51 and 99 when two addresses overlap. * The address automatically becomes "100" if it is set as "01~ 50"
BC controller (Sub)	52 ~ 99, 100	 	Lowest address within the indoor units connected to the BC controller (Sub) plus 50.
Local remote controller	ME, LOSSNAY Remote controller (Main)	1 Fixed  	The smallest address of indoor unit in the group + 100 * The place of "100" is fixed to "1"
	ME, LOSSNAY Remote controller (Sub)	1 Fixed  	The address of main remote controller + 50 * The address automatically becomes "200" if it is set as "00"
System controller	ON/OFF remote controller	  	The smallest group No. to be managed + 200 * The smallest group No. to be managed is changeable.
	AE-200A/AE-50A AG-150A-A EB-50GU-A EW-50A TC-24B	0  0  0 	* TC-24B cannot be set to "000".
	PAC-YG50ECA	0  0  0 	* Settings are made on the initial screen of AG-150A-A.
	BAC-HD150	0  0  0 	* Settings are made with setting tool of BM ADAPTER.
	LMAP04U-E	2 Fixed  	
PI, AI, DIDO	PAC-YG60MCA	 	
	PAC-YG63MCA	 	
	PAC-YG66DCA	 	
LOSSNAY	01 ~ 50	 	After setting the addresses of all the indoor units, assign an arbitrary address.
PAC-IF01AHC-J	201 ~ 250	2 Fixed  	

Note1: To set the address to "100", set it to "50"

Note2: Heat source units OC and OS in one refrigerant circuit system are automatically detected.
OC and OS are ranked in descending order of capacity. If units are the same capacity, they are ranked in ascending order of their address.

S.D. WY 575V

2-4-3. System examples

Factory setting

Original switch setting of the heat sources, indoors, controllers, LM-AP, and BM ADAPTER at shipment is as follows.

- Heat source unit : Address: 00, CN41: ON (Jumper), DipSW5-1: OFF
- Indoor unit : Address: 00
- ME remote controller : Address: 101
- LM-AP : Address: 247, CN41: ON (Jumper), DipSW1-2: OFF
- BM ADAPTER : Address: 000, CN41: ON (Jumper)

Setting at the site

- DipSW5-1(Heat source) : When the System Controller is used, all the Dip SW5-1 at the heat source units should be set to "ON". * Dip SW5-1 remains OFF when only LM-AP is used.
- DipSW1-2(LM-AP) : When the LM-AP is used together with System Controller, DipSW1-2 at the LM-AP should be set to "ON".
- CN40/CN41 : Change jumper from CN41 to CN 40 at heat source control board will activate central transmission power supply to TB7;
(Change jumper at only one heat source unit when activating the transmission power supply without using a power supply unit.)
Change jumper from CN41 to CN 40 at LM-AP will activate transmission power supply to LM-AP itself;
Power supply unit is recommended to use for a system having more than 1 heat source unit, because the central transmission power supply from TB7 of one of heat source units is risking that the heat source unit failure may let down the whole system controller system.

2-4-3-1. MA remote controller, Single-refrigerant-system, No System Controller

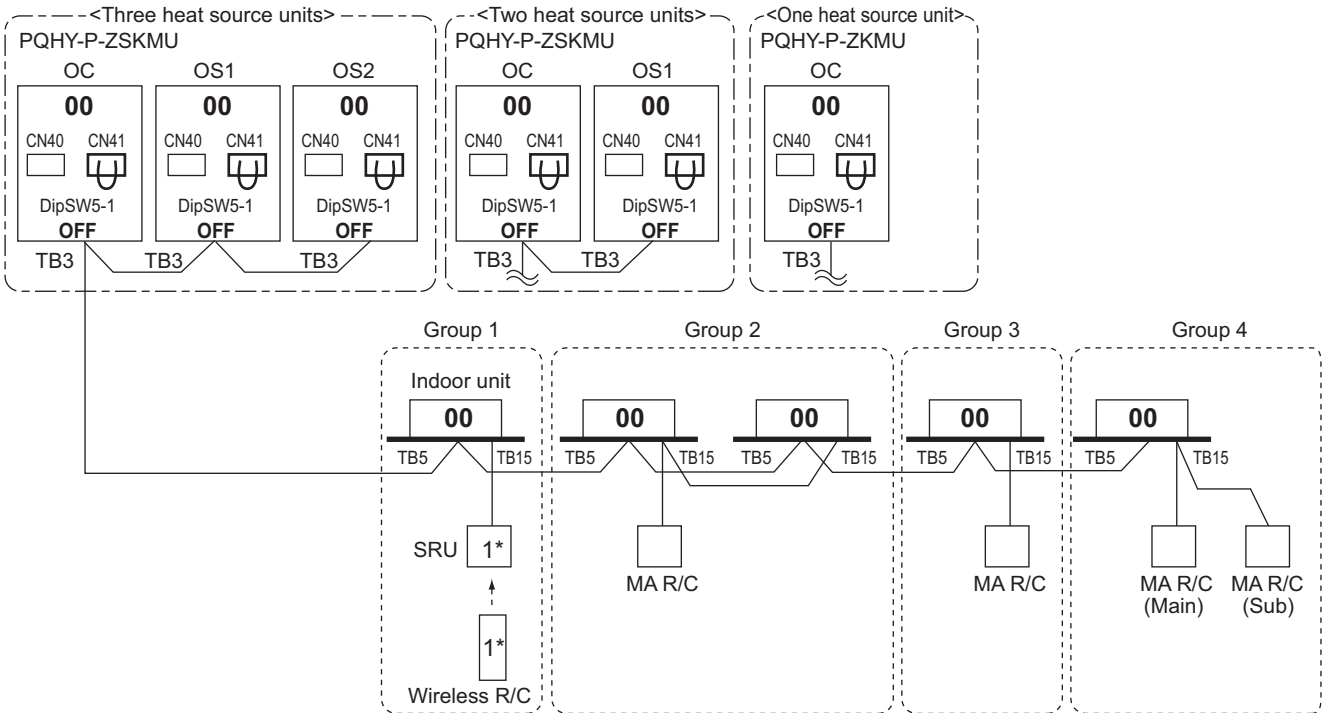

*1 For Wireless R/C and Signal receiver unit (SRU), channel 1, 2 and 3 are selectable and should be set to same channel.

NOTE:

1. Heat source units OC, OS1 and OS2 in one refrigerant circuit system are automatically detected. OC, OS1 and OS2 are ranked in descending order of capacity. If units are the same capacity, they are ranked in ascending order of their address.
2. No address setting is needed.
3. For a system having more than 32 indoor unit (P06-P54), confirm the need of Booster at 2-3 "System configuration restrictions".

S.D. WY 575V

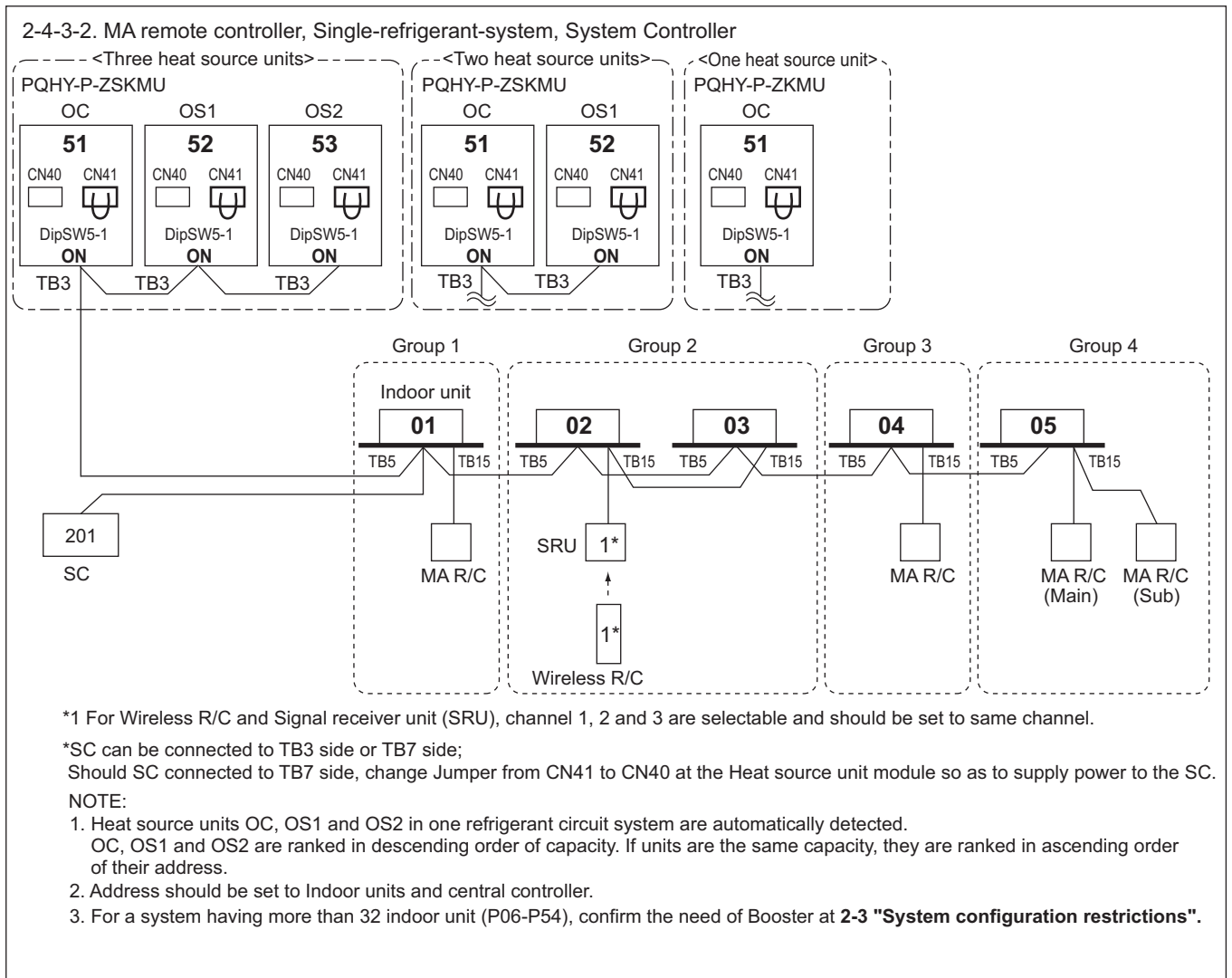

2-4-3-3. MA remote controller, Multi-refrigerant-system, System Controller at TB7/TB3 side, Booster for long M-NET wiring

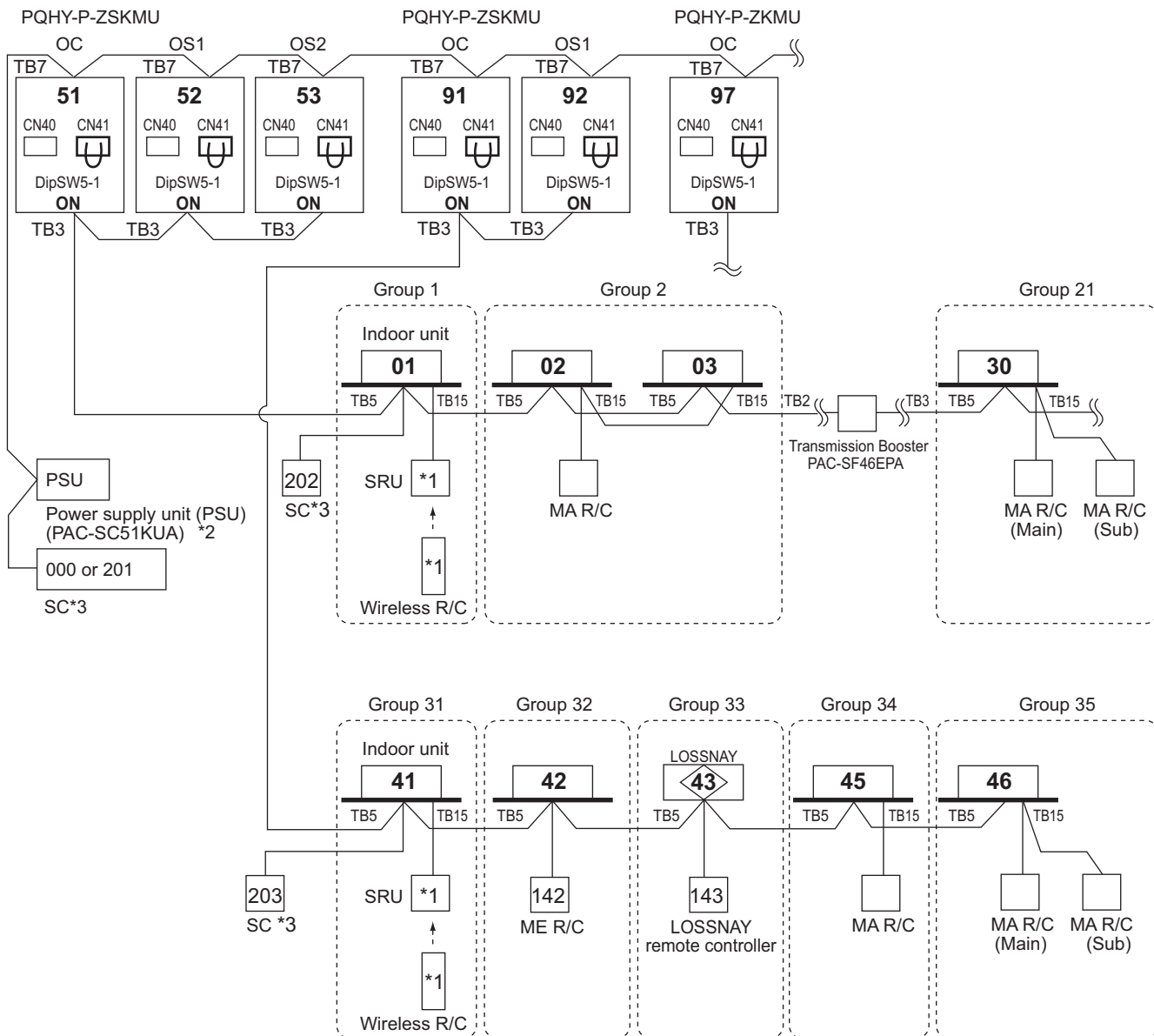

*1 For Wireless R/C and Signal receiver unit (SRU), channel 1, 2 and 3 are selectable and should be set to same channel.

*2 System controller should connect to TB7 at the Heat source unit and use power supply unit together in Multi-Refrigerant-System. For AG-150A-A, 24V DC should be used with the PAC-SC51KUA.

*3 When multiple system controllers are connected in the system, set the controller with more functions than others as a "main" controller and others as "sub".
 TC-24A, AG-150A-A, GB-50ADA-A and GB-24A are for exclusive use as a "main" system controller and cannot be used as a "sub" system controller.
 Make the setting to only one of the system controllers for "prohibition of operation from local remote controller".

NOTE:

- Heat source units OC, OS1 and OS2 in one refrigerant circuit system are automatically detected. OC, OS1 and OS2 are ranked in descending order of capacity. If units are the same capacity, they are ranked in ascending order of their address.
- Address should be set to Indoor units, LOSSNAY and system controller.
- M-NET power is supplied by the Heat source unit at TB3, while Indoor unit and ME remote controller consume the M-NET power for transmission use. The power balance is needed to consider for long M-NET wiring. Details refer to 2-3 "System configuration restrictions".

S.D. WY 575V

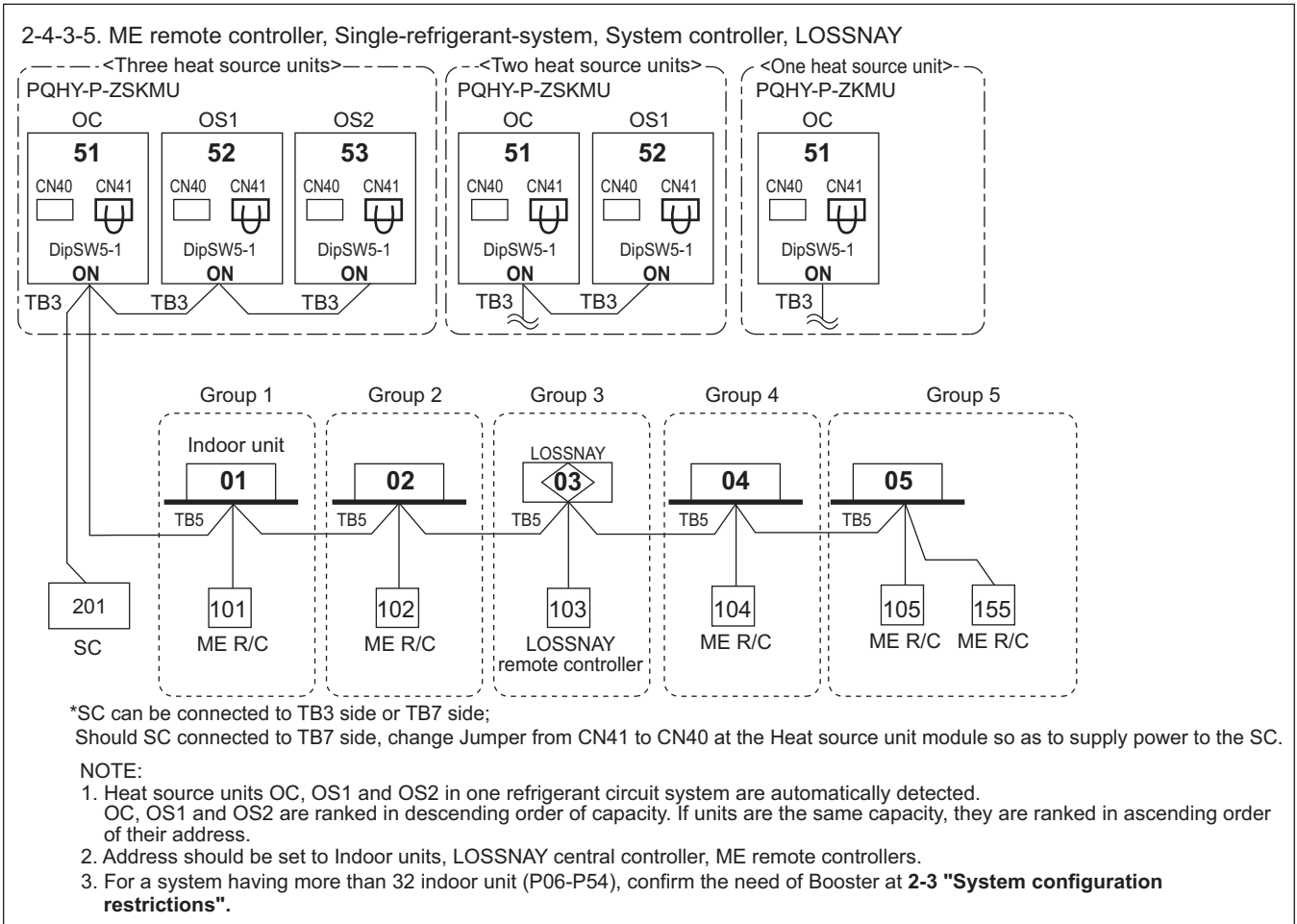
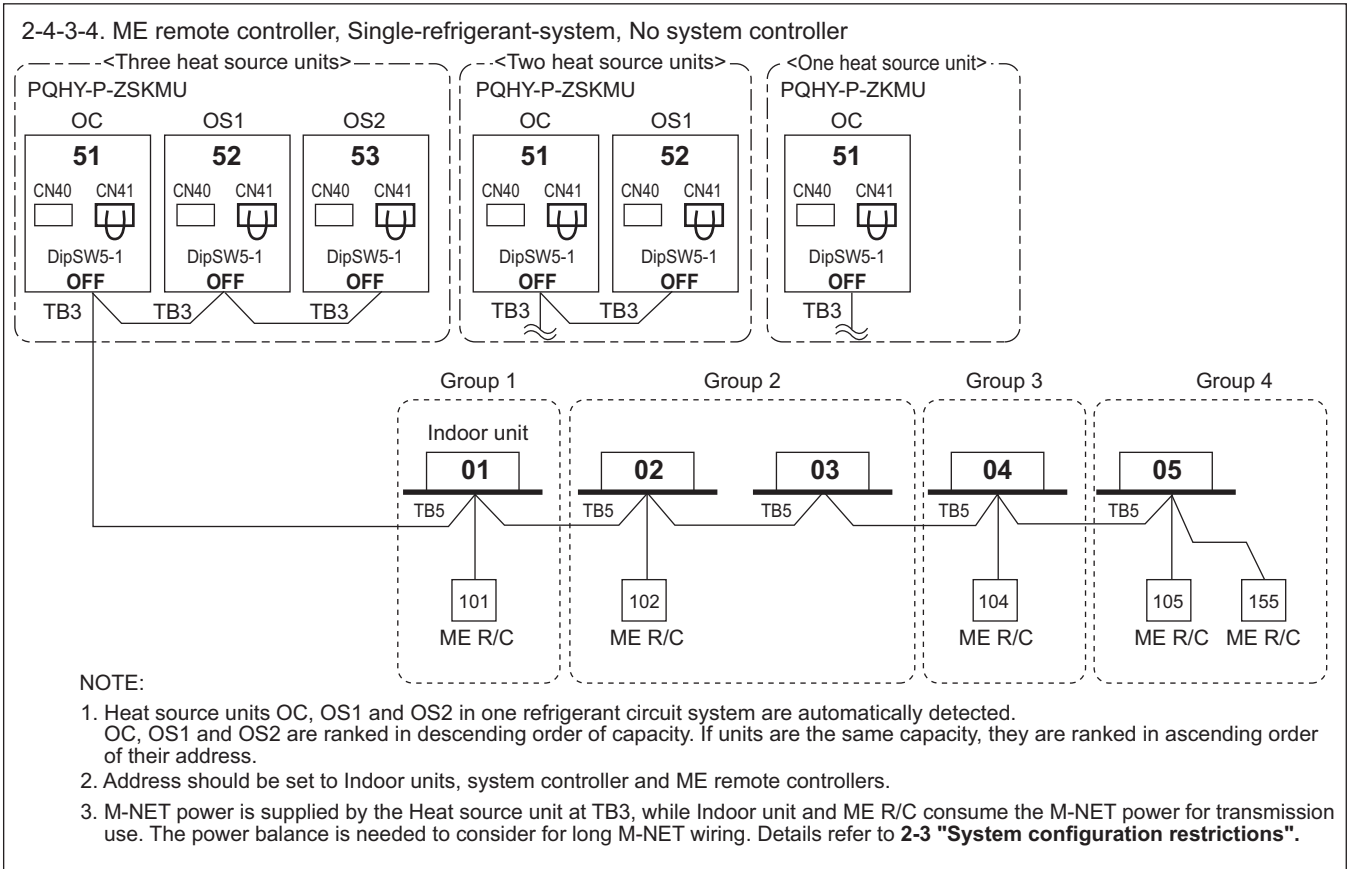

S.D. WY 575V

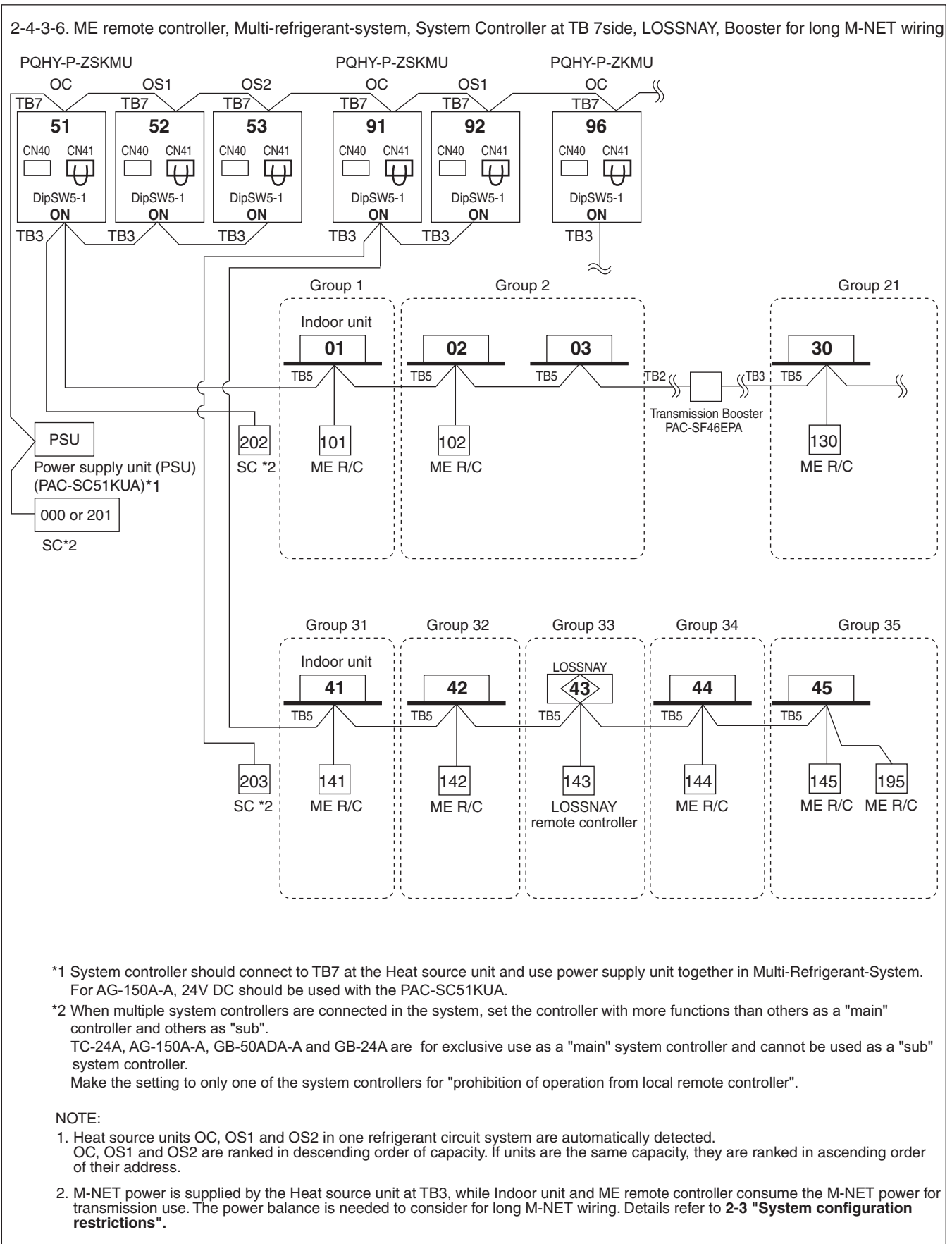

S.D. WY 575V

2-4-3-7. TG-2000A(*1)+AG-150A-A*2,GB-50ADA-A

AG-150A-A can control max. 50 indoor units;
 GB-50ADA-A can control max. 50 indoor units;
 TG-2000A can control max. 40 of AG-150A-A and GB-50ADA-A;*3
 TG-2000A can control max. 2000 indoor units.

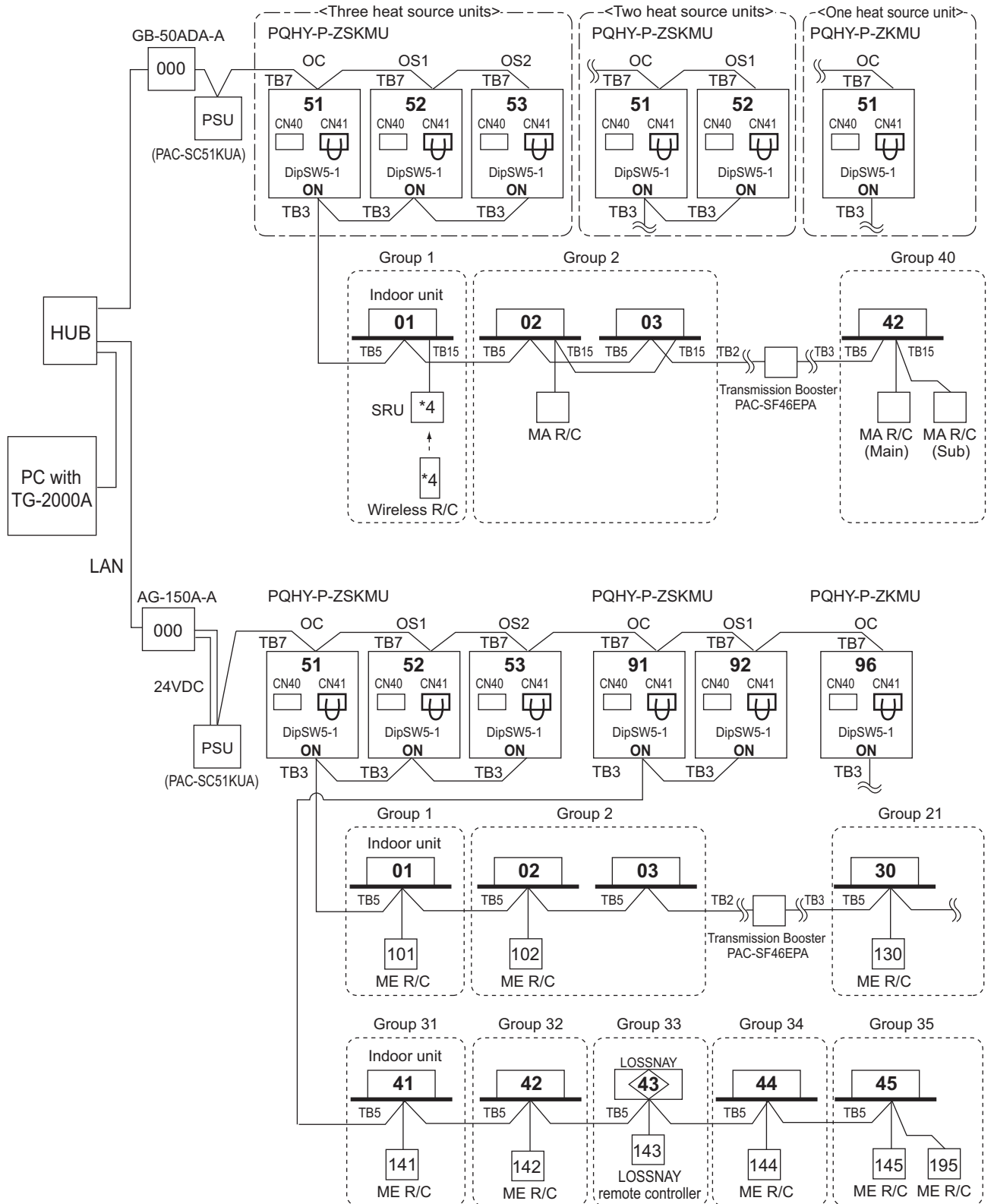

- NOTE**
- *1 TG-2000A (Ver.5.5 or later) supports AG-150A-A (Ver.1 series).
 TG-2000A (Ver. 6.1 or later) supports AG-150A-A (Ver. 2.1 or later) connected with the expansion controller (EC).
 TG-2000A (Ver. 6.3 or later) supports GB-50ADA-A.
 - *2 AG-150A-A (Ver.1 series) does not support the expansion controller (EC).
 - *3 When AG-150A-A connected with the expansion controller (EC) is connected, the number of EC will be the maximum controllable number.
 TG-2000A can control up to 40 EC or AG-150A-A without EC connection.
 - *4 For Wireless R/C and Signal receiver unit (SRU), channel 1, 2 and 3 are selectable and should be set to same channel.

S.D. WY 575V

2-4-3-8. AG-150A-A + PAC-YG50ECA (Expansion controller)

AG-150A-A can control max. 150 indoor units via expansion controllers.

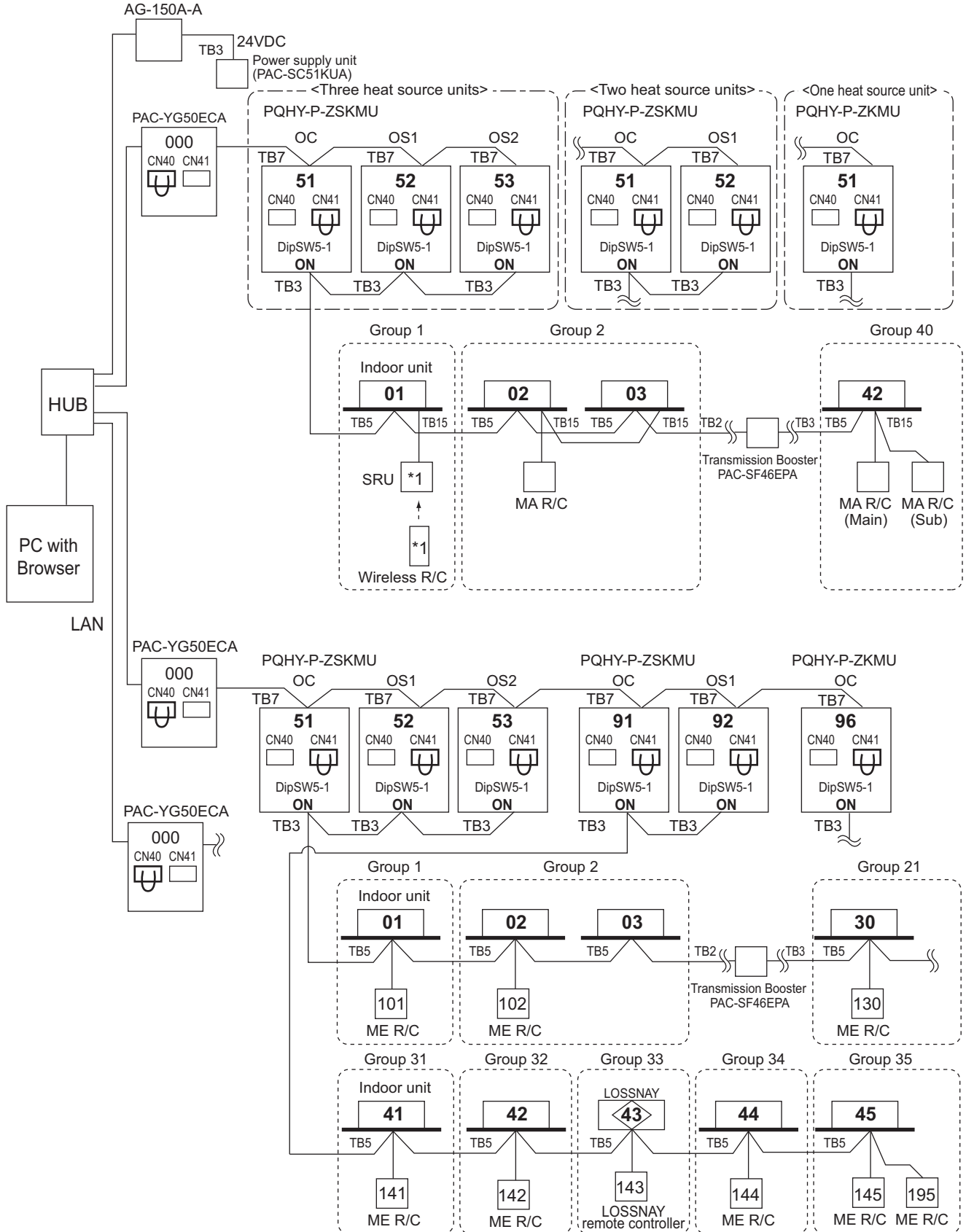

NOTE

- When connecting AG-150A-A to PAC-YG50ECA, TB2 for power supply unit does not need to be connected to AG-150A-A.
- *1 For Wireless R/C and Signal receiver unit (SRU), channel 1, 2 and 3 are selectable and should be set to same channel.

S.D. WY 575V

2-4-3-9. LM-AP

LM-AP can transmit for max. 50 indoor units;

If system controller (SC) is used, DipSW1-2 at LM-AP and DipSW5-1 at Heat source unit should set to "ON".

Change Jumper from CN41 to CN40 to activate power supply to LM-AP itself for those LM-AP connected without system controller (SC).

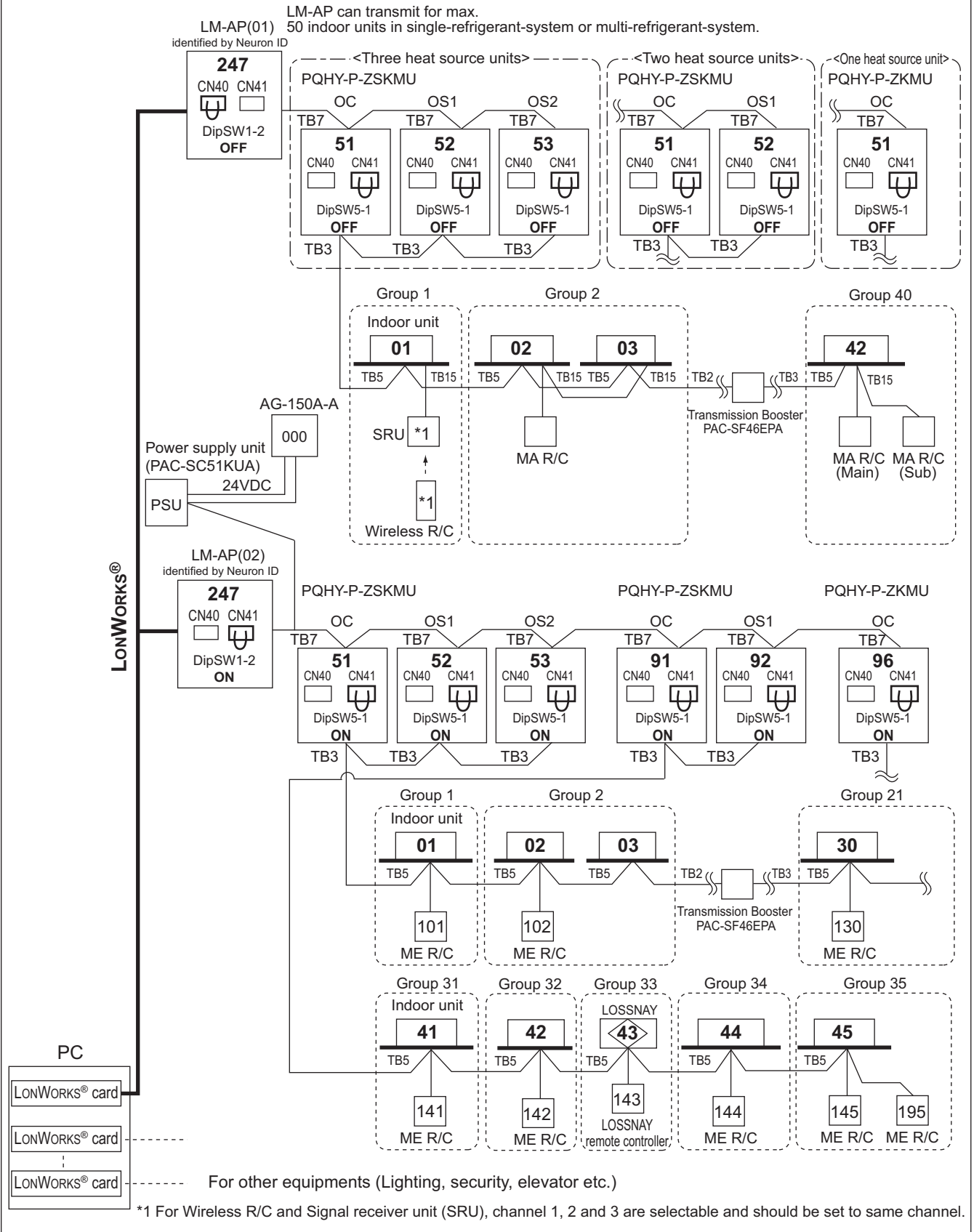

S.D. WY 575V

2-4-3-10. BM ADAPTER

BM ADAPTER can transmit for max. 50 indoor units;
 Change Jumper from CN41 to CN40 to activate power supply to BM ADAPTER itself for those BM ADAPTER connected without the power supply unit.

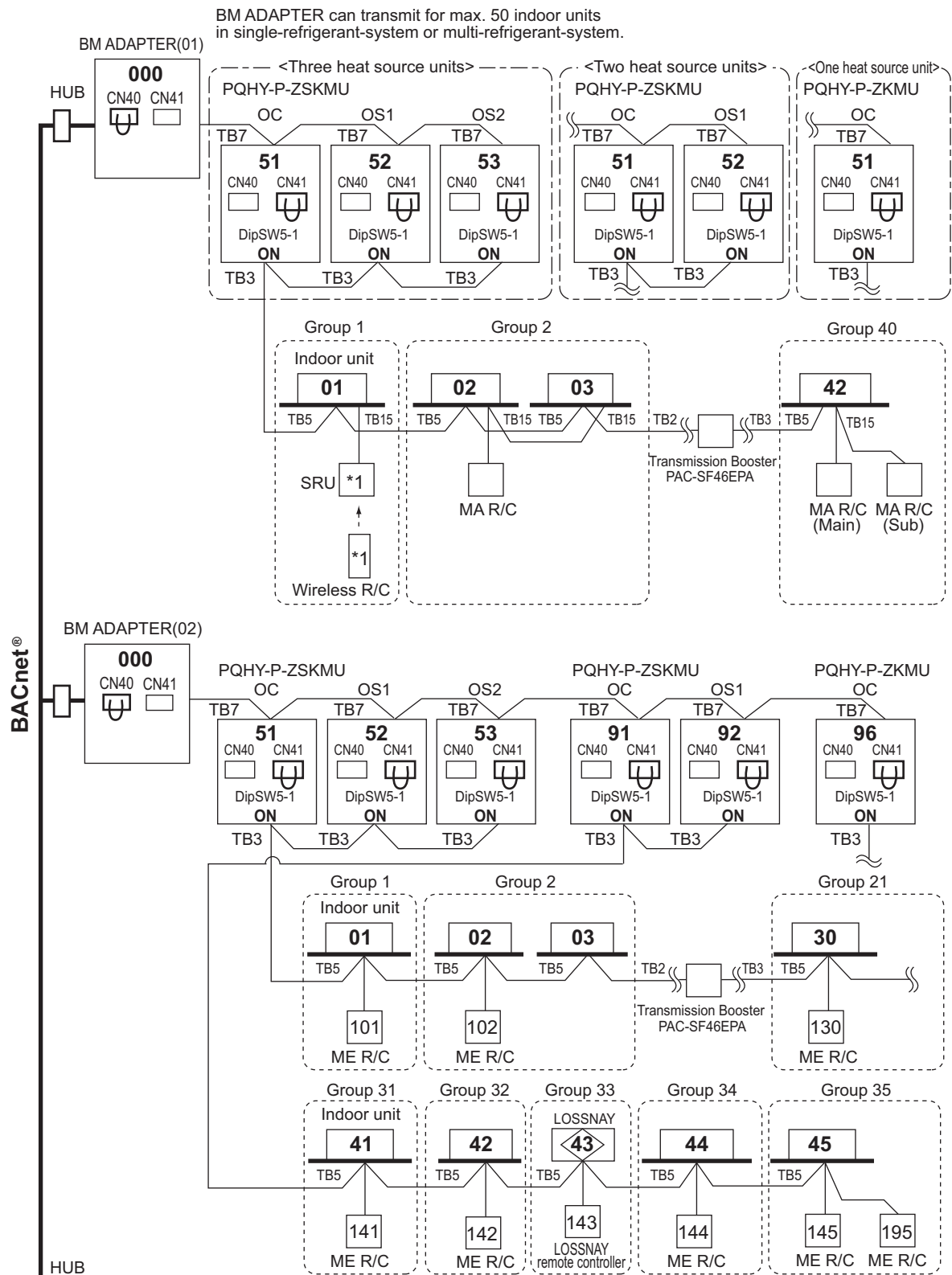

*1 For Wireless R/C and Signal receiver unit (SRU), channel 1, 2 and 3 are selectable and should be set to same channel.

S.D. WY 575V

2-4-3-11. BM ADAPTER + PAC-YG50ECA (Expansion controller)

BM ADAPTER*1 can transmit for max. 150 indoor units via expansion controllers (PAC-YG50ECA). When the dual-set-point function is used, no expansion controllers can be connected, and only up to 50 units can be controlled from each BAC-HD150.

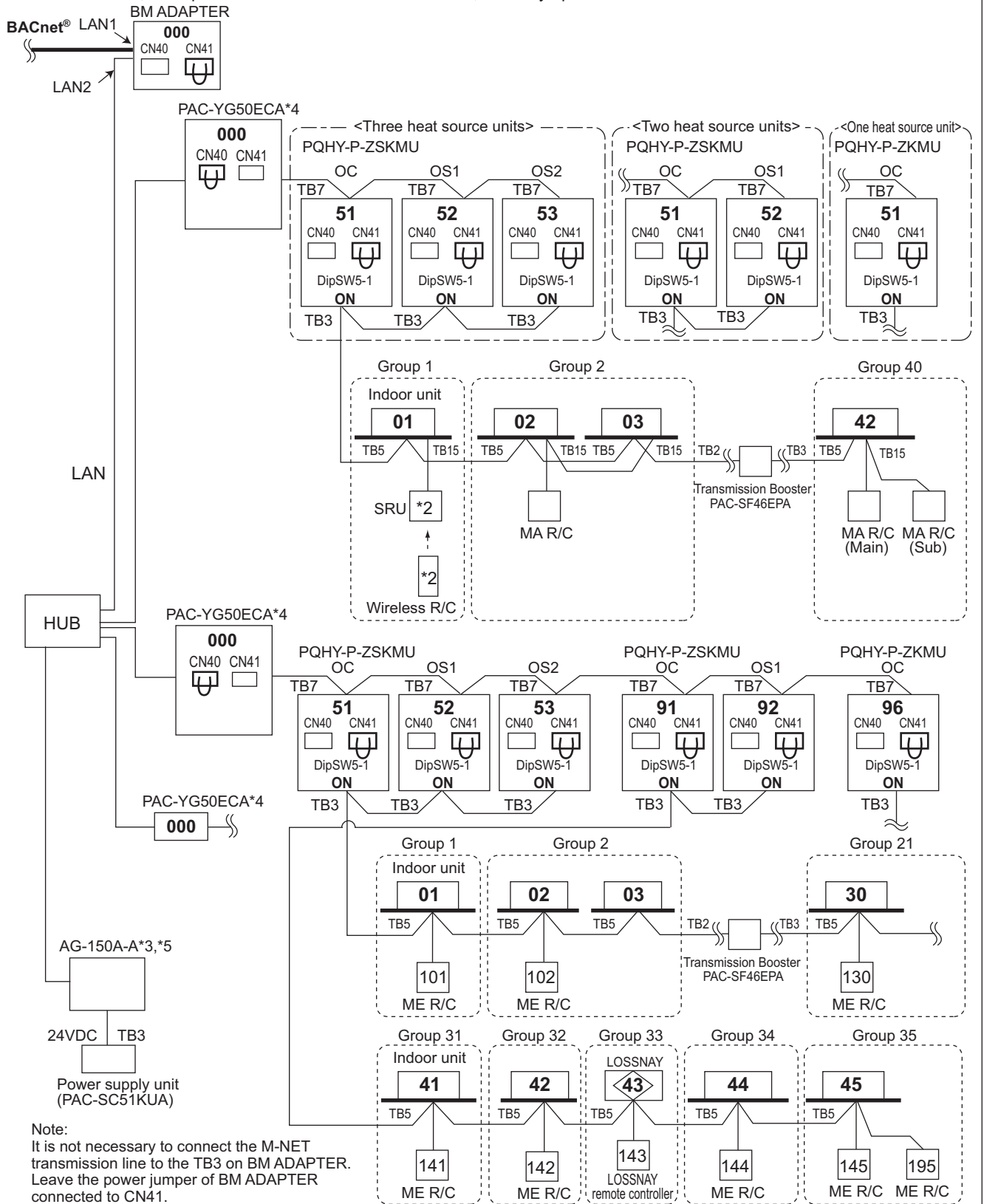

Note:
It is not necessary to connect the M-NET transmission line to the TB3 on BM ADAPTER. Leave the power jumper of BM ADAPTER connected to CN41.

- *1 BM ADAPTER (Ver. 2.00 or later) supports the PAC-YG50ECA.
- *2 For Wireless R/C and Signal receiver unit (SRU), channel 1, 2 and 3 are selectable and should be set to same channel.
- *3 AG-150A-A (Ver. 2.30 or later) supports the PAC-YG50ECA.
- *4 PAC-YG50ECA (Ver. 1.30 or later) supports the BM ADAPTER.
- *5 Consult your dealer for restrictions when connecting both AG-150A-A and BM ADAPTER to PAC-YG50ECA.

S.D. WY 575V

3-1. R410A Piping material

The maximum operation pressure of R410A air conditioner is 4.15 MPa [601 psi]. The refrigerant piping should ensure the safety under the maximum operation pressure. You shall follow the local industrial standard.

Procedures for installing the branched pipes

Refer to the instructions that came with the branched pipe kit (separately sold) for details.

[1] Branches on the indoor-unit side

■Joint

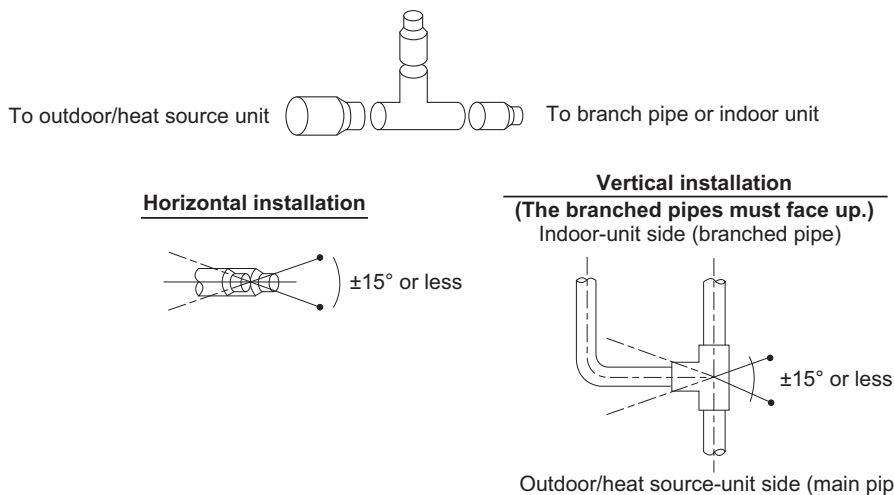

- Restrictions for installing the joint described here only apply to CMY-Y202S-G2 and CMY-Y302S-G2 in the gas line.
- CMY-Y202S-G2 and CMY-Y302S-G2 in the gas line must be installed horizontally (see figure above) or with the branched pipes facing up.
- If the size of the refrigerant pipe that is selected by following the instructions under 3-2. Piping Design does not match the size of the joint, use a reducer to connect them. A reducer is included in the kit.

■Header

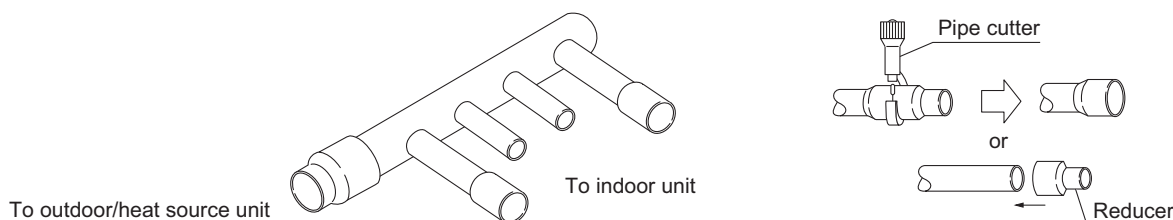

- No restrictions apply to the installation of the header.
- If the size of the refrigerant pipe that is selected by following the instructions under 3-2. Piping Design does not match the size of the header, cut the pipe to an appropriate size using a pipe cutter, or use a reducer to connect them.
- If the number of header branches exceeds the number of pipes to be connected, cap the unused header branches. Caps are included in the kit.

[2] Branches on the outdoor/heat source-unit side

Note. Refer to the figure below for the installation position of the twinning pipe.

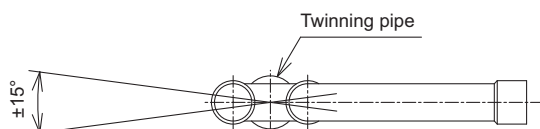

Slope of the twinning pipes are at an angle within $\pm 15^\circ$ to the horizontal plane.

- Inclination of the branched pipes
The inclination of the branched pipes must be $\pm 15^\circ$ or less against the horizontal plane. Excessive inclination of the branched pipes may damage the unit.
- Minimum length of the straight section of the pipe before the branched pipes
Always use the pipes supplied in the branched pipe kit, and make sure the straight section of the pipe immediately before it connects to the branched pipe is at least 500 mm. Failure to do so may damage the unit.

3-2. Piping Design

Selecting refrigerant pipes

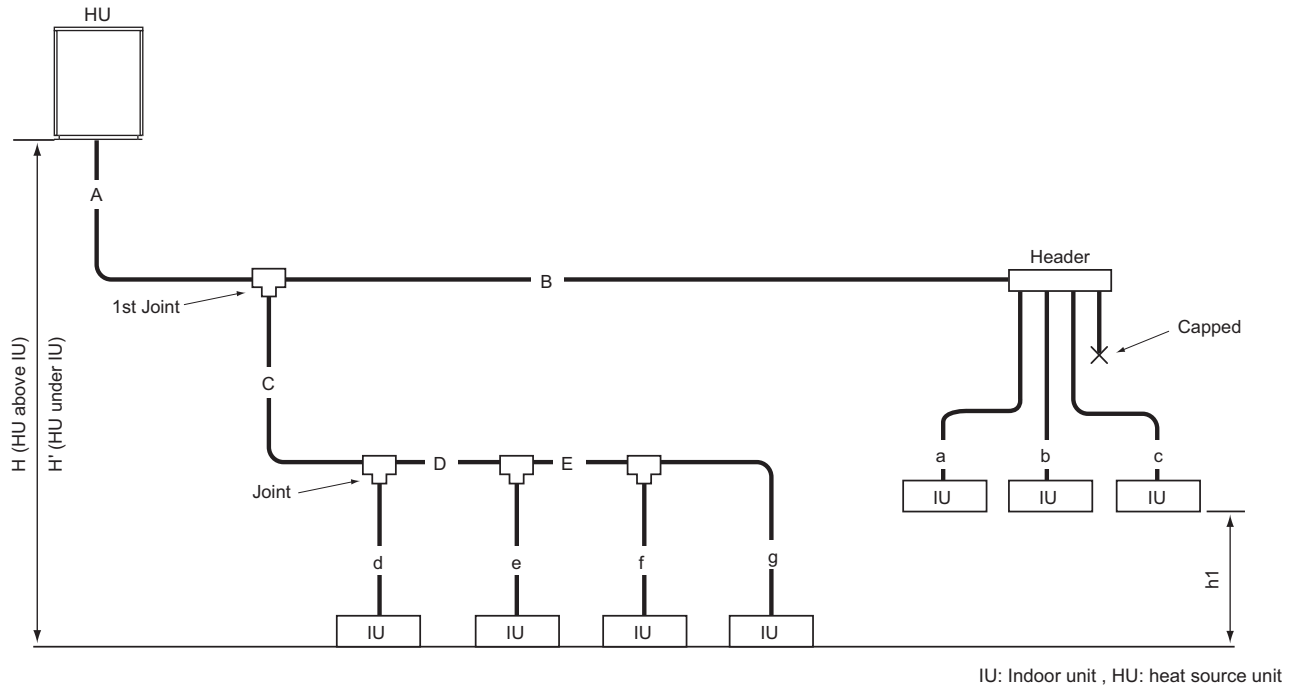

1. Selecting joints

Select joints from Table 4-1 [Selection criteria for joints] based on the total capacity of indoor units on the downstream side.

When selecting the first joint for the system to which the heat source unit listed in Table 4-2 [See the table below for the first joint of the heat source unit described below.] is connected, select the first joint from Table 4-2.

2. Selecting headers

Select headers from Table 5 [Header selection rule] based on the number of indoor units to be connected.

Refer to Table 5, which shows the total capacity limits, for the indoor units to be connected on the downstream side.

When connecting a header directly to the heat source unit, select the header by referring to the notes in Table 5.

*The piping cannot be branched on the downstream of the header.

3. Selecting refrigerant pipe sizes

(1) Between heat source unit and the 1st joint [A]

Select the appropriate size pipes for the selected heat source unit from Table 1 [Piping "A" size selection rule].

(2) Between joints [B, C, D, and E]

Select the appropriate size pipes from Table 2 [Piping "B", "C", "D", ... size selection rule] based on the total capacity of indoor units on the downstream side.

(3) Between joints and indoor units [a, b, c, d, e, f, and g]

Select the appropriate size pipes from Table 3 [Piping "a", "b", "c", "d", ... size selection rule] based on the capacity of indoor units.

(4) After selecting the pipe sizes in accordance with steps (1) through (3) above, if the size of the pipes on the downstream is larger than that on the upstream, it is not necessary to be bigger than the upstream one.

4. Checking the refrigerant charge

Calculate the amount of refrigerant to be added based on the pipe sizes selected in Items 1 through 3 above, and make sure that the total amount of the initial charge and the additional charge combined will not exceed the maximum allowable refrigerant charge amount.

If this amount exceeds the maximum allowable amount, redesign the system (i.e., piping length) so that the total refrigerant charge will not exceed the maximum allowable amount.

3-2-1. PQHY-P72-120ZKMU Piping

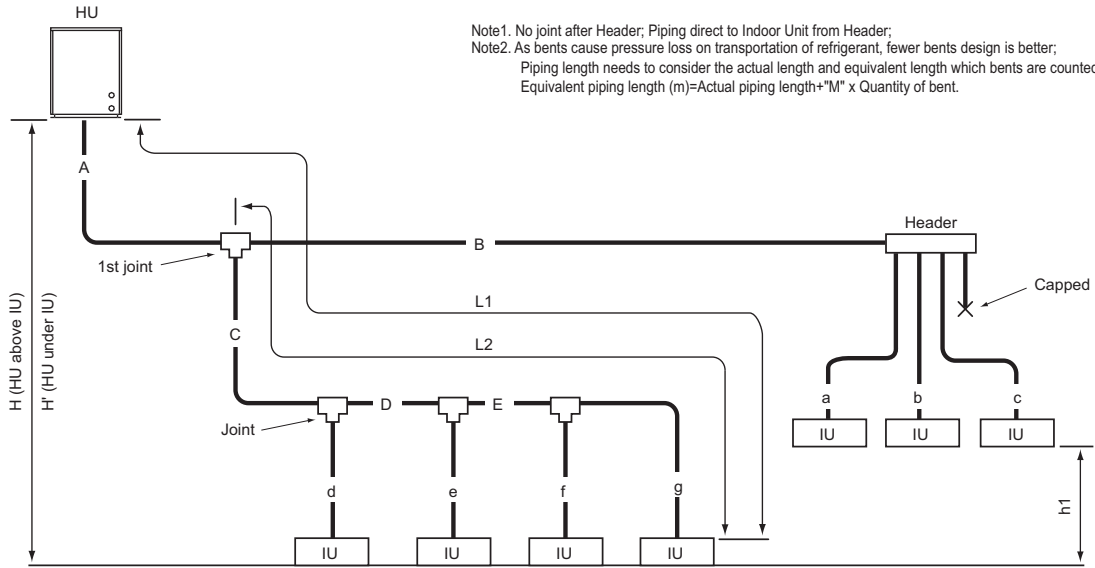

Note1. No joint after Header; Piping direct to Indoor Unit from Header;
 Note2. As bents cause pressure loss on transportation of refrigerant, fewer bents design is better;
 Piping length needs to consider the actual length and equivalent length which bents are counted.
 Equivalent piping length (m)=Actual piping length+“M” x Quantity of bent.

Fig. 3-2-1A Piping scheme

IU: Indoor unit, HU: Heat source unit

Piping length		(m [ft.])		Bends equivalent length "M"	
Item	Piping in the figure	Max. length	Max. equivalent length	Heat source Model	M (m/bends [ft./bends])
Total piping length	A+B+C+D+E+a+b+c+d+e+f+g	300 [984]	-	PQHY-P72ZKMU	0.35 [1.15]
Farthest IU from HU (L1)	A+C+D+E+g / A+B+c	165 [541]	190 [623]	PQHY-P96ZKMU	0.42 [1.38]
Farthest IU from first joint (L2)	C+D+E+g / B+c	40 [131]	40 [131]	PQHY-P120ZKMU	0.42 [1.38]
Height between HU and IU (HU above IU)	H	50 [164]	-		
Height between HU and IU (HU under IU)	H'	40 [131]	-		
Height between IU and IU	h1	15 [49]	-		

HU: Heat source Unit, IU: Indoor Unit

Table1. Piping "A" size selection rule (mm [in.])

Heat source unit	Pipe(Liquid)	Pipe(Gas)
PQHY-P72ZKMU	ø9.52 [3/8]	ø19.05 [3/4]
PQHY-P96ZKMU	ø9.52 [3/8] *1	ø22.20 [7/8]
PQHY-P120ZKMU	ø9.52 [3/8] *2	ø22.20 [7/8]

*1. L1>=90 m [295 ft.], ø12.70 mm [1/2 in.];
 *2. L1>=40 m [131 ft.], ø12.70 mm [1/2 in.]

Table4-1. Selection criteria for joints

Total down-stream Indoor capacity	Joint
~ P72	CMY-Y102SS-G2
P73 ~ P144	CMY-Y102LS-G2
P145 ~ P240	CMY-Y202S-G2
P241 ~	CMY-Y302S-G2

*Concerning detailed usage of joint parts, refer to its Installation Manual.

Table4-2.
 See the table below for the first joint of the heat source unit described below.

heat source unit model	Joint model
P96 to P120	CMY-Y102SS/LS-G2

Table2. Piping "B","C","D","E" size selection rule (mm [in.])

Total down-stream Indoor capacity	Pipe(Liquid)	Pipe(Gas)
~ P54	ø9.52 [3/8]	ø15.88 [5/8]
P55 ~ P72	ø9.52 [3/8]	ø19.05 [3/4]
P73 ~ P108	ø9.52 [3/8]	ø22.20 [7/8]
P109 ~ P144	ø12.70 [1/2]	ø28.58 [1-1/8]
P145 ~ P240	ø15.88 [5/8]	ø28.58 [1-1/8]
P241 ~ P308	ø19.05 [3/4]	ø34.93 [1-3/8]
P309 ~	ø19.05 [3/4]	ø41.28 [1-5/8]

Table5. Header selection rule

Total down-stream Indoor capacity	4-branch Header	8-branch Header	10-branch Header
	CMY-Y104C-G	CMY-Y108C-G	CMY-Y1010C-G
	<=P72	<=P144	<=P240

* CMY-Y104C-G can directly connect PQHY-P72ZKMU, but can NOT directly connect PQHY-P96ZKMU or above;
 * CMY-Y108C-G can directly connect PQHY-P72-168Z(S)JKMU, but can NOT directly connect PQHY-P192ZSKMU or above;
 * CMY-Y1010C-G can directly connect PQHY-P72-240Z(S)JKMU;
 * CMY-Y104C-G can NOT connect P72~P96 Indoor, but CMY-Y108,Y1010C-G can do;
 * Concerning detailed usage of Header parts, refer to its Installation Manual.

Table3. Piping "a","b","c","d","e","f","g" size selection rule (mm [in.])

Indoor Unit size	Pipe(Liquid)	Pipe(Gas)
P06,P08,P12,P15,P18	ø6.35 [1/4]	ø12.70 [1/2]
P24,P27,P30,P36,P48,P54	ø9.52 [3/8]	ø15.88 [5/8]
P72	ø9.52 [3/8]	ø19.05 [3/4]
P96	ø9.52 [3/8]	ø22.20 [7/8]

Note3. Indoor capacity is described as its model size;
 For example, PEFY-P06NMAU-E3, its capacity is P06;
 Note4. Total down-stream Indoor capacity is the summary of the model size of Indoors downstream.
 For example, PEFY-P06NMAU-E3+PEFY-P08NMAU-E3: Total Indoor capacity=P06+P08=P14
 Note5. Piping sized determined by the Total down-stream indoor capacity is NOT necessary to be bigger than the up-stream one.
 i.e. A>=B; A>=C>=D

S.D. WY 575V

3-2-2. PQHY-P144-240ZSKMU Piping

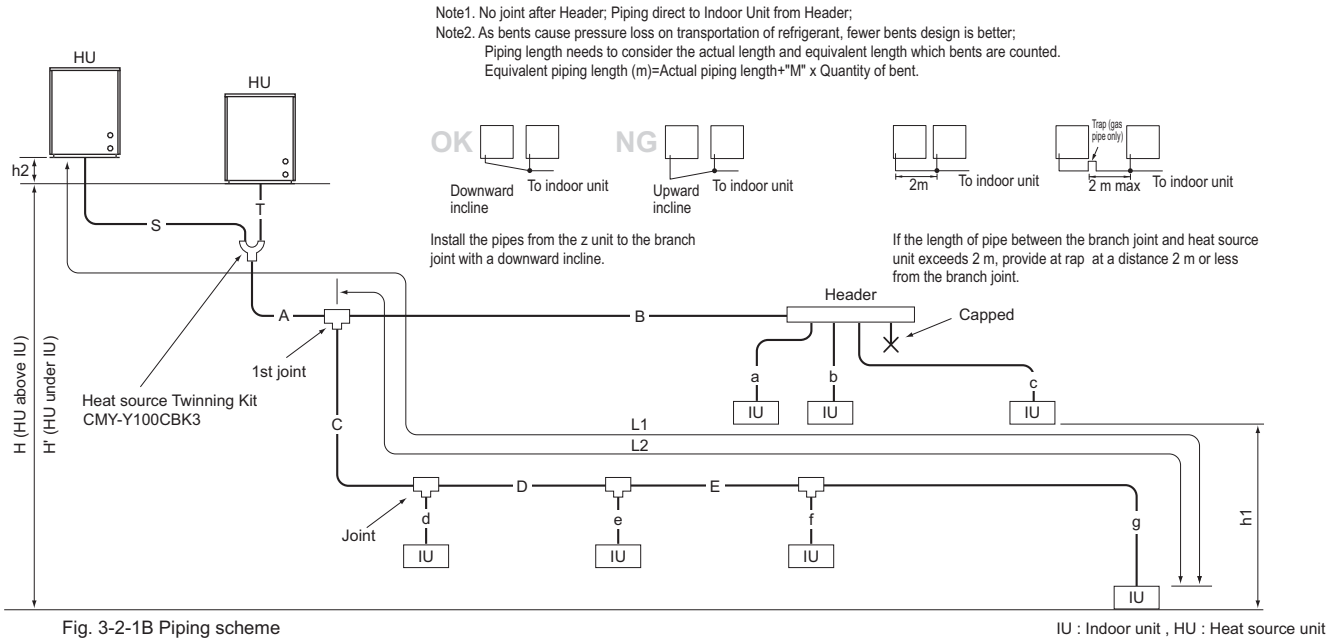

Piping length Item	Piping in the figure	Piping length (m [ft.])		Bends equivalent length "M"	
		Max. length	Max. equivalent length	Heat source Model	M (m/bends [ft./bends])
Total piping length	S+T+A+B+C+D+E+a+b+c+d+e+f+g	500 [1640]	-	PQHY-P144ZSKMU	0.50 [1.64]
Distance between HU and HU	S+T	10[32]	-	PQHY-P168ZSKMU	0.50 [1.64]
Height between HU and HU	h2	0.1[0.3]	-	PQHY-P192ZSKMU	0.50 [1.64]
Farthest IU from HU (L1)	S(T)+A+C+D+E+g / S(T)+A+B+c	165 [541]	190 [623]	PQHY-P216ZSKMU	0.50 [1.64]
Farthest IU from the first joint (L2)	C+D+E+g / B+c	40 [131]	40 [131]	PQHY-P240ZSKMU	0.50 [1.64]
Height between HU and IU (HU above IU)	H	50 [164]	-		
Height between HU and IU (HU under IU)	H'	40 [131]	-		
Height between IU and IU	h1	15 [49]	-		

HU: Heat source Unit, IU: Indoor Unit

Table1. Piping "A" size selection rule

Heat source unit	Pipe size (mm [in.])	
	Pipe(Liquid)	Pipe(Gas)
PQHY-P144ZSKMU	ø12.70[1/2]	ø28.58[1-1/8]
PQHY-P168-240ZSKMU	ø15.88[5/8]	ø28.58[1-1/8]

For Piping size "S","T", please refer to specification of the Twinning kit CMY-Y100CBK3 at the Heat source unit's external drawing.

Table2. Piping "B","C","D","E" size selection rule

Total down-stream Indoor capacity	Pipe size (mm [in.])	
	Pipe(Liquid)	Pipe(Gas)
~ P54	ø9.52 [3/8]	ø15.88 [5/8]
P55 ~ P72	ø9.52 [3/8]	ø19.05 [3/4]
P73 ~ P108	ø9.52 [3/8]	ø22.20 [7/8]
P109 ~ P144	ø12.70 [1/2]	ø28.58 [1-1/8]
P145 ~ P240	ø15.88 [5/8]	ø28.58 [1-1/8]
P241 ~ P308	ø19.05 [3/4]	ø34.93 [1-3/8]
P309 ~	ø19.05 [3/4]	ø41.28 [1-5/8]

Table3. Piping "a","b","c","d","e","f","g" size selection rule

Indoor Unit size	Pipe size (mm [in.])	
	Pipe(Liquid)	Pipe(Gas)
P06,P08,P12,P15,P18	ø6.35 [1/4]	ø12.70 [1/2]
P24,P27,P30,P36,P48,P54	ø9.52 [3/8]	ø15.88 [5/8]
P72	ø9.52 [3/8]	ø19.05 [3/4]
P96	ø9.52 [3/8]	ø22.20 [7/8]

Table4-1. Selection criteria for joints

Total down-stream Indoor capacity	Joint
~ P72	CMY-Y102SS-G2
P73 ~ P144	CMY-Y102LS-G2
P145 ~ P240	CMY-Y202S-G2
P241 ~	CMY-Y302S-G2

*Concerning detailed usage of joint parts, refer to its Installation Manual.
 *The total capacity of the units in the downstream of the branch joint on at least one of the piping lines that are connected to the branch joint should be 240 or below.
 If the total capacity of the units in the downstream of the branch joints on both lines is 240 or above use two branch joints (CMY-Y302S-G2).

Table4-2. See the table below for the first joint of the heat source unit described below.

heat source unit model	Joint model
P144 to P240	CMY-Y202S-G2

Table5. Header selection rule

Total down-stream Indoor capacity	4-branch Header	8-branch Header	10-branch Header
	CMY-Y104C-G	CMY-Y108C-G	CMY-Y1010C-G
<=P72	<=P144	<=P240	<=P240

* CMY-Y104C-G can directly connect PQHY-P72ZSKMU, but can NOT directly connect PQHY-P96ZSKMU or above;
 * CMY-Y108C-G can directly connect PQHY-P72~168Z(S)KMU, but can NOT directly connect PQHY-P192ZSKMU or above;
 * CMY-Y1010C-G can directly connect PQHY-P72~240Z(S)KMU;
 * CMY-Y104C-G can NOT connect P72~P96 Indoor, but CMY-Y108, Y1010C-G can do;
 * Concerning detailed usage of Header parts, refer to its Installation Manual.

Note3. Indoor capacity is described as its model size;
 For example, PEFY-P06NMAU-E3, its capacity is P06;
 Note4. Total down-stream Indoor capacity is the summary of the model size of Indoors downstream.
 For example, PEFY-P06NMAU-E3+PEFY-P08NMAU-E3: Total Indoor capacity=P06+P08=P14
 Note5. Piping sized determined by the Total down-stream indoor capacity is NOT necessary to be bigger than the up-stream one.
 i.e. A>=B; A>=C>=D

S.D. WY 575V

3-2-3. PQHY-P264-360ZSKMU Piping

Note1. No joint after Header; Piping direct to Indoor Unit from Header;
 Note2. As bents cause pressure loss on transportation of refrigerant, fewer bents design is better;
 Piping length needs to consider the actual length and equivalent length which bents are counted.
 Equivalent piping length (m)=Actual piping length+"M" x Quantity of bent.

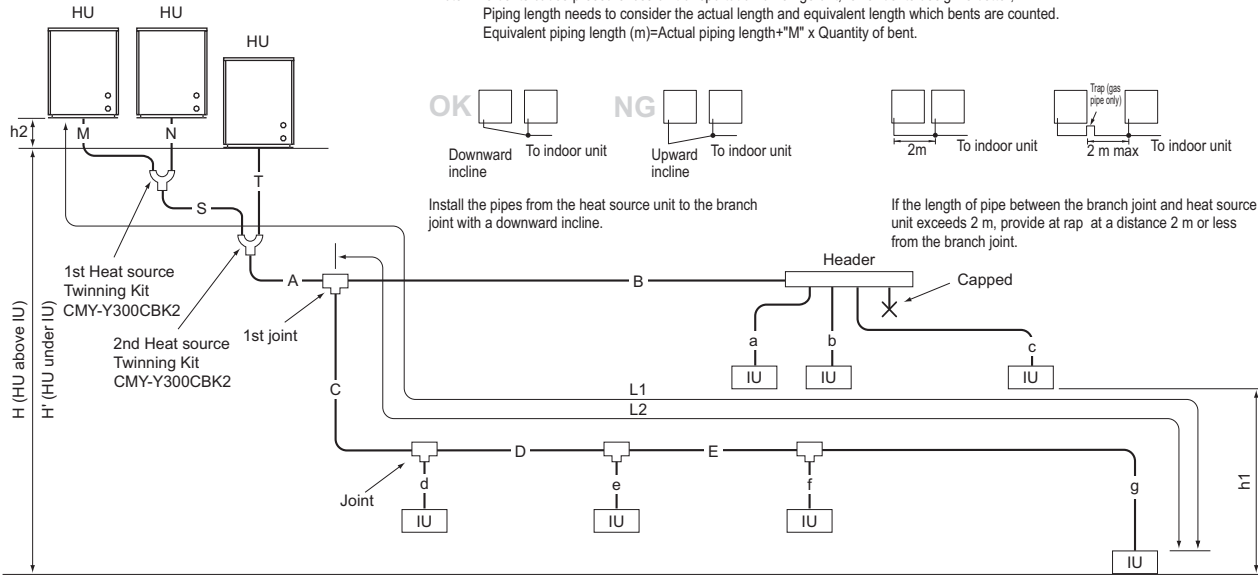

Fig. 3-2-1C Piping scheme

IU : Indoor unit , HU : Heat source unit

Piping length	Item	Piping in the figure	(m [ft.])		Bends equivalent length "M"	
			Max. length	Max. equivalent length	Heat source Model	M (m/bends [ft./bends])
Total piping length	S+T+M+N+A+B+C+D+E+a+b+c+d+e+f+g	500[1640]	-	PQHY-P264ZSKMU	0.70 [2.29]	
Distance between HU and HU	M+N+S+T	10[32]	-	PQHY-P288ZSKMU	0.70 [2.29]	
Height between HU and HU	h2	0.1[0.3]	-	PQHY-P312ZSKMU	0.70 [2.29]	
Farthest IU from HU (L1)	M(N)+S+A+C+D+E+g / M(N)+S+A+B+c	165[541]	190[623]	PQHY-P336ZSKMU	0.80 [2.62]	
Farthest IU from the first joint (L2)	C+D+E+g / B+c	40[131]	40[131]	PQHY-P360ZSKMU	0.80 [2.62]	
Height between HU and IU (HU above IU)	H	50[164]	-			
Height between HU and IU (HU under IU)	H'	40[131]	-			
Height between IU and IU	h1	15[49]	-			

HU: Heat source Unit, IU: Indoor Unit

Table1. Piping "A" size selection rule (mm [in.])

Heat source unit	Pipe(Liquid)	Pipe(Gas)
PQHY-P264-312ZSKMU	ø19.05[3/4]	ø34.93[1-3/8]
PQHY-P336,360ZSKMU	ø19.05[3/4]	ø41.28[1-5/8]

For Piping size "M", "N", "S", "T", please refer to specification of the Twinning kit CMY-Y300CBK2 at the Heat source unit's external drawing.

Table2. Piping "B", "C", "D", "E" size selection rule (mm [in.])

Total down-stream Indoor capacity	Pipe(Liquid)	Pipe(Gas)
~ P54	ø9.52 [3/8]	ø15.88 [5/8]
P55 ~ P72	ø9.52 [3/8]	ø19.05 [3/4]
P73 ~ P108	ø9.52 [3/8]	ø22.20 [7/8]
P109 ~ P144	ø12.70 [1/2]	ø28.58 [1-1/8]
P145 ~ P240	ø15.88 [5/8]	ø28.58 [1-1/8]
P241 ~ P308	ø19.05 [3/4]	ø34.93 [1-3/8]
P309 ~	ø19.05 [3/4]	ø41.28 [1-5/8]

Table3. Piping "a", "b", "c", "d", "e", "f", "g" size selection rule (mm [in.])

Indoor Unit size	Pipe(Liquid)	Pipe(Gas)
P06,P08,P12,P15,P18	ø6.35 [1/4]	ø12.70 [1/2]
P24,P27,P30,P36,P48,P54	ø9.52 [3/8]	ø15.88 [5/8]
P72	ø9.52 [3/8]	ø19.05 [3/4]
P96	ø9.52 [3/8]	ø22.20 [7/8]

Table4-1. Selection criteria for joints

Total down-stream Indoor capacity	Joint
~ P72	CMY-Y102SS-G2
P73 ~ P144	CMY-Y102LS-G2
P145 ~ P240	CMY-Y202S-G2
P241 ~	CMY-Y302S-G2

*The total capacity of the units in the downstream of the branch joint on at least one of the piping lines that are connected to the branch joint should be 240 or below.
 If the total capacity of the units in the downstream of the branch joints on both lines is 240 or above use two branch joints (CMY-Y302S-G2).
 *Concerning detailed usage of joint parts, refer to its Installation Manual.

Table4-2. See the table below for the first joint of the heat source unit described below.

heat source unit model	Joint model
P264 to P360	CMY-Y302S-G2

Table5. Header selection rule

	4-branch Header	8-branch Header	10-branch Header
	CMY-Y104C-G	CMY-Y108C-G	CMY-Y1010C-G
Total down-stream Indoor capacity	<=P72	<=P144	<=P240

* CMY-Y104C-G can directly connect PQHY-P72ZSKMU, but can NOT directly connect PQHY-P96ZSKMU or above;
 * CMY-Y108C-G can directly connect PQHY-P72-168Z(S)KMU, but can NOT directly connect PQHY-P192ZSKMU or above;
 * CMY-Y1010C-G can directly connect PQHY-P72-240Z(S)KMU;
 * CMY-Y104C-G can NOT connect P72-P96 Indoor, but CMY-Y108, Y1010C-G can do;
 * Concerning detailed usage of Header parts, refer to its Installation Manual.

Note3. Indoor capacity is described as its model size;
 For example, PEFY-P06NMAU-E3, its capacity is P06;
 Note4. Total down-stream Indoor capacity is the summary of the model size of Indoors downstream.
 For example, PEFY-P06NMAU-E3+PEFY-P08NMAU-E3: Total Indoor capacity=P06+P08=P14
 Note5. Piping sized determined by the Total down-stream indoor capacity is NOT necessary to be bigger than the up-stream one.
 i.e. A>=B; A>=C>=D

3-3. Refrigerant charging calculation

At the time of shipping, the heat source unit is charged with the refrigerant. As this charge does not include the amount needed for extended piping, additional charging for each refrigerant line will be required on site. In order that future servicing may be properly provided, always keep a record of the size and length of each refrigerant line and the amount of additional charge by writing it in the space provided on the heat source unit.

(1) Calculation of additional refrigerant charge

- Calculate the amount of additional charge based on the length of the piping extension and the size of the refrigerant line.
- Use the table to the below as a guide to calculating the amount of additional charging and charge the system accordingly.
 - * When connecting PLFY-P08NBMU-E2, add 0.3kg (10.6 oz) of refrigerant per indoor unit.
- If the calculation results in a fraction of less than 0.1kg[1oz], round up to the next 0.1kg[1oz]. For example, if the result of the calculation was 12.38kg[435.1oz], round the result up to 12.4kg[436oz].

<Additional Charge>

$$\begin{array}{|c|} \hline \text{Additional} \\ \text{refrigerant} \\ \text{charge} \\ \hline \text{(kg)} \\ \text{(oz)} \\ \hline \end{array} = \begin{array}{|c|} \hline \text{Total length of liquid} \\ \text{pipe sized } \phi 19.05 \text{ [3/4"} \\ \hline \text{(m) } \times 0.29 \text{ (kg/m)} \\ \text{(ft.) } \times 3.1 \text{ [oz/ft.]} \\ \hline \end{array} + \begin{array}{|c|} \hline \text{Total length of liquid} \\ \text{pipe sized } \phi 15.88 \text{ [5/8"} \\ \hline \text{(m) } \times 0.20 \text{ (kg/m)} \\ \text{(ft.) } \times 2.15 \text{ [oz/ft.]} \\ \hline \end{array} + \begin{array}{|c|} \hline \text{Total length of liquid} \\ \text{pipe sized } \phi 12.7 \text{ [1/2"} \\ \hline \text{(m) } \times 0.12 \text{ (kg/m)} \\ \text{(ft.) } \times 1.29 \text{ [oz/ft.]} \\ \hline \end{array} + \begin{array}{|c|} \hline \text{Total length of liquid} \\ \text{pipe sized } \phi 9.52 \text{ [3/8"} \\ \hline \text{(m) } \times 0.06 \text{ (kg/m)} \\ \text{(ft.) } \times 0.65 \text{ [oz/ft.]} \\ \hline \end{array} + \begin{array}{|c|} \hline \text{Total length of liquid} \\ \text{pipe sized } \phi 6.35 \text{ [1/4"} \\ \hline \text{(m) } \times 0.024 \text{ (kg/m)} \\ \text{(ft.) } \times 0.26 \text{ [oz/ft.]} \\ \hline \end{array} + \alpha$$

Table3-2-4-1. Value of α

Total capacity of connecting indoor units	α	
Models ~ 27	2.0 kg	[71 oz]
Models 28 ~ 54	2.5 kg	[89 oz]
Models 55 ~ 126	3.0 kg	[106 oz]
Models 127 ~ 144	3.5 kg	[124 oz]
Models 145 ~ 180	4.5 kg	[160 oz]
Models 181 ~ 234	5.0 kg	[177 oz]
Models 235 ~ 273	6.0 kg	[212 oz]
Models 274 ~ 307	8.0 kg	[283 oz]
Models 308 ~ 342	9.0 kg	[318 oz]
Models 343 ~ 411	10.0 kg	[353 oz]
Models 412 ~ 480	12.0 kg	[424 oz]
Models 481 ~	14.0 kg	[494 oz]

Example: PQHY-P120ZKMU

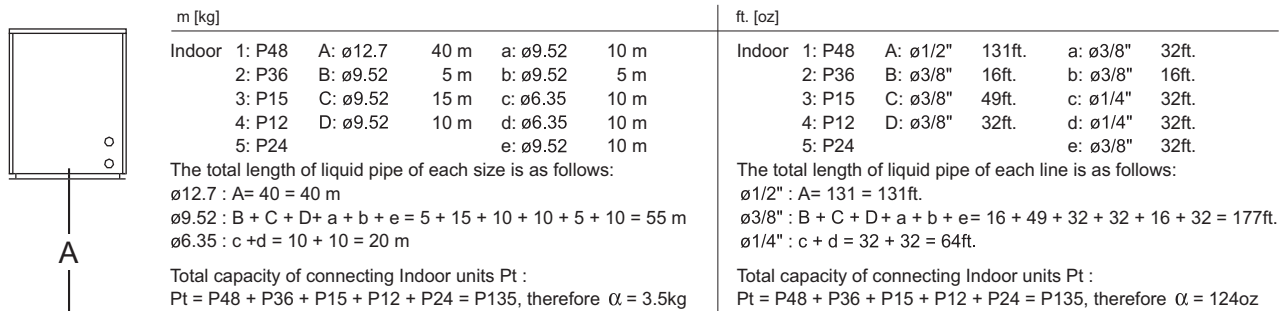

$$\begin{array}{|c|} \hline \text{Additional} \\ \text{refrigerant} \\ \text{charge} \\ \hline \text{(kg)} \\ \hline \end{array} = \begin{array}{|c|} \hline \text{Total length of liquid} \\ \text{pipe sized } \phi 19.05 \\ \hline \times 0.29 \text{ (kg/m)} \\ \hline \text{0 (m) } \times 0.29 \text{ (kg/m)} \\ \hline \end{array} + \begin{array}{|c|} \hline \text{Total length of liquid} \\ \text{pipe sized } \phi 15.88 \\ \hline \times 0.20 \text{ (kg/m)} \\ \hline \text{0 (m) } \times 0.20 \text{ (kg/m)} \\ \hline \end{array} + \begin{array}{|c|} \hline \text{Total length of liquid} \\ \text{pipe sized } \phi 12.7 \\ \hline \times 0.12 \text{ (kg/m)} \\ \hline \text{40 (m) } \times 0.12 \text{ (kg/m)} \\ \hline \end{array} + \begin{array}{|c|} \hline \text{Total length of liquid} \\ \text{pipe sized } \phi 9.52 \\ \hline \times 0.06 \text{ (kg/m)} \\ \hline \text{55 (m) } \times 0.06 \text{ (kg/m)} \\ \hline \end{array} + \begin{array}{|c|} \hline \text{Total length of liquid} \\ \text{pipe sized } \phi 6.35 \\ \hline \times 0.024 \text{ (kg/m)} \\ \hline \text{20 (m) } \times 0.024 \text{ (kg/m)} \\ \hline \end{array} + 3.5$$

$$= 0 + 0 + 40 \times 0.12 + 55 \times 0.06 + 20 \times 0.024 + 3.5 = 12.1 \text{ kg}$$

or

$$\begin{array}{|c|} \hline \text{Additional} \\ \text{refrigerant} \\ \text{charge} \\ \hline \text{(oz)} \\ \hline \end{array} = \begin{array}{|c|} \hline \text{Total length of liquid} \\ \text{pipe sized } \phi 3/4" \\ \hline \times 3.1 \text{ (oz/ft.)} \\ \hline \text{0 (ft.) } \times 3.1 \text{ (oz/ft.)} \\ \hline \end{array} + \begin{array}{|c|} \hline \text{Total length of liquid} \\ \text{pipe sized } \phi 5/8" \\ \hline \times 2.15 \text{ (oz/ft.)} \\ \hline \text{0 (ft.) } \times 2.15 \text{ (oz/ft.)} \\ \hline \end{array} + \begin{array}{|c|} \hline \text{Total length of liquid} \\ \text{pipe sized } \phi 1/2" \\ \hline \times 1.29 \text{ (oz/ft.)} \\ \hline \text{131 (ft.) } \times 1.29 \text{ (oz/ft.)} \\ \hline \end{array} + \begin{array}{|c|} \hline \text{Total length of liquid} \\ \text{pipe sized } \phi 3/8" \\ \hline \times 0.65 \text{ (oz/ft.)} \\ \hline \text{177 (ft.) } \times 0.65 \text{ (oz/ft.)} \\ \hline \end{array} + \begin{array}{|c|} \hline \text{Total length of liquid} \\ \text{pipe sized } \phi 1/4" \\ \hline \times 0.26 \text{ (oz/ft.)} \\ \hline \text{64 (ft.) } \times 0.26 \text{ (oz/ft.)} \\ \hline \end{array} + 124$$

$$= 0 + 0 + 131 \times 1.29 + 177 \times 0.65 + 64 \times 0.26 + 124 = 425 \text{ [oz]}$$

4-1. General requirements for installation

1. If possible, locate the unit to reduce the direct thermal radiation to the unit.
2. Consider the amount of noise the unit produces when choosing an installation location.
Valves and refrigerant flow on the outdoor/heat source unit may generate noise.
3. Avoid sites that may encounter strong winds.
4. Ensure the installation site can bear the weight of the unit.
5. Condensation should be moved away from the unit, particularly in heating mode.
6. Provide enough space for installation and service as shown in section .
7. Avoid sites where acidic solutions or chemical sprays (such as sulfur sprays) are used frequently.
8. The unit should be provided from combustible gas, oil, steam, chemical gas like acidic solution, sulfur gas and so on.

4-2. Spacing

In case of single installation, 600mm or more of back space as front space makes easier access when servicing the unit from rear side.

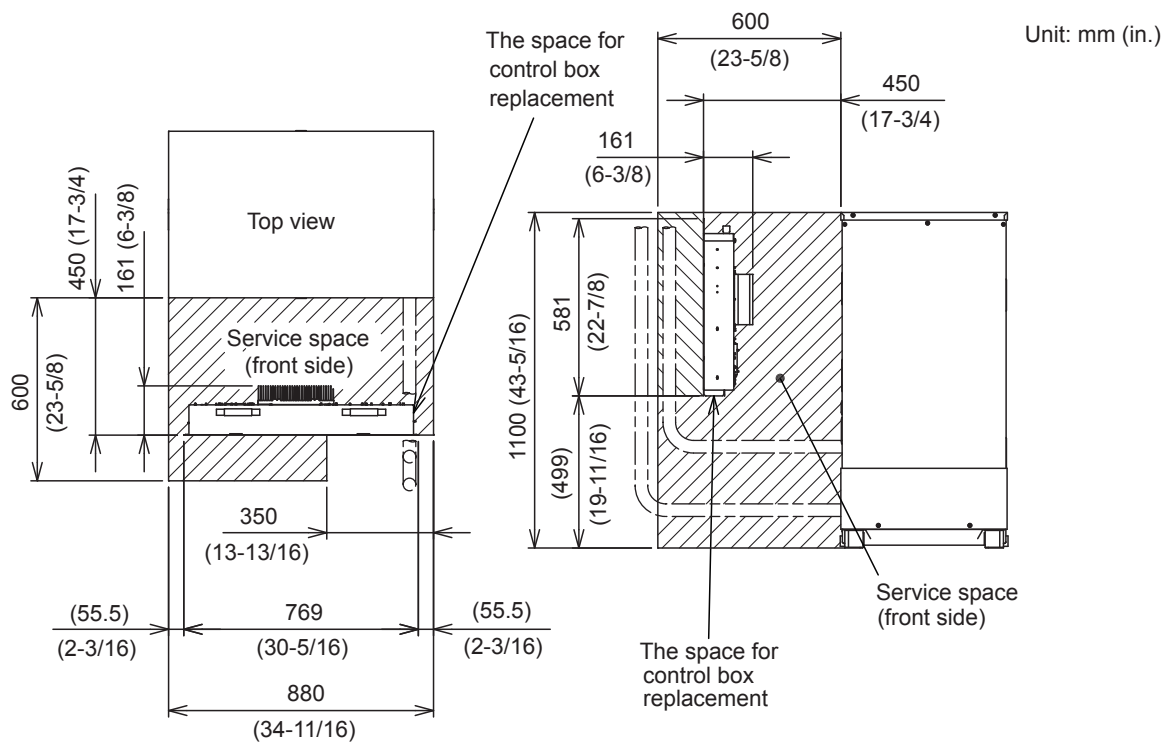

4-3. Caution on selecting heat source unit

Consult your dealer when the following issues on WY series are the key concern.

- Warm air may flow out from the indoor unit during heating Thermo-OFF.
- Refrigerant flow sound may occur in the rooms with low background noise such as hotel rooms, hospital rooms, bedrooms, or conference rooms.

To avoid the above issues on WY series, changing board settings on the indoor and outdoor units is required. Ask AC&R Works for details.

4-4. Piping direction

<Model : PQHY, PQRV-P-ZKMU-A>

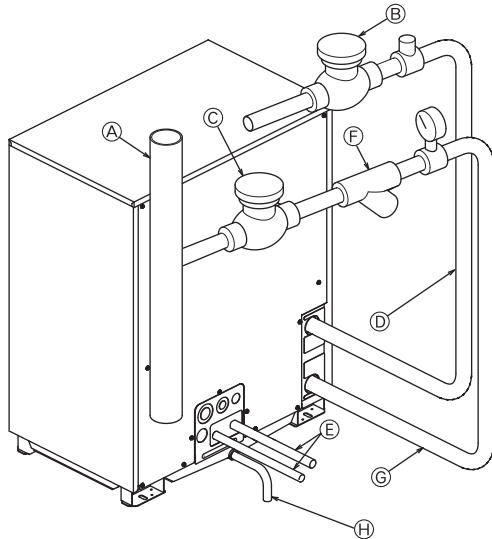

- (A) Main circulating water pipe
- (B) Shutoff valve
- (C) Shutoff valve
- (D) Water outlet (upper)
- (E) Refrigerant pipes
- (F) Y-type strainer
- (G) Water inlet (lower)
- (H) Drain pipe

1. Insulation installation

With City Multi WY/ WR2 Series piping, as long as the temperature range of the circulating water is kept to average temperatures year-round (29.4°C[85°F] in the summer, 21.1°C[70°F] in the winter), there is no need to insulate or otherwise protect indoor piping from exposure. You should use insulation in the following situations:

- Any heat source piping.
- Indoor piping in cold-weather regions where frozen pipes are a problem.
- When air coming from the outside causes condensation to form on piping.
- Any drainage piping.

2. Water processing and water quality control

To preserve water quality, use the closed type of cooling tower for WY/ WR2. When the circulating water quality is poor, the water heat exchanger can develop scales, leading to a reduction in heat-exchange power and possible corrosion of the heat exchanger. Please pay careful attention to water processing and water quality control when installing the water circulation system.

- Removal of foreign objects or impurities within the pipes. During installation, be careful that foreign objects, such as welding fragments, sealant particles, or rust, do not enter the pipes.
- Water Quality Processing
 - ① Depending on the quality of the cold-temperature water used in the air conditioner, the copper piping of the heat exchanger may become corroded. We recommend regular water quality processing. Cold water circulation systems using open heat storage tanks are particularly prone to corrosion. When using an open-type heat storage tank, install a water-to-water heat exchanger, and use a closed-loop circuit on the air conditioner side. If a water supply tank is installed, keep contact with air to a minimum, and keep the level of dissolved oxygen in the water no higher than 1mg/ℓ.

② Water quality standard

Items	Lower mid-range temperature water system		Tendency		
	Recirculating water [20<T<60°C] [68<T<140°F]	Make-up water	Corrosive	Scale-forming	
Standard items	pH (25°C)[77°F]	7.0 ~ 8.0	7.0 ~ 8.0	○	○
	Electric conductivity (mS/m) (25°C)[77°F]	30 or less	30 or less	○	○
	(μS/cm) (25°C)[77°F]	[300 or less]	[300 or less]		
	Chloride ion (mg Cl/ℓ)	50 or less	50 or less	○	
	Sulfate ion (mg SO ₄ ²⁻ /ℓ)	50 or less	50 or less	○	
	Acid consumption (pH4.8) (mg CaCO ₃ /ℓ)	50 or less	50 or less		○
	Total hardness (mg CaCO ₃ /ℓ)	70 or less	70 or less		○
Reference items	Calcium hardness (mg CaCO ₃ /ℓ)	50 or less	50 or less		○
	Ionic silica (mg SiO ₂ /ℓ)	30 or less	30 or less		○
	Iron (mg Fe/ℓ)	1.0 or less	0.3 or less	○	○
	Copper (mg Cu/ℓ)	1.0 or less	0.1 or less	○	
	Sulfide ion (mg S ²⁻ /ℓ)	not to be detected	not to be detected	○	
	Ammonium ion (mg NH ₄ ⁺ /ℓ)	0.3 or less	0.1 or less	○	
	Residual chlorine (mg Cl/ℓ)	0.25 or less	0.3 or less	○	
Free carbon dioxide (mg CO ₂ /ℓ)	0.4 or less	4.0 or less	○		
Ryzner stability index	-	-	○	○	

Reference : Guideline of Water Quality for Refrigeration and Air Conditioning Equipment. (JRA GL02E-1994)

- ③ Please consult with a water quality control specialist about water quality control methods and water quality calculations before using anti-corrosive solutions for water quality management.
- ④ When replacing a previously installed air conditioning device (even when only the heat exchanger is being replaced), first conduct a water quality analysis and check for possible corrosion. Corrosion can occur in cold-water systems even if there has been no prior signs of corrosion. If the water quality level has dropped, please adjust water quality sufficiently before replacing the unit.

S.D. WY 575V

CITY MULTI

INSTALLATION INFORMATION

1. Installation information	4 - 470
1-1.General precautions	4 - 470
1-2.Precautions for Indoor unit and BC controller.....	4 - 472
1-3.Precautions for Outdoor unit/Heat source unit	4 - 473
1-4.Precautions for Control-related items	4 - 474

1-1. General precautions

1-1-1. Usage

- The air-conditioning system described in this Data Book is designed for human comfort.
- This product is not designed for preservation of food, animals, plants, precision equipment, or art objects. To prevent quality loss, do not use the product for purposes other than what it is designed for.
- To reduce the risk of water leakage and electric shock, do not use the product for air-conditioning vehicles or vessels.

1-1-2. Installation environment

- Do not install any unit other than the dedicated unit in a place where the voltage changes a lot, large amounts of mineral oil (e.g., cutting oil) are present, cooking oil may splash, or a large quantity of steam can be generated such as a kitchen.
- Do not install the unit in acidic or alkaline environment.
- Installation should not be performed in the locations exposed to chlorine or other corrosive gases. Avoid near a sewer.
- To reduce the risk of fire, do not install the unit in a place where flammable gas may be leaked or inflammable material is present.
- This air conditioning unit has a built-in microcomputer. Take the noise effects into consideration when deciding the installation position. Especially in a place where antenna or electronic device are installed, it is recommended that the air conditioning unit be installed away from them.
- Install the unit on a solid foundation according to the local safety measures against typhoons, wind gusts, and earthquakes to prevent the unit from being damaged, toppling over, and falling.

1-1-3. Backup system

- In a place where air conditioner's malfunctions may exert crucial influence, it is recommended to have two or more systems of single outdoor/heat source units with multiple indoor units.

1-1-4. Unit characteristics

- Heat pump efficiency of outdoor unit depends on outdoor temperature. In the heating mode, performance drops as the outside air temperature drops. In cold climates, performance can be poor. Warm air would continue to be trapped near the ceiling and the floor level would continue to stay cold. In this case, heat pumps require a supplemental heating system or air circulator. Before purchasing them, consult your local distributor for selecting the unit and system.
- When the outdoor temperature is low and the humidity is high, the heat exchanger on the outdoor unit side tends to collect frost, which reduces its heating performance. To remove the frost, Auto-defrost function will be activated and the heating mode will temporarily stop for 3-10 minutes. Heating mode will automatically resume upon completion of defrost process.
- Air conditioner with a heat pump requires time to warm up the whole room after the heating operation begins, because the system circulates warm air in order to warm up the whole room.
- The sound levels were obtained in an anechoic room. The sound levels during actual operation are usually higher than the simulated values due to ambient noise and echoes. Refer to the section on "SOUND LEVELS" for the measurement location.
- Depending on the operation conditions, the unit generates noise caused by valve actuation, refrigerant flow, and pressure changes even when operating normally. Please consider to avoid location where quietness is required. For BC/HBC controller, it is recommended to unit to be installed in places such as ceilings of corridor, restrooms and plant rooms.
- The total capacity of the connected indoor units can be greater than the capacity of the outdoor/heat source unit. However, when the connected indoor units operate simultaneously, each unit's capacity may become smaller than the rated capacity.
- When the unit is started up for the first time within 12 hours after power on or after power failure, it performs initial startup operation (capacity control operation) to prevent damage to the compressor. The initial startup operation requires 90 minutes maximum to complete, depending on the operation load.

1-1-5. Relevant equipment

- Use an earth leakage breaker (ELB) with medium sensitivity, and an activation speed of 0.1 second or less.
- Consult your local distributor or a qualified technician when installing an earth leakage breaker.
- If the unit is inverter type, select an earth leakage breaker for handling high harmonic waves and surges.
- Leakage current is generated not only through the air conditioning unit but also through the power wires. Therefore, the leakage current of the main power supply is greater than the total leakage current of each unit. Take into consideration the capacity of the earth leakage breaker or leakage alarm when installing one at the main power supply. To measure the leakage current simply on site, use a measurement tool equipped with a filter, and clamp all the four power wires together. The leakage current measured on the ground wire may not accurate because the leakage current from other systems may be included to the measurement value.
- Do not install a phase advancing capacitor on the unit connected to the same power system with an inverter type unit and its equipment.
- If a large current flows due to the product malfunctions or faulty wiring, both the earth leakage breaker on the product side and the upstream overcurrent breaker may trip almost at the same time. Separate the power system or coordinate all the breakers depending on the system's priority level.

1-1-6. Unit installation

- ♦Your local distributor or a qualified technician must read the Installation Manual that is provided with each unit carefully before performing installation work.
- ♦Consult your local distributor or a qualified technician when installing the unit. Improper installation by an unqualified person may result in water leakage, electric shock, or fire.
- ♦Ensure there is enough space around each unit.

1-1-7. Optional accessories

- ♦Only use accessories recommended by Mitsubishi Electric. Consult your local distributor or a qualified technician when installing them. Improper installation by an unqualified person may result in water leakage, electric leakage, system breakdown, or fire.
- ♦Some optional accessories may not be compatible with the air conditioning unit to be used or may not be suitable for the installation conditions. Check the compatibility when considering any accessories.
- ♦Note that some optional accessories may affect the air conditioner's external form, appearance, weight, operating sound, and other characteristics.

1-1-8. Operation/Maintenance

- ♦Read the Instruction Book that is provided with each unit carefully prior to use.
- ♦Maintenance or cleaning of each unit may be risky and require expertise. Read the Instruction Book to ensure safety. Consult your local distributor or a qualified technician when special expertise is required such as when the indoor unit needs to be cleaned.

1-2. Precautions for Indoor unit and BC controller

1-2-1. Operating environment

- The refrigerant (R410A) used for air conditioner is non-toxic and nonflammable. However, if the refrigerant leaks, the oxygen level may drop to harmful levels. If the air conditioner is installed in a small room, measures must be taken to prevent the refrigerant concentration from exceeding the safety limit even if the refrigerant should leak.
- If the units operate in the cooling mode at the humidity above 80%, condensation may collect and drip from the indoor units.

1-2-2. Unit characteristics

- The return air temperature display on the remote controller may differ from the ones on the other thermometers.
- The clock on the remote controller may be displayed with a time lag of approximately one minute every month.
- The temperature using a built-in temperature sensor on the remote controller may differ from the actual room temperature due to the effect of the wall temperature.
- Use a built-in thermostat on the remote controller or a separately-sold thermostat when indoor units installed on or in the ceiling operate the automatic cooling/heating switchover.
- The room temperature may rise drastically due to Thermo OFF in the places where the air conditioning load is large such as computer rooms.
- Be sure to use a regular filter. If an irregular filter is installed, the unit may not operate properly, and the operation noise may increase.
- The room temperature may rise over the preset temperature in the environment where the heating air conditioning load is small.

1-2-3. Unit installation

- For simultaneous cooling/heating operation type air conditioners (R2, H2i R2, WR2 series), the G-type BC controller cannot be connected to the P144 outdoor/heat source unit model or above, and the G- and GA-type BC controllers cannot be connected to the P264 model or above. The GB- and HB-type BC controllers (sub) cannot be connected to the outdoor/heat source unit directly, and be sure to use them with GA- and HA-type BC controllers (main).
- The insulation for low pressure pipe between the BC controller and outdoor/heat source unit shall be at least 20 mm thick. If the unit is installed on the top floor or in a high-temperature, high-humidity environment, thicker insulation may be necessary.
- Do not have any branching points on the downstream of the refrigerant pipe header.
- When a field-supplied external thermistor is installed or when a device for the demand control is used, abnormal stop of the unit or damage of the electromagnetic contactor may occur. Consult your local distributor for details.
- When indoor units operate a fresh air intake, install a filter in the duct (field-supplied) to remove the dust from the air.
- The 4-way or 2-way Airflow Ceiling Cassette Type units that have an outside air inlet can be connected to the duct, but need a booster fan to be installed at site. Refer to the chapter "Indoor Unit" for the available range for fresh air intake volume.
- Operating fresh air intake on the indoor unit may increase the sound pressure level.

1-3. Precautions for Outdoor unit/Heat source unit

1-3-1. Installation environment

- ♦Outdoor/heat source unit with salt-resistant specification is recommended to use in a place where it is subject to salt air.
 - ♦Even when the unit with salt-resistant specification is used, it is not completely protected against corrosion. Be sure to follow the directions or precautions described in Instructions Book and Installation Manual for installation and maintenance. The salt-resistant specification is referred to the guidelines published by JRAIA (JRA9002).
 - ♦Install the unit in a place where the flow of discharge air is not obstructed. If not, the short-cycling of discharge air may occur.
 - ♦Provide proper drainage around the unit base, because the condensation may collect and drip from the outdoor/heat source units. Provide water-proof protection to the floor when installing the units on the rooftop.
 - ♦In a region where snowfall is expected, install the unit so that the outlet faces away from the direction of the wind, and install a snow guard to protect the unit from snow. Install the unit on a base approximately 50 cm higher than the expected snowfall. Close the openings for pipes and wiring, because the ingress of water and small animals may cause equipment damage. If SUS snow guard is used, refer to the Installation Manual that comes with the snow guard and take caution for the installation to avoid the risk of corrosion.
 - ♦When the unit is expected to operate continuously for a long period of time at outside air temperatures of below 0°C, take appropriate measures, such as the use of a unit base heater, to prevent icing on the unit base. (Not applicable to the PUMY-P-NHMu series)
 - ♦Install the snow guard so that the outlet/inlet faces away from the direction of the wind.
 - ♦When the snow accumulates approximately 50 cm or more on the snow guard, remove the snow from the guard. Install a roof that is strong enough to withstand snow loads in a place where snow accumulates.
 - ♦Provide proper protection around the outdoor/heat source units in places such as schools to avoid the risk of injury.
 - ♦A cooling tower and heat source water circuit should be a closed circuit that water is not exposed to the atmosphere. When a tank is installed to ensure that the circuit has enough water, minimize the contact with outside air so that the oxygen from being dissolved in the water should be 1 mg/L or less.
 - ♦Install a strainer (50 mesh or more recommended) on the water pipe inlet on the heat source unit.
 - ♦Interlock the heat source unit and water circuit pump.
 - ♦Note the followings to prevent the freeze bursting of pipe when the heat source unit is installed in a place where the ambient temperature can be 0°C or below.
 - ♦Keep the water circulating to prevent it from freezing when the ambient temperature is 0°C or below.
 - ♦Before a long period of non use, be sure to purge the water out of the unit.
 - ♦Salt-resistant unit is resistant to salt corrosion, but not salt-proof.
- Please note the following when installing and maintaining outdoor units in marine atmosphere.
1. Install the salt-resistant unit out of direct exposure to sea breeze, and minimize the exposure to salt water mist.
 2. Avoid installing a sun shade over the outdoor unit, so that rain will wash away salt deposits off the unit.
 3. Install the unit horizontally to ensure proper water drainage from the base of the unit. Accumulation of water in the base of the outdoor unit will significantly accelerate corrosion.
 4. Periodically wash salt deposits off the unit, especially when the unit is installed in a coastal area.
 5. Repair all noticeable scratches after installation and during maintenance.
 6. Periodically check the unit, and apply anti-rust agent and replace corroded parts as necessary.

1-3-2. Circulating water

- ♦Follow the guidelines published by JRAIA (JRA-GL02-1994) to check the water quality of the water in the heat source unit regularly.
- ♦A cooling tower and heat source water circuit should be a closed circuit that water is not exposed to the atmosphere. When a tank is installed to ensure that the circuit has enough water, minimize the contact with outside air so that the oxygen from being dissolved in the water should be 1 mg/L or less.

1-3-3. Unit characteristics

- ♦When the Thermo ON and OFF is frequently repeated on the indoor unit, the operation status of outdoor/heat source units may become unstable.

1-3-4. Relevant equipment

- ♦Provide grounding in accordance with the local regulations.

1-4. Precautions for Control-related items

1-4-1. Product specification

- To introduce the MELANS system, a consultation with us is required in advance. Especially to introduce the electricity charge apportioning function or energy-save function, further detailed consultation is required. Consult your local distributor for details.
- Billing calculation for AE-200A/AE-50A/EW-50A/AG-150A-A/EB-50GU-A/TG-2000A, or the billing calculation unit is unique and based on our original method. (Backup operation is included.) It is not based on the metering method, and do not use it for official business purposes. It is not the method that the amount of electric power consumption (input) by air conditioner is calculated. Note that the electric power consumption by air conditioner is apportioned by using the ratio corresponding to the operation status (output) for each air conditioner (indoor unit) in this method.
- In the apportioned billing function for AE-200A/AE-50A/EW-50A/AG-150A-A and EB-50GU-A, use separate watt-hour meters for A-control units, K-control units^{*1}, and packaged air conditioner for City Multi air conditioners. It is recommended to use an individual watt-hour meter for the large-capacity indoor unit (with two or more addresses).
- When using the peak cut function on the AE-200A/AE-50A/EW-50A/AG-150A-A or EB-50GU-A, note that the control is performed once every minute and it takes time to obtain the effect of the control. Take appropriate measures such as lowering the criterion value. Power consumption may exceed the limits if AE-200A/AE-50A/EW-50A/AG-150A-A or EB-50GU-A malfunctions or stops. Provide a back-up remedy as necessary.
- The controllers cannot operate while the indoor unit is OFF. (No error)
Turn ON the power to the indoor unit when operating the controllers.
- When using the interlocked control function on the AE-200A/AE-50A/EW-50A/AG-150A-A/EB-50GU-A/PAC-YG66DCA or PAC-YG63MCA, do not use it for the control for the fire prevention or security. (This function should never be used in the way that would put people's lives at risk.) Provide any methods or circuit that allow ON/OFF operation using an external switch in case of failure.

1-4-2. Installation environment

- The surge protection for the transmission line may be required in areas where lightning strikes frequently occur.
- A receiver for a wireless remote controller may not work properly due to the effect of general lighting. Leave a space of at least 1 m between the general lighting and receiver.
- When the Auto-elevating panel is used and the operation is made by using a wired remote controller, install the wired remote controller to the place where all air conditioners controlled (at least the bottom part of them) can be seen from the wired remote controller. If not, the descending panel may cause damage or injury, and be sure to use a wireless remote controller designed for use with elevating panel (sold separately).
- Install the wired remote controller (switch box) to the place where the following conditions are met.
 - Where installation surface is flat
 - Where the remote controller can detect an accurate room temperature
The temperature sensors that detect a room temperature are installed both on the remote controller and indoor unit. When a room temperature is detected using the sensor on the remote controller, the main remote controller is used to detect a room temperature. In this case, follow the instructions below.
 - Install the controller in a place where it is not subject to the heat source.
(If the remote controller faces direct sunlight or supply air flow direction, the remote controller cannot detect an accurate room temperature.)
 - Install the controller in a place where an average room temperature can be detected.
 - Install the controller in a place where no other wires are present around the temperature sensor.
(If other wires are present, the remote controller cannot detect an accurate room temperature.)
- To prevent unauthorized access, always use a security device such as a VPN router when connecting AE-200A/AE-50A/EW-50A/AG-150A/EB-50GU-A or TG-2000A to the Internet.

*1.EB-50GU-A, AE-200A, AE-50A, and EW-50A cannot be used to control K-control units.

CITY MULTI

CAUTION FOR REFRIGERANT LEAKAGE

1. Caution for refrigerant leakage	4 - 476
1-1.Refrigerant property	4 - 476
1-2.Confirm the Critical concentration and take countermeasure.....	4 - 476

The installer and/or air conditioning system specialist shall secure safety against refrigerant leakage according to local regulations or standards. The following standard may be applicable if no local regulation or standard is available.

1-1. Refrigerant property

R410A refrigerant is harmless and incombustible. The R410A is heavier than the indoor air in density. Leakage of the refrigerant in a room has possibility to lead to a hypoxia situation. Therefore, the critical concentration specified below shall not be exceeded even if the leakage happens.

• Critical concentration

Critical concentration hereby is the refrigerant concentration in which no human body would be hurt if immediate measures can be taken when refrigerant leakage happens.

Critical concentration of R410A: 0.44kg/m³
(The weight of refrigeration gas per 1 m³ air conditioning space.);

* The Critical concentration is subject to ISO5149, EN378-1.

For the CITY MULTI system, the concentration of refrigerant leaked should not have a chance to exceed the critical concentration in any situation.

1-2. Confirm the Critical concentration and take countermeasure

The maximum refrigerant leakage concentration (Rmax) is defined as the result of the possible maximum refrigerant weight (Wmax) leaked into a room divided by its room capacity (V). It is referable to Fig.1-1. The refrigerant of Outdoor/Heat source unit here includes its original charge and additional charge at the site.

The additional charge is calculated according to the refrigerant charging calculation of each kind of Outdoor/Heat source unit, and shall not be over charged at the site. Procedure 1-2-1~3 tells how to confirm maximum refrigerant leakage concentration (Rmax) and how to take countermeasures against a possible leakage.

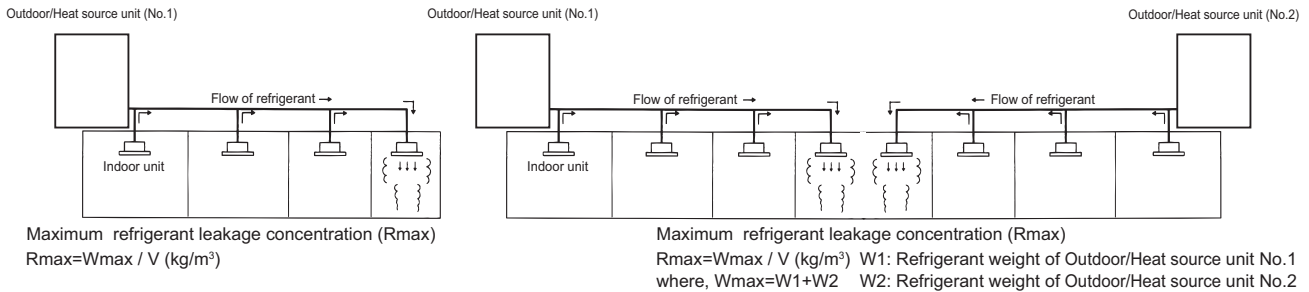

Fig. 1-1 The maximum refrigerant leakage concentration

1-2-1. Find the room capacity (V),

If a room having total opening area more than 0.15% of the floor area at a low position with another room/space, the two rooms/space are considered as one. The total space shall be added up.

1-2-2. Find the possible maximum leakage (Wmax) in the room. If a room has Indoor unit(s) from more than 1 Outdoor/Heat source unit, add up the refrigerant of the Outdoor/Heat source units.

1-2-3. Divide (Wmax) by (V) to get the maximum refrigerant leakage concentration (Rmax).

1-2-4. Find if there is any room in which the maximum refrigerant leakage concentration (Rmax) is over 0.44kg/m³.

If no, then the CITY MULTI is safe against refrigerant leakage.

If yes, following countermeasure is recommended to do at site.

Countermeasure 1: Let-out (making V bigger)

Design an opening of more than 0.15% of the floor area at a low position of the wall to let out the refrigerant whenever leaked. e.g. make the upper and lower seams of door big enough.

Countermeasure 2: Smaller total charge (making Wmax smaller)

e.g. Avoid connecting more than 1 Outdoor/Heat source unit to one room.
 e.g. Using smaller model size but more Outdoor/Heat source units.
 e.g. Shorten the refrigerant piping as much as possible.

Countermeasure 3: Fresh air in from the ceiling (Ventilation)

As the density of the refrigerant is bigger than that of the air. Fresh air supply from the ceiling is better than air exhausting from the ceiling. Fresh air supply solution refers to Fig.1-2~4.

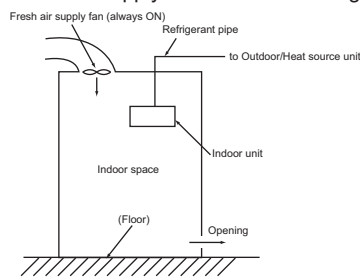

Fig.1-2. Fresh air supply always ON

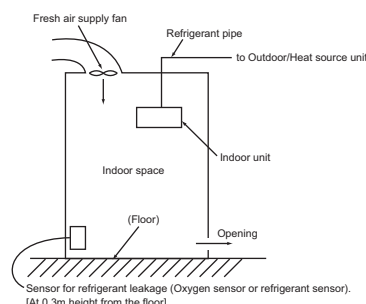

Fig.1-3. Fresh air supply upon sensor action

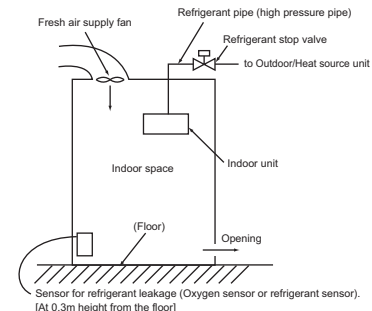

Fig.1-4. Fresh air supply and refrigerant shut-off upon sensor action

Note 1. Countermeasure 3 should be done in a proper way in which the fresh air supply shall be on whenever the leakage happens.

Note 2. In principle, MITSUBISHI ELECTRIC requires proper piping design, installation and air-tight testing after installation to avoid leakage happening. In the area should earthquake happen, anti-vibration measures should be fully considered.

The piping should consider the extension due to the temperature variation.