

MANUFACTURED FOR:
MITSUBISHI ELECTRIC US, INC.

Filter Boxes

FBM-Series

For use with: PEFY / PEAD Indoor Units

INSTALLATION MANUAL

FOR INSTALLER

For safe and correct use, please read this installation manual thoroughly before installing these component.



Table of Contents

1. Inspect Shipment	5
2. Safety Precautions	6
3. Specifications	8
3.1. FBM Series	8
4. For ease in installation, the filter box should be attached before the indoor unit is mounted	9
5. Converting the filter box from rear (as supplied) to bottom return	10

1. Inspect Shipment

Upon receipt of equipment, carefully inspect it for possible damage. Take special care to examine the unit if the carton is damaged. If damage is found, it should be noted on the carrier's freight bill. Damage claims should be filed with the carrier immediately. Claims of shortages should be filed with the seller within 5 days.

2. Safety Precautions

- Before installing the unit, make sure you read all the “Safety precautions”.
- The “Safety precautions” provide very important points regarding safety. Make sure you follow them.

Symbols used in the text



WARNING

Describes precautions that should be observed to prevent danger of injury or death to the user.



CAUTION

Describes precautions that should be observed to prevent damage to the unit.



WARNING

- Do not install it by yourself (customer). Ask dealer or authorized company to install the accessory.
- Incomplete installation could cause injury.
- When you notice exceptionally abnormal noise or vibration, stop operation and contact your dealer.



CAUTION

- Use proper safety equipment for the Installation work.
- Tighten all screws as specified in the instructions. Over tightening screws can cause damage to parts.
- Not following properly installation instructions may result in air flow not passing through the filters, causing poor performance and other problems.
- Do not place polyethylene bags in reach of young children. Putting them over the head will block breathing passages, which could result in suffocation.

DISPOSING OF THE UNIT

When you need to dispose of the unit or filters, consult your dealer, to dispose in accordance with local laws and regulations

3. Specifications

3.1. FBM Series

Filter Box Model	Used with		Filter Box Dimensions			Filter(s) Included		
	CITY MULTI®	P-SERIES	Height	Width	Depth	14" x 14" x 2"	14" x 20" x 2"	14" x 25" x 2"
FBM2-1-A	PEFY-P06, P08, P12NMAU-E*	--	10"	27-5/8"	13"			1
FBM2-2-A	PEFY-P15, P18NMAU-E*	PEAD-A09, A12, A15, 18AA*	10"	35-1/2"	13"	1	1	
FBM2-3-A	PEFY-P24, P27, P30NMAU-E*	PEAD-A24, 30AA*	10"	43-3/8"	13"		2	
FBM2-4-A	PEFY-P36, P48NMAU-E*	PEAD-A36, 42AA*	10"	55-1/8"	13"	1	2	
FBM2-5-A	PEFY-P54NMAU-E*	--	10"	63"	13"		3	

* All models (for PEFY: E, E2, etc. ; for PEAD: AA4, AA5, AA7, etc.)

4. For ease in installation, the filter box should be attached before the indoor unit is mounted

1. Remove the filter from the back of the indoor unit and dispose of it properly in accordance with local laws and regulations.
2. Open the filter box door and remove the filter(s). Remove the metal spacer by unscrewing it from above and below, then remove it, or slide it aside to avoid interferences.
3. Position the indoor unit and filter box as shown below, matching the top of the filter box to the top of the indoor unit.
4. With the screws included, secure the filter box to the indoor unit. Inserting the end screws first will line up the rest of the holes.
5. Once the remaining screws are set, reinstall the metal spacer securing it to the filter box. Skipping this step may result in air flow miss passing through the filters, causing a poor performance of the filter box.
6. Reinstall the filter(s) making sure the airflow direction is correct.
7. Reinstall the filter box door and mark the installation date on the label.
8. The indoor unit is now ready to be mounted.

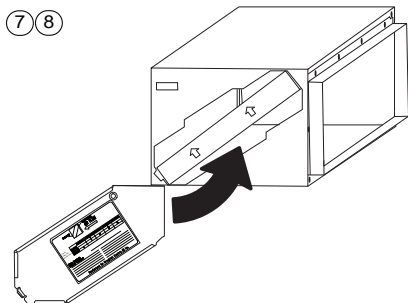
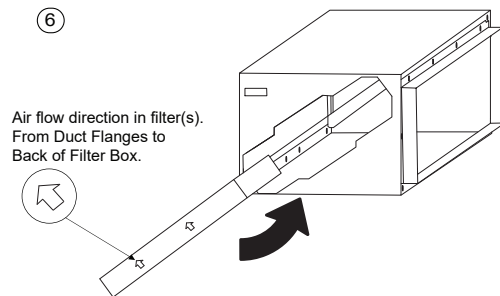
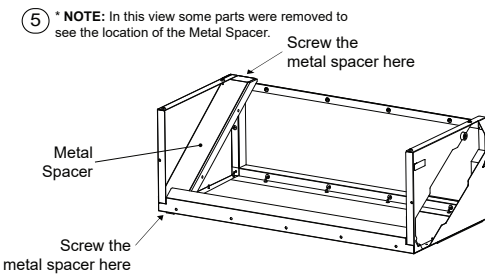
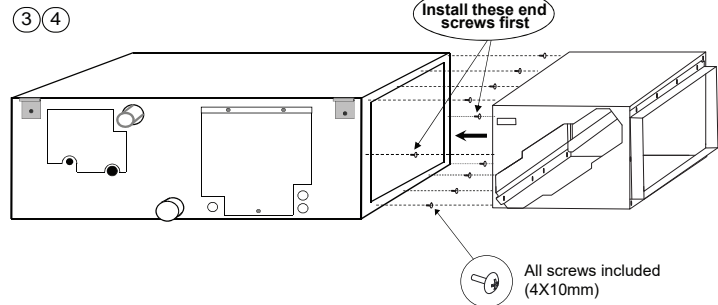
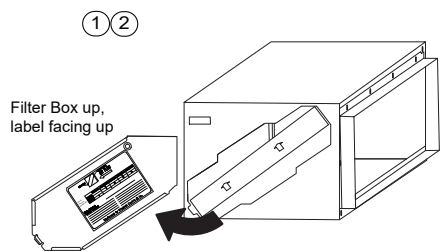

⚠ Warning

- When you notice exceptionally abnormal noise or vibration, stop operation and contact your dealer.

⚠ Caution

- Use proper safety equipment for the Installation work.
- Tighten all screws as specified in the instructions.
 - Over tightening screws can cause damage to parts.
- Not following properly installation instructions may result in air flow not passing through the filters, causing poor performance and other problems.

5. Converting the filter box from rear (as supplied) to bottom return

1. Remove rear duct flanges and bottom plate.
2. Install duct flanges on the bottom of the filter box.
3. Install the bottom plate on the rear of the filter box.

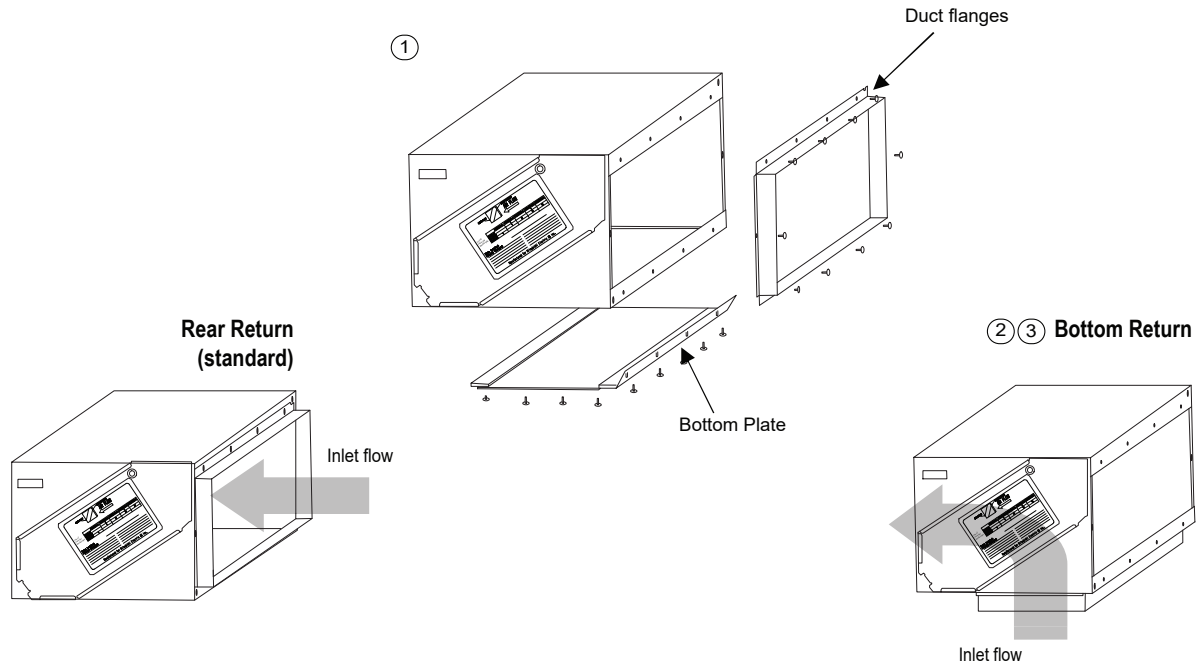

▲ Warning

- When you notice exceptionally abnormal noise or vibration, stop operation and contact your dealer.

⚠ Caution

- Use proper safety equipment for the Installation work.
- Tighten all screws as specified in the instructions.
 - Over tightening screws can cause damage to parts.
- Not following properly installation instructions may result in air flow not passing through the filters, causing poor performance and other problems.

This product is designed and intended for use in the residential, commercial and light-industrial environment.

Please be sure to put the contact address/telephone number on this manual before handing it to the customer.

Manufactured for:
MITSUBISHI ELECTRIC US, INC.

www.mitsubishielectric-usa.com

Toll Free: 800-433-4822