



Lossnay Signal Output Terminal

MODEL:

PZ-4GS-E

Installation and Instruction Manual

- This manual must be read both fully and carefully before commencing installation procedures; furthermore, the subsequent installation must be performed correctly and safely in accordance with the instructions given.
- Be sure to give this instruction manual to the customer once installation is complete.

1. Safety Precautions



WARNING

Incorrect handling could cause serious injury or death.

- Use a dedicated circuit for the equipment to be connected, and use the voltage and breaker appropriate for the connected load.
- Connected equipment should be used within the rated voltage and control capacity range.
- Never modify or repair by yourself.
If the product is modified or inappropriately repaired, electric shock, fire, etc. could result. Contact your dealer for repair.
- Do not move or reinstall the product by yourself.
If it is installed improperly, electric shock, fire, etc. could result. Contact your dealer or technical representative.
- Use the specified cables for wiring and connect them securely. Hold the cables so as not to apply external force of the cables to the Terminal block of this product.
Improper connection could result in heat generation or fire.
- All electrical work must be performed by a licensed technician, according to local regulations and the instructions given in this Installation manual.
- Ensure that installation work is done correctly following this Installation manual.
If it is installed improperly, electric shock, fire, etc. could result.
- Close the control cover after installation.
- Do not install the product in a place where flammable gases may leak.
If gas should leak or accumulate around the product, fire or explosion could result.
- Do not use the product in special environments.
The product could be damaged if it is used in locations subject to large quantities of oil (including machine oil), steam, or sulfide gas.
- Do not install the unit in a place where the temperature rises above 40 °C (104 °F), where large amounts of oil, steam, organic solvents, or corrosive gases, such as sulfuric gas, are present, or where acidic/alkaline solutions or sprays are used frequently.
These substances can compromise the performance of the unit or cause certain components of the unit to corrode, which can result in electric shock, malfunctions, smoke, or fire.



CAUTION

Incorrect handling could cause injury or damage to property or household effects.

- Wire so that it does not receive any tension.
Tension could cause wire breakage, heating or fire.
- Put on gloves during installation.
Failure to do so could cause injury.

2. Dimensional Outline Drawing

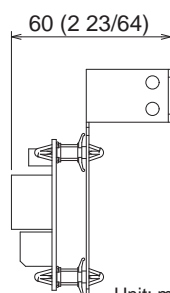
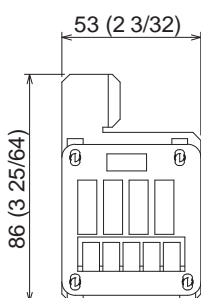

Unit: mm (inch)

■ Accessory Parts

 Installation screws (cross recessed truss screws M4 x 8): 2
 Connection cable (for connecting with the Lossnay unit): 1

Note:

- Do not damage the circuit board during unpacking.

3. Installation Method

Be sure to perform installation while the power of the Lossnay unit is OFF.

* Depending on the model of Lossnay or installation condition, the actual PCB and following diagram can be upside down.

3.1 Removing the Control Box Cover of the Lossnay Unit

For more information, please refer to the installation and operation manual of the Lossnay.

* Figures show the installation method of LGH-RVS series.

Remove the three black screws and remove the control box cover of the Lossnay unit.

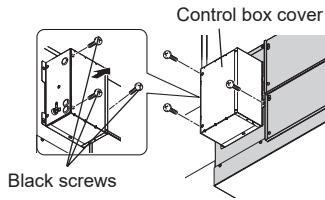

3.2 Installing PZ-4GS-E

Use the included installation screws (2) to install PZ-4GS-E to the PZ-4GS-E installation position on the side of the circuit board.

Note

- Be sure to use the included installation screws.
- Tighten the screws with a torque of $1.42 \pm 0.25 \text{ N} \cdot \text{m}$.
- During installation, be careful not to damage the Lossnay unit control board by tools or other objects.
- Connect the lead wires to the terminal blocks (TM2, TM3, TM4, TB5) before installing the PZ-4GS-E.

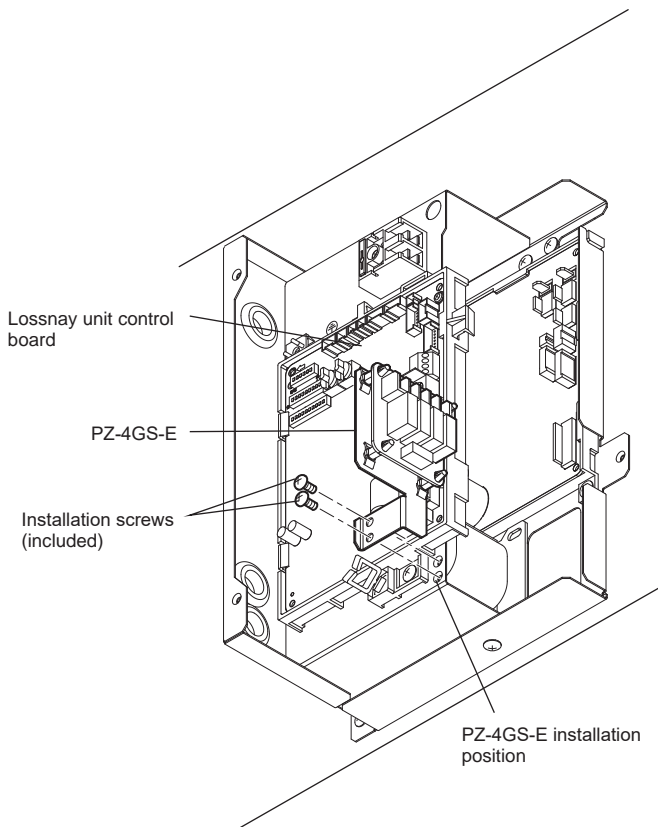

3.3 Connecting the Cable

Connect the connector (CN500) on the PZ-4GS-E to the connector (CN50) on the Lossnay unit control board using the included connection cable.

Note

- Insert the cable all the way until a locking sound is heard.
- Be sure not to apply force to the connector.

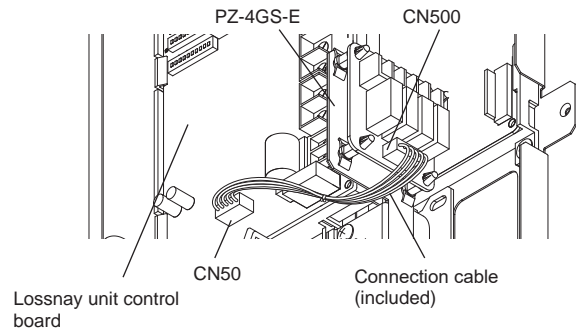

3.4 Wiring the External Device

- (1) Remove the bush on the Lossnay unit and install a cable gland (with two holes).
- (2) Pass the external device cable connected to PZ-4GS-E and the Lossnay unit power cable through the cable gland.
- (3) Wire the external device by reference to **Connection Diagram** on the next page.
Applicable cable: Multicore cable (strand wire, 0.5 mm^2 (AWG 20))

* The figure below shows an example of when a five-core cable is used.

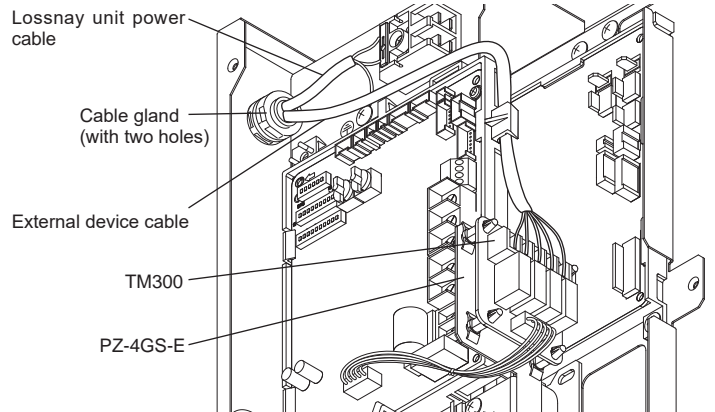

- (4) Wire the Lossnay unit power cable.
- (5) Attach the control box cover as it was before.

Note

- If wiring for the Lossnay unit has been already done, switch the cable gland from a one-hole cable gland to a two-hole cable gland and install the power cable along with it.
- Use a cable gland that falls within the applicable cable range.
- For wiring the Lossnay unit power cable, refer to the Lossnay unit installation and instruction manual.

4. Electrical Work

WARNING

- Use a dedicated circuit for the equipment to be connected, and use the voltage and breaker appropriate for the connected load.
- Connected equipment should be used within the rated voltage and control capacity range.
- All electrical work must be performed by a licensed technician, according to local regulations and the instructions given in the Installation manual.
- Use the specified cables for wiring and connect them securely. Hold the cables so as not to apply external force of the cables to the Terminal block of this product.

Lossnay operation, malfunction, By-pass ventilation, supply fan operation, exhaust fan operation, Pre-heater signal, and supply fan monitor output with delay operation (for after heater) signals can be output from the TM3 terminal of the Lossnay unit control board and the TM300 terminal of the PZ-4GS-E.

Connection terminal		PZ-62DR-E Function No.	Output*
Lossnay unit	TM3 ⑨ and ⑩	12	Operation monitor
PZ-4GS-E (TM300)	COM-OUT1	13	Malfunction monitor
	COM-OUT2	14	By-pass monitor
	COM-OUT3	15	Supply fan operation monitor
	COM-OUT4	16	Exhaust fan operation monitor

* Factory settings of Lossnay LGH-RVS series. The setting may differ according to the type of Lossnay series. Be sure to refer each Lossnay unit installation manual for detail setting.

The output signals from each terminal can be changed arbitrarily from PZ-62DR-E.

In order to output the signals for pre-heater operation and supply fan monitor output with delay operation (for after heater), a setting change from PZ-62DR-E is necessary.

■ Connection Diagram

Note

- Be careful that the external device cable that connects to the PZ-4GS-E do not touch the surface of the Lossnay unit control board. It could lead to erroneous operation.
- Tighten the terminal block screws with a torque of 0.5N·m or less to avoid damaging the circuit board.
- When connecting two cables to one location on the terminal block, use a crimped terminal to ensure they are connected. Do not connect three or more cables.
- Especially when using Pre-heater output signal or After-heater output signal, refer to Lossnay installation and instruction manual.

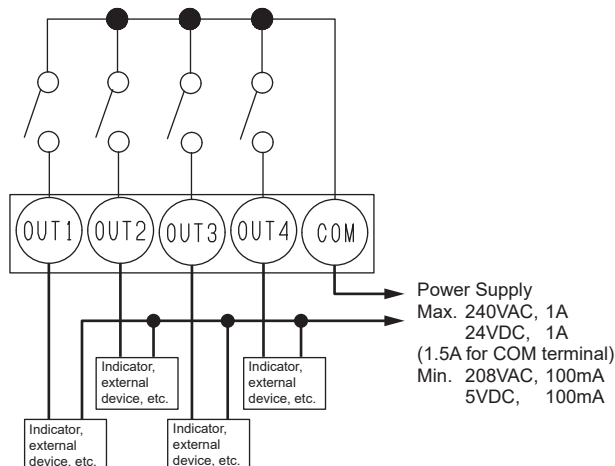

Crimped Terminal Connection Example

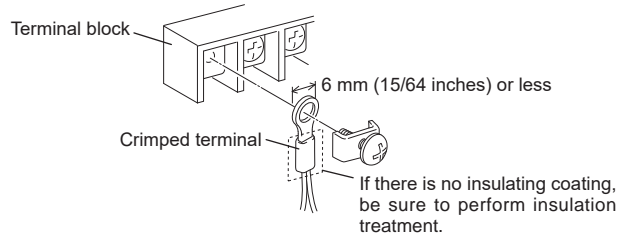

5. Function Settings

When PZ-62DR-E is used, the output signals from each terminal can be changed arbitrarily.
For how to change setting, please refer to the Lossnay installation and instruction manual.

6. Confirmation after Installation Work

After installation work is completed on the unit, follow the table below to perform inspection again. If there is a problem, be sure to fix it.

Before a trial operation, be sure to confirm the following items and check the checkboxes.

- Are the connection cables connected according to the connection diagram?
- Is the connection load capacity within the maximum and minimum range?
- Are the connection cables securely connected to the terminal block?
- Are the connection cables arranged so that they are not touching the surface of the Lossnay unit control board?
- Are any connectors on the circuit board disconnected?
- Are the function settings set correctly?

7. Trial Operation

Conduct a trial operation following the installation and instruction manual for the Lossnay unit.