

**MITSUBISHI ELECTRIC MULTI AIR CONDITIONERS OPTIONAL PARTS
PAC-KBU91MH-E**
Medium pressure sensor installation manual
(For applications with a vertical separation between indoor and outdoor units up to 60/90 m)
(1) Common items**

Certain restrictions (vertical separation between indoor and outdoor units, operable temperature range etc.) apply, depending on where the outdoor unit is installed. Models available for 60/90* meters of vertical separation between indoor and outdoor units are listed in appropriate manuals.

*Outdoor unit below indoor unit = 60 m (196 ft); Outdoor unit above indoor unit = 90 m (295 ft)

(2) Y series**

Certain restrictions (pipe diameter, maximum piping length etc.) apply, depending on where the outdoor unit is installed. Refer to the table below (DIP SW settings) for how to set the dipswitches on the outdoor unit.

(3) R2 series**

Certain restrictions (maximum total capacity of indoor units) apply, depending on where the outdoor unit is installed. Refer to the table below (DIP SW settings) for how to set the dipswitches on the outdoor unit.

Turn DIP SW 6-1 to ON on the G-, GA-, and HA-type BC controllers.

Use the BC controller (G/GA types) with the serial number 81W***** or later.





If the BC controller (G/GA types) has a serial number before 81W*****, replace the circuit board.

**Refer to appropriate manuals for details.

[DIP SW settings]

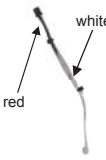
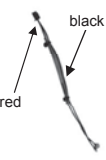
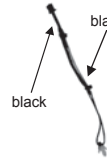
Model	Control box (Outdoor unit)	Control box (BC controller)
PUHY-(E)P***YHM-A(-BS)	2-3 ON	6-1 ON
PUHY-P***YHMU-A(-BS)		
PUHY-(E)P***YJM-A(-BS)		
PUHY-P***T(Y)JMU-A(-BS)		
PURY-(E)P***YHM-A(-BS)		
PURY-P***YHMU-A(-BS)		
PURY-(E)P***YJM-A(-BS)		
PURY-P***T(Y)JMU-A(-BS)		
PUHY-P***T(Y)KMU-A(-U)(-BS)	6-3 ON	6-1 ON
PUHY-EP***YKM-A(-BS)		
PUHY-P***Y(E)KC-A		
PUHY-P***YLKC-A		
PUHY-P***YRKC-A		
PUCY-P***YKA(-BS)(-T)		
PUHY-EP***YLM-A1(-BS)		
PUHY-P***YKB-A(1)(-BS)		
PUHY-P***T(Y)LMU-A(-BS)		
PUHY-P***T(Y)KA(-BS)		
PUHY-P***YPKC-A		
PUHY-P***ZKMU-A(-BS)		
PURY-P***T(Y)KMU-A(-U)(-BS)		
PURY-EP***YKM-A(-BS)		
PURY-P***YLM-A(1)(-BS)		
PURY-P***ZKMU-A(-BS)		

The following parts are included in the kit. Please check.

No.	①	②	③	④	⑤	⑥	⑦
External appearance							
Parts name	Medium pressure sensor assembly	Function setting connector	Function setting connector	Function setting connector	Label	Band	Pipe cover
Qty.	1	1	1	1	1	2	1

List of necessary parts for different models

No.	Parts	Model group															
		A	B	C	D	E	F	G	H	J	K	L	M	N	P	Q	
①	Medium pressure sensor assembly	○	○	○	○	○	○	○	○	○	○	○	○	○	○	○	
②	Function setting connector (wire color: red x white)	○	○	○	○	-	-	-	-	-	-	-	-	-	-	-	
③	Function setting connector (wire color: red x black)	-	-	-	-	○	○	○	-	-	-	-	-	-	-	-	
④	Function setting connector (wire color: black x black)	-	-	-	-	-	-	-	○	○	○	○	○	-	-	-	
⑤	Label	○	○	○	○	○	○	○	○	○	○	○	○	○	○	○	
⑥	Band (for control box guard (refer to Figure 4) and Pipe cover)	○	○	○	○	○	○	○	○	○	○	○	-	-	-	-	
⑦	Pipe cover (buffer)	-	-	-	-	-	-	-	-	-	-	-	-	-	-	-	

*Refer to Item (6) under "Installation Procedures" on page 2 for how to install item ⑦.

*Note that which mounting plate and function setting connector is used depends on the model. Refer to the table below (Model group list) for the detailed information on Model groups.

If the wrong type of function setting connector is connected, the unit will not properly operate or it will come to an abnormal stop.

[Models group list]

Group A	Group B	Group C	Group D
Model	Model	Model	Model
PUHY-P200/250YHM-A	PUHY-P300YHM-A	PUHY-P350/400/450YHM-A	PURY-P250/300/350/400YHM-A
PUHY-P72/96T(Y)HMU-A		PUHY-P120T(Y)HMU-A	PURY-P96/120T(Y)HMU-A
		PURY-P200YHM-A	
		PURY-P72T(Y)HMU-A	

Group E	Group F	Group G	Group H
Model	Model	Model	Model
PUHY-EP200YHM-A	PUHY-EP250/300YHM-A	PURY-EP250/300YHM-A	PUHY-P200/250YJM-A
	PURY-EP200YHM-A		PUHY-EP200YJM-A
			PUHY-P72/96T(Y)JMU-A

Group J	Group K	Group L	Group M
Model	Model	Model	Model
PUHY-P300YJM-A	PUHY-P350/400/450YJM-A	PURY-P250/300/350/400/450YJM-A	PUHY-P72/96T(Y)KMU-A
PUHY-P120/144T(Y)JMU-A	PUHY-EP250/300YJM-A	PURY-EP250/300/350YJM-A	PUHY-EP200/250YKM-A
	PURY-P200YJM-A	PURY-P96/120/144T(Y)JMU-A	PUHY-P200/250/300YKC-A
	PURY-EP200YJM-A		PUHY-P200/250/300YLKC-A
	PURY-P72T(Y)JMU-A		PUHY-P300/350YRKC-A
			PUCY-P200/250/300YKA
			PUHY-P200/250YKB-A(1)
			PUHY-P72/96T(Y)LMU-A
			PUHY-EP200/250/300/350YLM-A1
			PUHY-P200/250/300T(Y)KA
			PUHY-P200/250/300YPKC-A
			PUHY-P72/96ZKMU-A

Group N	Group P	Group Q
Model	Model	Model
PUHY-P120/144T(Y)KMU-A	PURY-P72/96/120/144T(Y)KMU-A	PUHY-P350/400/450YKC-A
PUHY-EP300/350/400/450YKM-A	PURY-EP200/250/300/350/400/450YKM-A	PUHY-P350/400/450YEKC-A
PUHY-P120/144/168T(Y)LMU-A	PURY-P200/250/300/350/400/450/500YLM-A(1)	PUHY-P350/400/450YLKC-A
PUHY-EP400/450/500YLM-A1	PURY-P72/96/120/144ZKMU-A	PUHY-P400/450YRKC-A
PUHY-P120/144ZKMU-A		PUCY-P350/400/450/500YKA
		PUHY-P300/350/400/450/500YKB-A(1)
		PUHY-P350/400/450/500T(Y)KA
		PUHY-P350/400/450/500YPKC-A

[Installation Procedures]

Install the sensor according to the procedures below.

(1) Turn off the power of the unit, and remove the top panel, bottom panel, and control box cover.

*If the earth wire is connected as shown in the left figure at right (Before), change it to the position as shown in the right figure at right (After).

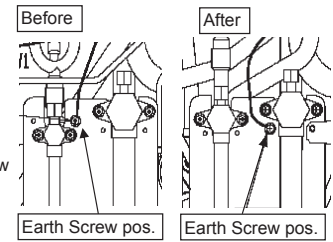

(2) Remove the lid of the service port on the service valve (liquid side for Y series or high-pressure side for R2 series), and install the medium pressure sensor assembly ① as shown in Figure 1.

(Tighten the nut at the service port to a torque of $38\pm 4\text{N}\cdot\text{m}$.)

Apply some sealing material (ThreeBond 1110D, field-supplied) to the service port screws to keep water out of the screw part.

Screw down the mounting plate of the medium pressure sensor with the fixing screw on the right side of the refrigerant service valve, which can be found either on the liquid side (Y series) or on the high-pressure side (R2 series).

*At the completion of installation, check for a refrigerant gas leak.

*On the units in Groups B, J, and N, loosen the screw on the mounting plate (refer to Figure 1 TOP VIEW), slide the mounting plate in the direction of the arrow in the figure until the screw comes in contact with the top end of the oval hole on the mounting plate, and then retighten the screw.

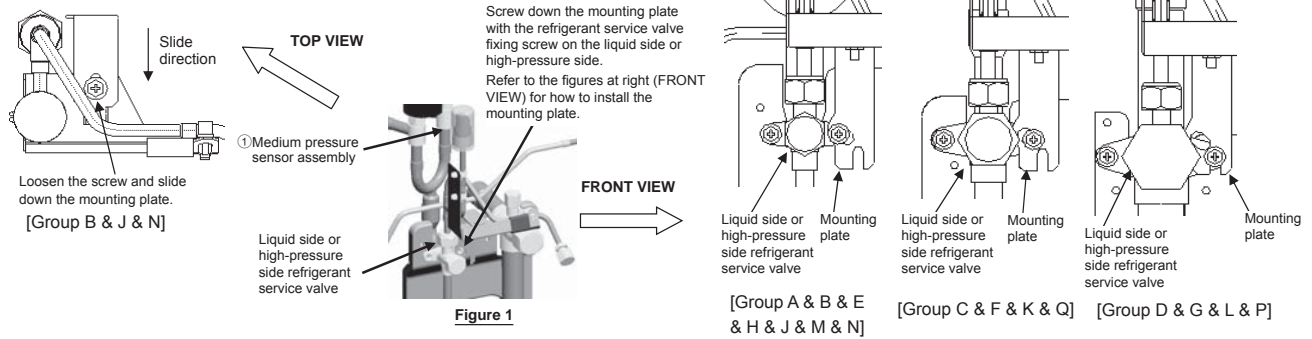

(3) Refer to Figure 2 for how to route the pressure sensor cable. Connect the pressure sensor connector to CN992 on the circuit board in the control box.

Fix the cables in place with the cable strap behind the frame at the bottom of the control box, just as with the cables of the sensors on the unit.

*Watch for static electricity when connecting connectors. (Static electricity can damage them.)

*Check that 63HS2 can be monitored from the Maintenance Tool.

(4) a. [Group A ~ G]

Remove the function setting connector that is connected to CNTYP4 on the Main board in the control box.

(Figure 2)

Insert the strap on the function setting connector (enclosed part ② or ③) into the hole on the right side of the control box, and then connect the connector to CNTYP4.

Remove the existing function setting connector to prevent it from being misused.

(Cut the strap with a nipper if the strap does not come off.)

b. [Group H ~ L]

Insert the strap on the function setting connector (enclosed part ④) into the hole on the right side of the control box, and then connect the connector to CNTYP1.

c. [Group M ~ Q]

No function setting connectors will be connected.

(5) Attach the label (enclosed part ⑤), which has the cautionary notes on replacing the circuit board, to the control box cover. (Figure 3)

(6) Wrap the pipe on the unit with the pipe cover (enclosed part ⑦) and fix it in place with a band (enclosed part ⑥) to protect it from coming in contact with the unit as necessary (refer to the figure at right).

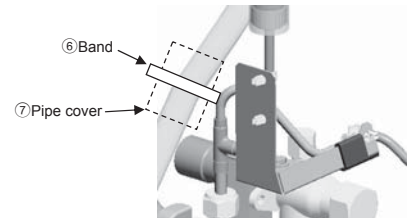

(7) Replace the top panel, bottom panel, and the control box cover.

Fix the cable in place with the cable strap behind the frame, and pull it out through the notched hole to the front as shown in the circled part below. Connect the cable to the connector on the Main board in the control box.
 *Keep the cable out of contact with the pipes.

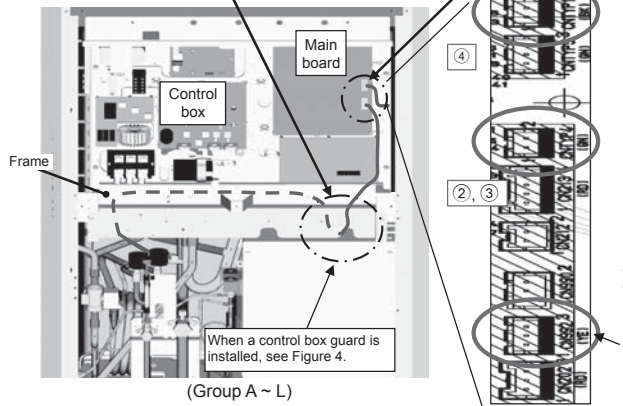
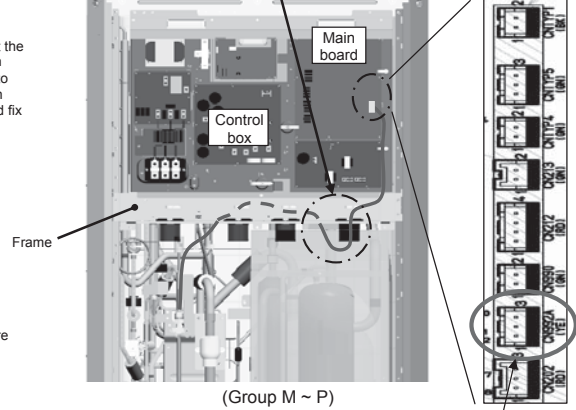

Figure 2

Clamp down the cable with the band in the back of the frame, push the cable through the rubber bush from the bottom, and connect the cable to the connector on the Main board in the control box.
 *Keep the cable out of contact with the pipes.



(Group M ~ P)

⑤ Label
 Place the label above the label on the control box cover so that the right side of both labels will form a straight line.

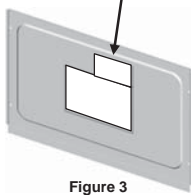

Figure 3

When a control box guard (sold separately) is used (Group A-L)
 Route the cable through the notched hole on the frame, push it through the rubber bush as shown in the figure below, and connect it to the Main board inside the control box. Then, hold the rubber bush in place with the band (enclosed part ⑤).

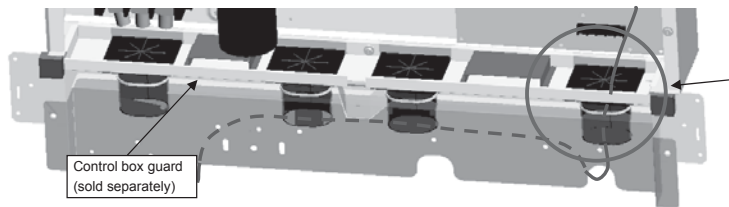
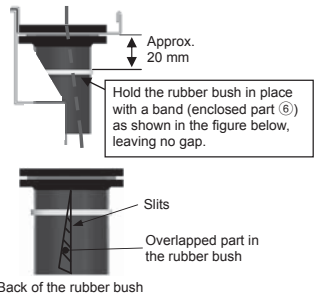

Figure 4



Connect the pressure sensor connector.

Hold the rubber bush in place with a band (enclosed part ⑤) as shown in the figure below, leaving no gap.

Slits
 Overlapped part in the rubber bush

Back of the rubber bush