

# **Procon**

# **MelcoBEMS MINI (A1M)**

---

FOR INSTALLERS

## **INSTALLATION MANUAL**

**Manual version 1.1.14**

**Firmware version 3.0.28 – For Revision 2, 3 & 4 variants only**

**Firmware version 3.1.05 – For Revision 5 variant only**

For safe and correct use, please read this installation manual thoroughly before installing the PROCON MelcoBEMS MINI (A1M).

# Preface

---

## Safety warnings

### ⚠ Caution:

Do not expose to rain or moisture.

### ⚠ Operating Temperature:

The product has been designed to operate between -20° C and +60° C

### ⚠ Shielded Signal Cables:

Use only shielded cables for connecting peripherals to any Procon MelcoBEMS MINI (A1M) device to reduce the possibility of interference with radio communications services. Using shielded cables ensures that you maintain the appropriate EMC classification for the intended environment.

### ⚠ CE Notice:

This product has been determined to be in compliance with 2014/30/EU (EMC Directive), 2014/35/EU (Low Voltage Directive) and 2011/65/EU (RoHS Directive).

UL 61010-1 Electrically Safety Tested.

### ⚠ UKCA Notice:

This product has been determined to be in compliance with SI 2016 No. 1091 (Electromagnetic Compatibility Regulations 2016), SI 2016 No. 1101, (Electrical Equipment (Safety) Regulations 2016) and SI 2012 No. 3032 (The Restriction of the Use of Certain Hazardous Substances in Electrical and Electronic Equipment Regulations 2012).

### ⚠ Class A:

Class A products are intended for use in non-residential/non-domestic environments. Class A products may also be utilized in residential/domestic environments but may cause interference and require the user to take adequate corrective measures.

This is a Class A product. In a domestic environment this product may cause radio frequency interference in which case the user may be required to take adequate measures.

A “Declaration of Conformity” in accordance with the preceding directives and standards has been created.

If this equipment does cause interference with radio communications services, which can be determined by turning the equipment off and on, you are encouraged to try to correct the interference by one or more of the following measures:

- Reorient the receiving antenna.
- Relocate the Procon MelcoBEMS MINI (A1M) with respect to the receiver.
- Move the Procon MelcoBEMS MINI (A1M) away from the receiver.

If necessary, consult a Procon MelcoBEMS MINI (A1M) technical support representative or an experienced radio/television or EMC technician for additional suggestions.

## **Disclaimer**

### **⚠ Warranty:**

All products manufactured on behalf of Mitsubishi Electric UK are warranted against defective materials for a period of three years from the date of delivery to the original purchaser.

### **⚠ Warning:**

Mitsubishi Electric UK assumes no liability for damages consequent to the user of this product. We reserve the right to change this manual at any time without notice. The information furnished by us is believed to be accurate and reliable. However, no responsibility is assumed by us for its use, nor for any infringements of patents or other rights of third parties resulting from its use.

If the equipment is used in a manor not specified by the manufacturer, the protection provided by the equipment may be impaired.

## Amendment Register

---

Document Version	Latest Firmware Version	Date	Author	Notes
1.0.0	3.0.0	08/05/15	GD	Initial version for firmware V1.0.0
1.0.1	3.0.1	16/06/15	GD	Added 'Applicable Unit Type' columns to Air-To-Water Modbus tables. Other minor modifications.
1.0.2	3.0.1	20/08/15	GD	More FTC5 model types added to 'Appendix B - Compatible Air-To-Water units'.
1.0.3	3.0.1	20/08/15	GD	FTC5 controller type PAC-IF062B-E added to 'Appendix B - Compatible Air-To-Water units'.
1.0.4	3.0.6	19/01/16	GD	Added ATW Modbus registers for measured energy consumed and measured energy produced.
1.0.5	3.0.11	15/06/16	GD	Changes to BACnet section.
1.0.6	3.0.11	23/08/16	GD	Minor changes.
1.0.7	3.0.12	01/08/16	GD	Added Flow Rate Modbus registers for ATW units.
1.0.8	3.0.12	21/10/16	SC / GD	Added warning paragraph on page iii. Added MET lab logo.
1.0.9	3.0.12	14/11/16	GD	Updated MET lab logo.
1.0.10	3.0.12	24/04/17	GD	Updated Appendix A – Compatible Air-To-Air units
1.0.11	3.0.13	19/06/17	GD	Latest firmware version updated to 3.0.13
1.0.12	3.0.13	31/07/17	GD	Added information to Installation section regarding connections to twin/triple/quad and MXZ systems. Correction made to section 2, the name MAC-399IF replaced with MAC-333IF.

1.0.13	3.0.13	25/08/17	GD	Modbus tables updated for QAHV units. QAHV-N560YA-HPB added to the compatible units list.
1.0.14	3.0.13	01/11/17	GD	Modbus tables updated for EAHV units. Numerous changes to Modbus tables due to updated protocol documentation.
1.0.15	3.0.15	08/11/17	GD	Added new Modbus tables for Lossnay units (firmware version must be 3.0.15 or later). Added firmware revision history table. Updated image in Figure 1. Modbus tables now have row headings at the top of every page. Added text to section 1. Overview
1.0.16	3.0.15	13/02/18	GD	Updated Modbus tables and Lossnay unit compatibility list. VL series Lossnay unit are not supported.
1.0.17	3.0.15	20/04/18	GD	Fixed errors in Modbus tables so <i>Applicable Unit Type</i> columns are correct for 'Defrost' and 'Brine Temperature' registers. EACV added to EAHV column names in Modbus tables. Added Appendix D – Compatible E-Series Chiller units.
1.0.18	3.0.15	22/05/18	GD	Added additional units to <i>Appendix A – Compatible Air-to-Air Units</i>
1.0.19	3.0.15	12/07/18	GD	Corrected the scaling of the Wh energy values in Modbus registers 40283 – 40299 and 30157 – 30173.
1.0.20	3.0.18	22/08/18	GD	Latest firmware version is now 3.0.18.
1.1.0	3.0.18	21/01/18	GD	Modbus tables for ATW units removed and placed in new separate document. Added Figures 3 and 4 showing connections to EAHV/EACV units. Added additional model types to Appendix D – Compatible E-Series Chiller units.
1.1.1	3.0.19	01/05/19	GD	Latest firmware version is now 3.0.19.
1.1.2	3.0.23	10/08/20	NB	Firmware version updated to 3.0.23.
1.1.3	3.0.25	16/12/20	NB / SC	Firmware version updated to 3.0.25. Added UKCA Notice + UKCA Logo URL updated. More units added to compatibility list in Appendix A
1.1.4	3.0.25	19/01/21	SC	Added Ecodan FTC6 units to Appendix B – Compatible Air-to-Water Units

1.1.5	3.0.25	02/12/21	SC	Added VL Vertical Series to Appendix C – Compatible Lossnay Units + updated all relevant Modbus tables
1.1.6	3.0.25	27/01/23	SC	Added Technical Specification required for CB report
1.1.7	3.0.28	20/12/21	JNF	BACnet HEAT_COOL set point feature enable ATA FAN speed allow input value 0x01
1.1.8	3.1.1	11/04/23	IB	New R5 hardware and firmware. Firmware branches from Version 3.0.25. Version 3.1.1 is NOT compatible with previous hardware.
1.1.9	3.1.1	12/07/23	SC	Added comment and diagram to section 6. <b>RS-485 termination</b> for R5 version
1.1.10	3.1.1	12/09/23	SC	Added 'Revision 2' reference to front page. Removed 'power cycle' comment from page 29.
1.1.11	3.1.01	14/03/24	SC	Added additional E-SERIES and CAHV models to Appendix section.
1.1.12	3.1.03	22/05/24	JNF	External Temperature Feedback feature added (ATA only)
1.1.13	3.1.04	01/04/25	JNF	Fixed the LED AC ACK not blinking when connecting to ATW and Lossnay
1.1.13	3.1.05	04/09/25	JNF	Set temperature A is available such that temperature value range from 16-31.5 increased 0 to 40 Heat pump run time count by A1M
1.1.14	3.1.05	04/09/25	JNF	Appendix B updated
1.1.14	3.1.05	12/02/26	JNF/SC	Figures 5 & 6 added Added additional safety page in French-Canadian Migrated Modbus Register Tables to separate Modbus Register Table Document V1.0 Appendix B - changed Ecodan title from FTC6 to FTC6 & FTC7 Appendix D - added new models

Any additional notes since printing will be appended to the rear of this document on separate sheets of paper.

## Firmware revision history

---

Firmware Version	Date	Notes
3.0.0	23/02/15	- Initial version of firmware with BACnet support for ATA protocol.
3.0.1	12/06/15	- Fixed bug so the 'Outdoor Temperature By BMS' Modbus register reports the correct value.
3.0.2	19/08/15	- DegF to DegC temperature conversions changed to be more accurate. - Removed BACnet objects for Heating and Cooling Setpoints. - BACnet PRESENT_VALUE property now writable for Analog Inputs if they are currently out of service. - Added range checking to BACnet Multi State Output object types when writing to the PRESENT_VALUE property.
3.0.3	06/10/15	- Removed the Min/Max Present Value properties for the Setpoint BACnet object.
3.0.4	29/10/15	- Minor changes to allow support for BACnet protocol revision 12.
3.0.5		- Version not released
3.0.6	15/01/16	- Added support for ATW energy monitoring commands
3.0.7	19/01/16	- Minor changes to aid BTL certification testing.
3.0.8	21/04/16	- Fixed minor bugs reported during BTL testing.
3.0.9	16/05/16	- Fixed more minor bugs reported during BTL testing.
3.0.10	19/05/16	- BACnet Device Object OBJECT_NAME property now writable.
3.0.11	19/05/16	- Fixed minor bug reported during BTL testing.
3.0.12	27/07/16	- Added support to read Flow Rate value for ATW units, value exposed as a Modbus register. - Fixed bug so Modbus writes are always actioned correctly. - This firmware version passed BTL testing.
3.0.13	03/04/17	- Change so writable (not commandable) Analog Value BACnet objects accept and action PRESENT_VALUE write commands for every priority value. The priority array is not updated though and all values remain NULL.
3.0.14	26/09/17	- Communication with connected unit is now reinitialised after if there has been no successful comms for a period of 1 minute.
3.0.15	09/11/17	- Added Modbus support for Lossnay units. - Fixed bug so Modbus comms counter Modbus register increments correctly.
3.0.16	09/03/18	- Fixed bug so writes to Modbus register 40027 are performed correctly for values greater than 7.
3.0.17	22/03/18	- Fixed bug so the fault code Modbus registers do not show value 6999 until there has been a comms error for at least 30 seconds.
3.0.18	10/08/18	- Fixed bug so ATA Setpoint Offset feature works correctly. - Introduced a failsafe reset to the MelcoBEMS MINI resets if there has been a CN105 comms fault for a period of two minutes.
3.0.19	01/05/19	- Fixed bug in Setpoint Offset feature so indoor unit setpoint value is set correctly when the BMS Virtual Setpoint Modbus register value is set to 26°C or greater.
3.0.23	10/08/20	-BACnet code changes to support protocol rev. 14
3.0.25	30/11/20	-Modbus registers added to support FTC6 controller.

3.0.28	20/12/21	- BACnet HEAT_COOL set point feature enable - ATA FAN speed allow input value 0x01
3.1.1	11/04/23	- No change to functionality. Firmware developed for new ST based hardware.
3.1.03	22/05/24	- Fixed bug of Lossnay temperature set point reading - Read Multiple on BACnet MSTP - Could feedback the External temperature sensor value to A/C by register [40432] - External temperature Polling feature implement
3.1.04	01/04/25	- Fixed the LED AC ACK not blinking when connecting to ATW and Lossnay
3.1.05	04/09/25	- Set temperature A is available such that temperature value range from 16-31.5 increased 0 to 40 - Heat pump run time count by A1M

**[Figure 1] MelcoBEMS MINI (A1M)**

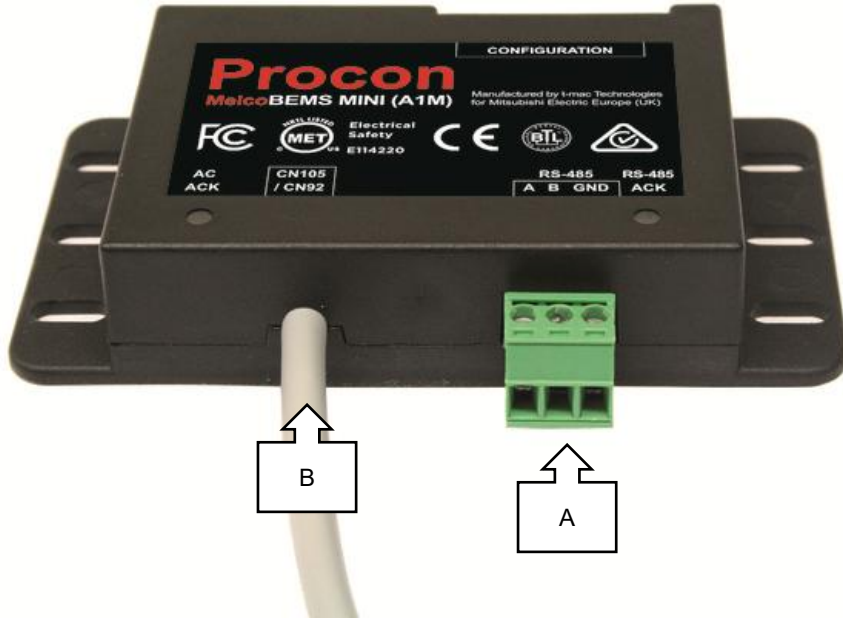

A RS485 connector  
B CN105/CN92 connection lead

[Figure 2]

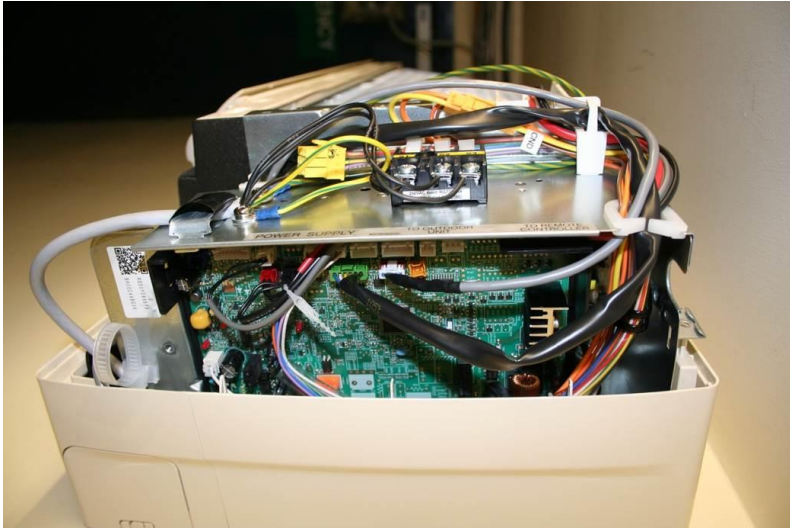

Air to air unit



Air to water unit

**[Figure 3] Air-Cooled Chilling Unit (EAHV/EACV-P900YA)**

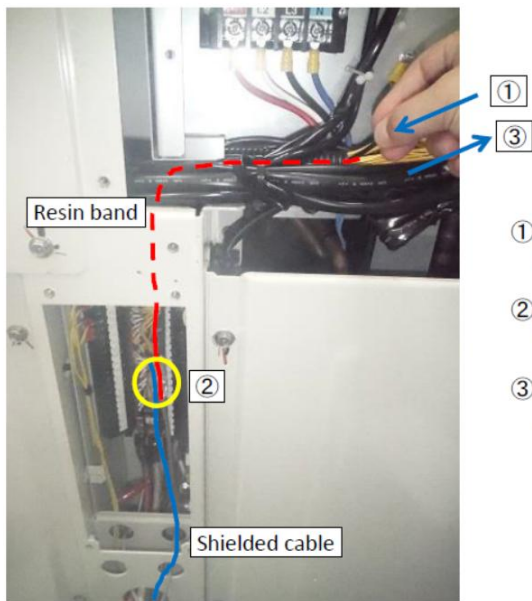
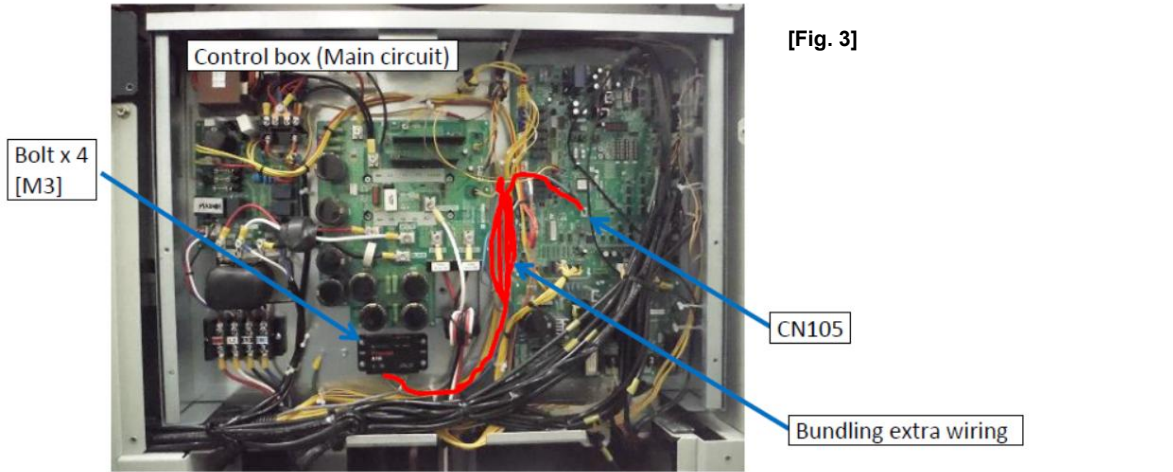

- ① Insert a resin band, etc. in the direction of the arrow in the wiring duct (near side).
- ② Fix the resin band and shielded cable for communication with tape.
- ③ Lead the shielded cable in the duct by pulling the resin band.



**[Figure 4] Air-Cooled Chilling Unit (EAHV/EACV-P1500, 1800YB)**

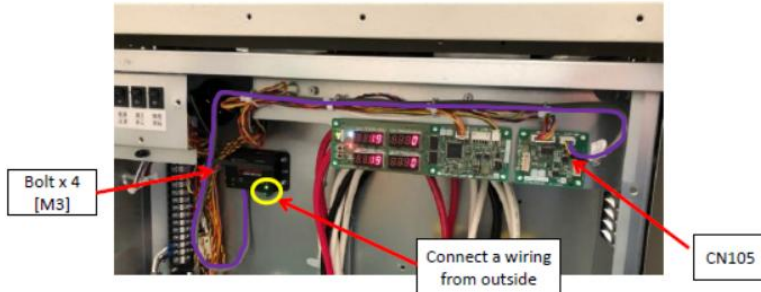

**Compressor information acquisition method(EAHV/EACV-P1500,1800YB)**

Compressor frequency and compressor ON/OFF information can be monitored for up to 16 units. Available information can be switched by Dip switch 2-10(BMS group setting) according to purpose.

① Information acquisition of representative unit in the system simultaneous operation group

(DIP SW2-10: OFF, only system leader)

The representative unit information in the simultaneous operation group can be acquired by connecting AIM to the representative unit.

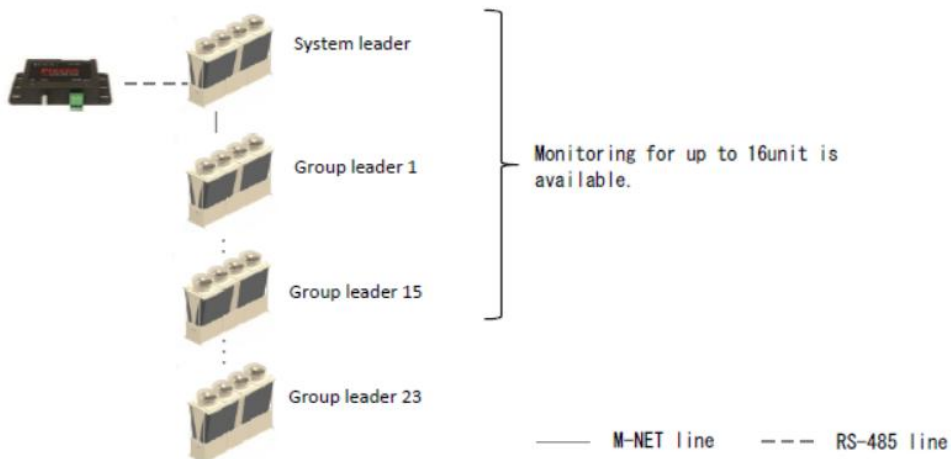

② Information acquisition for slave unit in the simultaneous operation group(DIP SW2-10:ON, only system leader)

The sub unit information of simultaneous operation group can be acquired by connecting AIM to system leader unit/group leader unit in the simultaneous operation group. It is required to connect AIM to each leader unit.

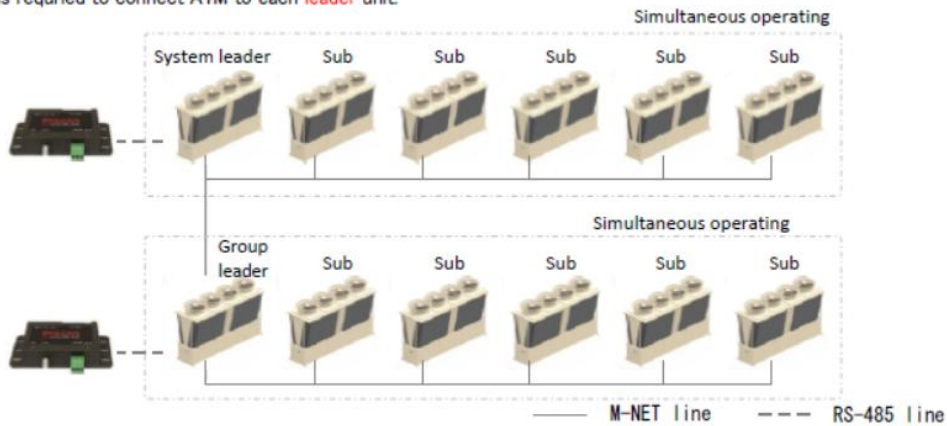

**[Figure 5] Air-Cooled Chilling Unit (EAHV/EACV-M1500,1800YCL)**

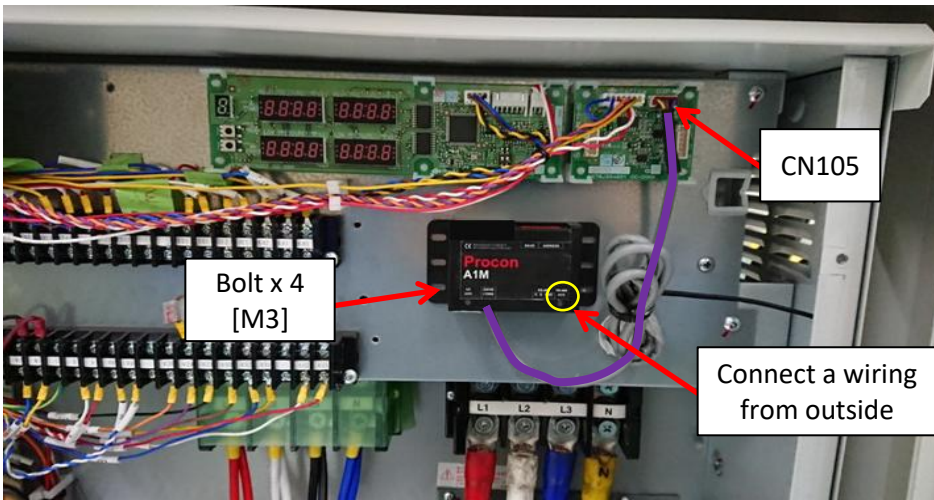

**Compressor information acquisition method(EAHV/EACV-M1500,1800YCL)**

Compressor frequency and compressor ON/OFF information can be monitored for up to 16 units.  
 Available information can be switched by Dip switch 5-10(BMS group setting) according to purpose.

**① Information acquisition of representative unit in the system simultaneous operation group (DIP SW5-10 : OFF, only system leader)**

The representative unit information in the simultaneous operation group can be acquired by connecting A1M to the representative unit.

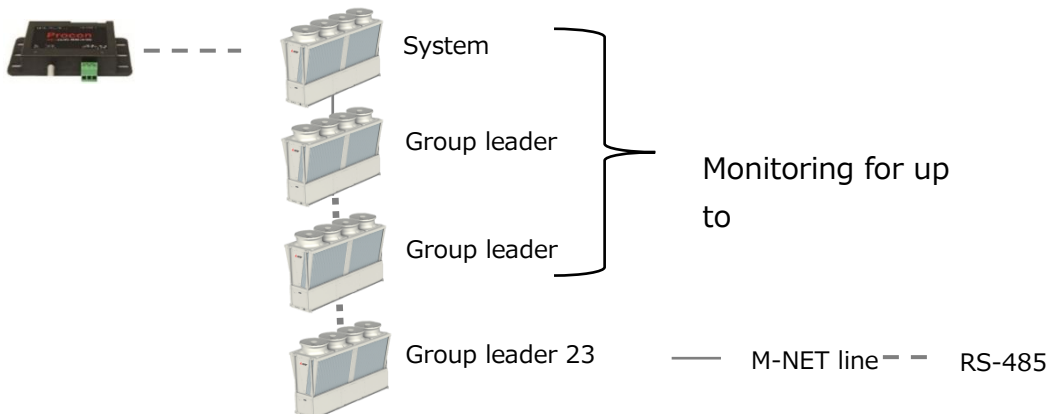

② **Information acquisition for slave unit in the simultaneous operation group  
(DIP SW5-10:ON, only system leader)**

The sub unit information of simultaneous operation group can be acquired by connecting A1M to system leader unit/group leader unit in the simultaneous operating group. It is required to connect A1M to each leader unit.

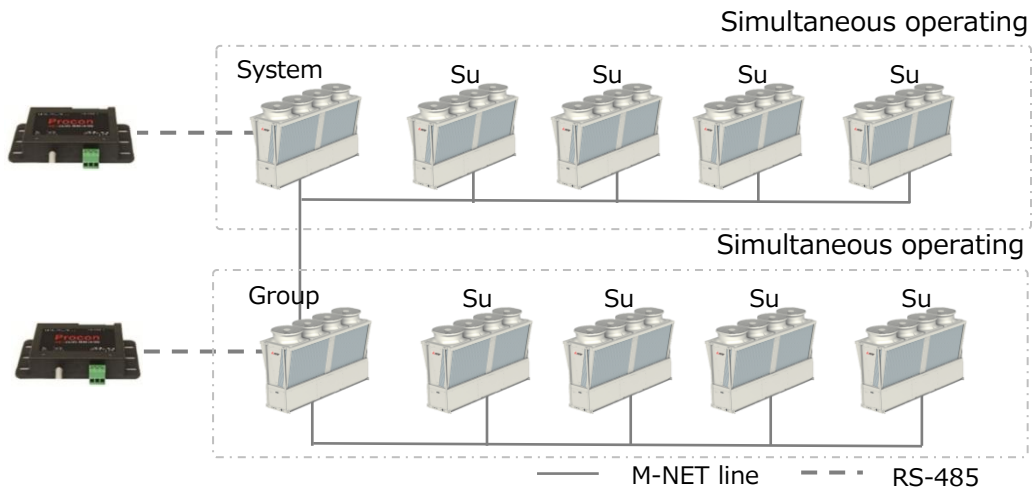

**[Figure 6] Water-Cooled Chilling Unit (ERCV-M900YA)**

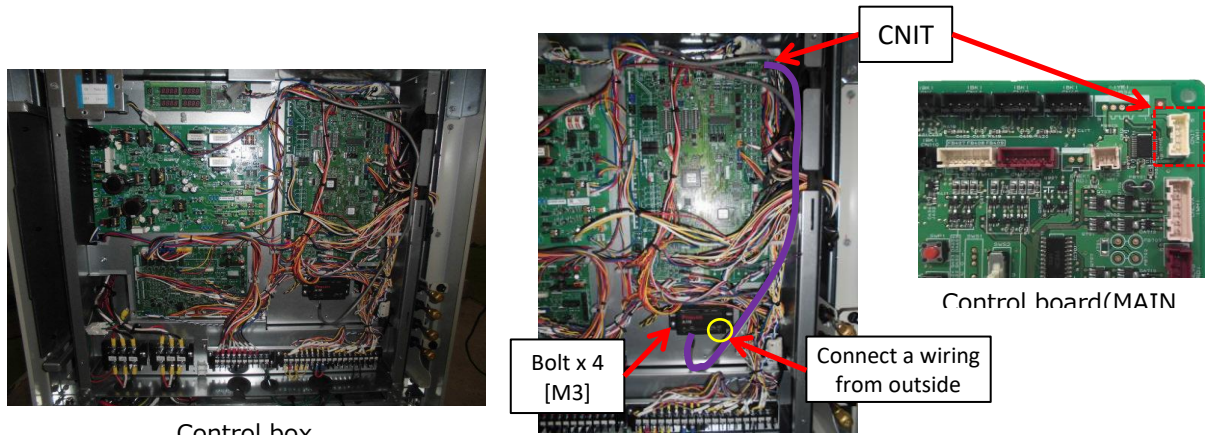

\*In case of Double stack style(ERCV-M900YA×2), install A1M on the MAIN

**Compressor information acquisition method(ERCV-M900YA)**

Compressor frequency and compressor ON/OFF information can be monitored for up to 16 units. Available information can be switched by Dip switch 5-10(BMS group setting) according to purpose.

**① Information acquisition of representative unit in the system simultaneous operation group (DIP SW5-10 : OFF, only system leader)**

The representative unit information in the simultaneous operation group can be acquired by connecting A1M to the representative unit.

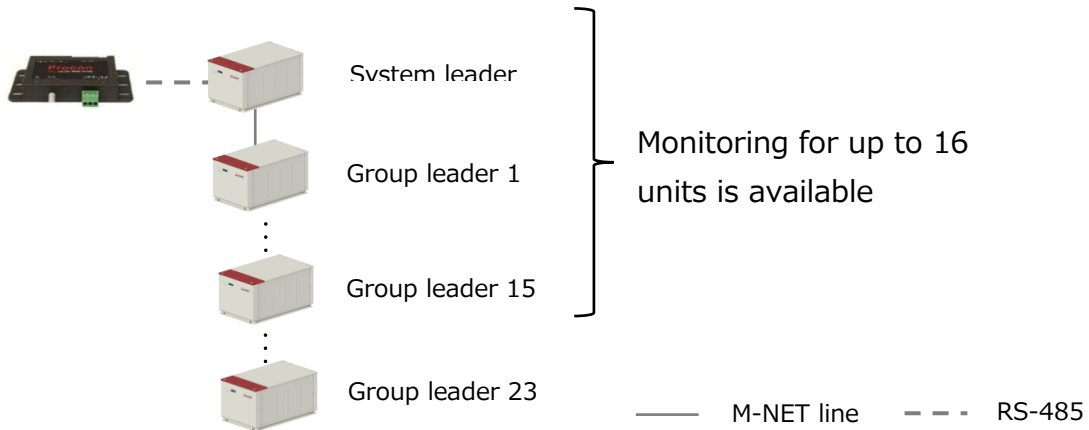

② **Information acquisition for alave unit in the simultaneous operation group  
(DIP SW5-10:ON, only system leader)**

The sub unit information of simultaneous operation group can be acquired by connecting A1M to system leader unit/group leader unit in the simultaneous operzation group. It is required to connect A1M to each leader unit.

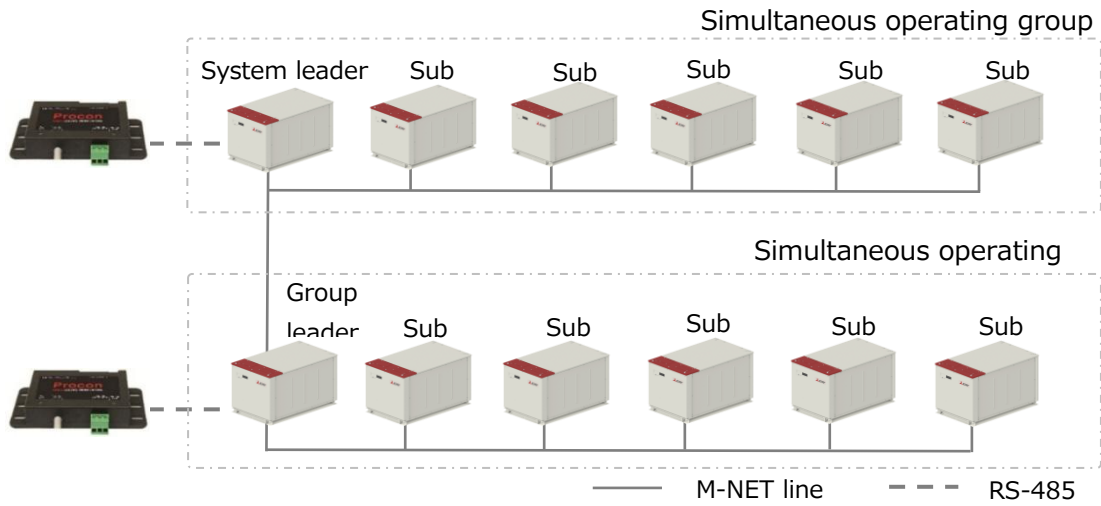

# Contents

<b>Preface</b> .....	<b>ii</b>
Safety warnings .....	ii
Disclaimer .....	iii
<b>Amendment Register</b> .....	<b>iv</b>
<b>Firmware revision history</b> .....	<b>vii</b>
<b>Contents</b> .....	<b>xvii</b>
<b>Safety precautions - EN</b> .....	<b>xviii</b>
<b>Mesures de sécurité - FR</b> .....	<b>xix</b>
<b>1. Overview</b> .....	<b>20</b>
<b>2. DIP switch settings</b> .....	<b>21</b>
2.1. RS-485 Node address .....	21
2.2. RS-485 communication settings .....	21
2.3. Protocol selection .....	22
2.4. Deadband mode .....	22
<b>3. Deadband Mode</b> .....	<b>23</b>
3.1. Settings .....	23
3.2. Operation .....	23
3.3. Initialisation .....	24
<b>4. Setpoint Offset</b> .....	<b>25</b>
4.1. Settings .....	25
4.2. Operation .....	25
<b>5. RS-485 termination</b> .....	<b>26</b>
<b>6. Installation</b> .....	<b>27</b>
6.1. Physical connection .....	27
6.2. Power supply .....	27
6.3. Modbus connections .....	27
6.4. Unit type selection .....	27
6.5. Using Twin/Triple/Quad systems .....	28
6.5.1. When fault Modbus register is being used .....	28
6.5.2. When fault Modbus register is not being used .....	28
6.6. Using single split units in a group .....	29
6.6.1. When fault Modbus register is being used .....	29
6.6.2. When fault Modbus register is not being used .....	29
6.7. Using MXZ split units .....	30
<b>7. Status LEDs</b> .....	<b>31</b>
7.1. AC ACK .....	31
7.2. RS-485 ACK .....	31
<b>8. BACnet</b> .....	<b>32</b>
8.1. BACnet MS/TP .....	32
8.2. BTL Listing .....	32
8.3. Object types supported .....	33
8.4. Object list .....	34
<b>9. Modbus connection</b> .....	<b>35</b>
9.1. Modbus background .....	35
9.2. Modbus registers .....	35
9.3. Modbus connections .....	36
<b>10. Modbus tables – Air-To-Air systems</b> .....	<b>37</b>
10.1. Holding registers .....	37
10.2. Input registers .....	40
10.3. Discrete Inputs .....	40
10.4. Coils .....	40
<b>11. Modbus tables – Air-To-Water systems</b> .....	<b>41</b>
<b>12. Modbus tables – Lossnay systems</b> .....	<b>42</b>
12.1. Holding registers .....	42
12.2. Input registers .....	46
12.3. Coils .....	48
12.4. Discrete Inputs .....	48
<b>13. Technical specification</b> .....	<b>50</b>
<b>Appendix A – Compatible Air-To-Air units</b> .....	<b>51</b>
<b>Appendix B – Compatible Air-To-Water units</b> .....	<b>54</b>
<b>Appendix C – Compatible Lossnay units</b> .....	<b>57</b>
<b>Appendix D – Compatible E-Series Chiller units</b> .....	<b>57</b>

## Safety precautions - EN

---

- **Before installing the unit, make sure you read all the “Safety precautions”**
- **The “Safety precautions” provide very important points regarding safety. Make sure you follow them**

### Symbols used in the text

#### **Warning:**

Describes precautions that should be observed to prevent danger of injury or death to the user.

#### **Caution:**

Describes precautions that should be observed to prevent damage to the unit.

#### **Warning:**

- **Ask the dealer or an authorised technician to install the unit**
  - Improper installation by the user may result in electric shock, or fire
- **Use the specified cables for wiring. Make the connections securely so that any outside forces acting on the cables are not applied to the terminals**
  - Inadequate connection and fastening may generate heat and cause a fire
- **Never repair the unit. If the controller must be repaired, consult the dealer**
  - If the unit is repaired improperly, electric shock, or fire may result
- **Have all electric work done by a licensed electrician according to "Electric Facility Engineering Standard", "Interior Wire Regulations" and the instructions given in this manual and always use a special circuit**
  - If the power source capacity is inadequate or electric work is performed improperly, electric shock and fire may result
- **Keep the electric parts away from any water - washing water etc...**
  - Contact may result in electric shock, fire or smoke
- **To dispose of this product, consult your dealer**

#### **Caution:**

- **Safely dispose of the packing materials**
  - Packing materials, such as nails and other metal or wooden parts, may cause stabs or other injuries
  - Tear apart and throw away plastic packaging bags so that children will not play with them - If children play with a plastic bag which has not been torn apart, they face the risk of suffocation

## Mesures de sécurité - FR

---

- **Veillez à lire les mesures de sécurité avant d'installer l'unité.**
- **Les mesures de sécurité fournissent les éléments importants concernant la sécurité. Veillez à les suivre.**

### Symboles dans le texte

#### Prudence :

Indique les mesures à prendre pour prémunir l'utilisateur contre le danger de blessure ou de décès.

#### Avertissement :

Indique les mesures à prendre pour éviter les dommages à l'unité.

#### Prudence :

- **Demander au concessionnaire ou à un technicien certifié d'installer l'unité.**
  - Une installation incorrecte par l'utilisateur pourrait causer une électrocution ou un feu.
- **Utiliser les fils indiqués pour le câblage. Effectuer les connexions de manière sûre afin que les jonctions ne soient pas touchées par les éléments extérieurs exerçant une force sur les câbles.**
  - Une connexion et une fixation incorrectes peuvent créer de la chaleur et provoquer un incendie.
- **Ne jamais réparer soi-même l'unité. En cas de réparation nécessaire du contrôleur, s'informer auprès du concessionnaire.**
  - Une réparation incorrecte de l'unité pourrait causer une électrocution ou un feu.
- **Tous les travaux d'électricité doivent être effectués par un électricien certifié, conformément à la « norme d'ingénierie des installations électriques », au « règlement sur le filage intérieur » et aux instructions données dans ce manuel. Toujours utiliser un circuit spécial.**
  - Une capacité insuffisante de la source d'alimentation ou des travaux électriques incorrects entraînent un risque d'électrocution et d'incendie.
- **Tenir les éléments électriques à l'écart de l'eau (eau de lavage, etc.).**
  - Un contact avec l'eau pourrait causer une électrocution, un feu ou de la fumée.
- **S'informer auprès du concessionnaire pour se débarrasser du produit.**

#### Avertissement :

- **Se débarrasser des matériaux d'emballage de manière sûre.**
  - Les matériaux d'emballage tels que les clous et les autres composants en métal ou en bois peuvent provoquer des lésions ou d'autres blessures.
  - Déchirer et jeter les sacs d'emballage en plastique afin qu'aucun enfant ne puisse jouer avec cet emballage et ne risque de s'étouffer avec un sac.

# 1. Overview

---

The Procon MelcoBEMS MINI (A1M) Protocol Converter is used for remote monitoring and control of both Air-to-Air products (M-, S- and P-series split air conditioning systems) and Air-to-Water products (CAHV, CRHV, PWFY). It acts as a gateway between the system and external third party equipment.

The MelcoBEMS MINI (A1M) continuously reads data from the system and changes configuration when necessary. Because the reading is continuous the MelcoBEMS MINI (A1M) always stores up-to-date data. This data is then available to external devices through the RS-485 port using the Modbus RTU software protocol. Values can be read and changed via this connection. Please refer to the Modbus section for further information.

The MelcoBEMS MINI (A1M) is powered via the CN105/CN92 connector, hence no external power supply is needed.

Compatible model numbers can be found in the appendices of this document.

## **⚠ Caution:**

MAC-397IF and MAC-333IF units cannot be connected when the MelcoBEMS MINI (A1M) is connected, as the same CN105/CN92 connector is used.

Appendix A lists the compatible Air-To-Air indoor units.  
Appendix B lists the compatible Air-To-Water indoor units.  
Appendix C lists the compatible Lossnay units.

**Figure 1** shows the MelcoBEMS MINI (A1M) converter.

**Figure 2** shows the CN105/CN92 connector on the indoor unit PCB that the MelcoBEMS MINI (A1M) connects to, for both Air-to-Air and Air-To-Water type units.

**[ATA – Modbus RTU and BACnet MS/TP Available](#)**

**[ATW Ecodan Heating Products – Only Modbus RTU Available](#)**

**[E Series Chillers – Only Modbus RTU Available](#)**

**[Lossnay – Only Modbus RTU Available](#)**

## 2. DIP switch settings

---

There is a bank of 8 DIP switches on the MelcoBEMS MINI (A1M) labeled 'CONFIGURATION'. These switches are used to configure communication settings and to enable some features.

### 2.1. RS-485 Node address

When BACnet MS/TP protocol has been selected (see section 0) the node address is used as the Station ID.  
When Modbus RTU protocol has been selected (see section 0) The node address is used as the Slave ID.

Any node address in the range 1 – 30 can be chosen using switches 1 – 5. The address is set in binary, where the switch positions have the following values:

Switch number	Value when switch is set to ON
1	1
2	2
3	4
4	8
5	16

To get the node address, add together the value for each switch set ON. For example, to set address 13, set switches 1, 3 and 4 ON (1 + 4 + 8 = address 13).

When all switches 1 – 5 are set to the ON position the node address is set in software by writing to a Modbus register (see Modbus Holding Registers section).

Note: When all switches are set to the OFF position a node address of 1 is assumed.

Note: Each MelcoBEMS MINI (A1M) connected on the same RS-485 network must be set to a unique node address.

### 2.2. RS-485 communication settings

The RS-485 settings are set using DIP switch 6.

When the switch is in the OFF position the Baud Rate and Parity settings are set in software by writing to Modbus registers (see Modbus Holding Register section).

Switch 6	RS-485 communication settings
OFF	Baud Rate and Parity set in software
ON	9600 baud, no parity

The number of data bits is fixed at 8 and the number of stop bits is fixed at 1.

### **2.3. Protocol selection**

The RS485 protocol is set using DIP switch 7.

When the switch is in the ON position the Modbus RTU protocol is selected.

<b>Switch 7</b>	<b>Protocol selection</b>
OFF	BACnet MS/TP
ON	Modbus RTU

### **2.4. Deadband mode**

The Deadband feature can be enabled using DIP switch 8.

When the switch is in the OFF position the Deadband feature is disabled.

When the switch is in the ON position the Deadband feature is enabled.

<b>Switch 8</b>	<b>Deadband feature</b>
OFF	Disabled
ON	Enabled

### 3. Deadband Mode

---

The deadband mode is enabled by setting DIP switch 8 ON. It is only applicable to Air-To-Air type units.

#### 3.1. Settings

There are two settings, the Heating Setpoint (default 19°) and Cooling Setpoint (default 23°C). These values can be changed via Modbus, refer to the Air-To-Air Modbus tables for more information.

The Cooling Setpoint must be at least 2°C greater than the Heating Setpoint, otherwise the default values given above will be assumed.

#### 3.2. Operation

When enabled, the MelcoBEMS MINI (A1M) controls the Mode and Temperature Setpoint based on the Room (return air) Temperature.

While the room temperature is less than the *Heating Setpoint* the unit will be set to HEAT mode with a setpoint of 28°C. Whilst in HEAT mode, if the room temperature rises above the *Heating Setpoint* + 1°C the unit will be set to FAN mode.

Whilst in FAN mode, if the temperature rises above the *Cooling Setpoint* the unit will be set to COOL mode with a setpoint of 19°C. Whilst in COOL mode, if the room temperature falls below the *Cooling Setpoint* – 1°C the unit will be set to FAN mode.

Whilst in FAN mode, if the room temperature falls below the *Heating Setpoint* the unit will be set to HEAT mode with a setpoint of 28°C.

The following image shows this graphically (assuming a Heating Setpoint of 19°C and a Cooling Setpoint of 23°C):

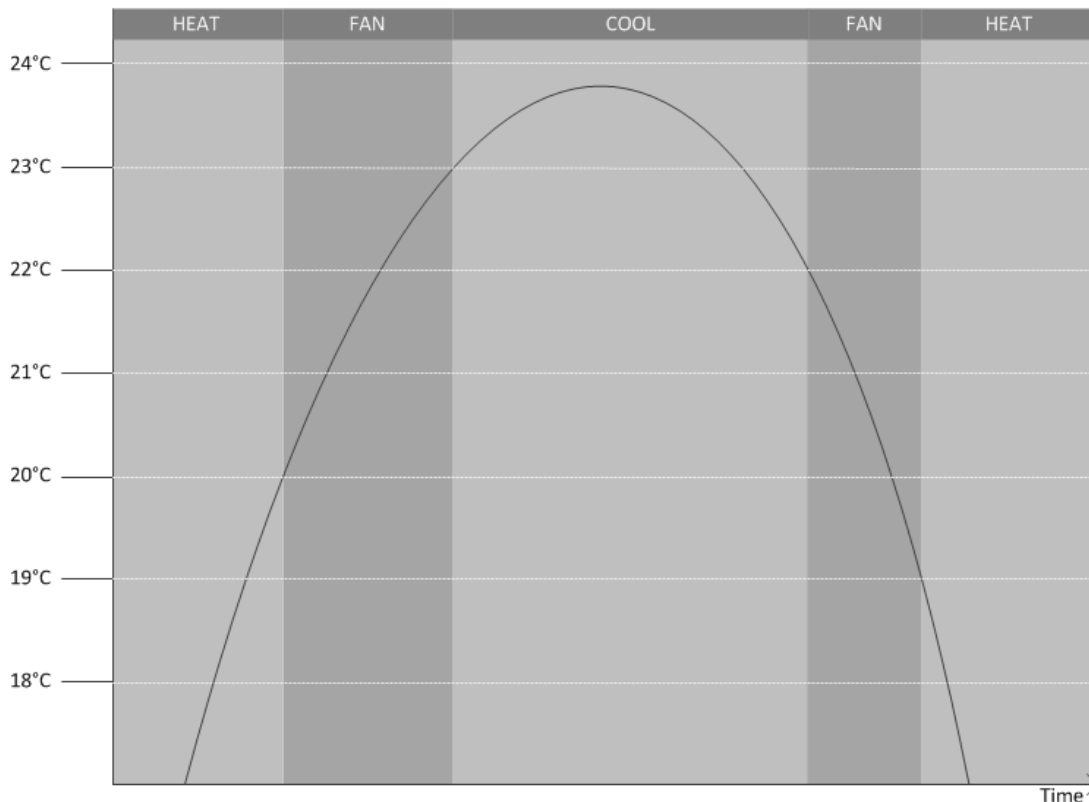

### **3.3. Initialisation**

When the MelcoBEMS MINI (A1M) powers up it will set the mode, which will be determined by the room temperature.

If less than the Heating Setpoint the unit will be set to HEAT mode with a setpoint of 28°C.

If greater than or equal to the Cooling Setpoint the unit will be set to COOL mode with a setpoint of 19°C.

If between the Heating and Cooling Setpoints the unit will be set to FAN mode.

## 4. Setpoint Offset

---

The Setpoint Offset feature is only applicable to, and will only be enabled for, Air-To-Air type units.

### 4.1. Settings

There are two settings which are applicable to the Setpoint Offset feature, *BMS Room Temperature* and *BMS Virtual Setpoint*.

The BMS Virtual Setpoint can be changed using Modbus and is stored in non-volatile memory so the value is retained if the MelcoBEMS MINI (A1M) loses power.

The BMS Room Temperature can be changed using Modbus but is not stored in non-volatile memory, so the value is lost and reset to zero upon the MelcoBEMS MINI (A1M) losing power.

### 4.2. Operation

In some situations a 3<sup>rd</sup> party room temperature sensor connected to a BMS or other controller may provide a more accurate temperature reading than the return air temperature of the indoor unit. The A1M can calculate the difference between these two temperature readings and compensate by adjusting the indoor unit's temperature setpoint.

The new temperature setpoint is calculated using the following equation:

$$\text{Temperature Setpoint} = \text{Return Air Temperature} - (\text{BMS Room Temperature} - \text{BMS Virtual Temperature})$$

As a hypothetical example, consider the BMS Virtual Setpoint being set to 21°C and the indoor unit return air temperature remaining constant at 22°C. As the BMS Room Temperature decreases the MelcoBEMS MINI (A1M) increases the indoor unit's temperature setpoint.

When the BMS Room Temperature reaches 18°C the Temperature Setpoint =  $22 - (18 - 21) = 25^\circ\text{C}$ .

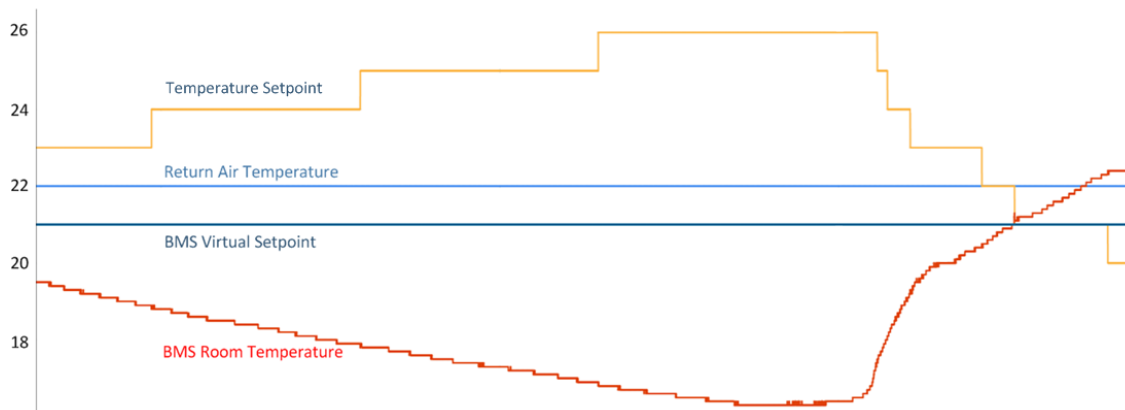

Hysteresis has been built in to prevent the temperature setpoint from rapidly changing.

The setpoint offset will only operate correctly if the BMS Room Temperature is periodically updated via Modbus, to ensure the MelcoBEMS MINI (A1M) always has an up to date reading.

If the BMS Room Temperature is set to 0°C (which it will be on power up) the setpoint offset feature will be disabled. It will only activate when the BMS Room Temperature is not 0°C.

To disable the feature without removing the MelcoBEMS MINI (A1M) power, simply set the BMS Room Temperature to 0°C.

## 5. RS-485 termination

---

An RS-485 termination resistor can be enabled on the MelcoBEMS MINI (A1M) PCB using the single jumper labeled J1.

The jumper setting is summarised below:

Jumper Setting	Description
Not fitted	Termination resistor not enabled
Fitted	Termination resistor enabled

**Note:** The J1 jumper is only available on Revision 3 & 4 variants. For Revision 5 variant, the 120Ω termination resistors for the RS-485 network must be supplied by the installing contractor and fitted across pins A & B on the first & last device.

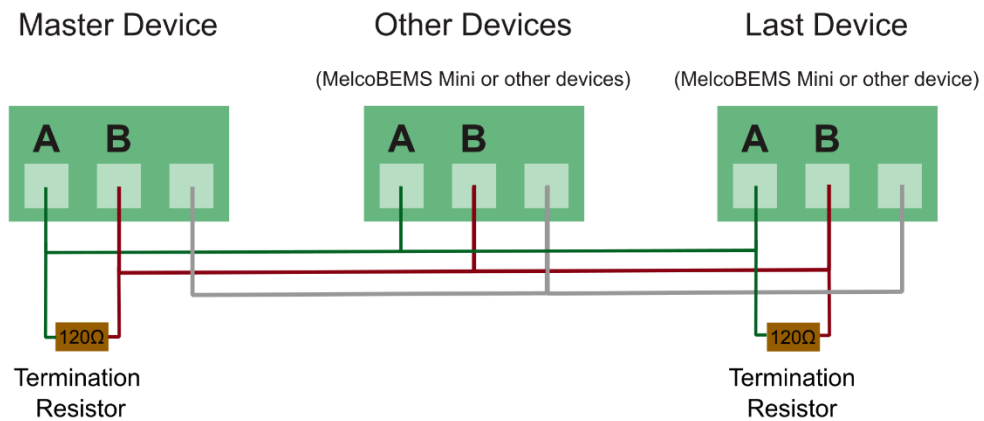

## 6. Installation

---

### **6.1. Physical connection**

The MelcoBEMS MINI (A1M) has a 1 metre flying lead to connect directly into the CN105/CN92 connector on the controller PCB. As an example, Figure 2 shows this connection on a Mr Slim indoor unit and a CRHV unit.

### **6.2. Power supply**

The MelcoBEMS MINI (A1M) is powered from the CN105/CN92 air conditioner host connector at 12V DC and therefore does not require an external power supply.

### **6.3. Modbus connections**

The MelcoBEMS MINI (A1M) has a 3-way screw terminal to provide Modbus RTU communication via RS-485. Figure 1 shows the RS-485 connections. The Modbus section contains further detail of the Modbus communications.

### **6.4. Unit type selection**

The MelcoBEMS MINI (A1M) software will automatically detect whether an Air-To-Air or Air-To-Water unit is connected. It will then only send commands applicable to that unit type.

## 6.5. Using Twin/Triple/Quad systems

It is recommended to use one MelcoBEMS MINI for each indoor unit, however, if the fault Modbus register is not used then one MelcoBEMS MINI can be used per twin / triple / quad system.

### 6.5.1. When fault Modbus register is being used



### 6.5.2. When fault Modbus register is not being used



## 6.6. Using single split units in a group

It is recommended to use one MelcoBEMS MINI for each indoor unit, however, if the fault Modbus register is not used then one MelcoBEMS MINI can be used per system.

### 6.6.1. When fault Modbus register is being used



### 6.6.2. When fault Modbus register is not being used



### 6.7. Using MXZ split units

One MelcoBEMS MINI must be installed for each indoor unit when using a MXZ system.

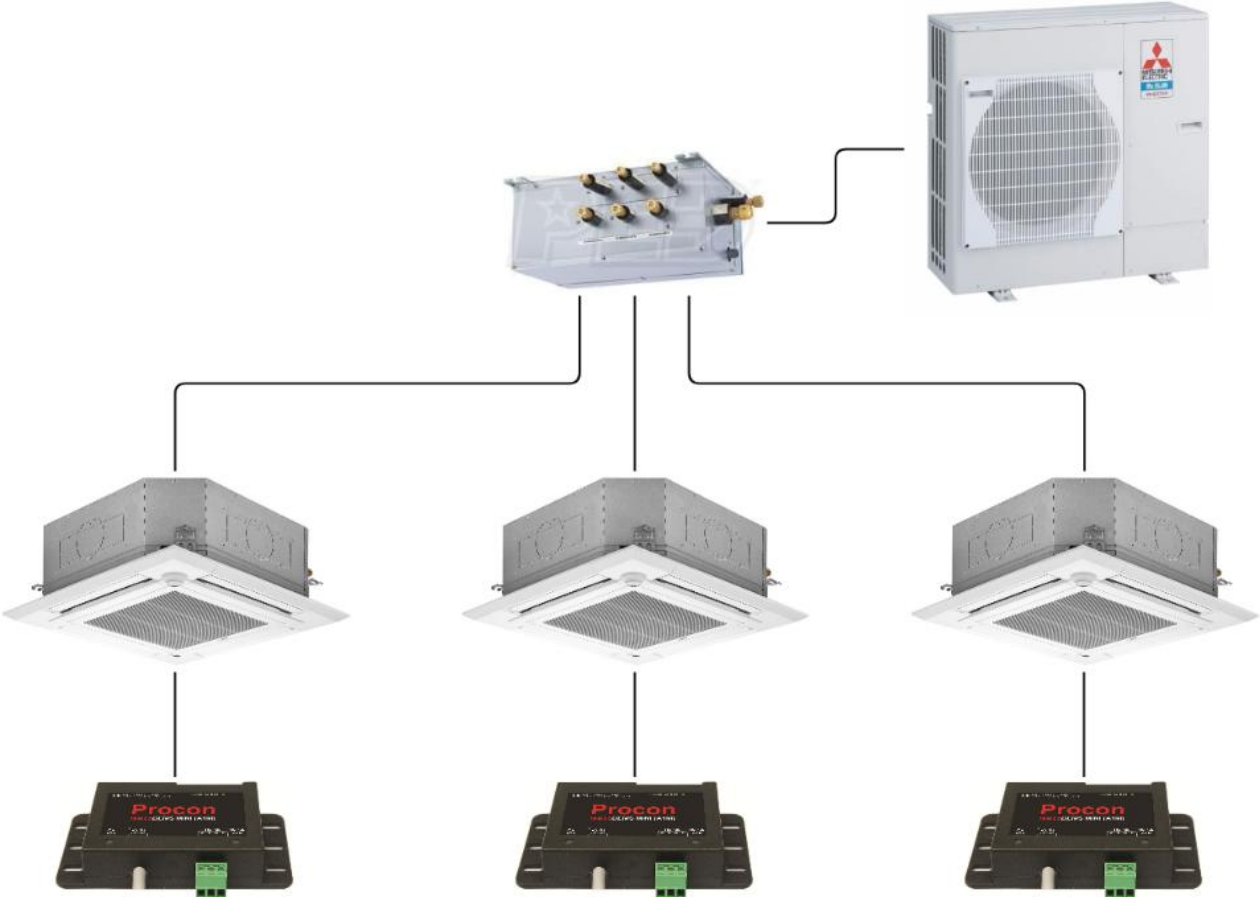

## 7. Status LEDs

---

There are two status LEDs on the MelcoBEMS MINI (A1M). The LED indications are as follows:

LED Name	Colour	Functionality
AC ACK	Green	Lit when A1M is powered, flashing indicates valid communication with the indoor unit.
RS-485 ACK	Green	Lit when A1M is powered, flashing indicates valid Modbus or BACnet communication.

### 7.1. AC ACK

If this LED is permanently lit and does not flash, check the CN105/CN92 connection is secure and the unit type is supported (see appendix).

### 7.2. RS-485 ACK

If this LED is permanently lit and does not flash it could be due to a physical RS-485 connection problem, or incorrect Modbus/BACnet/RS-485 configuration.

## 8. BACnet

---

### **8.1. BACnet MS/TP**

The MelcoBEMS MINI (A1M) can be connected to a BACnet MS/TP network using RS-485.

BACnet protocol can be selected using DIP switch 7 (see section 0).

### **8.2. BTL Listing**

The MelcoBEMs MINI (A1M) is a BTL listed device.

### 8.3. Object types supported

Property	Object Type						
	Device	Analogue Value	Binary Input	Binary Output	Multi State Input	Multi State Output	Analogue Input
Object Identifier	R	R	R	R	R	R	R
Object Name	R/W	R	R	R	R	R	R
Object Type	R	R	R	R	R	R	R
Present Value		R/W	R <sup>1</sup>	R/W	R <sup>1</sup>	R/W	R <sup>1</sup>
Status Flags		R	R	R	R	R	R
Event State		R	R	R	R	R	R
Out Of Service		R	R	R	R	R	R
Number Of States					R	R	
State Text					R	R	
Units		R					R
Polarity			R	R			
Priority Array		R		R		R	
Relinquish Default		R		R	R	R	
System Status	R						
Vendor Name	R						
Vendor Identifier	R						
Model Name	R						
Firmware Revision	R						
Application Software Version	R						
Location	R						
Description	R						
Protocol Version	R						
Protocol Revision	R						
Protocol Services Supported	R						
Protocol Object Types Supported	R						
Object List	R						
Max APDU Length Accepted	R						
Segmentation Supported	R						
APDU Timeout	R						
Number Of ADPU Retries	R						
Max Master	R						
Max Info Frames	R						
Device Address Binding	R						
Database Revision	R						

R = Read accessible only.

R<sup>1</sup> = Read accessible only but writable when the Out Of Service property is TRUE.

R/W = Read and write accessible.

## 8.4. Object list

The MelcoBEMS MINI (A1M) currently has objects for certain ATA protocol data points, detailed in the following table.

Object type	Object ID	Object name	Notes
Binary Output	BO0	Drive OFF/ON Setup	0 = Drive OFF 1 = Drive ON
Binary Input	BI1	Drive OFF/ON State	0 = Drive OFF 1 = Drive ON
Analog Value	AV2	Setpoint	Value in either °C or °F, depending on the Temperature Units setting
Multi-state Output	MSO3	Mode Setup	1 = Heating 2 = Humidity reduction 3 = Cooling 4 = Ventilation, clean air operation 5 = Auto Operation
Multi-state Input	MSI4	Mode State	1 = Heating 2 = Humidity reduction 3 = Cooling 4 = Ventilation, clean air operation 5 = Auto Operation
Multi-state Output	MSO5	Fan Speed Setup	1 = Auto 2 = Quiet 3 = Weak 4 = Strong 5 = Very strong (SH i)
Multi-state Input	MSI6	Fan Speed State	1 = Auto 2 = Quiet 3 = Weak 4 = Strong 5 = Very strong (SH i)
Multi-state Output	MSO7	Air Direction Setup	1 = Auto 2 = Position 1 3 = Position 2 4 = Position 3 5 = Position 4 6 = Position 5 7 = Swing
Multi-state Input	MSI8	Air Direction State	1 = Auto 2 = Position 1 3 = Position 2 4 = Position 3 5 = Position 4 6 = Position 5 7 = Swing
Multi-state Output	MSO9*	Temperature Units	1 = °C 2 = °F
Analog Input	AI10	Inlet Temperature	Value in either °C or °F, depending on the Temperature Units setting
Analog Input	AI11	Fault Code	4-digit fault code
Binary Output	BO12	External Temperature ON/OFF Setup	0 = Feature OFF 1 = Feature ON This feature is feedback the [AV13] value to AC unit which could replace the internal temperature value
Analog Value	AV13	External Temperature Input	Value in either °C or °F, depending on the Temperature Units setting

## 9. Modbus connection

---

### 9.1. Modbus background

Modbus is a master-slave protocol, which means there are two types of Modbus device, Modbus *Masters* and Modbus *Slaves*.

Slave devices simply wait until they receive a command from a Master, act upon that command and send a reply to the Master. Slaves do not have the ability to send commands to other devices on the bus. Master devices are responsible for sending commands to slave devices and receiving data. Modbus only permits there to be one Master device on the bus at any one time, but up to 247 slaves can be connected at a time.

Modbus is most commonly used over RS-485, which is a hardware standard allowing multiple devices to be connected on the same bus.

Each Slave device must have a unique ID on the bus, which is referred to as a *Slave ID*. Each Modbus command the Master sends will contain this Slave ID and only the Slave with that Slave ID will reply.

### 9.2. Modbus registers

Modbus Slave devices store data in registers. There are four register types and each type has its own register bank. The register types are summarised below:

Register Name	Register Type	Description
Discrete Input	Digital Input	Read only register used for holding status information which holds a value of 0 or 1.
Coil	Digital Output	Read and write accessible register which holds a value of 0 or 1.
Input Register	Analogue Input	Read only register used for status information which holds a 16-bit value (0-65535)
Holding Register	Analogue Output	Read and write accessible register used for status information which holds a 16-bit value (0-65535)

### 9.3. Modbus connections

For communication over RS-485 all 3 connections are needed. These are labeled A, B and GND. Please refer to the connection diagrams below.

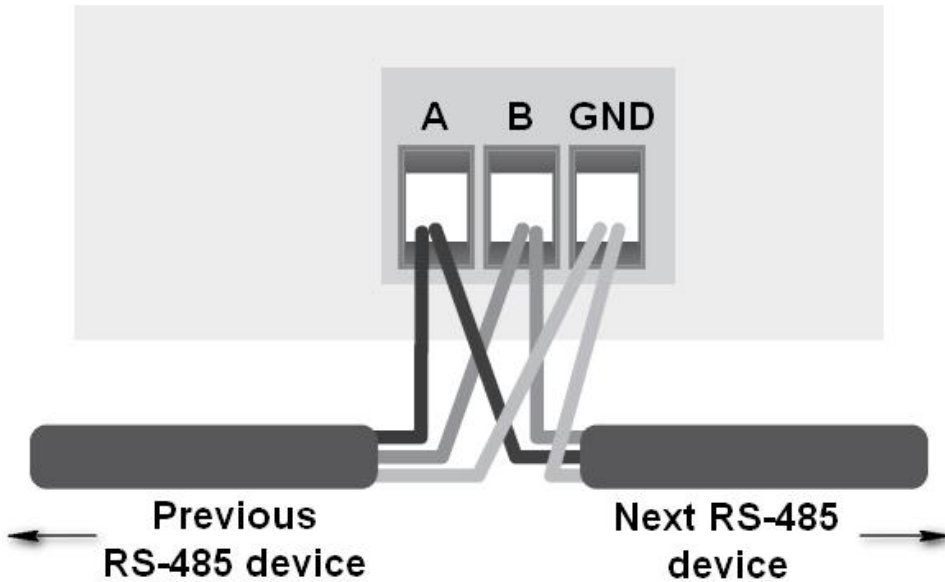

**⚠ Caution:**

The RS-485 cable must be a shielded data cable. Mains flex or other unshielded cable should not be used. The cable shield should be connected to GND at one end only.

**⚠ Caution:**

RS-485 has polarised data connections. It is crucial that all 'A's are connected together, all 'B's are connected together and all 'GND's are connected together.

**⚠ Caution:**

The RS-485 cable must be daisy-chained in a bus network. T-junctions (e.g. star network wiring) are not permitted.

**⚠ Caution:**

RS-485 biasing jumpers must be fitted on the Procon MelcoRETAIL/MelcoREMOTE (if used).

## 10. Modbus tables – Air-To-Air systems

Some BMS controllers can only read Modbus Holding Registers, so the MelcoBEMS MINI (A1M) also exposes all Discrete, Coil and Input Registers as Holding Registers. The Discrete Input registers and Input registers are not writable so their equivalent Holding Register is read only and marked **[READ ONLY]**.

Some BMS controllers may not be able to read signed register values (i.e. values which can be negative in value), so the MelcoBEMS MINI (A1M) also exposes an unsigned version of those registers (these registers will not return a negative value).

### 10.1. Holding registers

Holding Registers are read using function code 03 and written to using either function code 06 or 16. Function code 06 is used when writing to a single holding register, function code 16 is used for writing to multiple holding registers in the same command.

Holding Registers (Analogue Outputs)			
Register Name	Address	Modicon Address	Details
Drive Mode	0	40001	1 = Heating 2 = Humidity reduction 3 = Cooling 7 = Ventilation, clean air operation 8 = Auto Operation 9 = i-see heating operation* 10 = i-see humidity reduction* 11 = i-see cooling *  * indicates a read only value, writing this value will have no effect
Temperature Setpoint	1	40002	Temperature value in °C multiplied by 10. e.g. value 200 = 20°C
Fan Speed	2	40003	0 = Auto 2 = Quiet 3 = Weak 5 = Strong 6 = Very strong (SH i)
Air Direction	3	40004	0 = Auto 1 = Position 1 2 = Position 2 3 = Position 3 4 = Position 4 5 = Position 5 7 = Swing
Modbus Slave ID	4	40005	Values 1 – 247 valid
BACnet Station ID			Values 1 -127 valid

Holding Registers (Analogue Outputs)			
Register Name	Address	Modicon Address	Details
Modbus RS-485 Baud Rate	5	40006	0 = 9600 1 = 1200 2 = 2400 3 = 4800 4 = 9600 5 = 14400 6 = 19200 7 = 28800 8 = 38400 9 = 56000 10 = 57600 11 = 115200
BACnet RS-485 Baud Rate			0 = 9600 4 = 9600 6 = 19200 8 = 38400 10 = 57600
RS-485 Parity Type	6	40007	0 = None 1 = Even 2 = Odd
Drive On/Off	7	40008	0 = Drive OFF 1 = Drive ON
Room Temperature [READ ONLY]	8	40009	Temperature value in °C multiplied by 10. e.g. value 200 = 20°C
Fault Code (hex) [READ ONLY]	9	40010	0x8000 = No error 0x6999 = Bad communication with indoor unit (Refer to indoor unit documentation for description of other fault code values)
MelcoBEMS MINI (A1M) Firmware Version [READ ONLY]	10	40011	MelcoBEMS MINI (A1M) firmware version
Modbus Comms Counter [READ ONLY]	11	40012	Value of a counter which increments upon every valid Modbus command received. Value is automatically reset to zero when value exceeds 65535.
Fault Code (decimal) [READ ONLY]	12	40013	8000 = No error 6999 = Bad communication with indoor unit (Refer to indoor unit documentation for description of other fault code values)
System Type Detected [READ ONLY]	13	40014	0 = ATA 1 = ATW 2 = Lossnay 255 = Undetermined (no unit detected yet)
Deadband Enabled State [READ ONLY]	14	40015	0 = Deadband disabled (DIP switch 8 OFF) 1 = Deadband enabled (DIP switch 8 ON)
BMS Room Temperature (signed)	15	40016	Signed temperature value in °C multiplied by 10. 0xFF9C = -10°C ... 0x01F4 = 50°C
BMS Room Temperature	16	40017	Temperature value in °C multiplied by 10. 0 = 0°C ... 500 = 50°C
BMS Virtual Setpoint	17	40018	Temperature value in °C multiplied by 10. 100 = 10°C ... 400 = 40°C
Deadband Heating Setpoint	18	40019	Temperature in °C (default 19°C). Value must be at least 2°C lower than the Deadband Cooling Setpoint.
Deadband Cooling Setpoint	19	40020	Temperature in °C (default 23°C). Value must be at least 2°C higher than the Deadband Heating Setpoint.

Holding Registers (Analogue Outputs)			
Register Name	Address	Modicon Address	Details
BACnet Device Instance (most significant 16 bits)	272	40273	Most significant 16 bits of the 32-bit Device Instance
BACnet Device Instance (least significant 16 bits)	273	40274	Least significant 16 bits of the 32-bit Device Instance
BACnet Max Master	274	40275	Maximum number of masters to search for
BACnet Max Info Frames	275	40276	
BACnet APDU Timeout	276	40277	Timeout value in ms for client requests
BACnet APDU Retries	277	40278	Number of times to retry after timeout
External Temperature feedback function ON/OFF	430	40431	0 = Disable (Default) 1 = Enable A1M will feedback the [40432] to AC unit when write to [40432]
External Temperature feedback Value	431	40432	External Temperature feedback value in °C multiplied by 10. e.g. value 200 = 20°C
External Temperature Polling Feature	432	40433	0 = Disable 1 = Enable (Default) A1M will feedback the [40432] to AC unit for every 10 seconds

## 10.2. Input registers

Input Registers are read using function code 04.

Note the values of all Input registers have corresponding Holding registers which can be used instead.

Input Registers (Analogue Inputs)			
Register Name	Address	Modicon Address	Details
Room Temperature	0	30001	Temperature value in °C multiplied by 10. e.g. value 200 = 20°C
Fault Code (hex)	1	30002	0x8000 = No error 0x6999 = Bad communication with indoor unit (Refer to indoor unit documentation for description of other fault code values)
MelcoBEMS MINI (A1M) Firmware Version	3	30004	MelcoBEMS MINI (A1M) firmware version
Modbus Comms Counter	5	30006	Value of a counter which increments upon every valid Modbus command received. Counter is reset to zero when value exceeds 65535.
Fault Code (decimal)	8	30009	8000 = No error 6999 = Bad communication with indoor unit (Refer to indoor unit documentation for description of other fault code values)
System Type Detected	9	30010	0 = ATA 1 = ATW 2 = Lossnay 255 = Undetermined (no unit detected yet)
Deadband Enabled State	10	30011	0 = Deadband disabled (DIP switch 8 OFF) 1 = Deadband enabled (DIP switch 8 ON)

## 10.3. Discrete Inputs

There are no Discrete Inputs for Air-To-Air systems.

## 10.4. Coils

Coils are read using function code 01 and written to using either function code 05 or 15. Function code 05 is used when writing to a single coil register, function code 15 is used for writing to multiple coil registers in the same command.

Note the values of all Coil registers have corresponding Holding registers which can be used instead.

Coils (Digital Outputs)			
Register Name	Address	Modicon Address	Details
Drive On/Off  <i>(Note: Holding register address 7 can also be used to change the Drive)</i>	0	00001	0 = Drive OFF 1 = Drive ON

## 11. Modbus tables – Air-To-Water systems

---

The Modbus register tables for ATW systems has been moved to a separate document. Please download the latest version of "MelcoBEMS MINI (A1M+ A1M R5) - Modbus Register Tables" from Mitsubishi website.

## 12. Modbus tables – Lossnay systems

Some BMS controllers can only read Modbus Holding Registers, so the MelcoBEMS MINI (A1M) also exposes all Discrete, Coil and Input Registers as Holding Registers. The Discrete Input registers and Input registers are not writable so their equivalent Holding Register is read only and marked **[READ ONLY]**.

Some BMS controllers may not be able to read signed register values (i.e. values which can be negative in value), so the A1M also exposes an unsigned version of those registers (these registers will not return a negative value).

### 12.1. Holding registers

Holding Registers are read using function code 03 and written to using either function code 06 or 16. Function code 06 is used when writing to a single holding register, function code 16 is used for writing to multiple holding registers in the same command.

Holding Register (Analogue Output)				Applicable Unit Type	
Register Name	Addr	Modicon Address	Details	Lossnay LGH Series	Lossnay VL Series
Modbus Slave ID	4	40005	Values 1 – 247 valid	✓	✓
Modbus RS-485 Baud Rate	5	40006	0 = 9600 1 = 1200 2 = 2400 3 = 4800 4 = 9600 5 = 14400 6 = 19200 7 = 28800 8 = 38400 9 = 56000 10 = 57600 11 = 115200	✓	✓
RS-485 Parity Type	6	40007	0 = None 1 = Even 2 = Odd	✓	✓
Fault/Error Code (hex) <b>[READ ONLY]</b>	9	40010	0x8000 = No error 0x6999 = Bad communication with unit (Refer to indoor unit documentation for description of other fault code values)	✓	✓
MelcoBEMS MINI (A1M) Firmware Version <b>[READ ONLY]</b>	10	40011	MelcoBEMS MINI (A1M) Firmware Version	✓	✓
Modbus Comms Counter <b>[READ ONLY]</b>	11	40012	Value of a counter which increments upon every valid Modbus command received. Counter is reset to zero when value exceeds 65535.	✓	✓
System Type Detected <b>[READ ONLY]</b>	13	40014	0 = ATA unit connected 1 = ATW system connected 2 = Lossnay system connected 255 = Undetermined (no unit detected yet)	✓	✓
Power On/Off	300	40301	0 = Power OFF 1 = Power ON	✓	✓
Operating Mode	301	40302	1 = Heat 3 = Cool 7 = Fan 8 = Auto		
Ventilation Mode	302	40303	0 = Lossnay mode 1 = Bypass mode 2 = Auto mode	✓	✓

Holding Register (Analogue Output)				Applicable Unit Type	
Register Name	Addr	Modicon Address	Details	Lossnay LGH Series	Lossnay VL Series
Fan Speed A	303	40304	0 = Auto 1 = Speed 1 2 = Speed 2 3 = Speed 3 4 = Speed 4	✓#2	✓#2
Temperature Setpoint A	304	40305	Temperature value in °C multiplied by 10. 0 = 0°C ... 400 = 40°C  Note: Only available when 'Set Temperature on Temperature Control Unit' value = 1 or 2.		
Supply Air Temperature [READ ONLY]	305	40306	Temperature value in °C multiplied by 10. 0 = 0°C ... 400 = 40°C  Note: Only available when 'Supply Air Temperature Sensor' value = 1 (Equipped).		
Outdoor Temperature (signed) [READ ONLY]	306	40307	Temperature value in °C multiplied by 10. (see note *)  Note: Only available when 'Outdoor Temperature Sensor' value = 1 (Equipped).	✓	✓
Outdoor Temperature [READ ONLY]	307	40308	Temperature value in °C multiplied by 10. (see note **)  Note: Only available when 'Outdoor Temperature Sensor' value = 1 (Equipped).	✓	✓
Room Temperature A [READ ONLY]	308	40309	Temperature value in °C multiplied by 10. 0 = 0°C ... 400 = 40°C  Note: Only available when 'Return Air Temperature Sensor' value = 1 (Equipped).	✓	✓
Room CO2 Level [READ ONLY]	309	40310	CO2 level multiplied by 10. 0 = 0ppm ... 240 = 2400 and above. [Value 254 = Under detecting] [Value 255 = No sensor]  Note: Only available when 'CO2 Level Sensor' value = 1 (Equipped).		
Fault/Error Code (hex) [READ ONLY]	310	40311	0x8000 = No error 0x6999 = Bad communication with unit (Refer to Lossnay unit documentation for description of other fault code values)	✓	✓
Fault/Error Code (decimal) [READ ONLY]	311	40312	8000 = No error 6999 = Bad communication with unit (Refer to Lossnay unit documentation for description of other fault code values)	✓	✓
Thermo On/Off [READ ONLY]	312	40313	0 = Thermo OFF 1 = Thermo ON		
Energy Consumption [READ ONLY]	313	40314	Value in kWh multiplied by 10. 0 = 0kWh ... 65535 = 6553.5kWh	✓	✓
Actual Operation Mode [READ ONLY]	314	40315	0 = Not auto mode 1 = Determining 2 = Heating 3 = Cooling		
Auto Fan Speed Control Availability [READ ONLY]	315	40316	0 = Not available 1 = Available		
Night Purge [READ ONLY]	316	40317	0 = Normal operation 1 = In night purge operation  During night-purge operation: - Pressing ON/OFF button starts normal operation. - When pressing the Ventilation button the Lossnay remains in bypass mode	✓	✓

Holding Register (Analogue Output)				Applicable Unit Type	
Register Name	Addr	Modicon Address	Details	Lossnay LGH Series	Lossnay VL Series
Maintenance Sign [READ ONLY]	317	40318	0 = Inactive 1 = Active	✓	✓
Filter Sign [READ ONLY]	318	40319	0 = Inactive 1 = Active	✓	✓
Actual Ventilation Mode [READ ONLY]	319	40320	0 = Lossnay ventilation 1 = Bypass ventilation	✓	✓
Actual Supply Fan Speed [READ ONLY]	320	40321	0 = Stop 1 = Speed 1 2 = Speed 2 3 = Speed 3 4 = Speed 4	✓	✓
Actual Extract Fan Speed [READ ONLY]	321	40322	0 = Stop 1 = Speed 1 2 = Speed 2 3 = Speed 3 4 = Speed 4	✓	✓
Setpoint 0.5°C Increments Availability [READ ONLY]	322	40323	0 = Not available 1 = Available		
Heat/Cool or Cool-Only [READ ONLY]	323	40324	0 = Heat and Cool 1 = Cool only		
Auto Operation Mode Availability [READ ONLY]	324	40325	0 = Not available 1 = Available		
Heat/Cool or Heat-Only [READ ONLY]	325	40324	0 = Heat and Cool 1 = Heat only		
Minimum Cooling Setpoint [READ ONLY]	326	40327	Temperature value in °C multiplied by 10. 0 = 0°C ... 400 = 40°C  Note: Only available when 'Set Temperature on Temperature Control Unit' value = 1 or 2.		
Maximum Cooling Setpoint [READ ONLY]	327	40328	Temperature value in °C multiplied by 10. 0 = 0°C ... 400 = 40°C  Note: Only available when 'Set Temperature on Temperature Control Unit' value = 1 or 2.		
Minimum Heating Setpoint [READ ONLY]	328	40329	Temperature value in °C multiplied by 10. 0 = 0°C ... 400 = 40°C  Note: Only available when 'Set Temperature on Temperature Control Unit' value = 1 or 2.		
Maximum Heating Setpoint [READ ONLY]	329	40330	Temperature value in °C multiplied by 10. 0 = 0°C ... 400 = 40°C  Note: Only available when 'Set Temperature on Temperature Control Unit' value = 1 or 2.		
Minimum Auto Setpoint [READ ONLY]	330	40331	Temperature value in °C multiplied by 10. 0 = 0°C ... 400 = 40°C  Note: Only available when 'Set Temperature on Temperature Control Unit' value = 1 or 2.		
Maximum Auto Setpoint [READ ONLY]	331	40332	Temperature value in °C multiplied by 10. 0 = 0°C ... 400 = 40°C  Note: Only available when 'Set Temperature on Temperature Control Unit' value = 1 or 2.		
Energy Consumption Data Available [READ ONLY]	332	40333	0 = Not available 1 = Available	✓	✓
Number of Fan Speeds [READ ONLY]	333	40334	Values 1 – 4 valid.	✓	✓

Holding Register (Analogue Output)				Applicable Unit Type	
Register Name	Addr	Modicon Address	Details	Lossnay LGH Series	Lossnay VL Series
Bypass Damper Available [READ ONLY]	334	40335	0 = Not available 1 = Available	✓	✓
Auto Ventilation Mode Available [READ ONLY]	335	40336	0 = Not available 1 = Available	✓	✓
Operation Mode of Temperature Control Unit [READ ONLY]	336	40337	0 = Not available (not connected) 1 = Available (connected)		
Set Temperature on Temperature Control Unit [READ ONLY]	337	40338	0 = No set temperature display 1 = RA (Return Air) temperature 2 = SA (Supply Air) temperature		
Outdoor Temperature Sensor [READ ONLY]	338	40339	0 = Not equipped 1 = Equipped	✓	✓
Return Air Temperature Sensor [READ ONLY]	339	40340	0 = Not equipped 1 = Equipped	✓	✓
Supply Air Temperature Sensor [READ ONLY]	340	40341	0 = Not equipped 1 = Equipped		
CO2 Level Sensor [READ ONLY]	341	40342	0 = Not equipped 1 = Equipped		

\* Temperature in °C multiplied by 10.

0xFDD0 = -56.0°C  
0xFDD5 = -55.5 °C

...

0xFFFFB = -0.5°C  
0x0000 = 0.0°C  
0x0005 = 0.5 °C

...

0x0271 = 62.5°C  
0x0276 = 63.0°C

[0x7FFE = Under detecting]

[0x7FFF = No thermistor connected]

\*\* Temperature in °C multiplied by 10.

0x0000 = 0.0°C  
0x0005 = 5.0°C

...

0x0271 = 62.5°C  
0x0276 = 63.0°C

[0x7FFE = Under detecting]

[0x7FFF = No thermistor connected]

#1 Lossnay ventilation mode supported only, Bypass and Auto modes not supported.

#2 Auto fan speed (value 0) not supported.

## 12.2. Input registers

Input Registers are read using function code 04.

Input Register (Analogue Input)				Applicable Unit Type	
Register Name	Addr	Modicon Address	Details	Lossnay LGH Series	Lossnay VL Series
MelcoBEMS MINI Firmware Version	3	30004	MelcoBEMS MINI Firmware Version	✓	✓
Modbus Comms Counter	5	30006	Value of a counter which increments upon every valid Modbus command received. Value will automatically reset to zero when value exceeds 65535.	✓	✓
System Type Detected	9	30010	0 = ATA unit connected 1 = ATW system connected 2 = Lossnay system connected 255 = Undetermined (no unit detected yet)	✓	✓
Supply Air Temperature	174	30175	Temperature value in °C multiplied by 10. 0 = 0°C ... 400 = 40°C  Note: Only available when 'Supply Air Temperature Sensor' value = 1 (Equipped).		
Outdoor Temperature (signed)	175	30176	Temperature value in °C multiplied by 10. (see note *)  Note: Only available when 'Outdoor Temperature Sensor' value = 1 (Equipped).	✓	✓
Outdoor Temperature	176	30177	Temperature value in °C multiplied by 10. (see note **)  Note: Only available when 'Outdoor Temperature Sensor' value = 1 (Equipped).	✓	✓
Room Temperature A	177	30178	Temperature value in °C multiplied by 10. 0 = 0°C ... 400 = 40°C  Note: Only available when 'Return Air Temperature Sensor' value = 1 (Equipped).	✓	✓
Room CO2 Level	178	30179	CO2 level divided by 10. 0 = 0ppm ... 240 = 2400 and above. [Value 254 = Under detecting] [Value 255 = No sensor]  Note: Only available when 'CO2 Level Sensor' value = 1 (Equipped).		
Fault/Error Code (hex)	179	30180	0x8000 = No error 0x6999 = Bad communication with unit (Refer to Lossnay unit documentation for description of other fault code values)	✓	✓
Fault/Error Code (decimal)	180	30181	8000 = No error 6999 = Bad communication with unit (Refer to Lossnay unit documentation for description of other fault code values)	✓	✓
Energy Consumption	181	30182	Value in kWh multiplied by 10. 0 = 0kWh ... 65535 = 6553.5kWh	✓	✓
Actual Operation Mode	182	30183	0 = Not auto mode 1 = Determining 2 = Heating 3 = Cooling		
Actual Supply Fan Speed	183	30184	0 = Stop 1 = Speed 1 2 = Speed 2 3 = Speed 3 4 = Speed 4	✓	✓

Input Register (Analogue Input)				Applicable Unit Type	
Register Name	Addr	Modicon Address	Details	Lossnay LGH Series	Lossnay VL Series
Actual Extract Fan Speed	184	30185	0 = Stop 1 = Speed 1 2 = Speed 2 3 = Speed 3 4 = Speed 4	✓	✓
Minimum Cooling Setpoint	185	30186	Temperature value in °C multiplied by 10. 0 = 0°C ... 400 = 40°C  Note: Only available when 'Set Temperature on Temperature Control Unit' value = 1 or 2.		
Maximum Cooling Setpoint	186	30187	Temperature value in °C multiplied by 10. 0 = 0°C ... 400 = 40°C  Note: Only available when 'Set Temperature on Temperature Control Unit' value = 1 or 2.		
Minimum Heating Setpoint	187	30188	Temperature value in °C multiplied by 10. 0 = 0°C ... 400 = 40°C  Note: Only available when 'Set Temperature on Temperature Control Unit' value = 1 or 2.		
Maximum Heating Setpoint	188	30189	Temperature value in °C multiplied by 10. 0 = 0°C ... 400 = 40°C  Note: Only available when 'Set Temperature on Temperature Control Unit' value = 1 or 2.		
Minimum Auto Setpoint	189	30190	Temperature value in °C multiplied by 10. 0 = 0°C ... 400 = 40°C  Note: Only available when 'Set Temperature on Temperature Control Unit' value = 1 or 2.		
Maximum Auto Setpoint	190	30191	Temperature value in °C multiplied by 10. 0 = 0°C ... 400 = 40°C  Note: Only available when 'Set Temperature on Temperature Control Unit' value = 1 or 2.		
Number of Fan Speeds	191	30192	Values 1 – 4 valid.	✓	✓
Set Temperature on Temperature Control Unit	192	30193	0 = No set temperature display 1 = RA (Return Air) temperature 2 = SA (Supply Air) temperature		

### 12.3. Coils

Coils are read using function code 01 and written to using either function code 05 or 15. Function code 05 is used when writing to a single coil register, function code 15 is used for writing to multiple coil registers in the same command.

Coil (Digital Output)				Applicable Unit Type	
Register Name	Addr	Modicon Address	Details	Lossnay LGH Series	Lossnay VL Series
Power On/Off	3	00004	0 = Power OFF 1 = Power ON	✓	✓

### 12.4. Discrete Inputs

Discrete Inputs are read using function code 02.

Discrete Input (Digital Input)				Applicable Unit Type	
Register Name	Addr	Modicon Address	Details	Lossnay LGH Series	Lossnay VL Series
Thermo On/Off	80	10081	0 = Thermo OFF 1 = Thermo ON		
Auto Fan Speed Control Availability	81	10082	0 = Not available 1 = Available		
Night Purge	82	10083	0 = Normal operation 1 = In night purge operation  During night-purge operation: - Pressing ON/OFF button starts normal operation. - When pressing the Ventilation button the Lossnay remains in bypass mode	✓	✓
Maintenance Sign	83	10084	0 = Inactive 1 = Active	✓	✓
Filter Sign	84	10085	0 = Inactive 1 = Active	✓	✓
Actual Ventilation Mode	85	10086	0 = Lossnay ventilation 1 = Bypass ventilation	✓	✓
Setpoint 0.5°C Increments Availability	86	10087	0 = Not available 1 = Available		
Heat/Cool or Cool-Only	87	10088	0 = Heat and Cool 1 = Cool only		
Auto Operation Mode Availability	88	10089	0 = Not available 1 = Available		
Heat/Cool or Heat-Only	89	10090	0 = Heat and Cool 1 = Heat only		
Energy Consumption Data Available	90	10091	0 = Not available 1 = Available	✓	✓
Bypass Damper Available	91	10092	0 = Not available 1 = Available	✓	✓
Auto Ventilation Mode Available	92	10093	0 = Not available 1 = Available	✓	✓

Discrete Input (Digital Input)				Applicable Unit Type	
Register Name	Addr	Modicon Address	Details	Lossnay LGH Series	Lossnay VL Series
Operation Mode of Temperature Control Unit	93	10094	0 = Not available (not connected) 1 = Available (connected)		
Outdoor Temperature Sensor	94	10095	0 = Not equipped 1 = Equipped	✓	✓
Return Air Temperature Sensor	95	10096	0 = Not equipped 1 = Equipped	✓	✓
Supply Air Temperature Sensor	96	10097	0 = Not equipped 1 = Equipped		
CO2 Level Sensor	97	10098	0 = Not equipped 1 = Equipped		

### 13. Technical specification

---

Parameter	Min.	Typ.	Max.	Comments
<b><u>Environmental</u></b>				
Operating temperature	-20°C		60°C	
Indoor or outdoor use				Indoor
Altitude		< 2000m		
Relative humidity				90% non-condensing
Pollution degree		2		

## Appendix A – Compatible Air-To-Air units

---

### Indoor Unit Models

#### M Series

MSZ-AP15/20VF	(from Feb 2018)
MSZ-AP25/35/42/50VG(K)	(from Jan 2018)
MSZ-LN18/25/35/50/60VGW/V/R/B	
MSZ-WN25/35VA	
MSZ-DM25/35VA	
MSZ-EF18/22/25/35/42/50VE3W/S/B	
MSZ-EF18/22/25/35/42/50VE2W/S/B	
MSZ-EF18/22VEW/S/B	
MSZ-EF25/35/42/50VEB/W/S-E1	
MSZ-FD25/35/50VA	
MSZ-FH25/35/50VE2	
MSZ-FH25/35/50VE	
MSZ-GA60/71VA	
MSZ-GB50VA	
MSZ-GC22/25/35VA	
MSZ-GE22/25/35/42/50/60/71VA	
MSZ-GF60/71VE2	
MSZ-GF60/71VE	
MSZ-SF15/20VA	
MSZ-SF25/35/42/50VE3	
MSZ-SF25/35/42/50VE2	
MSZ-SF25/35/42/50VE	
MFZ-KJ25/35/50VE2	
MFZ-KJ25/35/50VE	
MFZ-KA25/35/50VA	
MLZ-KP25/35/50VA	(from Feb 2018)
MLZ-KA25/35/50VA	

#### S Series

SEZ-KA35/50/60/71VA	
SEZ-KD25/35/50/60/71VAL	
SEZ-KD25/35/50/60/71VAQ	
SEZ-M25/35/50/60/71DA	(from Mar 2018)
SEZ-M25/35/50/60/71DAL	(from Mar 2018)
SLZ-KF25/35/50/60VA2	
SLZ-KF25/35/50/60VA	
SLZ-M15/25/35/50/60FA	(from Mar 2018)
SLZ-KA25VAL2	
SLZ-KA25/35/50VAL3	
SLZ-KA25/35/50VAQ	
SLZ-KA25/35/50VAQR1	
SLZ-KA25VAQ2	
SLZ-KA25/35/50VAQ3	
SLZ-KA35/50VAL	
SLZ-KA35/50VALR2	
SLZ-KA35/50VALR3	
SLZ-KA35/50VAQR2	

## P Series

PCA-M71HA  
PCA-M50/60/71/100/125/140KA  
PCA-RP35/50/60/71/100/125/140KAQ  
PCA-RP35/50/60/71/100/125/140KAQR2  
PCA-RP50/60/71KAQR1  
PEAD-M35/50/60/71/100/125/140JA  
PEAD-RP50/60/71/125/140EA  
PEAD-RP35/100EA2  
PEAD-RP35/50/60/71/100/125/140JA(L)Q  
PEA-RP200/250GAQR2  
PEA-RP200/250WKA (from Nov 2017)  
PEA-ZM200/250WKA  
PKA-RP35/50HAL  
PKA-RP35/50HALR1  
PKA-RP60/71/100KAL  
PKA-RP60/71/100KALR1  
PLA-SM71/100/125/140EA (from Dec 2017)  
PEAD-SM71/100/125/140JA(L) (from Dec 2017)  
PEAD-SP (all variants from Dec 2017)  
PLA-RP35/50/60/71/EA  
PLA-RP100/125/140EA (from Oct 2017)  
PLA-ZP35/50/60/71/100/125/140EA  
PLA-RP100/125/140AA2  
PLA-RP100/125/140BA  
PLA-RP100/125/140BAR2  
PLA-RP125/140BA2  
PLA-RP100BA3  
PLA-RP140BA2R4  
PLA-RP35/50/60/71AA  
PLA-RP35/50/60/71BA  
PLA-RP35/50/60/71BAR1  
PLA-RP35/50/60/71BAR2  
PLA-RP71BA2  
PLA-ZRP100/125/140BA  
PLA-ZRP100/125/140BAR1  
PLA-ZRP35/50/60/71BA  
PLA-ZRP35/50/60/71BAR1  
PSA-RP71/100/125GA  
PSA-RP71KA  
PSA-RP100/125/140KA (from Oct 2017)  
PLA-SM71/100/125/140EA  
PLA-ZM35/50/60/71/100/125/140EA  
PLA-M35/50/60/71/100/125/140EA  
PKA-M35/50HA  
PKA-M60/71KA  
PKA-M100KA (from Oct 2017)  
PKA-M35/50HAL  
PKA-M60/71KAL  
PKA-M100KAL (from Oct 2017)  
PCA-M35/50/60/71KA  
PCA-M100/125/140KA (from Oct 2017)  
PEAD-M35/50/60/71JA  
PEAD-M100/125/140JA (from Oct 2017)  
PEAD-M35/50/60/71JAL  
PEAD-M100/125/140JAL (from Oct 2017)

## Models Not Supported:

MSZ-HJ25/35VA  
MSZ-HC25/35VA/VAB  
PCA-RP71/125HA/HAQ  
PEA-RP400/500GAQ

## City Multi

Name	From Production	Firmware Version	Serial Number
PLFY-P**VLMD-E	Oct-14	Ver. 10.23 →	4XW***** →
PFFY-P**VLEM-E	Jan-15	Ver. 10.23 →	41W***** →
PFFY-P**VLRM-E	Jan-15	Ver. 10.23 →	41W***** →
PFFY-P**VLRM M-E	Nov-14	Ver. 10.23 →	4YW***** →
PEFY-P**VMH-E	Jan-15	Ver. 10.23 →	41W***** →
PEFY-P**VMH-E-F	Jan-15	Ver. 10.23 →	41W***** →
PEFY-P**VMR-E-L	Jan-15	Ver. 10.23 →	41W***** →
PEFY-P**VMR-E-R	Jan-15	Ver. 10.23 →	41W***** →
PEFY-P**VMHS-E	Jan-15	Ver. 11.17 →	31W***** →
PEFY-P**VMA-ER3.UK	Mar-15	Ver. 10.23 →	5C***** →
PEFY-P**VMAL-ER3.UK	Mar-15	Ver. 10.23 →	5C***** →
PEFY-P**VMS1-ER2.TH	Dec-14	Ver. 10.23 →	4ZM***** →
PEFY-P**VMS1L-ER1.TH	Dec-14	Ver. 10.23 →	4ZM***** →
PLFY-P**VBM-ER3.UK	Jan-15	Ver. 10.29 →	5A***** →
PLFY-P**VBM-E.UK	From first product		
PLFY-P**VCM-E2R1.TH	Jan-15	Ver. 10.29 →	51M***** →
PLFY-P**VCM-E3.TH	From first product		
PLFY-P**VFM-E.TH	From first product		
PMFY-P**VBM-ER4	Jan-15	Ver. 10.29 →	41A***** →
PKFY-P**VKM-ER1.TH	Jan-15	Ver. 10.29 →	51M***** →
PKFY-P**VHM-ER2	Jan-15	Ver. 10.29 →	41A***** →
PKFY-P**VBM-ER3	Jan-15	Ver. 10.29 →	41A***** →
PCFY-P**VKM-ER1	Jan-15	Ver. 10.29 →	41A***** →
PFFY-P**VKM-E2	Jan-15	Ver. 10.29 →	41A***** →

## Hybrid City Multi

### Name

PEFY-WP15-50VMS1-E  
PEFY-WP10VMS1-E  
PEFY-WP20-50VMA-E  
PEFY-WP63-125VMA-E  
PFFY-WP20-50VLRMM-E  
PLFY-WP32-50VBM-E  
PKFY-WP10-25(PKfy chassis basis)  
PKFY-WP10-32(MSZ-AP chassis basis)  
PLFY-WP10-32VFM

## Appendix B – Compatible Air-To-Water units

---

### Ecodan FTC4:

#### Cylinder

EHST20C-VM6HB  
 EHST20C-YM9HB  
 EHST20C-VM6B  
 EHST20C-YM9B  
 EHST20C-VM6EB  
 EHST20C-YM9EB  
 EHST20C-VM6SB  
 EHPT20X-VM2HB  
 EHPT20X-VM6HB  
 EHPT20X-YM9HB  
 EHPT20X-VM6B  
 EHPT20X-YM9B  
 EHST-20CVM2B  
 EHST20C-TM9HB  
 EHPT20X-TM9HB

#### Hydrobox

EHSC-VM6B  
 EHSC-YM9B  
 EHSC-VM6EB  
 EHSC-YM9EB  
 EHPX-VM2B  
 EHPX-VM6B  
 EHPX-YM9B  
 ERSC-VM2B  
 EHSC-VM2B  
 EHSC-TM9B

#### Controller

PAC-IF052B-E  
 PAC-IF051B-E

### Ecodan FTC5:

#### Cylinder

EHST20C-VM2C  
 EHST20C-VM6C  
 EHST20C-YM9C  
 EHST20C-TM9C  
 EHST20C-VM2EC  
 EHST20C-VM6EC  
 EHST20C-YM9EC  
 EHST20C-MEC  
 EHST20C-MHCW  
 EHST20D-VM2C  
 EHST20D-MEC  
 EHST20D-MHC  
 EHST20D-MHCW  
 EHPT20X-VM2C  
 EHPT20X-VM6C  
 EHPT20X-YM9C  
 EHPT20X-TM9C  
 EHPT20X-MHCW

#### Hydrobox

EHSC-VM2C  
 EHSC-VM2EC  
 EHSC-VM6C  
 EHSC-VM6EC  
 EHSC-YM9C  
 EHSC-YM9EC  
 EHSC-TM9C  
 EHSC-MEC  
 EHSD-VM2C  
 EHSD-MEC  
 ERSC-VM2C  
 ERSC-MEC  
 ERSD-VM2C  
 EHPX-VM2C  
 EHPX-YM9C

#### Controller

PAC-IF062B-E

EHPT15X-UKHCW\*  
 EHPT17X-UKHCW\*  
 EHPT21X-UKHCW\*  
 EHPT25X-UKHCW\*  
 EHPT30X-UKHCW\*  
 EHPT21X-UKHSCW\*  
 EHPT25X-UKHSCW\*  
 EHPT30X-UKHSCW\*  
 EHPT15X-UKHLCW\*  
 EHPT17X-UKHLCW\*

\*UK Models

**Ecodan FTC6 & FTC7:****Cylinder**

EHST17D-VM2D  
EHST17D-YM9D  
EHST20D-MED  
EHST20D-VM2D  
EHST20D-VM6D  
EHST20D-YM9D

EHST20D-YM9ED  
EHST20D-TM9D  
EHST30D-MED  
EHST30D-VM6ED  
EHST30D-YM9ED  
EHST30D-TM9ED

EHST20C-MED  
EHST20C-VM2D  
EHST20C-VM6D  
EHST20C-YM9D  
EHST20C-YM9ED  
EHST20C-TM9D

EHST30C-MED  
EHST30C-VM6ED  
EHST30C-YM9ED  
EHST30C-TM9ED

ERST17D-VM2D  
ERST17D-VM6D  
ERST20D-VM2D  
ERST20D-VM6D  
ERST20D-YM9D  
ERST30D-VM2ED

ERST20C-VM2D  
ERST20C-VM6D  
ERST20C-YM9D  
ERST30C-VM2ED  
ERST30D-VM6ED  
ERST30D-YM9ED

EHPT17X-VM2D  
EHPT17X-VM6D  
EHPT17X-YM9D  
ERPT17X-VM2D  
EHPT20X-MED  
EHPT20X-VM6D

EHPT20X-YM9D  
EHPT20X-YM9ED  
EHPT20X-TM9D  
EHPT20X-MHEDW  
ERPT20X-MD  
ERPT20X-VM2D

ERPT20X-VM6D  
EHPT30X-MED  
EHPT30X-YM9ED  
ERPT30X-VM2ED  
ERPT30X-VM6ED

Packaged Cylinder  
EHPT20X-MHEDW

**Hydrobox**

EHSD-MED  
EHSD-VM2D  
EHSD-VM6D  
EHSD-YM9D  
EHSD-YM9ED  
EHSD-TM9D

EHSC-MED  
EHSC-VM2D  
EHSC-VM6D  
EHSC-YM9D  
EHSC-YM9ED  
EHSC-TM9D

EHSE-YM9ED  
EHSE-MED  
ERSD-MED  
ERSD-VM2D  
ERSC-MED  
ERSC-VM2D

ERSD-VM6D  
ERSD-YM9D  
ERSC-VM6D  
ERSC-YM9D  
ERSE-YM9ED  
ERSE-MED

EHPX-MED  
EHPX-VM2D  
EHPX-VM6D  
EHPX-YM9D  
EHPX-YM9ED

ERPX-MD  
ERPX-VM2D  
ERPX-VM6D  
ERPX-YM9D

**Controller**

PAC-IF071B-E  
PAC-IF072B-E  
PAC-IF073B-E

Pre-Plumbed Cylinder - Slimline  
EHPT15X-UKHLDW\*  
EHPT17X-UKHLDW\*

Pre-Plumbed Cylinder - Standard  
EHPT15X-UKHDW\*  
EHPT17X-UKHDW\*  
EHPT21X-UKHDW\*  
EHPT25X-UKHDW\*  
EHPT30X-UKHDW\*

Pre-Plumbed Cylinder - Solar  
EHPT21X-UKHSDW\*  
EHPT25X-UKHSDW\*  
EHPT30X-UKHSDW\*

\*UK Models

**Ecodan Ground Source Heat Pump:**

CRHV-P600YA-HPB

**Ecodan Air Source Heat Pump:**

CAHV-P500YB-HPB

CAHV-R450YA-HPB

**Hot Water Heat Pump**

QAHV-N560YA-HPB

## Appendix C – Compatible Lossnay units

---

### LGH Series

LGH-15-200RVX-E1  
 LGH-150-250RVXT-E1

### VL Vertical Series

VL-250-500CZPVU-R-E  
 VL-250-500CZPVU-L-E

## Appendix D – Compatible E-Series Chiller units

---

Type	Model	Capacities
Cooling Only	EACV-P900YA(L)(-H)(-N)(-BS)	90kW, 180kW, 270kW, 360kW, 450kW, 540kW
	EACV-P1500YB(L)(-N)(-BS)	150kW, 300kW, 450kW, 600kW 750kW, 900kW
	EACV-M1500YCL(-N)(-BS)	150kW, 300kW, 450kW, 600kW 750kW, 900kW
	EACV-P1800YB(L)(-N)(-BS)	180kW, 360kW, 540kW, 720kW, 900kW, 1080kW
	EACV-M1800YCL(-N)(-BS)	180kW, 360kW, 540kW, 720kW, 900kW, 1080kW
	ERCV-M900YA	90kW
	EACV-M1500YC EACV-M1800YC	150kW 180kW
Heating/Cooling	EAHV-P900YA(L)(-H)(-N)(-BS)	90kW, 180kW, 270kW, 360kW, 450kW, 540kW
	EAHV-P1500YB(L)(-H)(-N)(-BS)	150kW, 300kW, 450kW, 600kW 750kW, 900kW
	EAHV-M1500YCL(-N)(-BS)	150kW, 300kW, 450kW, 600kW 750kW, 900kW
	EAHV-P1800YB(L)(-H)(-N)(-BS)	180kW, 360kW, 540kW, 720kW, 900kW, 1080kW
	EAHV-M1800YCL(-N)(-BS)	180kW, 360kW, 540kW, 720kW, 900kW, 1080kW
	EAHV-P1500YB	150kW
	EAHV-M1500YC	150kW
	EAHV-P1800YB	180kW
	EAHV-M1800YC	180kW

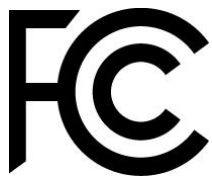

Electrical  
Safety  
E114220

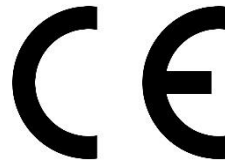

UK  
CA

Please be sure to put the contact address/telephone number on  
this manual before handing it to the customer.

**mitsubishi electric uk**

MITSUBISHI ELECTRIC UK, TRAVELLERS LANE, HATFIELD, HERTFORDSHIRE, AL10 8XB