

Mitsubishi Electric Air Conditioner Network System

DIDO controller

PAC-YG66DCA

Installation/Instruction Manual



Table of Contents

	Page
1. Safety Precautions	1
2. Usage	2
3. Parts List.....	2
4. Specifications	3
4-1. Device Specifications	3
4-2. External Dimensions.....	4
5. Example of System Configuration	4
6. Installation	5
6-1. Parts Purchased Separately.....	5
6-2. Installation Instructions	6
7. Wiring Instructions	7
7-1. Terminal Diagram	7
7-2. Connecting the Power and M-NET Transmission Lines.....	8
7-3. Connecting the Signal Lines.....	8
7-3-1. Standard Terminals (Channels 1 and 2).....	9
(1) Inputs.....	9
(a) Non-voltage a-contact Inputs	9
(2) Outputs	9
(a) Non-voltage Relay Contact Outputs	9
(b) Transistor Outputs (Open Collector).....	10
7-3-2. Expansion Connectors (Channels 3 to 6).....	11
(1) Expansion Inputs/Outputs	11
8. Initial Settings	12
9. Dip Switch Functions	13
10. LED Display Designations	14
10-1. Operation Status Displays	14
10-2. Communication Error Displays	15
11. System Operation Test.....	16

Before using the device, carefully read this installation/instruction manual to ensure proper operation.
Keep this manual for future reference and give it to the technician when the device is reinstalled or repaired.

1 Safety Precautions

- Thoroughly read the following safety precautions before use.
- Hazards that can occur from incorrect handling are classified by the symbols below:

 Warning	Incorrect handling can result in death, serious injury, etc.
 Caution	Incorrect handling can result in bodily injury and/or structure damage.

- After reading this manual, keep this manual for future reference. When the device is reinstalled or repaired, give this manual to those who provide these services. When the user changes, make sure that the new user receives this manual.

WARNING

Only a dealer or qualified technician should install, relocate, reinstall, or repair the device.
Improper installation or repair may result in electrical shock or fire.

Properly install the device on a stable, load-bearing surface.
Device installed on an unstable surface may fall and cause injury.

Only use the specified cables; securely connect each so that the terminals do not bear any cable weight.
Improperly connected or short-circuited cables may produce heat and cause a fire.

Do not make any modifications or alternations to the device.
Modifications or improper repair may result in electric shock or fire. Consult your dealer for repair.

All electrical work should be performed by an authorized electrician according to local regulations and instructions outlined in this manual.
Capacity shortage to the power supply circuit or improper installation may result in electrical shock or fire.

Properly install the device according to the instructions in this Installation/Instruction Manual.
Improper installation may result in electric shock or fire.

CAUTION

Do not install the device in a location where a flammable gas leak may occur.
Gas may leak, collect around the device, ignite, and/or explode.

Do not install the device in environments where large amounts of oil (including machine), sulfidizing gas, or acidic, alkaline, chemical sprays are present.
These types of substances may damage internal parts, cause device performance to be reduced, and cause electrical shock.

When installing the device in a hospital, communication facilities, etc., provide sufficient protection against frequency noise.
Power generators and inverters, high-frequency medical, or radio communication equipment may interfere with the normal operation of this device. Subsequently, the device may also affect medical treatment, image broadcasting, etc., by creating frequency noise.

Include some slack in the power supply wires.
Tension on the wires may cause them to excessively heat up and/or break, resulting in a fire.

Do not install the device in a location where there is direct sunlight or where the temperature may become greater than 40°C (104°F) or less than 0°C (32°F).
If the device is installed in such place, it may result in deformation or malfunctions.

Do not install the device in a bathroom, kitchen, or any room where steam could form. Condensation may develop and cause electrical shock and/or the device to malfunction.

Use standard wires with the proper current capacity to avoid the possibility of current leak, excessive heat, and/or fire.

Do not touch the main circuit board; also, make sure that dust does not accumulate on the circuit board.

Do not immerse the device in water.
Doing so may lead to electric shock or malfunctions.

The maximum applied voltage for the device is 24 VDC - do not use with an AC power source. (The maximum applied voltage for the M-NET terminal is 30 VDC.)
Using the incorrect voltage may result in device failure, ignition, and/or fire.

2 Usage

The DIDO controller is used in combination with a G(B)-50A to operate general-purpose equipment, as well as to monitor operating and error status. It is equipped with two sets of standard terminals (Channels 1 and 2), and four sets of expansion connectors for the input/output terminals. Expansion cable is optional.

Other devices can only be controlled from G(B)-50A Web browser and TG-2000A. Operation cannot be monitored or performed from the G-50A LCD.

In addition, this device includes a function that interlocks M-NET devices such as indoor units, LOSSNAY, general equipment, etc.

Please refer to the operating manual for the Maintenance Tool for details on interlock settings.

⚠ Caution: Usage Restrictions

- Mitsubishi Electric does not take financial responsibility for damages caused by issues beyond our control or special circumstances (predicable or unpredictable); and secondary or accidental damages, and damages to other objects. We also do not take financial responsibility for opportunities lost as a result of device failure, or electrical power failure at the end-user site.
Mitsubishi Electric does not take financial responsibility caused by end-users' requests including, but not limited to, device testing, startup, readjustment, and replacement.
- Do not use this device in disaster prevention, security, or "critical to life" applications.
- It is recommended to provide an external switch for general-purpose equipment in case of a failure of the DIDO controller or a peripheral part.

3 Parts List

The following parts should be included in your shipment:

Number	Part Name	Quantity
1	DIDO controller	1
2	Installation/instruction manual (this document)	1

* In addition to the parts listed above, see your local Mitsubishi Electric dealer to purchase the other parts necessary to operate this device (Refer to section 6-1). Furthermore, depending on the application, other Mitsubishi Electric parts may be required. For details, refer to "6. Installation".

4 Specifications

4-1. Device Specifications

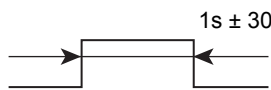
Item	Rating and Specification					
Power Supply	24 VDC±10%: 5 W (*1)			Screw terminal block (M3) (*9)		
Interface	M-NET communication		17 to 30 VDC (*2)		Screw terminal block (M3) (*9)	
	Standard	Output (*3)	ON/OFF, (ON) (*4)	Non-voltage Relay contact (2)	Applied load MAX: 24 VDC, 5 W MIN: 5 VDC, 2 mW * AC loads cannot be connected.	Screw terminal block (M3.5) (*9)
				Transistor (2)	24 VDC 40 mA or less (*5)	Screwless terminal block
			(OFF) (*4)	Non-voltage Relay contact (2)	Applied load MAX: 24 VDC, 5 W MIN: 5 VDC, 2 mW * AC loads cannot be connected.	Screw terminal block (M3.5) (*9)
				Transistor (2)	24 VDC 40 mA or less (*5)	Screwless terminal block
	Input	ON/OFF	Non-voltage a contact (2 each)	24 VDC 1 mA or less (*6)	Screwless terminal block	
		Error/Normal				
	Expansion	Output	ON/OFF, (ON) (*4)	Transistor (4 each)	24 VDC 40 mA or less (*5)	9 pin connector
			(OFF) (*4)			
		Input	ON/OFF	24 VDC input (4 each)	24 VDC 1 mA or less (*7)	9 pin connector
Error/Normal						
Output Pulse Width		1s ± 30 ms				
Interlock Function	Interlock M-NET devices and output contacts according to status of input contacts. (*8)					
Environment Conditions	Temperature	Operating temperature range	0 to 40°C [32°F to 104°F]			
		Storage temperature range	-20 to 60°C [-4°F to 140°F]			
	Humidity	30 to 90%RH (no condensation)				
Dimensions	200 (W) × 120 (H) × 45 (D) mm / 77/8 (W) × 43/4 (H) × 125/32 (D) in					
Weight	0.6 kg / 13/8 lb					
Time Backup During Power Failure	In the event of power failure or shut-off, the internal capacitor will continue to track time for approximately one week. (The internal capacitor takes about 24 hours to fully charge; a replacement battery is not necessary.)					
Installation Environment	Inside a control panel (indoors) * Use this product in a hotel, a business office environment or similar environment.					

*1: For details, refer to "6-1. Parts Purchased Separately".

*2: Supply electric power from a power unit for the transmission line or an outdoor unit. Furthermore, the power consumption factor of the M-NET circuitry of this device is "1/4" (equivalent to one ME Remote Controller).

*3: Non-voltage Relay contact or transistor is available for output. Only one can be used at a time.

*4: () is in the case of a pulse.

*5: The output is open collector type. Power must be supplied from an external power source to the output circuit of this device.

*6: Power is supplied from this device to the external contacts.

*7: Power must be supplied from an external power source.

*8: Interlock control is performed from the Maintenance Tool. For details, refer to the operation manual for the Maintenance Tool.

*9: M3 and M3.5 are sizes of the screw on the terminal block (ISO metric screw thread). The number indicates the screw diameter (mm).

4-2. External Dimensions

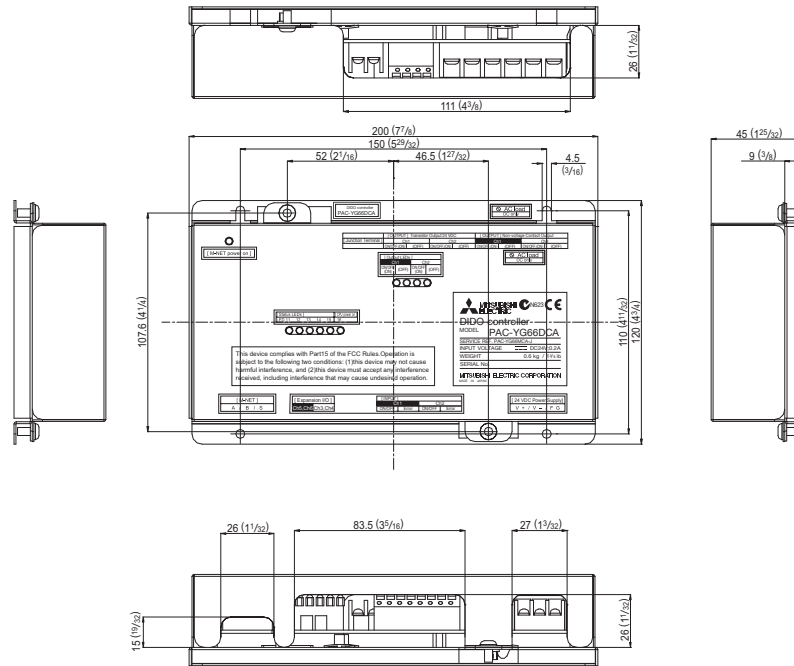

Unit: mm (in)

5 Example of System Configuration

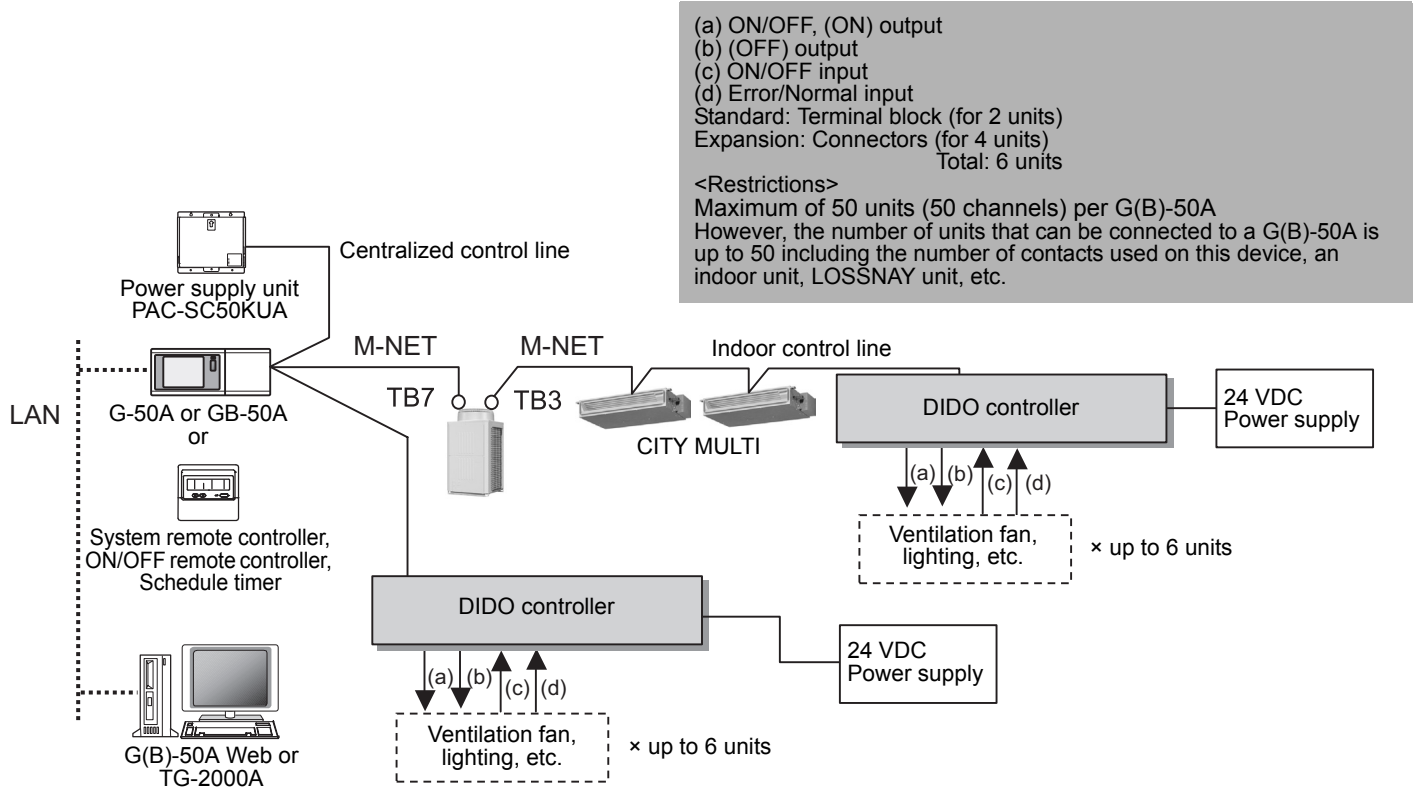

* This figure omits the power supply line and only shows the transmission line.

Note:

- For the shield ground of the M-NET centralized control line, use single-point grounding at the power unit for the transmission line. However, when supplying electric power to the M-NET centralized control line from the R410A series outdoor unit without using a power supply unit for the transmission line, use single-point grounding at the TB7 of that outdoor unit. Furthermore, when connecting this device to the M-NET indoor control line, use grounding at the TB3 for each outdoor unit system.
- If the M-NET transmission line of this device is connected to the M-NET indoor control line and the outdoor unit is down because, for example, the power supply is interrupted for servicing or there is a failure, the DIDO controller cannot be controlled from the system controller.
- Controlling the system remote controller, ON/OFF remote controller, and schedule timer is only possible with channel 1 of a standard terminal block.
- DIDO controller can only be monitored or performed from G(B)-50A Web browser and TG-2000A. Operation cannot be monitored or performed from the G-50A LCD.
- When G(B)-50A is connected, monitoring control can only be performed from G(B)-50A Web or TG-2000A. Monitoring control cannot be performed from the system remote controller, ON/OFF remote controller or schedule timer.

6 Installation

6-1. Parts Purchased Separately

Prepare the following parts to install this device.

Required Part	Specification
Unit fixing screws	M4 screw × 4 (*M4: ISO metric screw thread)
Power supply for this device	<p>Commercially available power source: 24 VDC±10% 0.2 A (Minimum loading), SELV circuit, power line with grounding terminal</p> <p>Ripple noise: Lower than 200 mVp-p</p> <p>Compatible specification</p> <p>Authorized or CE marked products</p> <p>Subject to regulations: - IEC60950 (or EN60950) - CISPR22/24 (or EN55022/24) - IEC61000-3-2/3-3 (or EN61000-3-2/3-3)</p> <p>When using transistor output (including extension output) for the 24 VDC output of this device, increase the capacity to match the number used.</p> <ul style="list-style-type: none"> • 1 set used: 0.3 ADC (Minimum) • 2 sets used: 0.4 ADC (Minimum) • 3 sets used: 0.5 ADC (Minimum) • 4 sets used: 0.6 ADC (Minimum) • 5 sets used: 0.7 ADC (Minimum) • 6 sets used: 0.8 ADC (Minimum) <p>* The increase of the power supply capacity is 0.1 ADC for every set.</p>
Power line	Use a sheathed vinyl cord or cable. At least 0.75 mm ² (AWG18)
M-NET transmission line	<p>Type of the cable: Sheathed vinyl cords or cable which comply with the following specifications or equivalent.</p> <ul style="list-style-type: none"> • CPEV Φ1.2 mm to Φ1.6 mm • CVVS 1.25 mm² to 2 mm² (AWG 16 to 14) * CPEV: PE insulated PVC jacketed shielded communication cable * CVVS: PVC insulated PVC jacketed shielded control cable PE: Polyethylene PVC: Polyvinyl chloride <p>Power needs to be supplied to the M-NET circuitry of this device. Use an outdoor unit or a separately purchased power supply unit for the transmission line.</p>
Signal lines	<p>Use electric wire of an appropriate size for the terminal block of this device.</p> <p>Electric wire size … (1) Solid wire: Φ0.65 mm (AWG21) – Φ1.2 mm (AWG16) (2) Stranded wire: 0.75 mm² (AWG18) – 1.25 mm² (AWG16) Single strand: At least Φ0.18 mm</p> <p>To use an expansion input/output, use a separately purchased external input/output adapter.</p>

[Parts to be Purchased Separately]

Name	Model	Application	Remark
Power supply unit	PAC-SC50KUA	Power supply to the M-NET transmission line	This is not required when power is to be supplied from an outdoor unit.
External I/O adapter	PAC-YG10HA	Connection adapter for using an expansion input/output	This is required when an expansion input/output is used.

[Commercially available parts]

Name	Application	Remark
External 24 VDC power source	Supplies power when to use the DIDO controller or transistor output.	Refer to "Power supply for this device" in "Required Part" above for the power supply capacity.
Relay device	Requires commercially available relay device depending on the electric specifications with an external device.	

6-2. Installation Instructions

The DIDO controller PAC-YG66DCA does not have a waterproof structure.

Be sure to install the DIDO controller inside a control panel that is located indoors.

Prepare a control panel capable of storing this device such as the one shown in the figure. (Install the device in a control panel strong enough to withstand a weight of 0.6 kg [$1\frac{3}{8}$ lb].)

This device can be installed horizontally, or as shown below, vertically. The following diagram also provides a rough estimate of how much space is required around the installation.

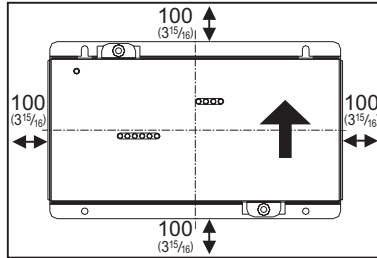

Size of the device: 200 (W) × 120 (H) × 45 (D) mm/
77/8 (W) × 43/4 (H) × 125/32 (D) in

Unit: mm (in)

Note: The space shown above does not include space for peripherals. Additionally, the amount of space necessary varies according to the functions that are used and the wiring method. Secure enough space appropriate for the type of installation.

- (1) Fix the top of this device to the control panel at two points by loosely tightening the screws (M4) that were procured locally. Fix the bottom in place with two screws and then tighten all four of the screws.

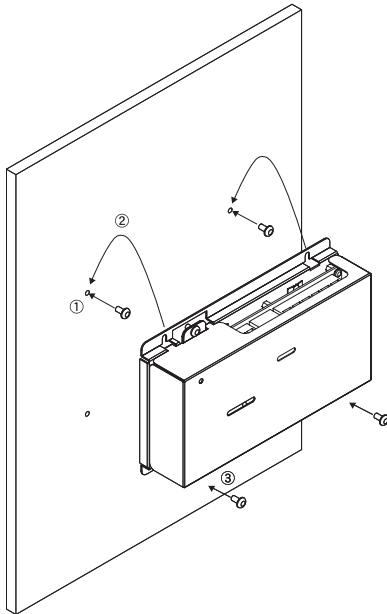

Screw pitch

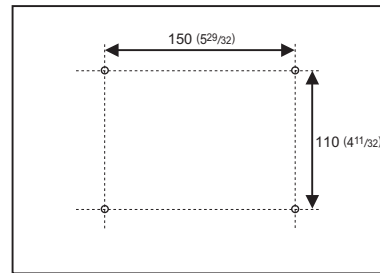

Unit: mm (in)

- (2) To remove the cover, as shown in the figure, remove the two screws for fixing the cover in place and then remove the cover by unhooking the upper hook section from the lower case. To attach the cover, hook the upper hook section on the lower case and then fix the cover in place with the two screws that were removed.

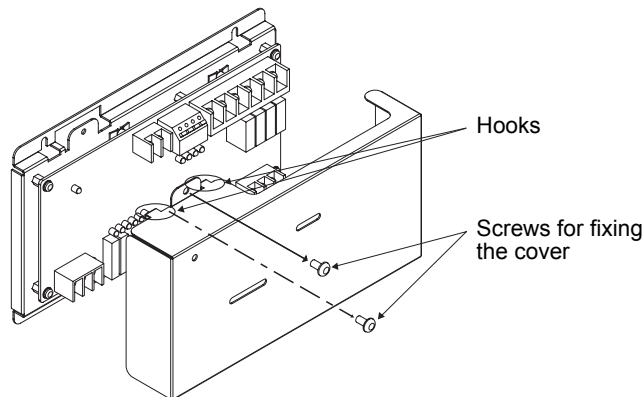

Note: Two hooks are located on the upper section of the cover.

(3) Refer to "7. Wiring Instructions" and connect the wires for the power line, M-NET transmission line, and input/output signal lines.

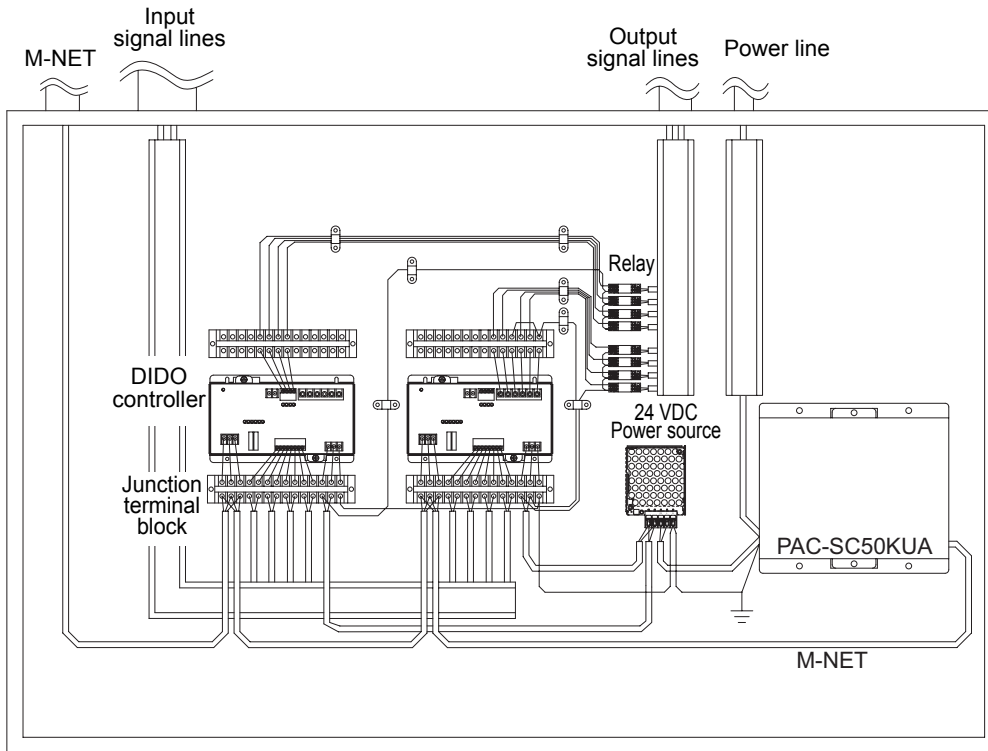

Caution:

- Perform wiring so that the terminal block is not strained. If strained, use a wire guide or junction terminal to alleviate the stress on the terminal block.
- Do not connect the wires directly from the top of the control panel to the terminal block. Moisture may enter this device along the wiring and cause electric shock or fire.

Note: The input signal lines should not come into contact with or be installed alongside the M-NET transmission line, power supply line and output signal lines.

Diagram Image (Installed within a Control Panel)

* The wiring in the diagram has been simplified.

7 Wiring Instructions

7-1. Terminal Diagram

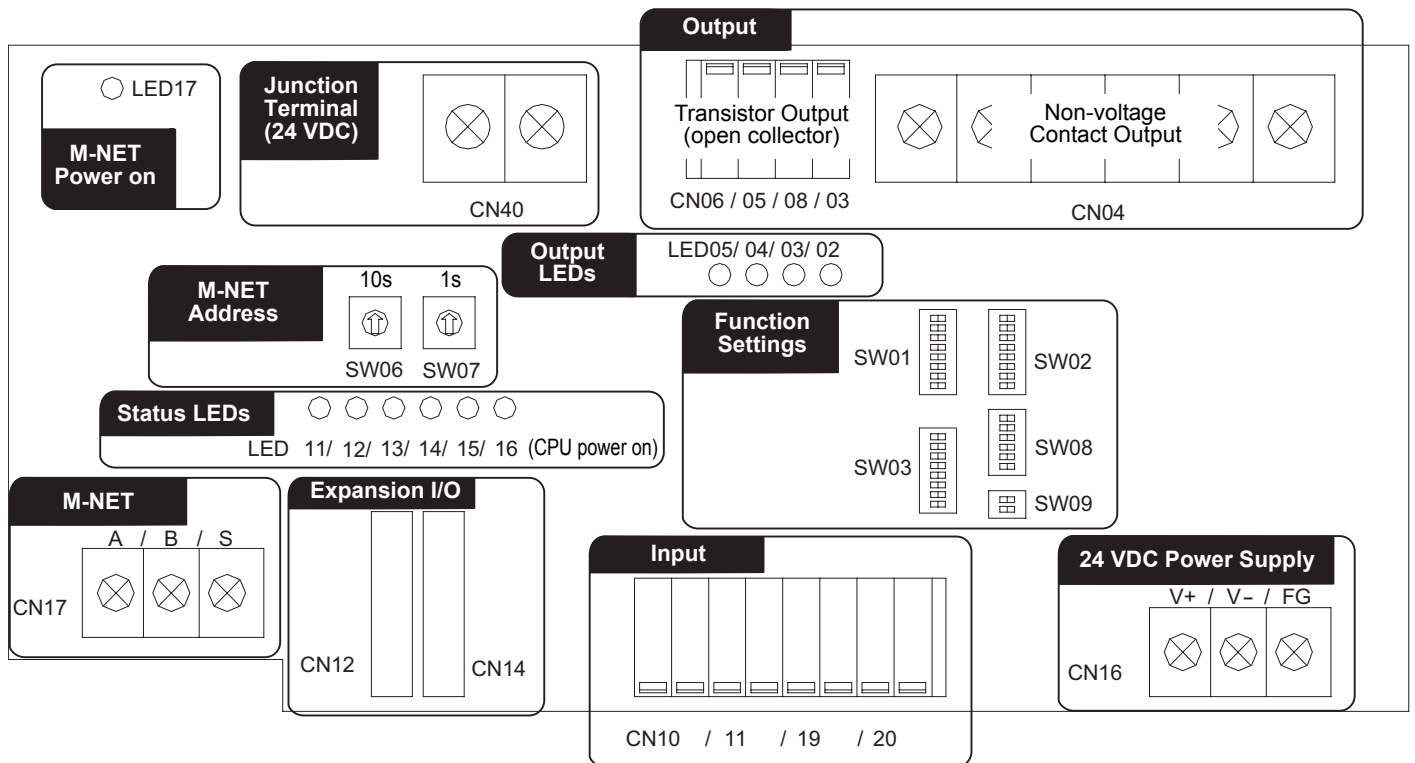

7-2. Connecting the Power and M-NET Transmission Lines

Tightening torque for terminal screws: 1 N·m

Connect the M-NET transmission line of this device to a power supply unit (PAC-SC50KUA) for the M-NET transmission line or an outdoor unit (either a centralized control line or indoor control line can be connected).

* Only the M-NET circuitry of this device receives the power from the M-NET transmission line. The power consumption factor is "1/4" (equivalent to one ME Remote Controller).

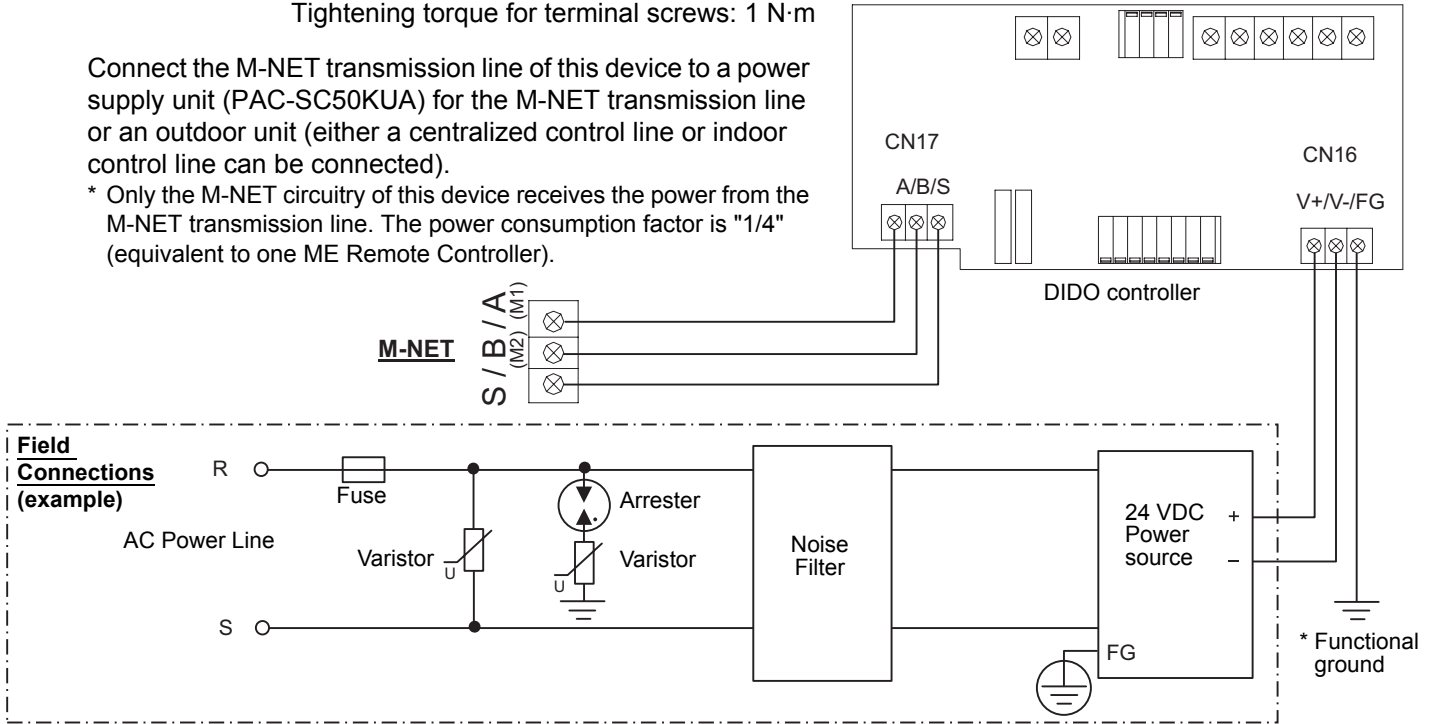

Figure 7-1 Example of Connecting the Power Line and M-NET Transmission Line

⚠ Caution:

- Use a power line and M-NET transmission line that satisfy the specifications described in "6-1. Parts Purchased Separately".
- Attach a circuit comprising the following components to the supply primary side of the 24 VDC power supply.
(1) Varistor, (2) Arrester, (3) Noise filter, (4) Fuse
- It is important to pay attention to the polarity when connecting to the 24 VDC power supply terminal block. Connecting the positive and negative in the reverse order will cause a failure.
- Fix the power line and M-NET transmission line in place on the outside to ensure that the terminal block is not affected by any external force.
Not securely connecting and fixing the wires in place may cause heat generation and fire.
- Make sure that the copper wiring is not short-circuiting the plates (cover, lower case) or neighboring wires.
Cover the shielded line of the M-NET transmission line with materials such as vinyl tape and prevent short-circuiting with the plates.

Note: If the M-NET transmission line of this device is connected to an M-NET indoor control line and the outdoor unit is down because, for example, the power supply is interrupted for servicing or there is a failure, the DIDO controller cannot be controlled from the system controller.

7-3. Connecting the Signal Lines

- Separately procure the relay, power supply for the relay, terminal block, and cable locally.
- The maximum wire length is 100 m (328 ft). However, since the use of long wires makes the device susceptible to noise, using wires shorter than 10 m (32.8 ft) is recommended.
- Connect another relay within 10 m (32.8 ft) from DIDO controller to extend the input line.

7-3-1. Standard Terminals (Channels 1 and 2)

(1) Inputs

(a) Non-voltage a-contact Inputs

* To use these, various settings need to be configured. Refer to "8. Initial Settings".

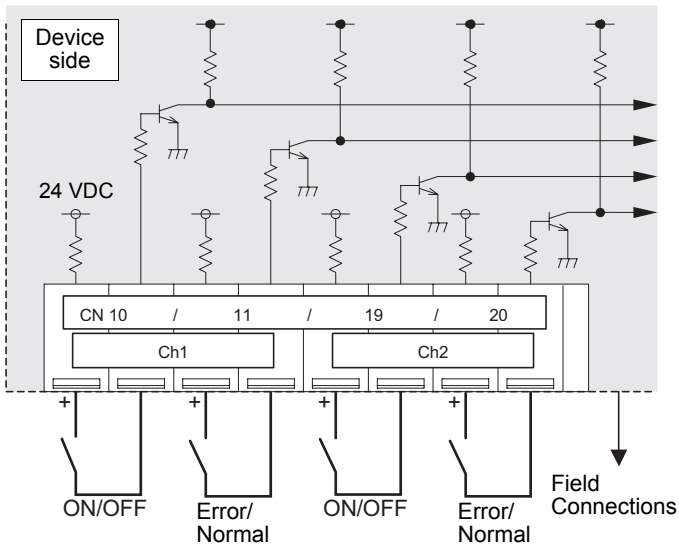
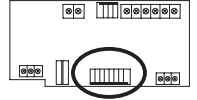

Contacts closed : Operating (ON); detected an error
 Contacts open : Stopped (OFF); detected as normal

* Error/normal detection becomes inverted from contact open/closed logic for a b-contact setting.

Note:

- Connect the operate/stop (ON/OFF) inputs so that closing the contact operates (ON) the device and opening the contact stops (OFF) the device.
- The error/normal inputs of channels 1 and 2 can be switched between a-contact and b-contact. For details, refer to "9. Dip Switch Functions".

⚠ Caution:

- The polarity of the input terminals is important, so be sure to match the polarity when using contacts that have polarity.
- Select a contact with a minimum applicable load of 1 mADC or less.
- Supply 24 VDC 1 mA from the positive terminal to the external contacts.
- Do not install alongside or in contact with other wires.
- Strip 12 ± 1 mm ($15/32 \pm 1/32$ in) of the wire coating and insert firmly into the terminal.
- Make sure that the copper wiring is not short-circuiting the plates (cover, lower case) or neighboring wires.
- Perform wiring so that the terminal block is not strained. If strained, use a wire guide or junction terminal to alleviate the stress on the terminal block.

(2) Outputs

* Non-voltage Relay contact or transistor is available for output. Only one can be used at a time.

(a) Non-voltage Relay Contact Outputs

* To use these, various settings need to be configured. Refer to "8. Initial Settings".

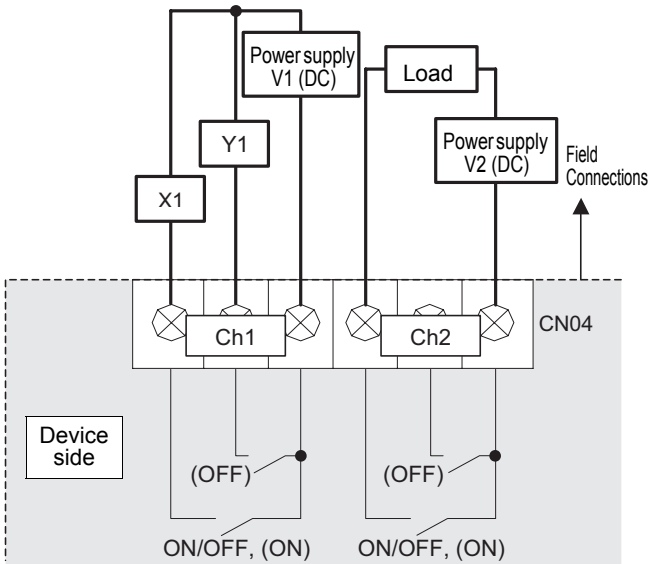
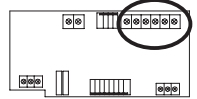

() is in the case of a pulse.

Tightening torque for terminal screws: 1 N·m

Operate (ON) output : Contacts closed

Stop (OFF) output : Contacts open

* Upon pulse output, the (ON), (OFF) contacts close according to the output content. ((ON) and (OFF) refer to the junctions in the diagram.)

⚠ Caution:

- To use X1 and Y1 relay, obtain one that satisfies the following specifications.
 Operating coil
 [Applied load]
 MAX: 24 VDC, 5 W (Built-in diode)
 MIN: 5 VDC, 2 mW (Built-in diode)
 *1 AC loads cannot be connected.
 *2 Provide a power supply (V1, V2) that matches the load and relay to be used.
- To drive a direct load, use ones within the following.
 [Applied load]
 MAX: 24 VDC, 5 W
 MIN: 5 VDC, 2 mW
 * AC loads cannot be connected.
- Make sure that the copper wiring is not short-circuiting the plates (cover, lower case) or neighboring wires.
- Perform wiring so that the terminal block is not strained. If strained, use a wire guide or junction terminal to alleviate the stress on the terminal block.
- Do not connect the wires directly from the top of the control panel to the terminal block. Moisture may enter this device along the wiring and cause electric shock or fire.

(b) Transistor Outputs (Open Collector)

* To use these, various settings need to be configured. Refer to "8. Initial Settings".

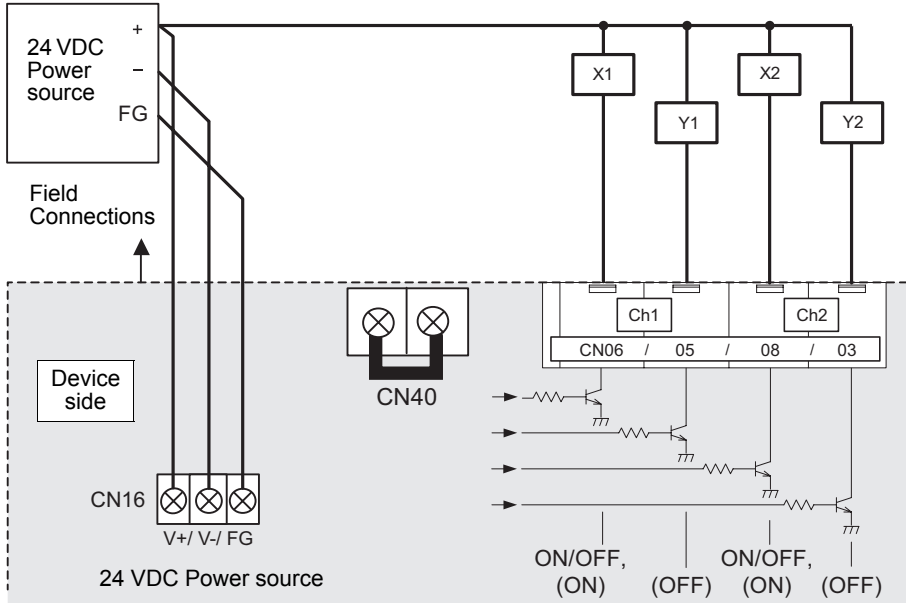
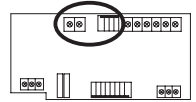

() is in the case of a pulse.

Tightening torque for terminal screws: 1 N·m

Note: The junction terminal block CN40 (for 24 VDC) is provided. Use them as relay terminals if necessary.

Operate (ON) output : Transistor ON (sink)

Stop (OFF) output : Transistor OFF (open)

* Upon pulse output, the (ON),(OFF) transistors turn ON (sink) according to the output content. ((ON) and (OFF) refer to the junctions in the diagram.)

⚠ Caution:

- When X1, X2, Y1 and Y2 relays are used, select ones that satisfy the following specifications.
 - Operating coil
 - Rated voltage: 24 VDC (Built-in diode)
 - Power consumption: 0.9 W or less
 - (*1) Be sure to use the ones with the voltages rated above. Exceeding the rated voltage may affect the ON/OFF of other outputs.
 - (*2) When using a separate power supply for this device, connect GND of the power supply to V- of CN16 of the terminal block of this device.
 - (*3) Use a relay with a withstanding voltage of at least 2000 VAC between the coil and contact. Otherwise, there is the likelihood of an electric shock or fire.
- Strip 12±1 mm (15/32 ±1/32 in) of the wire coating and insert firmly into the terminal.
- Make sure that the copper wiring is not short-circuiting the plates (cover, lower case) or neighboring wires.
- Perform wiring so that the terminal block is not strained.
 - If strained, use a wire guide or junction terminal to alleviate the stress on the terminal block.
- Do not connect the wires directly from the top of the control panel to the terminal block.
 - Moisture may enter this device along the wiring and cause electric shock or fire.

7-3-2. Expansion Connectors (Channels 3 to 6)

(1) Expansion Inputs/Outputs

- * Purchase an optional external input/output adapter (model: PAC-YG10HA) when using expansion inputs/outputs.
- * To use these, various settings need to be configured. Refer to "8. Initial Settings".

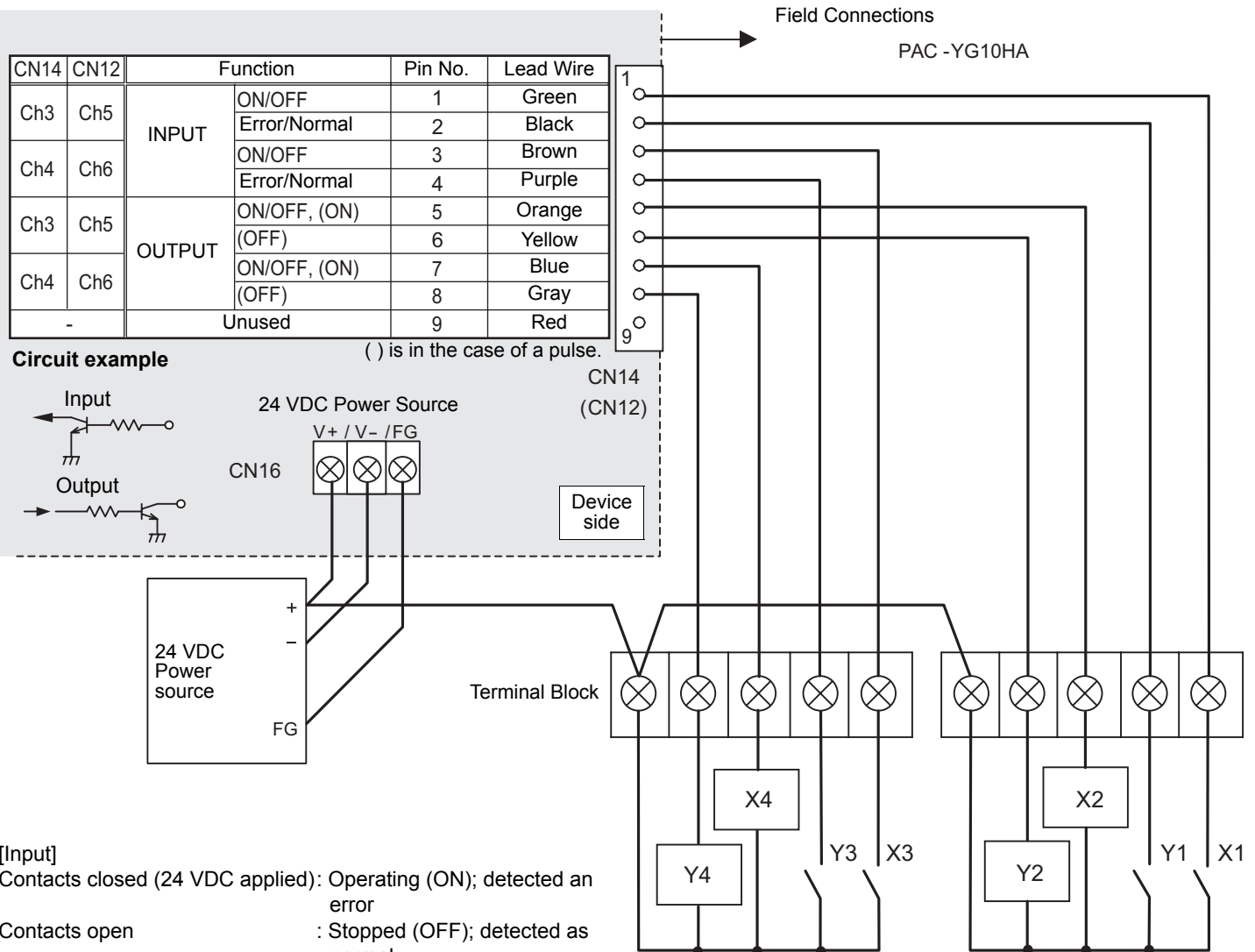
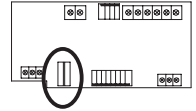

- [Input]
 Contacts closed (24 VDC applied): Operating (ON); detected an error
 Contacts open : Stopped (OFF); detected as normal
- * Error/normal detection becomes inverted from contact open/closed logic for a b-contact setting.
- [Output]
 Operate (ON) output : Transistor ON (sink)
 Stop (OFF) output : Transistor OFF (open)
- * Upon pulse output, the (ON), (OFF) transistors turn ON (sink) according to the output content. ((ON) and (OFF) refer to the junctions in the diagram.)

⚠ Caution:

- When using X1, X2, X3, X4, Y1, Y2, Y3 and Y4 relays, select ones that satisfy the following specifications.
 - Operating coil
 - Rated voltage: 24 VDC (Built-in diode)
 - Power consumption: 0.9 W or less
 - (*1) Be sure to use the ones with the voltages rated above. Exceeding the rated voltage may affect the ON/OFF of other outputs.
 - (*2) When using a separate power supply for this device, connect GND of the power supply to V- of CN16 of the terminal block of this device.
 - (*3) Use a relay with a withstanding voltage of at least 2000 VAC between the coil and contact. Otherwise, there is the likelihood of an electric shock or fire.
- Select a contact with a minimum applicable load of 1 mADC or less for the input contact.
- Do not install alongside or in contact with other wires.

8 Initial Settings

After completing the procedures described in "6. Installation" and "7. Wiring Instructions", set the initial settings in accordance with the procedure described below.

(1) M-NET address settings

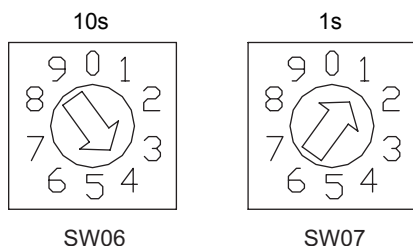

In the case of address "41"

Note:

- An address from 01 to 50 can be set.
- Set an address that is not the same as that of another unit.

The address is set to "01" at factory default.

(2) Use the dip switches to select functions.

Select the function required for each input/output channel to be used.

The switch assignment for each channel is shown below. Configure each of the settings while referring to "9. Dip Switch Functions".

Setting	Channel Used					
	Standard		Expansion			
	Ch1	Ch2	Ch3	Ch4	Ch5	Ch6
Emergency stop command enable setting	SW01-1	SW02-1	SW03-1 (The setting is common to channels 3 to 6)			
Error input logic setting	SW01-2	SW02-2	SW03-2 (The setting is common to channels 3 to 6)			
Error interlock stop output setting	SW01-3	SW02-3	SW03-3 (The setting is common to channels 3 to 6)			
Output operation setting for power failure recovery	SW01-4	SW02-4	SW03-4 (The setting is common to channels 3 to 6)			
Output signal setting	SW01-5	SW02-5	SW03-5 (The setting is common to channels 3 to 6)			
Selection of status display mode	SW03-6, SW03-7					
Error display is cancelled (for 10 seconds).	SW03-8		-			
Error input usage setting	SW08-1	SW08-2	SW08-3	SW08-4	SW08-5	SW08-6

(3) Turn on the power of this device.

Verify that the LED16 (CPU power on) and LED17 (M-NET power on) are lit.

(4) Set the group settings so that this device is a target for control from the system controllers.

Set the group settings (contact numbers to use (channel)) in the system controllers (G(B)-50A, TG-2000A, system remote controller, schedule timer, and ON/OFF remote controller) and then start up this device.

* With the system remote controller, schedule timer, and ON/OFF remote controller, group settings can only be configured for channel 1. Furthermore, when a G(B)-50A is connected, monitoring and controlling are possible only from that G(B)-50A Web browser or a TG-2000A, not from the system remote controller, ON/OFF remote controller, or schedule timer.

(5) Set the time.

Set the current time from a system controller (G(B)-50A, TG-2000A, system remote controller, or schedule timer) or a Maintenance Tool.

(6) To use the interlock control function, perform settings from the Maintenance Tool.

Perform settings such as interlocking criteria for this device with the Maintenance Tool.

For details on setting procedures, refer to the operation manual for the Maintenance Tool.

9 Dip Switch Functions

Switch	Channel	Function Setting	OFF	ON	Remark	
SW01	Channel 1 (standard)	Emergency stop command enable setting	Disabled	Enabled	Select the output operation for when an emergency stop command is received from a system controller.	
		Error input logic setting	a-contact	b-contact	–	
		Error interlock stop output setting	No	Yes	Select whether to interlock and stop output for error input.	
		Output operation setting for power failure recovery	Stop	Recover to state prior to power failure	Select the output operation for when there is a recovery from a power failure.	
		Output method setting	Level output	Pulse output	–	
	6	Unused			Set to OFF	
	7	Unused			Set to OFF	
	8	Unused			Set to OFF	
SW02	Channel 2 (standard)	Emergency stop command enable setting	Disabled	Enabled	Select the output operation for when an emergency stop command is received from a system controller.	
		Error input logic setting	a-contact	b-contact	–	
		Error interlock stop output setting	No	Yes	Select whether to interlock and stop output for error input.	
		Output operation setting for power failure recovery	Stop	Recover to state prior to power failure	Select the output operation for when there is a recovery from a power failure.	
		Output method setting	Level output	Pulse output	–	
	6	Unused			Set to OFF	
	7	Unused			Set to OFF	
	8	Unused			Set to OFF	
SW03	Channel 3 to 6 (standard)	Emergency stop command enable setting	Disabled	Enabled	Select the output operation for when an emergency stop command is received from a system controller.	
		Error input logic setting	a-contact	b-contact	–	
		Error interlock stop output setting	No	Yes	Select whether to interlock and stop output for error input.	
		Output operation setting for power failure recovery	Stop	Recover to state prior to power failure	Select the output operation for when there is a recovery from a power failure.	
		Output signal setting	Level output	Pulse output	–	
	6	Selection of status display mode:		SW03-6	SW03-7	Select the display mode for the status display LED mode.
	7	(1) Normal display (input status or error status of channels 1 and 2):	OFF	OFF		
		(2) Operation input status display of channels 3 to 6:	OFF	ON		
	(3) Operation output status display of channels 3 to 6:	ON	OFF			
	(4) Error input status display of channels 3 to 6:	ON	ON			
8	Error display is cancelled (for 10 seconds).	Change the switch to ON once and then return it to OFF.		Only enabled while communication error status is displayed. * The communication error status display is masked for 10 seconds and the status set with SW03-6 and 7 is displayed.		
SW06	M-NET address		(Address 10s) 0 to 9 (decimal)		An address from 01 to 50 can be set. Set an address that is not the same as that of another unit.	
SW07			(Address 1s) 0 to 9 (decimal)			
SW08	Channel 1 (standard)	Error input usage setting	No	Yes	Select whether to use error/normal input for channel 1.	
	Channel 2 (standard)		No	Yes	Select whether to use error/normal input for channel 2.	
	Channel 3 (expansion)		No	Yes	Select whether to use error/normal input for channel 3.	
	Channel 4 (expansion)		No	Yes	Select whether to use error/normal input for channel 4.	
	Channel 5 (expansion)		No	Yes	Select whether to use error/normal input for channel 5.	
	Channel 6 (expansion)		No	Yes	Select whether to use error/normal input for channel 6.	
SW09	1	Unused			Set to OFF	
	2	Unused			Set to OFF	

Set the dip switches for function selection according to the system to be used.

At factory default, all dip switches are set to OFF and the M-NET address is set to 01.

The settings of SW03-1 to 5 are common to expansion input/output channels 3 to 6.

Be sure to turn off the power before changing switch settings.

10 LED Display Designations

The LEDs of this device indicate the operation output status, operation input status, and error status of this device.

10-1. Operation Status Displays

Display Item		Display LED	Content	Condition																					
				Switch																					
				03-6	03-7																				
Power supply status	(1) Power supply to CPU	LED16 (CPU power on)	● : Lights when the CPU is energized. ☀ : Flashes during M-NET communication.	—	—																				
	(2) Power supply to M-NET circuit	LED17 (M-NET power on)	● : Lights when the M-NET is energized.	—	—																				
Input/output status	Ch1, 2	(1) Operation output status	LED05/04/03/02 (Output LEDs)	<table border="1"> <thead> <tr> <th rowspan="2">Output Method</th> <th colspan="2">Ch1</th> <th colspan="2">Ch2</th> </tr> <tr> <th>LED5</th> <th>LED4</th> <th>LED3</th> <th>LED2</th> </tr> </thead> <tbody> <tr> <td>Level Output</td> <td>● : ON ○ : OFF</td> <td>—</td> <td>● : ON ○ : OFF</td> <td>—</td> </tr> <tr> <td>Pulse Output</td> <td>● : ON</td> <td>● : OFF</td> <td>● : ON</td> <td>● : OFF</td> </tr> </tbody> </table> <p>* In the case of pulse output, the LED only lights during pulse output period.</p>	Output Method	Ch1		Ch2		LED5	LED4	LED3	LED2	Level Output	● : ON ○ : OFF	—	● : ON ○ : OFF	—	Pulse Output	● : ON	● : OFF	● : ON	● : OFF	—	—
		Output Method	Ch1			Ch2																			
	LED5		LED4	LED3	LED2																				
	Level Output	● : ON ○ : OFF	—	● : ON ○ : OFF	—																				
	Pulse Output	● : ON	● : OFF	● : ON	● : OFF																				
	(2) Operation/error input status	LED12/13/14/15 (Status display LEDs)	<table border="1"> <thead> <tr> <th rowspan="2">Input Method</th> <th>Ch1 Operation</th> <th>Ch2 Operation</th> <th>Ch1 Error</th> <th>Ch2 Error</th> </tr> <tr> <th>LED12</th> <th>LED13</th> <th>LED14</th> <th>LED15</th> </tr> </thead> <tbody> <tr> <td>Level Input</td> <td colspan="2">● : ON ○ : OFF</td> <td colspan="2">● : Error ○ : Normal</td> </tr> </tbody> </table> <p>* LED11 flashes each time a change in input is detected. (*1)</p>	Input Method	Ch1 Operation	Ch2 Operation	Ch1 Error	Ch2 Error	LED12	LED13	LED14	LED15	Level Input	● : ON ○ : OFF		● : Error ○ : Normal		OFF	OFF						
Input Method	Ch1 Operation	Ch2 Operation	Ch1 Error		Ch2 Error																				
	LED12	LED13	LED14	LED15																					
Level Input	● : ON ○ : OFF		● : Error ○ : Normal																						
Ch3-6	(1) Operation input status	LED12/13/14/15 (Status display LEDs)	<table border="1"> <thead> <tr> <th rowspan="2">Input Method</th> <th>Ch3</th> <th>Ch4</th> <th>Ch5</th> <th>Ch6</th> </tr> <tr> <th>LED12</th> <th>LED13</th> <th>LED14</th> <th>LED15</th> </tr> </thead> <tbody> <tr> <td>Level Input</td> <td colspan="4">● : ON ○ : OFF</td> </tr> </tbody> </table> <p>* LED11 flashes each time a change in input is detected. (*1)</p>	Input Method	Ch3	Ch4	Ch5	Ch6	LED12	LED13	LED14	LED15	Level Input	● : ON ○ : OFF				OFF	ON						
	Input Method	Ch3	Ch4		Ch5	Ch6																			
		LED12	LED13	LED14	LED15																				
Level Input	● : ON ○ : OFF																								
(2) Operation output status	LED12/13/14/15 (Status display LEDs)	<table border="1"> <thead> <tr> <th rowspan="2">Output Method</th> <th>Ch3</th> <th>Ch4</th> <th>Ch5</th> <th>Ch6</th> </tr> <tr> <th>LED12</th> <th>LED13</th> <th>LED14</th> <th>LED15</th> </tr> </thead> <tbody> <tr> <td>Level/Pulse Output</td> <td colspan="4">● : ON ○ : OFF</td> </tr> </tbody> </table> <p>* LED11 flashes each time a change in input is detected. (*1) * In the case of pulse output, the LED only lights during pulse output period.</p>	Output Method	Ch3	Ch4	Ch5	Ch6	LED12	LED13	LED14	LED15	Level/Pulse Output	● : ON ○ : OFF				ON	OFF							
Output Method	Ch3	Ch4		Ch5	Ch6																				
	LED12	LED13	LED14	LED15																					
Level/Pulse Output	● : ON ○ : OFF																								
(3) Error input status	LED12/13/14/15 (Status display LEDs)	<table border="1"> <thead> <tr> <th rowspan="2">Input Method</th> <th>Ch3</th> <th>Ch4</th> <th>Ch5</th> <th>Ch6</th> </tr> <tr> <th>LED12</th> <th>LED13</th> <th>LED14</th> <th>LED15</th> </tr> </thead> <tbody> <tr> <td>Level Input</td> <td colspan="4">● : Error ○ : Normal</td> </tr> </tbody> </table> <p>* LED11 flashes each time a change in input is detected. (*1)</p>	Input Method	Ch3	Ch4	Ch5	Ch6	LED12	LED13	LED14	LED15	Level Input	● : Error ○ : Normal				ON	ON							
Input Method	Ch3	Ch4		Ch5	Ch6																				
	LED12	LED13	LED14	LED15																					
Level Input	● : Error ○ : Normal																								
Communication error status (*2)	(1) 4-digit error code	LED12/13/14/15 (Status display LEDs)	Refer to "10-2. Communication Error Displays".	When a communication error occurs																					

*1: If LED11 flashes quickly three times in any of the display states, it is an indication that an error input has been detected on one of channels 3 to 6. To confirm the details, turn ON both of SW03-6 and 7 and select to "(3) Error Input Status Display of Channels 3 to 6".

*2: If a communication error occurs in any of the display states, switch to "Communication Error Displays". Changing SW03-8 from ON to OFF masks the "Communication Error Displays" for 10 seconds so that the input/output status display set with SW03-6 and 7 can be confirmed.

10-2. Communication Error Displays

If a communication error occurs, a 4-digit error code will be repeatedly displayed according to the steps shown below. "Communication Error Displays" consist of the following 10 steps. This operation is performed repeatedly to indicate the 4-digit error code for the communication error.

Furthermore, changing SW03-8 from ON to OFF masks the "Communication Error Displays" for 10 seconds so that the input/output status set with SW03-6 and 7 can be displayed.

Note ●:On, ○:Off, ✨:Flashing

	LED11	LED12	LED13	LED14	LED15	Function	Remark
	Common	Error cord display (Binary number indication)					
		$2^3=8$	$2^2=4$	$2^1=2$	$2^0=1$		
STEP1	○	✨	✨	✨	✨	"Communication Error Displays" Starting Point Indication	LEDs 12 to 15 flash 3 times
STEP2	○	○	○	○	○	Blank	Turn Off
STEP3	●	●/○	●/○	●/○	●/○	Error code 1000's digit	Error code 1000's digit indication In the case of 6, ○●●○
STEP4	○	○	○	○	○	Blank	Turn Off
STEP5	●	●/○	●/○	●/○	●/○	Error code 100's digit	Error code 100's digit indication In the case of 6, ○●●○
STEP6	○	○	○	○	○	Blank	Turn Off
STEP7	●	●/○	●/○	●/○	●/○	Error code 10's digit	Error code 10's digit indication In the case of 0, ○○○○
STEP8	○	○	○	○	○	Blank	Turn Off
STEP9	●	●/○	●/○	●/○	●/○	Error code 1's digit	Error code 1's digit indication In the case of 7, ○●●●
STEP10	○	○	○	○	○	Blank	Turn Off

The error codes that are displayed for M-NET communication errors are as shown below.

Error Code	Description of Error
6600	Multiple address error
6601	M-NET polarity unset error
6602	Transmission processor hardware error
6603	Transmission circuit bus-busy error
6606	Communications with transmission processor error
6607	No ACK error
6608	No return of response frame

11 System Operation Test

Use the following procedure to confirm operation of the system.

- (1) Configure the settings of this device and the system controllers while referring to "8. Initial Settings".
- (2) Perform an operation from a system controller and confirm whether a connected general-purpose device can be operated normally.
- (3) In the case of using contact inputs
 - (a) Change the operate/stop status of the connected device and confirm whether the operation status is displayed on the system controller.
 - (b) Generate an error on the connected general-purpose device and confirm whether the error is displayed on the system controller.
- (4) In the case of using error interlock stop outputs
 - (a) Generate an error on the connected device and confirm that "Stop" is output from a contact output.

If there is a problem, check the wiring and settings.

For details on configuring settings, refer to "8. Initial Settings" and "9. Dip Switch Functions".

This product is designed and intended for use in the residential, commercial and light-industrial environment.

This product at hand is based on the following EU regulations:

- Low Voltage Directive 2006/95/EC
- Electromagnetic Compatibility Directive 2004/108/EC

NOTE:

This equipment has been tested and found to comply with the limits for a Class B digital device, pursuant to Part 15 of the FCC Rules. These limits are designed to provide reasonable protection against harmful interference in a residential installation. This equipment generates, uses and can radiate radio frequency energy and, if not installed and used in accordance with the instructions, may cause harmful interference to radio communications.

However, there is no guarantee that interference will not occur in a particular installation.

If this equipment does cause harmful interference to radio or television reception, which can be determined by turning the equipment off and on, the user is encouraged to try to correct the interference by one or more of the following measures:

- Reorient or relocate the receiving antenna.
- Increase the separation between the equipment and receiver.
- Connect the equipment into an outlet on a circuit different from that to which the receiver is connected.
- Consult the dealer or an experienced radio/TV technician for help.