

Mitsubishi Electric Air Conditioner CITY MULTI CMY-Q100CBK2



Twinning Kit Installation Manual

WT07821X01

- For your safety, thoroughly read the following instructions prior to installation.

Safety Precautions

- Thoroughly read the following "Safety Precautions" to ensure proper installation.
- Observe the following important safety precautions at all times.
- Hazards that can occur from incorrect handling are classified by the symbols below:

 WARNING	Incorrect handling can result in death or serious injury.
 CAUTION	Incorrect handling can result in bodily injury and/or structure damage.

WARNING

Only a dealer or qualified technician should perform installation.

- Improper installation may result in refrigerant gas leakage and equipment damage.

Do not make any modifications or alterations. Consult your dealer for repair.

- Improper installation may result in water leakage, electric shock, or fire.

In the event of a refrigerant leak, thoroughly ventilate the room.

- If refrigerant leaks and comes in contact with an open flame, toxic gases will be generated.

Properly install all parts according to the instructions in the Installation Manual.

- If the wrong twinning pipe or wrong size connecting pipe is used, air conditioning performance will suffer.

When installing or relocating the unit, check that no substance other than the specified refrigerant (R410A) enters the refrigerant circuit.

- Any presence of foreign substance or air can cause abnormal pressure rise or explosion.

After installation, check for a refrigerant leak.

- If leaked refrigerant comes in contact with a heat source, such as a fan heater, stove, or electric grill, toxic gases will be generated.

CAUTION

Properly dispose of packing materials.

- Plastic bags can pose suffocation and choking hazards: keep them out of the reach of children. Tear the plastics bags before disposing of them.

Do not touch the refrigerant pipes and refrigerant circuit components with bare hands during and immediately after operation.

- During or immediately after operation, certain parts of the unit such as pipes and compressor may be either very cold or hot, depending on the state of the refrigerant in the unit at the time. To reduce the risk of frostbites and burns, do not touch these parts with bare hands.

*** See the Installation Manual that came with the outdoor unit for installation instructions.**

1. Confirming the Package Contents

The following items are included with the Twinning Kit (CMY-Q100CBK2). Verify that all items are present before starting installation.

* Always use the twinning pipes included in the kit when preparing the twinning kit.

If the field-supplied pipes do not fit the parts in the kit, use the accessory piping parts listed below.

<1> Package contents

Model	① Low-pressure twinning kit	② High-pressure twinning pipe	③ Fixing screw	④ Elbow pipe $\varnothing 22.2$ [7/8]	⑤ Elbow pipe $\varnothing 28.58$ [1-1/8]	⑥ High-pressure pipe	⑦ Pipe cover (Length: 150 mm)	⑧ Pipe cover (Length: 60 mm)
CMY-Q100CBK2	1	1	1	1	1	1	2	1

Model	⑨ Pipe cover (Length: 80 mm)	⑩ OD28.58[1-1/8] -ID34.93 [1-3/8]	⑪ Installation Manual (this booklet)	⑫ Insulation cover	⑬ Cable tie	⑭ Water stopper	⑮ Sealing material (Small)	⑯ Sealing material (Large)
CMY-Q100CBK2	2	1	1	1	2	1	1	1

<2> List of field-supplied parts

- Refrigerant pipes other than the ones provided in the kit.
- Heat-resistant insulation material (for field-supplied refrigerant pipes)
- Insulation cover tape

2. Selecting the Correct Size Refrigerant Pipes and Using the Twinning Kit

<1> Pipe size

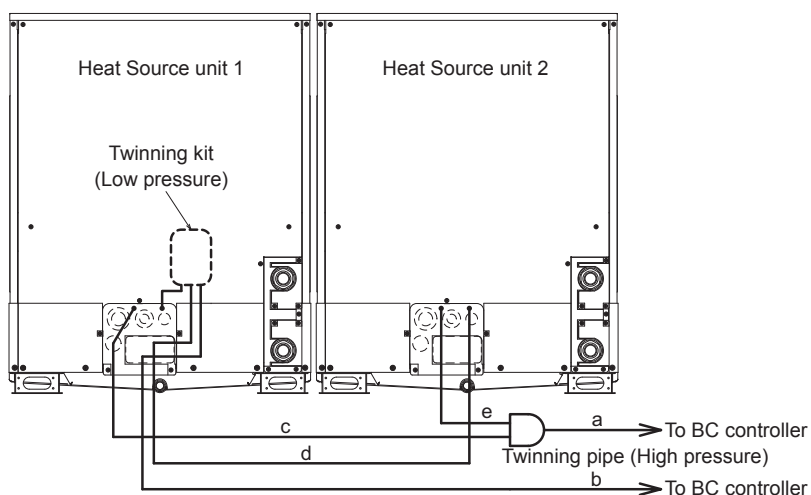

- (1) Field-supply the pipes to be connected to the kit.
- (2) Select the correct size pipe referring to the outline diagram of the unit model in use or the Databook.
- (3) If the pipe was cut with a pipe cutter, remove the burrs and eliminate foreign materials before connecting.

* On the low-pressure side, the twinning kit connects to the field-supplied pipes inside the heat source unit.

The distributor on the low-pressure side must be placed in the heat source unit that has a larger capacity index of the two, regardless of the relative positions of the heat source units or their addresses.

If the distributor is placed in the heat source unit that has a smaller capacity, refrigerant will not be properly distributed and compressor failure may result.

(If heat source units that have the same capacity are used in combination, the distributor can be placed in either heat source unit.)

<2> Connecting the twinning pipe kit

- (1) Braze the high-pressure pipe (⑥) to the refrigerant service valve.

*3: Use the pipe joint (field supply) only PQRY-P144 (P72 + P72) unit and connect to the pipe (⑥).

- (2) Screw down the low-pressure twinning pipe kit (①) to the sheet metal of the refrigerant service valve with the screw (③), and braze it to the refrigerant service valve.

- (3) Braze the elbow (⑤) to the low-pressure twinning pipe kit (①) first, and then braze it to the pipe (⑩)*1 and the field-piping (Low-pressure connecting pipe: To heat source unit).*2

- *1: Pipe (10) is used only for the PQRV-P240 (P120 + P120) unit.
- *2: The field piping diameter is as follows.
In the case of PQRV-P144 (P72 + P72), P168 (P96 + P72), P192 (P96 + P96), P216 (P120 + P96): $\varnothing 28.58$ [1-1/8]
In the case of PQRV-P240 (P120 + P120): $\varnothing 34.93$ [1-3/8]

(4) Braze the elbow (4) to the low-pressure pipe in the right.

- *4: Use the pipe joint (field supply) only PQRV-P144 (P72 + P72) unit and connect to the elbow (4).

Note

1. Exercise caution not to burn the cables while brazing the pipes.
2. Before brazing pipes to the refrigerant service valve, place a wet towel on the valve to keep its temperature from rising above 120°C [248°F].

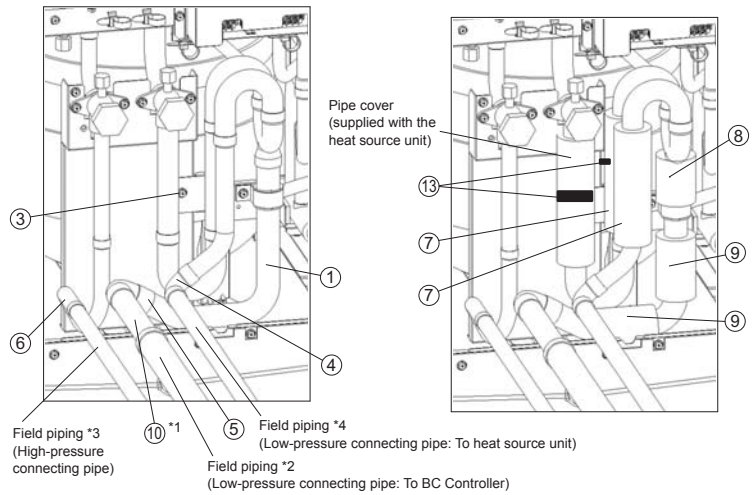

(5) Attach the pipe cover (in the accessory kit of the heat source unit) and the five pipe covers (7, 8, and 9) to the pipes as shown in the figure. Then, fix the pipe covers at two places with the cable ties (13) as shown in the figure.

CAUTION

- To prevent the refrigerant service valve from being damaged, do not let its temperature rise above 120°C [248°F]. Place a wet towel on the refrigerant service valve before brazing the pipes.
- Direct the blazing torch flame away from the adjacent cables and sheet metal to keep them from being damaged.

(6) Pipe connection (high-pressure side)

- Make sure the pipes from the twinning pipe to the heat source unit are sloped downwards.

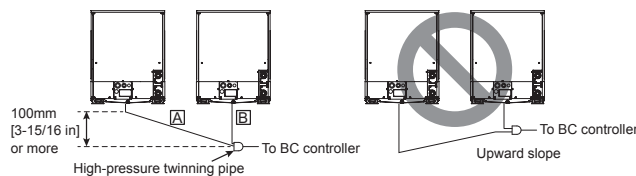

Total pipe length = A + B < 5m [16-7/16 ft]

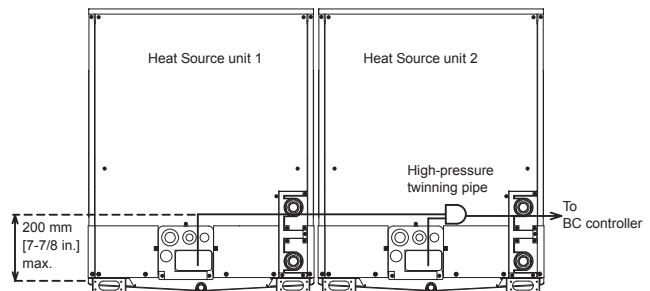

- If high-pressure twinning pipe is installed above the base of the heat source unit, it should be no more than 200 mm [7-7/8 in.].

3. Pipe Connection Example

Connect the pipes between heat source units, referencing the figure.

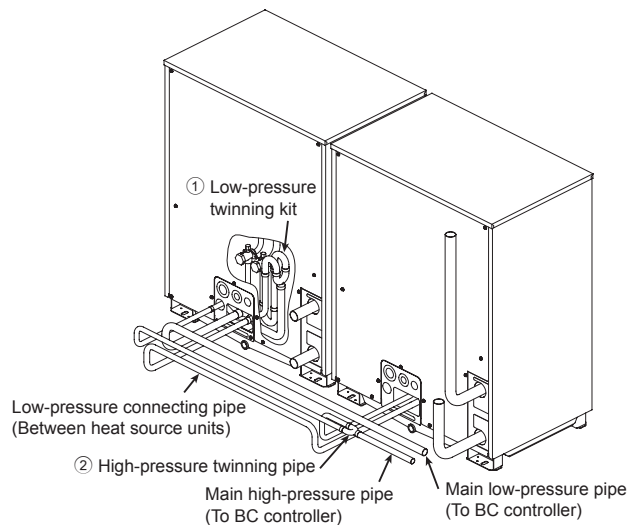

4. Insulation Cover Installation

Install the insulation cover on the twinning kit after brazing the pipes and twinning kit.

Insulate all refrigerant pipes. Insulate the high-pressure and low-pressure pipes separately, and pipes located inside the unit as well as the outside. Use heat-resistant insulation material (Heat resistant : at least 120°C [248°F], Thickness: high-pressure = 10 mm [13/32 in.], low-pressure = 20 mm [13/16 in.]). Position the edges of the insulation cover and heat-resistant insulation material so as not to leave a gap, and then wrap the exterior perimeter of the pipe joints and middle with tape (field-supplied).

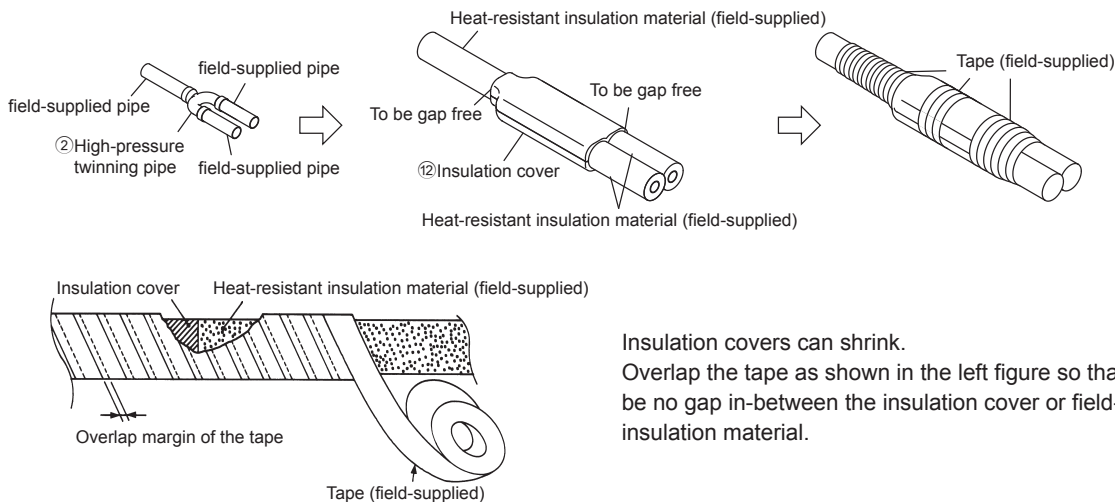

Insulation covers can shrink.

Overlap the tape as shown in the left figure so that there will be no gap in-between the insulation cover or field-installed insulation material.

5. Installing the water stopper

Make sure to install the supplied water stopper and sealing material when providing insulation.

The water stopper supplied with this kit is for the main low-pressure pipe. For the low-pressure pipe between heat source units, use the water stopper and the sealing material that are supplied with the unit.

Regarding the wrapping, be careful of wrapping low-pressure side as well as high-pressure side.

- Wrap the sealing material (15) around the end of the elbow.

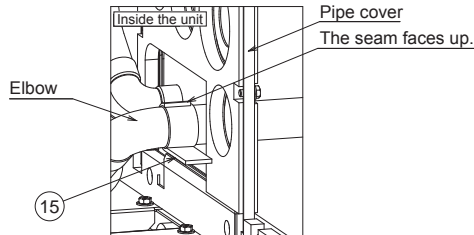

- Pull the field-installed insulation forward to the edge of the sealing material that was used in step (1).

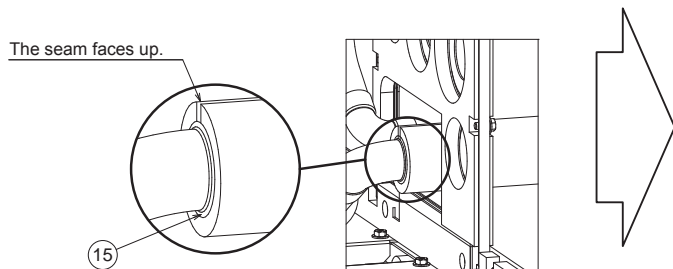

- Install the water stopper (14) on the insulation edge. Wrap the sealing material (16) around the field-installed insulation.

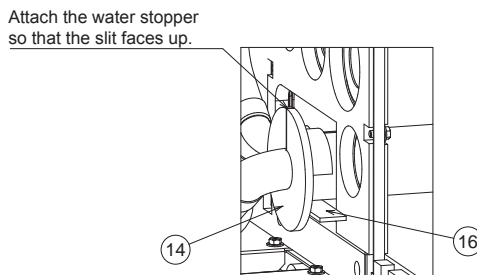

6. Miscellaneous Notes

Secure the field-supplied pipes with a pipe cover and a cable tie in place to keep them from coming in contact with other pipes as necessary.

Install the insulation cover so that the edges of the cover meet at the top.

Install the flame retardant insulation as field supplied.