

# WIND SCREEN INSTALLATION PUY-A42NHA

## Front and Side Wind Screen Installation

Parts model #:

- A) PE-FR-24-36 (front 2x)
- B) PE-RE-42 (rear 1x)
- C) PE-SD-42 (side 1x)
- D) FR-Blk-24-36 (front 2x)
- E) SD-RE-Blk (side/rear 2x)

**C)** Align Side wind screen with existing screw holes and secure with screws provided. The Side wind screen does not have to be used when the unit is installed against a wall or object that will function as an adequate wind screen. Ensure safety cables provided are secured to unit properly.

**E)** Wind blockers are universal to fit both Left and Right sides of Rear and Side wind screens. Depending on unit installation blockers are used to prevent wind from blowing directly into the heat exchanger. Secure blockers to wind screen using pre-drilled holes and screws provided.

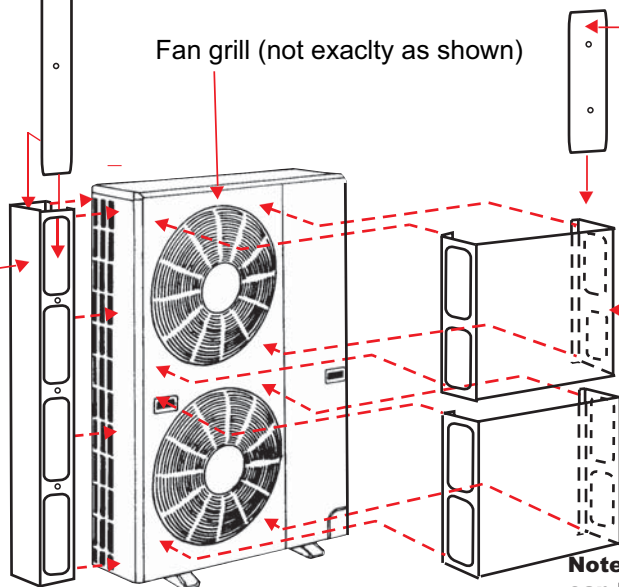

**D)** Wind blockers are universal to fit both Left and Right sides of Front wind screens. Depending on unit installation blockers are used to prevent wind from blowing directly into the heat exchanger. Secure blockers to wind screen using pre drilled holes and screws provided.

**A)** Remove four screws and release fan grill. Align fan grill with the four holes of wind screen and attach with screws previously removed. Ensure safety cables provided are secured to unit properly.

**Note:** Do not drill into the unit cover as damage can be caused to the heat exchange coil that can cause refrigerant leaks. Use the existing holes for this purpose.

## Rear Wind Screen Installation

**E)** Wind blockers are universal to fit both Left and Right sides of Rear and Side wind screens. Depending on unit installation blockers are used to prevent wind from blowing directly into the heat exchanger. Secure blockers to wind screen using pre-drilled holes and screws provided.

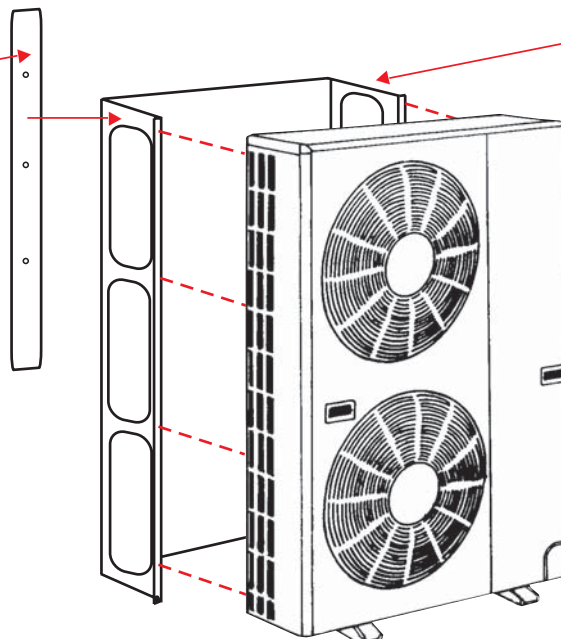

**B)** Align Rear wind screen with existing screw holes and secure with screws provided. The Rear wind screen does not have to be used when the unit is installed against a wall or object that will function as an adequate wind screen. Ensure safety cables provided are secured to unit properly.

**Note:** Do not drill into the unit cover as damage can be caused to the heat exchange coil that can cause refrigerant leaks. Use the existing holes for this purpose.