

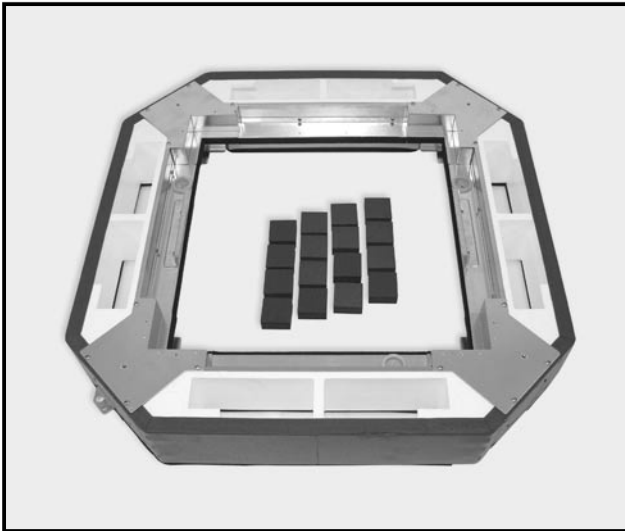

Photo



Descriptions

A part required for installation of a high-efficiency filter element. Can also be used for introducing fresh air from the outside.

Applicable Models

■ PLA-A** AA

Specifications

TO BE CONFIRMED

Outline and Dimensions

Unit : mm

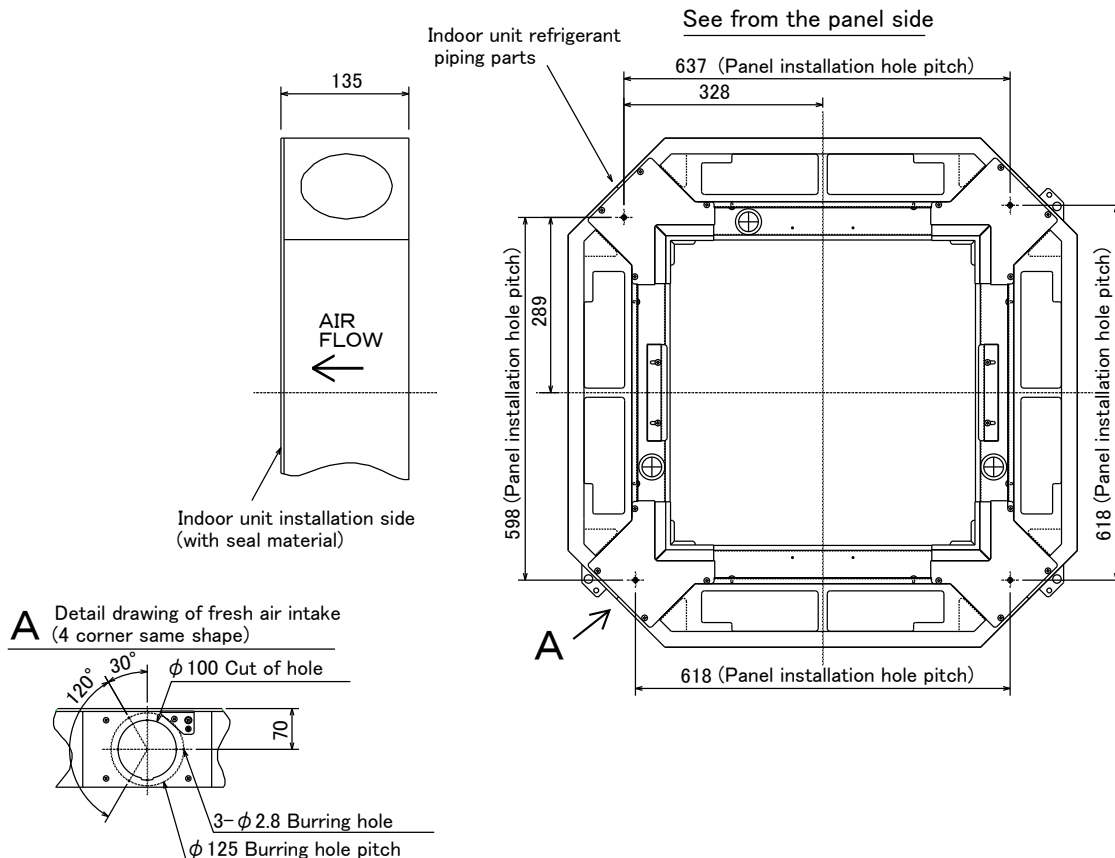

How to Use / How to Install

Optional Parts Installation Manual of MULTI-FUNCTIONAL CASEMENT AND HIGH-EFFICIENCY FILTER ELEMENT

This manual is written for both the Multi-functional casement and the High-efficiency filter element in common. Follow the instruction described in this manual in accordance with the option parts.

Model
PAC-SG03TM-E (Multi-functional casement)
PAC-SG01KF-E (High-efficiency filter element)

1 Parts check. (The unit is provided with this manual and following parts in the box.)

MULTI-FUNCTIONAL CASEMENT

Part #, Name	① Multi-functional casement	② Screw with washer (black)	③ Flat head screw (gold)	④ Bracket A	⑤ Bracket B	⑥ Bracket C	⑦ Air outlet block
Q'ty	1	5 M5×0.8×15	2 M5x0.8 with stepped body	2	1	1	16
Figure							

HIGH-EFFICIENCY FILTER ELEMENT

Part #, Name	⑧ High-efficiency filter element
Q'ty	1
Figure	

NOTICE

- In case that the High-efficiency filter element ⑧ is installed, it should be installed on the Multi-functional casement ① which is option. Be sure to purchase the Multi-functional casement.
- If it is necessary of fresh-air intake, the Duct flange and the Duct are necessary as well as the Multi-functional casement ①. Be sure to prepare these items locally. The recommended shape for the Duct flange is described in the page 3. ※It is available of fresh-air intake even when the High-efficiency filter element ⑧ is installed.
- Follow the procedure in this manual for installation of the Multi-functional casement ①. Otherwise, it is possible that installation of refrigerant tubes, drain tubes, and electrical wiring will not be available.

2 Installation of Indoor unit.

- Follow the description in the installation manual which is attached to the indoor unit.

3 Installation of Multi-functional casement.

Preparation before installation

- If it is necessary to change the number of air outlet, the optional parts Air Outlet Shutter Plate should be installed on the indoor unit. Therefore, the installation should be done before the Multi-functional casement ① is installed on the indoor unit.
- The Multi-functional casement ① has four knockout on each side so that the air can be taken from any of four sides. Select any one or two sides in advance and make knockout holes on the Multi-functional casement ①.

— Knockout hole position for fresh-air intake. —

— Making knockout holes —

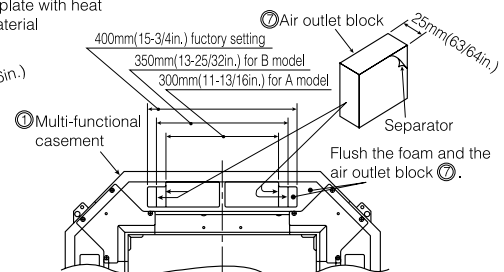
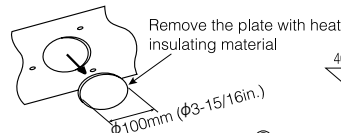
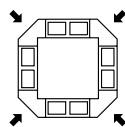

- In case that the type of indoor unit is "3type/80type/12,18type", attach the outlet block ⑦ to the outlet of the Multi-functional casement ① as shown in the right drawing. Be sure to attach it to right and left equally.

Model	Indoor unit type	No. of air outlet block ⑦ per air outlet
A	12type	4 pcs (total 16)
B	3type / 80type / 18type	2 pcs (total 8)

Caution Air outlet block should be attached securely.

- If the air outlet block is not attached securely, it can cause the problem that air flow will not be sufficient, or the unit will not operate properly by means of dew which can be caused.

3 Installation of Multi-functional casement. Continued

- Loosen the three lock screws which fix drain pan on the indoor unit.
Put the Bracket A ④ and the Bracket B ⑤ to the lock screw and tighten the lock screw together with these brackets at the location as shown in the right drawing. Then remove one drain pan lock screw of the refrigerant tube corner position and fix the Bracket C ⑥ with the drain pan lock screw and the Screw with washer (black) ②.

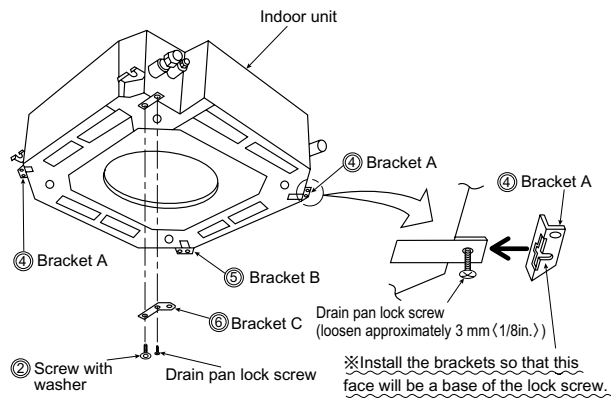

Hand tightening

- Fix the two flat head screw (gold) ③ to each position (drain tube corner position and to its opposite angle). See right figure.
- Hook the hole of the Multi-functional casement ① to the flat head screw (gold) the screw ③ and hand tight.

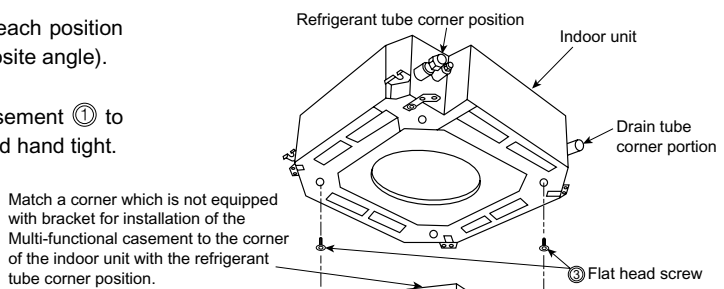

Fixing

- Remove the bracket for installation of grille of the Multi-functional casement ① for refrigerant tube corner position. (four screws)
- Hand tighten the Screw with washer (black) ② to four holes of the Multi-functional casement ①. Confirm the position of the Multi-functional casement ①, then tighten the Screw with washer (black) ② securely.

Bracket for installation of the Multi-functional casement (at three corners)

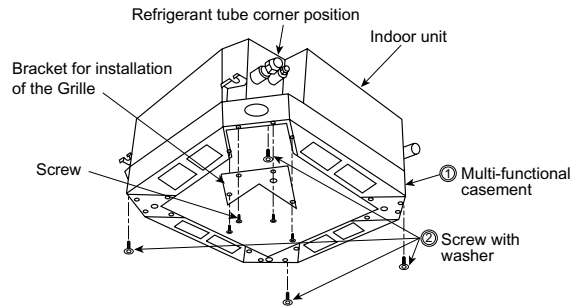

Caution	Screw with washer at four position.
	● If the unit is fixed without hand tightening, the screws can be broken and it can cause air leakage.

- Install the bracket for installation of grille which was removed at. (four screws)

Height adjustment

※It is recommended to make this adjustment before installation of duct when fresh air intake.

- Readjust the height of the Multi-functional casement ① with the gauge which is attached to the grille as show right.

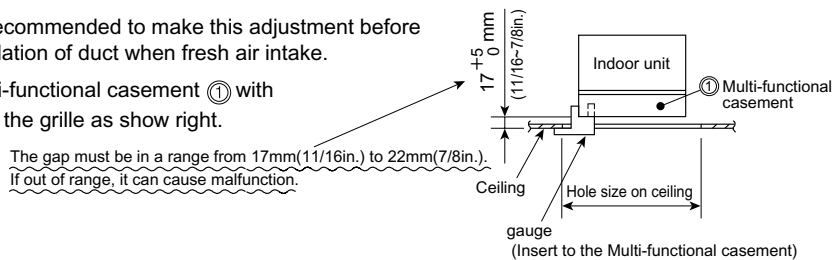

4 Installation of duct (in case of fresh air intake)

 Caution	Linkage of duct fan and air conditioner
	<ul style="list-style-type: none"> ● In case that a duct fan is used, be sure to make it linked with the air conditioner when outside air is taken. Do not run the duct fan only. It can cause dew drop.

Making a duct flange (prepared locally)

- The shape of duct flange shown right is recommended.

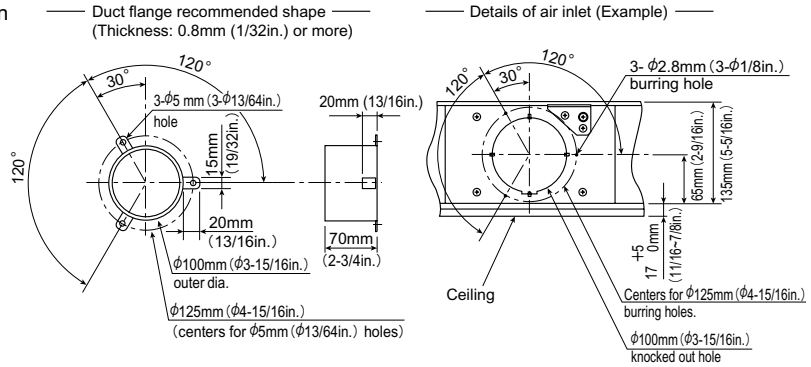

Installation of duct flange

- Install a duct flange to each knock out hole of the Multi-functional casement ① with three 4x10 tapping screws which should be prepared locally.

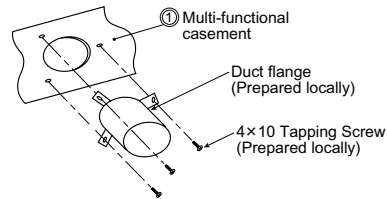

Installation of duct (should be prepared locally)

- Prepare a duct of which inner diameter fits into the outer diameter of the duct flange.
- In case that the environment above the ceiling is high temperature and high humidity, wrap the duct in a heat insulator to avoid causing dew drop on the wall.

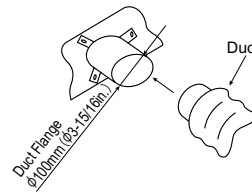

5 Installation of grille

- Installation should be done in accordance with the manual which is attached to the grille.

When the electrical cover of the indoor unit is removed, be sure to remove one of the brackets (two screws) of the Multi-functional casement ① first as shown right.

Each lead wire for the grille should be run through the bushing of the Multi-functional casement as shown below, and be connected to the indoor unit.

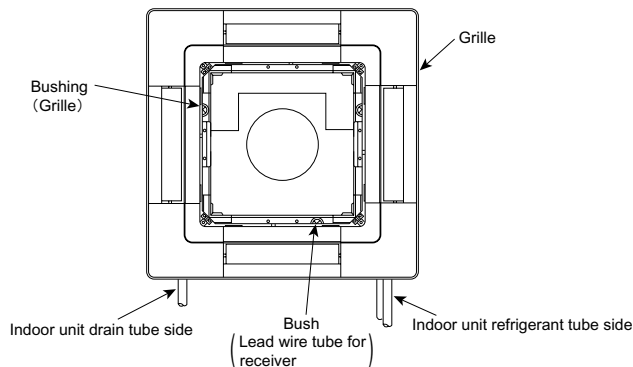
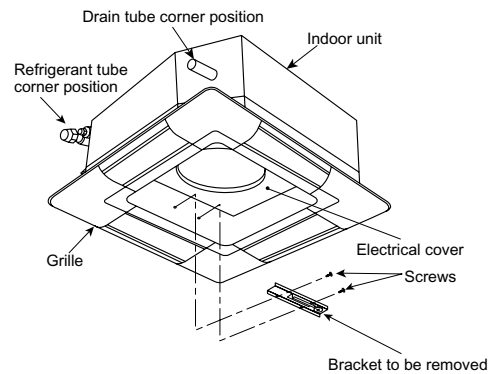

6 Installation of High-efficiency filter element (same procedure for replacement)

- Remove the intake grille of the grille in advance.
- Loosen the four screws of bracket for installation of the High-efficiency filter element of the Multi-functional casement ① as shown right. Then, slide them outside.
- Make sure of the air flow direction with the label put on the side of the High-efficiency filter element. Set it to the Multi-functional casement ①, and slide back the bracket for installation of the High-efficiency filter element to the original position, then fix it with screws.
- ※ When the indoor unit is used with "2 ways" air outlet, the High-efficiency filter element is not available.
- ※ When the High-efficiency filter element is installed, the operation noise can be larger.

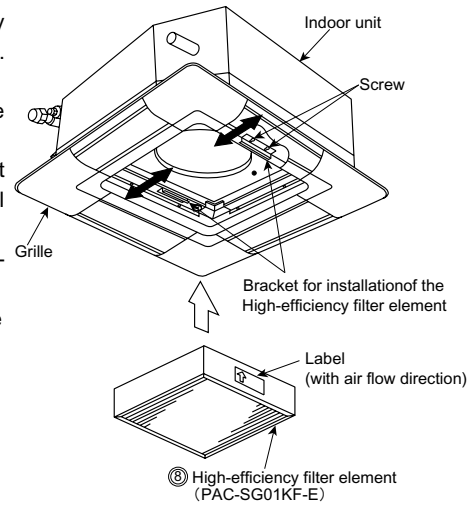

7 Air flow volume setting when High-efficiency filter element is installed

※ In case that High-efficiency filter element is installed, it is necessary to set up the air flow volume.

Caution	Set up for increasing air flow volume
	● If the set up is not done correctly, the air flow volume will decrease and it can lower the performance and cause dew drop.

- 1) In case that the combination indoor unit is AK type:
 - Set the DIP switch "SW8" on the Indoor controller board of the indoor unit to ON.

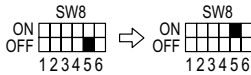

- 2) In case that the combination indoor unit is VAM type:
 - Set the switch SWC on the address board in the indoor unit to 『オフ』 . (The factory default setting is 『標』)

〔 『オフ』 = OPTION 『標』 = STANDARD 〕

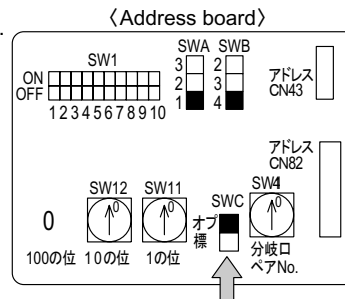

- 3) In case that the combination indoor unit is AA type:
 - Set up the remote controller. Refer to the chapter "Electrical work" in the installation manual for the indoor unit.