

SERVICE MANUAL

Series PCA Ceiling Suspended R410A

Indoor unit [Model names]	[Service Ref.]
PCA-A24GA	PCA-A24GA PCA-A24GA ₁ PCA-A24GA ₂
PCA-A30GA	PCA-A30GA PCA-A30GA ₁ PCA-A30GA ₂
PCA-A36GA	PCA-A36GA PCA-A36GA ₁ PCA-A36GA ₂
PCA-A42GA	PCA-A42GA PCA-A42GA ₁ PCA-A42GA ₂

Revision:

- PCA-A24/30/36/42GA₂ are added in REVISED EDITION-C.
- Some descriptions have been modified.

- Please void OC368 REVISED EDITION-B.

NOTE:

- This manual describes only service data of the indoor units.
- RoHS compliant products have <G> mark on the spec name plate.
- For servicing RoHS compliant products, refer to the RoHS PARTS LIST.

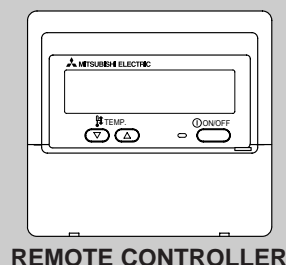
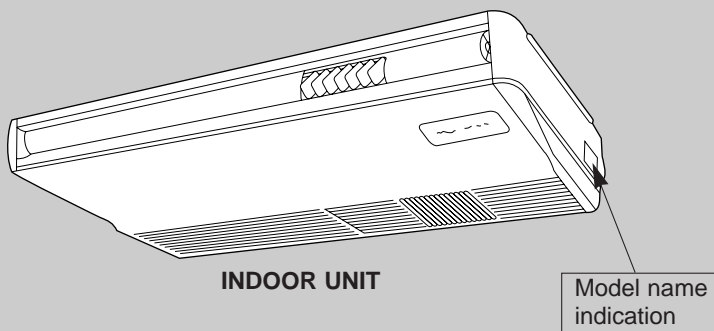

CONTENTS

1. TECHNICAL CHANGES	2
2. REFERENCE MANUAL	2
3. SAFETY PRECAUTION	3
4. PART NAMES AND FUNCTIONS	5
5. SPECIFICATIONS	8
6. NOISE CRITERION CURVES	9
7. OUTLINES AND DIMENSIONS	10
8. WIRING DIAGRAM.....	12
9. REFRIGERANT SYSTEM DIAGRAM	14
10. TROUBLESHOOTING	15
11. SPECIAL FUNCTION	26
12. DISASSEMBLY PROCEDURE	29
13. PARTS LIST	34
14. RoHS PARTS LIST	37

1**TECHNICAL CHANGES****PCA-A24GA₁ → PCA-A24GA₂****PCA-A30GA₁ → PCA-A30GA₂****PCA-A36GA₁ → PCA-A36GA₂****PCA-A42GA₁ → PCA-A42GA₂**

- Indoor controller board(I.B) has been changed(11.SPECIAL FUNCTION is added).

PCA-A24GA → PCA-A24GA₁**PCA-A30GA → PCA-A30GA₁****PCA-A36GA → PCA-A36GA₁****PCA-A42GA → PCA-A42GA₁**

- Indoor controller board(I.B) has been changed.

2**REFERENCE MANUAL****2-1. OUTDOOR UNIT SERVICE MANUAL**

Service Ref.	Service Manual No.
PUZ-A18/24/30/36/42NHA PUZ-A18/24/30/36/42NHA-BS PUY-A12/18/24/30/36/42NHA ⁽¹⁾ PUY-A12/18/24/30/36/42NHA ⁽¹⁾ -BS	OC367

2-2. TECHNICAL DATA BOOK

Series (Outdoor unit)	Data Book No.
PUZ-A·NHA PUZ-A·NHA-BS PUY-A·NHA PUY-A·NHA-BS	OCS04

3-1. ALWAYS OBSERVE FOR SAFETY

Before obtaining access to terminals, all supply circuits must be disconnected.

3-2. CAUTIONS RELATED TO NEW REFRIGERANT

Caution for units utilising refrigerant R410A

Use new refrigerant pipes.

Make sure that the inside and outside of refrigerant piping is clean and it has no contamination such as sulfur hazardous for use, oxides, dirt, shaving particles, etc. In addition, use pipes with specified thickness.

Contamination inside refrigerant piping can cause deterioration of refrigerant oil etc.

Store the piping to be used during installation indoors and keep both ends of the piping sealed until just before brazing. (Leave elbow joints, etc. in their packaging.)

If dirt, dust or moisture enters into refrigerant cycle, that can cause deterioration of refrigerant oil or malfunction of compressor.

Use ester oil, ether oil or alkylbenzene oil (small amount) as the refrigerant oil applied to flares and flange connections.

If large amount of mineral oil enters, that can cause deterioration of refrigerant oil etc.

Charge refrigerant from liquid phase of gas cylinder.

If the refrigerant is charged from gas phase, composition change may occur in refrigerant and the efficiency will be lowered.

Do not use refrigerant other than R410A.

If other refrigerant (R22 etc.) is used, chlorine in refrigerant can cause deterioration of refrigerant oil etc.

Use a vacuum pump with a reverse flow check valve.

Vacuum pump oil may flow back into refrigerant cycle and that can cause deterioration of refrigerant oil etc.

Use the following tools specifically designed for use with R410A refrigerant.

The following tools are necessary to use R410A refrigerant.

Tools for R410A	
Gauge manifold	Flare tool
Charge hose	Size adjustment gauge
Gas leak detector	Vacuum pump adaptor
Torque wrench	Electronic refrigerant charging scale

Keep the tools with care.

If dirt, dust or moisture enters into refrigerant cycle, that can cause deterioration of the refrigerant oil or malfunction of the compressor.

Do not use a charging cylinder.

If a charging cylinder is used, the composition of refrigerant will change and the efficiency will be lowered.

Ventilate the room if refrigerant leaks during operation. If refrigerant comes into contact with a flame, poisonous gases will be released.

[1] Cautions for service

- (1) Perform service after recovering the refrigerant left in a unit completely.
- (2) Do not release refrigerant in the air.
- (3) After completing service, charge the cycle with specified amount of refrigerant.
- (4) When performing service, install a filter drier simultaneously.
Be sure to use a filter drier for new refrigerant.

[2] Additional refrigerant charge

When charging directly from cylinder

- Check that cylinder for R410A on the market is syphon type.
- Charging should be performed with the cylinder of syphon stood vertically. (Refrigerant is charged from liquid phase.)

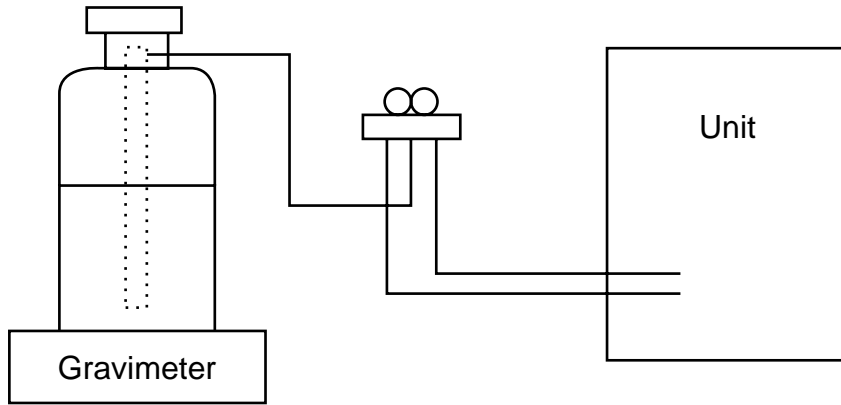

[3] Service tools

Use the below service tools as exclusive tools for R410A refrigerant.

No.	Tool name	Specifications
①	Gauge manifold	<ul style="list-style-type: none"> ·Only for R410A ·Use the existing fitting specifications. (UNF1/2) ·Use high-tension side pressure of 5.3MPa-G or over.
②	Charge hose	<ul style="list-style-type: none"> ·Only for R410A ·Use pressure performance of 5.09MPa-G or over.
③	Electronic scale	—
④	Gas leak detector	·Use the detector for R134a, R407C or R410A.
⑤	Adaptor for reverse flow check	·Attach on vacuum pump.
⑥	Refrigerant charge base	—
⑦	Refrigerant cylinder	<ul style="list-style-type: none"> ·Only for R410A ·Top of cylinder (Pink) ·Cylinder with syphon
⑧	Refrigerant recovery equipment	—

4

PART NAMES AND FUNCTIONS

● Indoor Unit

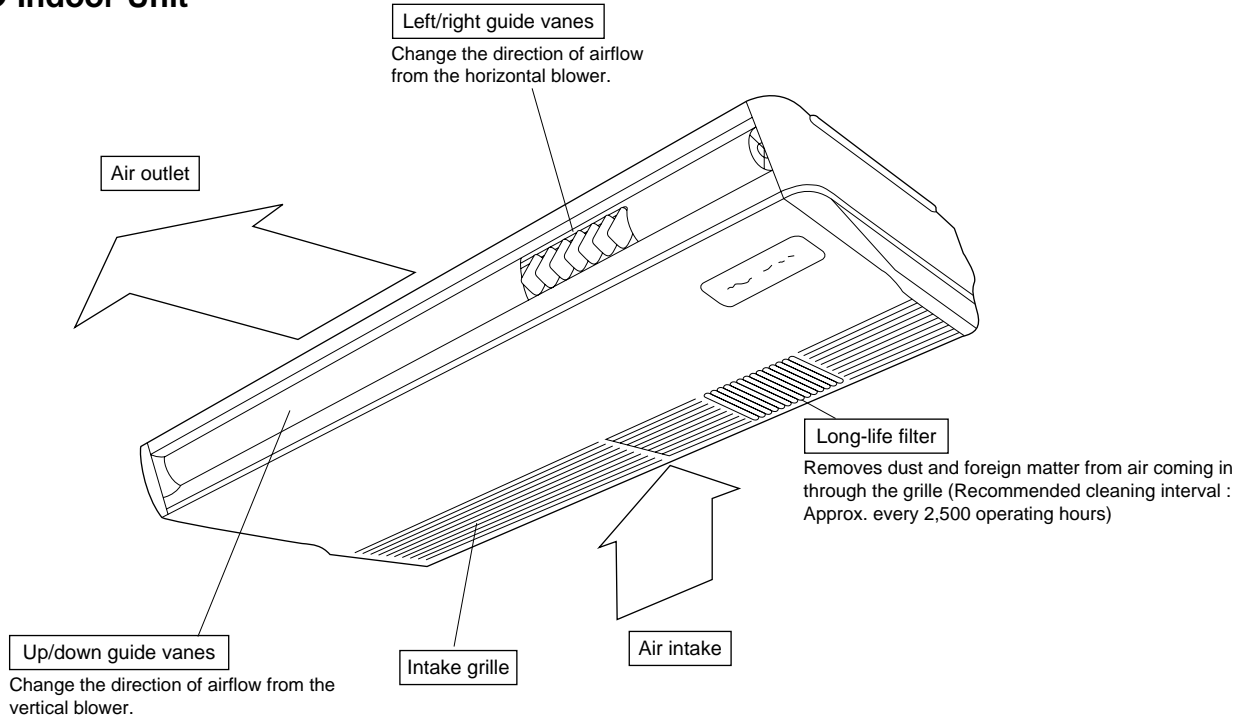

● Wired remote controller

Once the controllers are set, the same operation mode can be repeated by simply pressing the ON/OFF button.

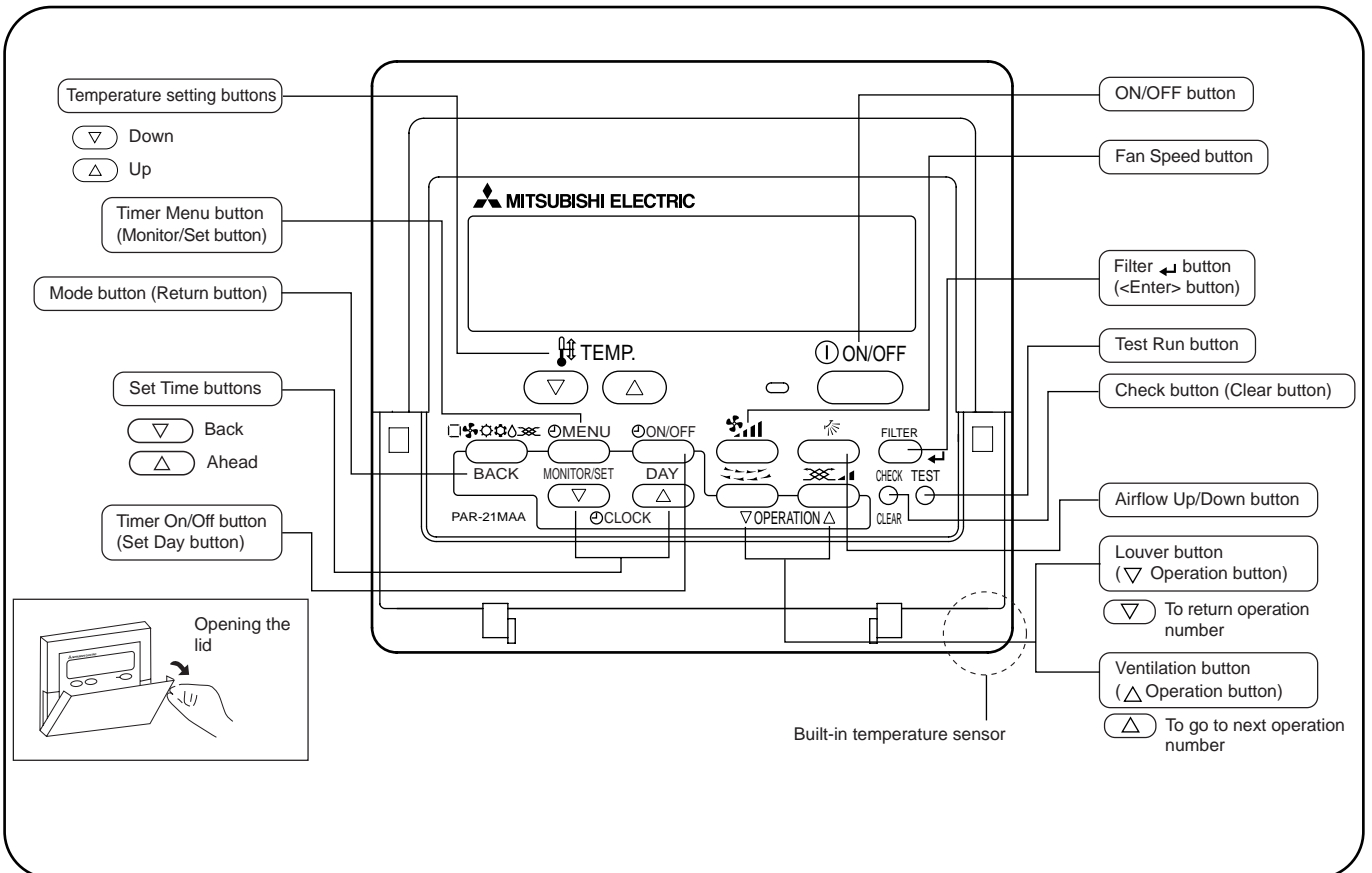

● Wired remote controller

Display Section

For purposes of this explanation, all parts of the display are shown as lit. During actual operation, only the relevant items will be lit.

Identifies the current operation

Shows the operating mode, etc.
*Multilanguage display is available.

“Centrally Controlled” indicator

Indicates that operation from the remote controller has been prohibited by a master controller.

“Timer is Off” indicator

Indicates that the timer is off.

Temperature Setting

Shows the target temperature.

Day-of-Week

Shows the current day of the week.

Time/Timer Display

Shows the current time, unless the simple or Auto Off timer is set.
If the simple or Auto Off timer is set, the time to be switched off is shown.

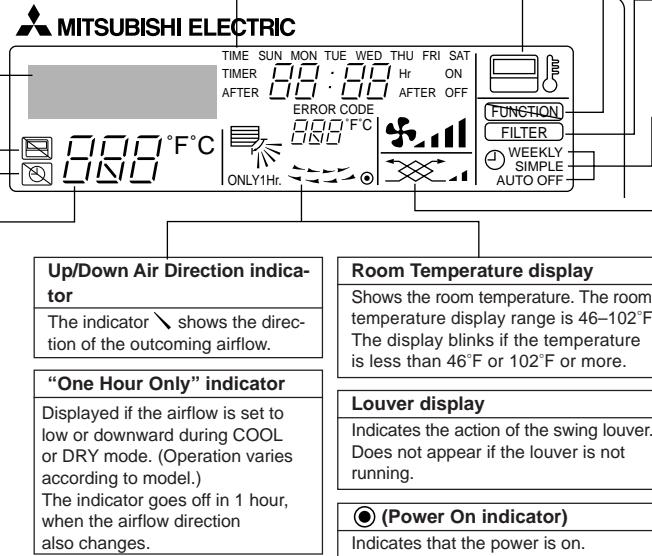

Note:

- “PLEASE WAIT” message
This message is displayed for approximately 3 minutes when power is supplied to the indoor unit or when the unit is recovering from a power failure.
- “NOT AVAILABLE” message
This message is displayed if an invalid button is pressed (to operate a function that the indoor unit does not have).
If a single remote controller is used to operate multiple indoor units simultaneously that are different types, this message will not be displayed as far as any of the indoor units is equipped with the function.

● Wireless remote controller

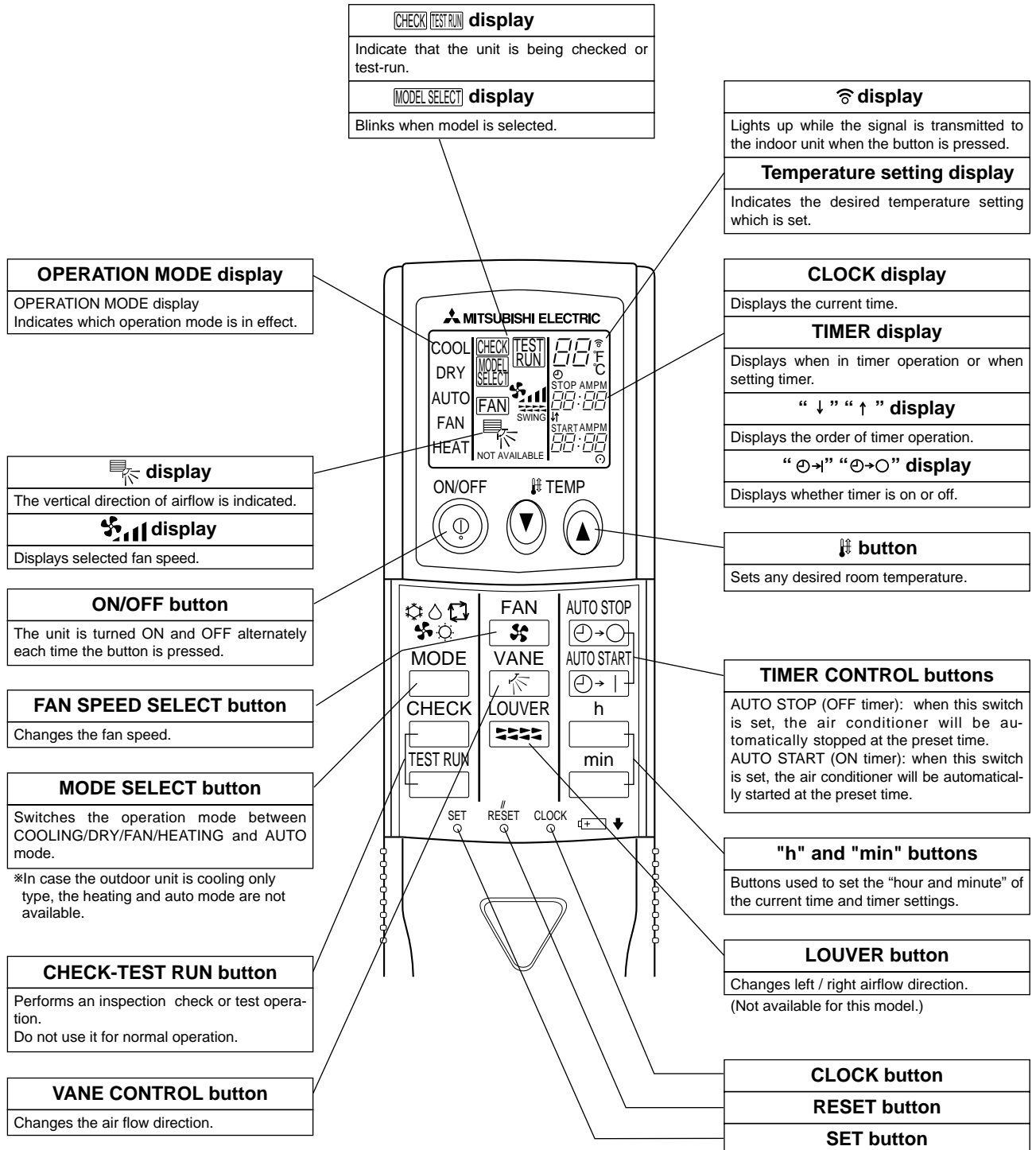

5

SPECIFICATIONS

Service Ref.			PCA-A24GA, PCA-A24GA ₁ , PCA-A24GA ₂
Power supply(phase, cycle, voltage)			Single phase, 60Hz, 208/230V
Max. Fuse Size		A	15
Min.Circuit Ampacity		A	1
External finish			Munsell 0.70Y 8.59/0.97
Heat exchanger			Plate fin coil
INDOOR UNIT	Fan	Fan(drive) × No.	Sirocco fan (direct) × 3
	Fan motor output		kW
	Fan motor		F.L.A
	Airflow(Low-Medium2-Medium1-High)		m ³ /min(CFM)
	External static pressure		Pa(mmAq)
Operation control & Thermostat			Remote controller & built-in
Noise level(Low-Medium2-Medium1-High)		dB	37-39-41-43
Field drain pipe O.D.		mm(in.)	26(1-1/32)
Dimensions	W	mm(in.)	1,310(51-9/16)
	D	mm(in.)	680(26-25/32)
	H	mm(in.)	210(8-9/32)
Weight		kg(lbs)	34(75)

Service Ref.			PCA-A30GA, PCA-A30GA ₁ , PCA-A30GA ₂
Power supply(phase, cycle, voltage)			Single phase, 60Hz, 208/230V
Max. Fuse Size		A	15
Min.Circuit Ampacity		A	1
External finish			Munsell 0.70Y 8.59/0.97
Heat exchanger			Plate fin coil
INDOOR UNIT	Fan	Fan(drive) × No.	Sirocco fan (direct) × 3
	Fan motor output		kW
	Fan motor		F.L.A
	Airflow(Low-Medium2-Medium1-High)		m ³ /min(CFM)
	External static pressure		Pa(mmAq)
Operation control & Thermostat			Remote controller & built-in
Noise level(Low-Medium2-Medium1-High)		dB	37-39-41-43
Field drain pipe O.D.		mm(in.)	26(1-1/32)
Dimensions	W	mm(in.)	1,310(51-9/16)
	D	mm(in.)	680(26-25/32)
	H	mm(in.)	210(8-9/32)
Weight		kg(lbs)	34(75)

Service Ref.			PCA-A36GA, PCA-A36GA ₁ , PCA-A36GA ₂
Power supply(phase, cycle, voltage)			Single phase, 60Hz, 208/230V
Max. Fuse Size		A	15
Min.Circuit Ampacity		A	1
External finish			Munsell 0.70Y 8.59/0.97
Heat exchanger			Plate fin coil
INDOOR UNIT	Fan	Fan(drive) × No.	Sirocco fan (direct) × 3
	Fan motor output		kW
	Fan motor		F.L.A
	Airflow(Low-Medium2-Medium1-High)		m ³ /min(CFM)
	External static pressure		Pa(mmAq)
Operation control & Thermostat			Remote controller & built-in
Noise level(Low-Medium2-Medium1-High)		dB	40-41-43-45
Field drain pipe O.D.		mm(in.)	26(1-1/32)
Dimensions	W	mm(in.)	1,310(51-9/16)
	D	mm(in.)	680(26-25/32)
	H	mm(in.)	270(10-5/8)
Weight		kg(lbs)	37(82)

INDOOR UNIT	Service Ref.		PCA-A42GA, PCA-A42GA₁, PCA-A42GA₂		
	Power supply(phase, cycle, voltage)		Single phase, 60Hz, 208/230V		
	Max. Fuse Size	A	15		
	Min.Circuit Ampacity	A	1		
	External finish		Munsell 0.70Y 8.59/0.97		
	Heat exchanger		Plate fin coil		
	Fan	Fan(drive) × No.		Sirocco fan (direct) × 3	
		Fan motor output	kW	0.090	
		Fan motor	F.L.A	0.69	
		Airflow(Low-Medium2-Medium1-High)	m ³ /min(CFM)	Dry: 20-21-23-25(705-740-810-885) Wet:18-19-21-22(635-670-730-790)	
		External static pressure	Pa(mmAq)	0(direct blow)	
	Operation control & Thermostat		Remote controller & built-in		
	Noise level(Low-Medium2-Medium1-High)		dB		
Field drain pipe O.D.		mm(in.)			
Dimensions	W	mm(in.)	1,310(51-9/16)		
	D	mm(in.)	680(26-25/32)		
	H	mm(in.)	270(10-5/8)		
Weight		kg(lbs)			
		37(82)			

6

NOISE CRITERION CURVES

PCA-A24GA PCA-A24GA₂
 PCA-A30GA PCA-A30GA₂
 PCA-A24GA₁
 PCA-A30GA₁

NOTCH	SPL(dB)	LINE
High	43	○—○
Medium1	41	△—△
Medium2	39	●—●
Low	37	▲—▲

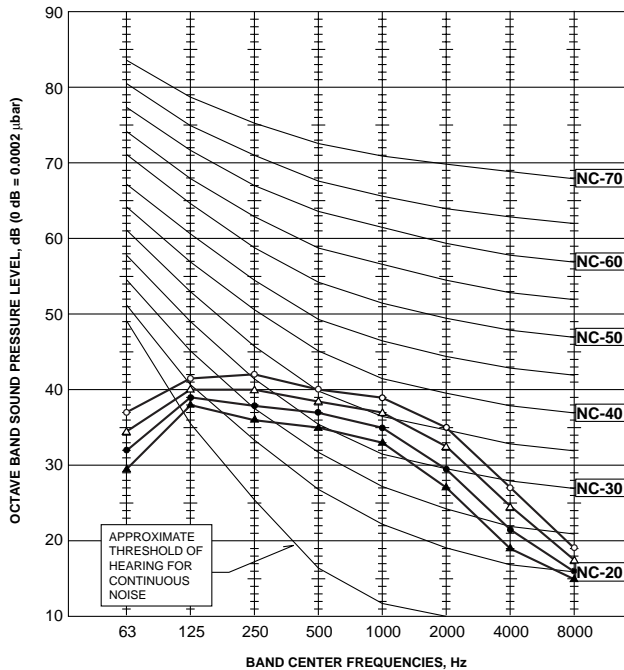

PCA-A36GA PCA-A36GA₂
 PCA-A42GA PCA-A42GA₂
 PCA-A36GA₁
 PCA-A42GA₁

NOTCH	SPL(dB)	LINE
High	45	○—○
Medium1	43	△—△
Medium2	41	●—●
Low	40	▲—▲

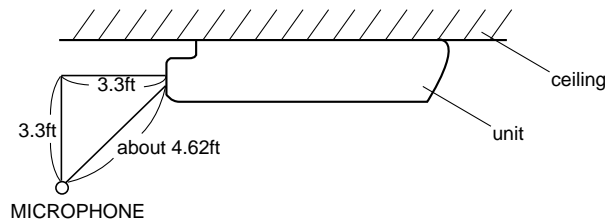
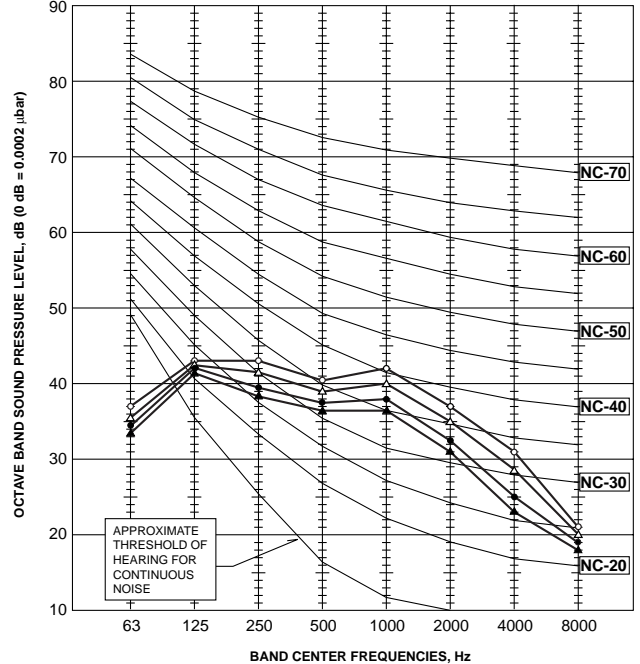

7

OUTLINES AND DIMENSIONS

PCA-A24GA PCA-A24GA₁ PCA-A24GA₂
 PCA-A30GA PCA-A30GA₁ PCA-A30GA₂

Unit : inch(mm)

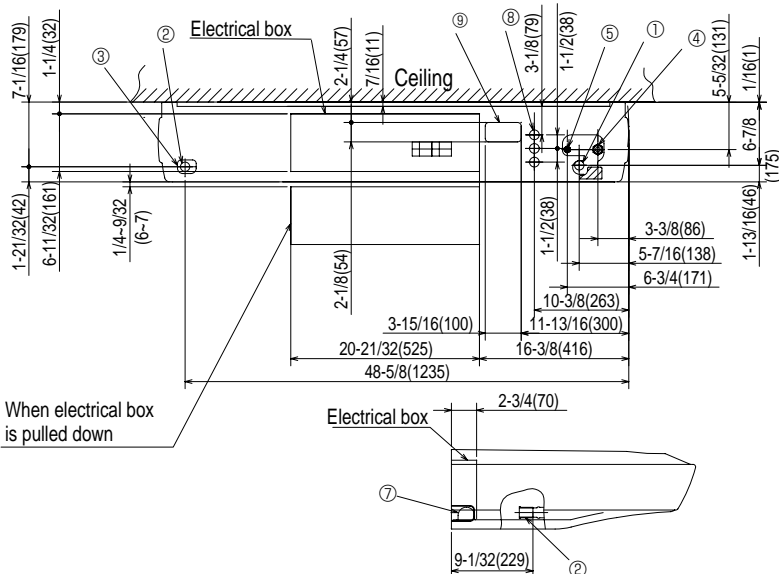
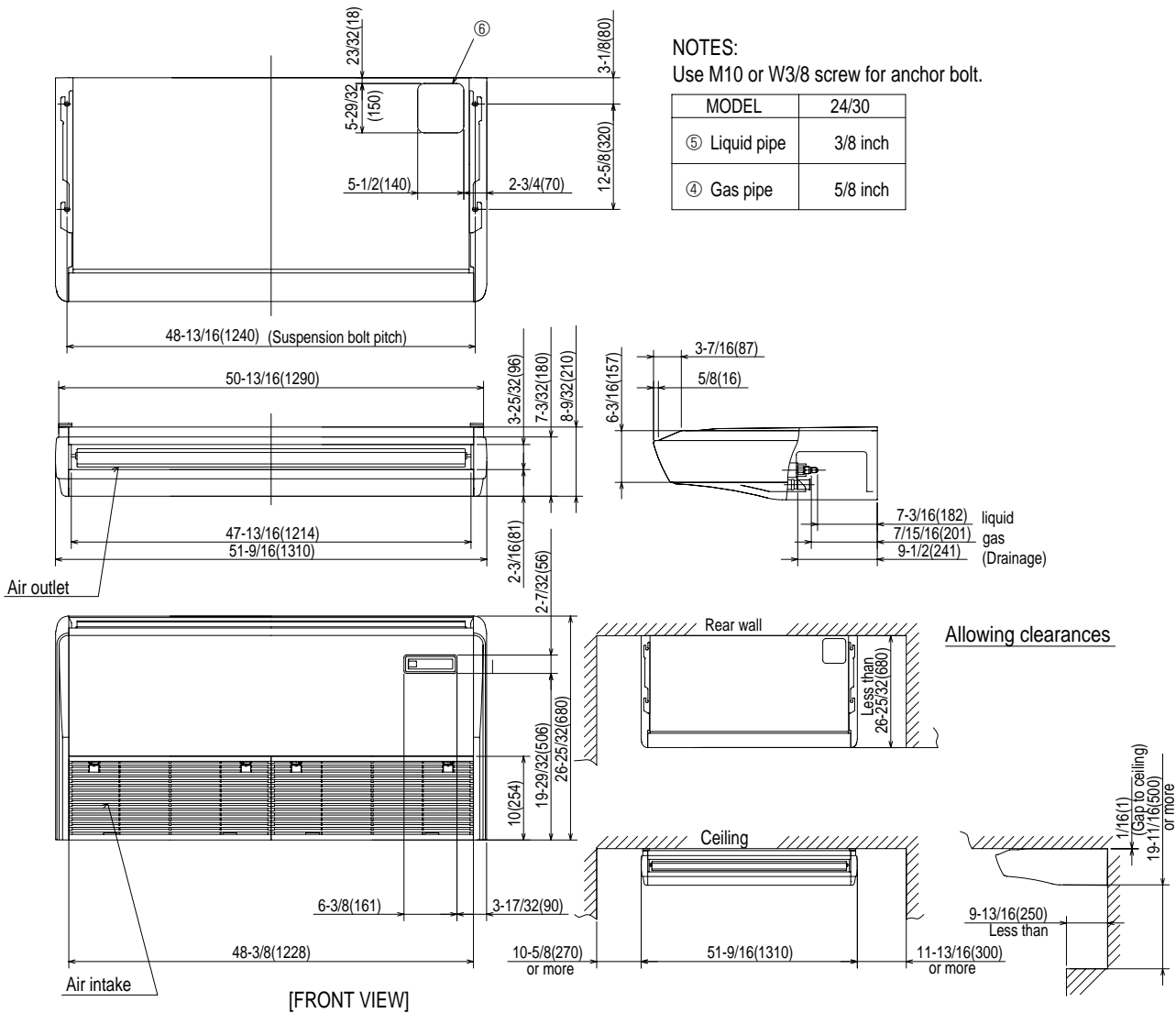

- ① Drainage pipe connection(1-1/32(26mm)I.D.)
- ② Drainage pipe connection(for the left arrangement)
- ③ Knockout hole for left drain-piping arrangement
- ④ Refrigerant-pipe connection(gas pipe side/flared connection)
- ⑤ Refrigerant-pipe connection(liquid pipe side/flared connection)
- ⑥ Knockout hole for upper pipe arrangement
- ⑦ Knockout hole for left drain pipe arrangement
- ⑧ Knockout hole for wiring arrangement
- ⑨ Knockout hole for fresh air intake

PCA-A36GA PCA-A36GA₁ PCA-A36GA₂
 PCA-A42GA PCA-A42GA₁ PCA-A42GA₂

Unit : inch(mm)

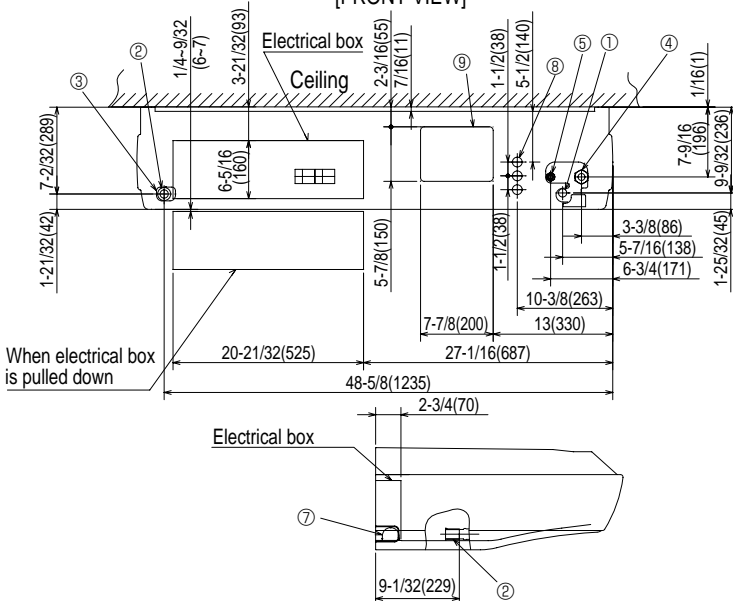
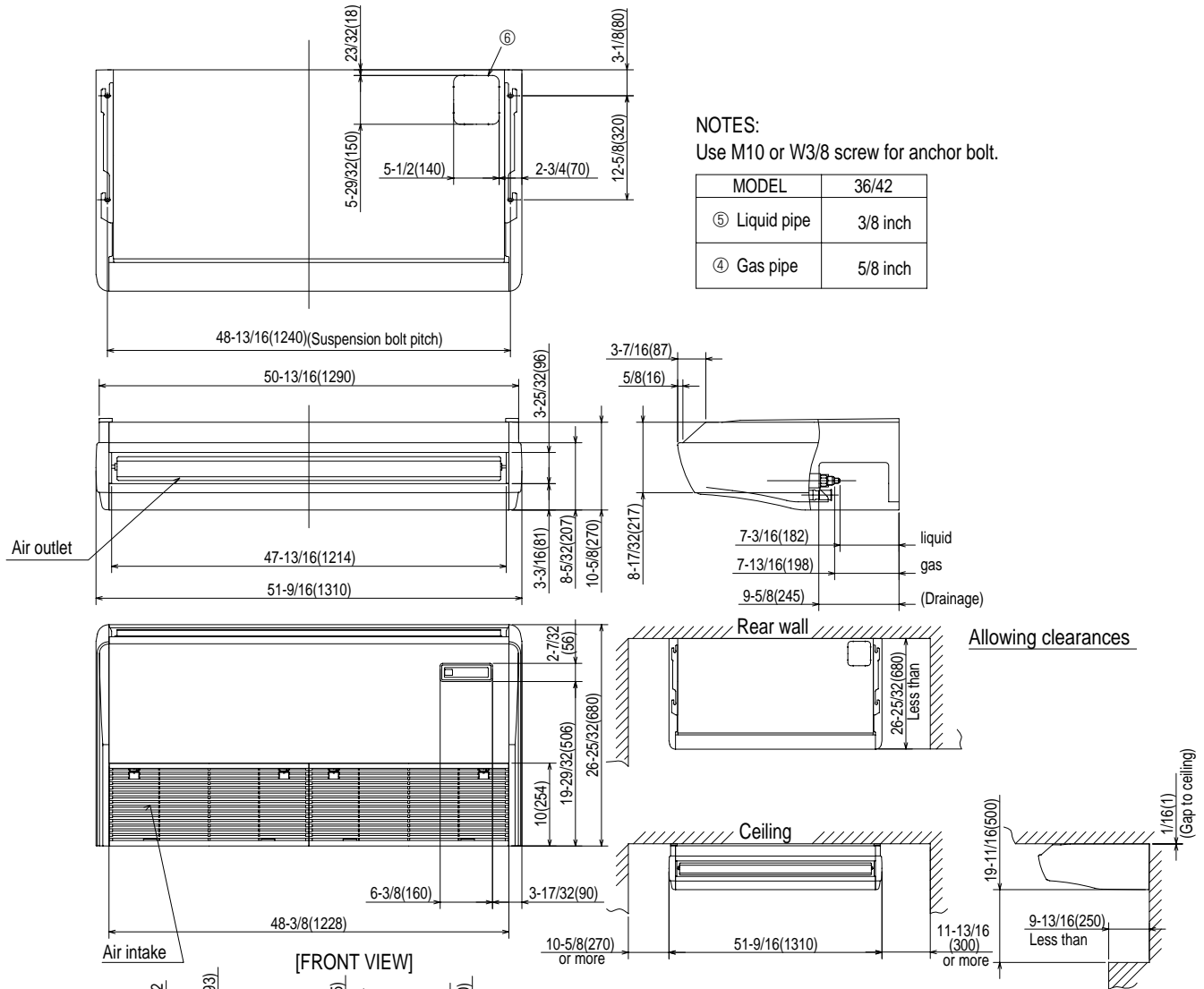

- ① Drainage pipe connection(1-1/32(26mm)I.D.)
- ② Drainage pipe connection(for the left arrangement)
- ③ Knockout hole for left drain-piping arrangement
- ④ Refrigerant-pipe connection(gas pipe side/flared connection)
- ⑤ Refrigerant-pipe connection(liquid pipe side/flared connection)
- ⑥ Knockout hole for upper pipe arrangement
- ⑦ Knockout hole for left drain pipe arrangement
- ⑧ Knockout hole for wiring arrangement
- ⑨ Knockout hole for fresh air intake

WIRING DIAGRAM

PCA-A24GA PCA-A30GA PCA-A36GA PCA-A42GA
 PCA-A24GA₁ PCA-A30GA₁ PCA-A36GA₁ PCA-A42GA₁

[LEGEND]

SYMBOL	NAME	SYMBOL	NAME	SYMBOL	NAME
P.B	INDOOR POWER BOARD	C	CAPACITOR<-FAN MOTOR>	W.B	WIRELESS REMOTE CONTROLLER BOARD(OPTION)
I.B	INDOOR CONTROLLER BOARD	MF	FAN MOTOR	RU	RECEIVING UNIT
FUSE	FUSE (6.3A/250V)	MV	VANE MOTOR	BZ	BUZZER
ZNR	VARISTOR	TB4	TERMINAL BLOCK<-INDOOR/OUTDOOR CONNECTING LINE>	LED1	LED<-RUN INDICATOR >
CN2L	CONNECTOR<-LOSSNAY>	TB5,TB6	TERMINAL BLOCK<-REMOTE CONTROLLER TRANSMISSION LINE >	LED2	LED<-HOT ADJUST>
CN32	CONNECTOR<-REMOTE SWITCH>	TH1	ROOM TEMP.THERMISTOR <32°F/15kΩ, 77°F/5.2kΩ DETECT>	SW1	SWITCH<-HEATING ON/OFF>
CN41	CONNECTOR<-HA TERMINAL-A>	TH2	PIPE TEMP.THERMISTOR/LIQUID <32°F/15kΩ, 77°F/5.2kΩ DETECT>	SW2	SWITCH<-COOLING ON/OFF>
CN51	CONNECTOR<-CENTRALLY CONTROL>	TH5	COND./EVA.TEMP.THERMISTOR <32°F/15kΩ, 77°F/5.2kΩ DETECT>		
SW1	SWITCH <-MODEL SELECTION>*See Table 1.	R.B	WIRED REMOTE CONTROLLER BOARD		
SW2	SWITCH <-CAPACITY CODE>*See Table 2.				
SWE	SWITCH<-EMERGENCY OPERATION>				
X1	RELAY<-DRAIN PUMP>				
X4	RELAY<-FAN MOTOR>				
BCR	FAN CONTROL ELEMENT				
LED1	POWER SUPPLY<-I.B>				
LED2	POWER SUPPLY<-R.B>				
LED3	TRANSMISSION<-INDOOR-OUTDOOR>				

Please set the voltage using the remote controller.
 For the setting method, please refer to the indoor unit Installation Manual.

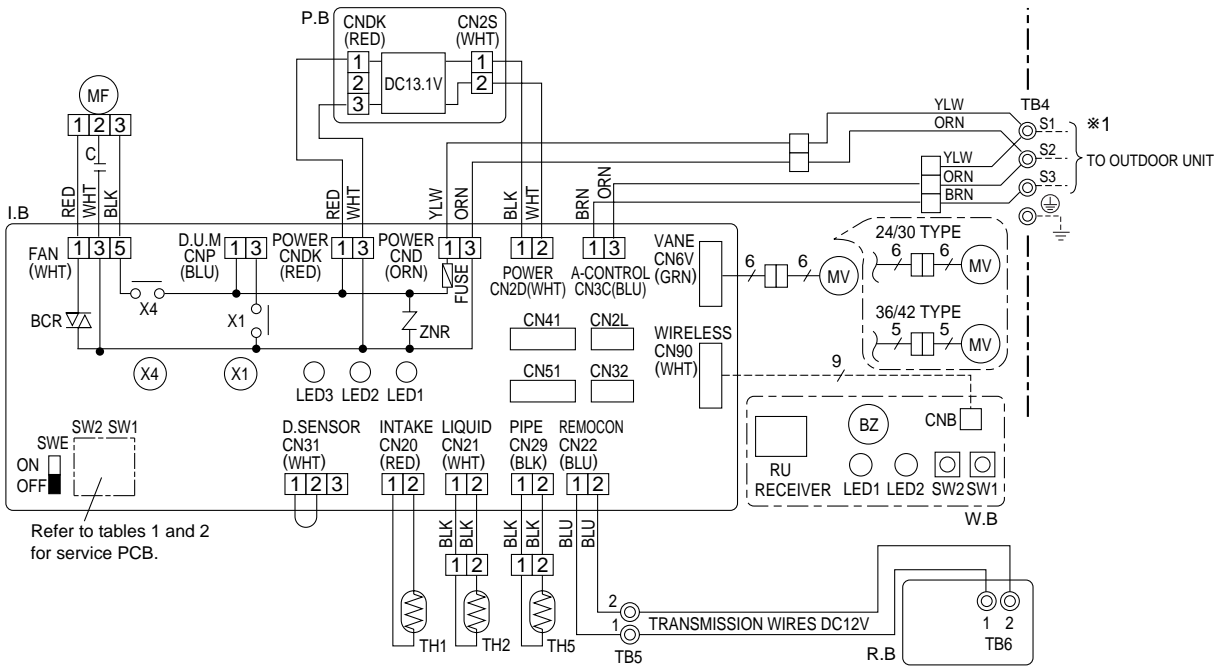

Table 1

MODELS	Service board															
PCA-A,GGA	<table border="1"> <tr> <td>1</td><td>2</td><td>3</td><td>4</td><td>5</td> </tr> <tr> <td>ON</td><td>ON</td><td>ON</td><td>ON</td><td>ON</td> </tr> <tr> <td>OFF</td><td>OFF</td><td>OFF</td><td>OFF</td><td>OFF</td> </tr> </table>	1	2	3	4	5	ON	ON	ON	ON	ON	OFF	OFF	OFF	OFF	OFF
1	2	3	4	5												
ON	ON	ON	ON	ON												
OFF	OFF	OFF	OFF	OFF												

Table 2

MODELS	Service board	MODELS	Service board																														
PCA-A24GA	<table border="1"> <tr> <td>1</td><td>2</td><td>3</td><td>4</td><td>5</td> </tr> <tr> <td>ON</td><td>ON</td><td>ON</td><td>ON</td><td>ON</td> </tr> <tr> <td>OFF</td><td>OFF</td><td>OFF</td><td>OFF</td><td>OFF</td> </tr> </table>	1	2	3	4	5	ON	ON	ON	ON	ON	OFF	OFF	OFF	OFF	OFF	PCA-A36GA	<table border="1"> <tr> <td>1</td><td>2</td><td>3</td><td>4</td><td>5</td> </tr> <tr> <td>ON</td><td>ON</td><td>ON</td><td>ON</td><td>ON</td> </tr> <tr> <td>OFF</td><td>OFF</td><td>OFF</td><td>OFF</td><td>OFF</td> </tr> </table>	1	2	3	4	5	ON	ON	ON	ON	ON	OFF	OFF	OFF	OFF	OFF
1	2	3	4	5																													
ON	ON	ON	ON	ON																													
OFF	OFF	OFF	OFF	OFF																													
1	2	3	4	5																													
ON	ON	ON	ON	ON																													
OFF	OFF	OFF	OFF	OFF																													
PCA-A30GA	<table border="1"> <tr> <td>1</td><td>2</td><td>3</td><td>4</td><td>5</td> </tr> <tr> <td>ON</td><td>ON</td><td>ON</td><td>ON</td><td>ON</td> </tr> <tr> <td>OFF</td><td>OFF</td><td>OFF</td><td>OFF</td><td>OFF</td> </tr> </table>	1	2	3	4	5	ON	ON	ON	ON	ON	OFF	OFF	OFF	OFF	OFF	PCA-A42GA	<table border="1"> <tr> <td>1</td><td>2</td><td>3</td><td>4</td><td>5</td> </tr> <tr> <td>ON</td><td>ON</td><td>ON</td><td>ON</td><td>ON</td> </tr> <tr> <td>OFF</td><td>OFF</td><td>OFF</td><td>OFF</td><td>OFF</td> </tr> </table>	1	2	3	4	5	ON	ON	ON	ON	ON	OFF	OFF	OFF	OFF	OFF
1	2	3	4	5																													
ON	ON	ON	ON	ON																													
OFF	OFF	OFF	OFF	OFF																													
1	2	3	4	5																													
ON	ON	ON	ON	ON																													
OFF	OFF	OFF	OFF	OFF																													

- NOTES:
- Since the outdoor side electric wiring may change, be sure to check the outdoor unit electric wiring for servicing.
 - Indoor and outdoor connecting wires have polarities, make sure to match terminal numbers (S1, S2, S3) for correct wirings.
 - Symbols used in wiring diagram above are, □ : Connector, ⊙ : Terminal (block).
 - This diagram shows the wiring of Indoor and Outdoor connecting wires (specification of 230V), adopting superimposed system of power and signal.
- ※1. Use copper supply wires.

[Emergency operation procedure]
 When the wired remote control or the indoor unit microcomputer has failed, but all other components work properly, if you set the switch (SWE) on the indoor control board ON, the indoor unit will begin Emergency Operation.
 When Emergency Operation is activated, indoor fan runs at high speed.

PCA-A24GA₂ PCA-A30GA₂ PCA-A36GA₂ PCA-A42GA₂

LEGEND

SYMBOL	NAME	SYMBOL	NAME	SYMBOL	NAME
P.B	INDOOR POWER BOARD	LED2	POWER SUPPLY<R.B>	W.B	WIRELESS REMOTE CONTROLLER BOARD(OPTION)
I.B	INDOOR CONTROLLER BOARD	LED3	TRANSMISSION<INDOOR-OUTDOOR>	RU	RECEIVING UNIT
FUSE	FUSE (6.3A/250V)	C	CAPACITOR<FAN MOTOR>	BZ	BUZZER
ZNR	VARIATOR	MF	FAN MOTOR	LED1	LED-RUN INDICATOR >
CN2L	CONNECTOR<LOSSNAY>	MV	VANE MOTOR	LED2	LED-HOT ADJUST>
CN24	CONNECTOR<BACK-UP HEATING>	TB4	TERMINAL BLOCK<INDOOR/OUTDOOR CONNECTING LINE>	SW1	SWITCH<HEATING ON/OFF>
CN30	CONNECTOR<LLC>	TB5, TB6	TERMINAL BLOCK<REMOTE CONTROLLER TRANSMISSION LINE >	SW2	SWITCH<COOLING ON/OFF>
CN32	CONNECTOR<REMOTE SWITCH>				
CN41	CONNECTOR<HA TERMINAL-A>				
CN51	CONNECTOR<CENTRALLY CONTROL>	TH1	ROOM TEMP.THERMISTOR <32°F/15kΩ, 77°F/5.2kΩ DETECT>		
SW1	SWITCH <MODEL SELECTION>*See Table 1.	TH2	PIPE TEMP.THERMISTOR/LIQUID <32°F/15kΩ, 77°F/5.2kΩ DETECT>		
SW2	SWITCH <CAPACITY CODE>*See Table 2.	TH5	COND./EVA.TEMP.THERMISTOR <32°F/15kΩ, 77°F/5.2kΩ DETECT>		
SWE	SWITCH<EMERGENCY OPERATION>	R.B	WIRED REMOTE CONTROLLER BOARD		
X1	RELAY<DRAIN PUMP>				
X4	RELAY<FAN MOTOR>				
BCR	FAN CONTROL ELEMENT				
LED1	POWER SUPPLY<I.B>				

Please set the voltage using the remote controller.
For the setting method, please refer to the indoor unit Installation Manual

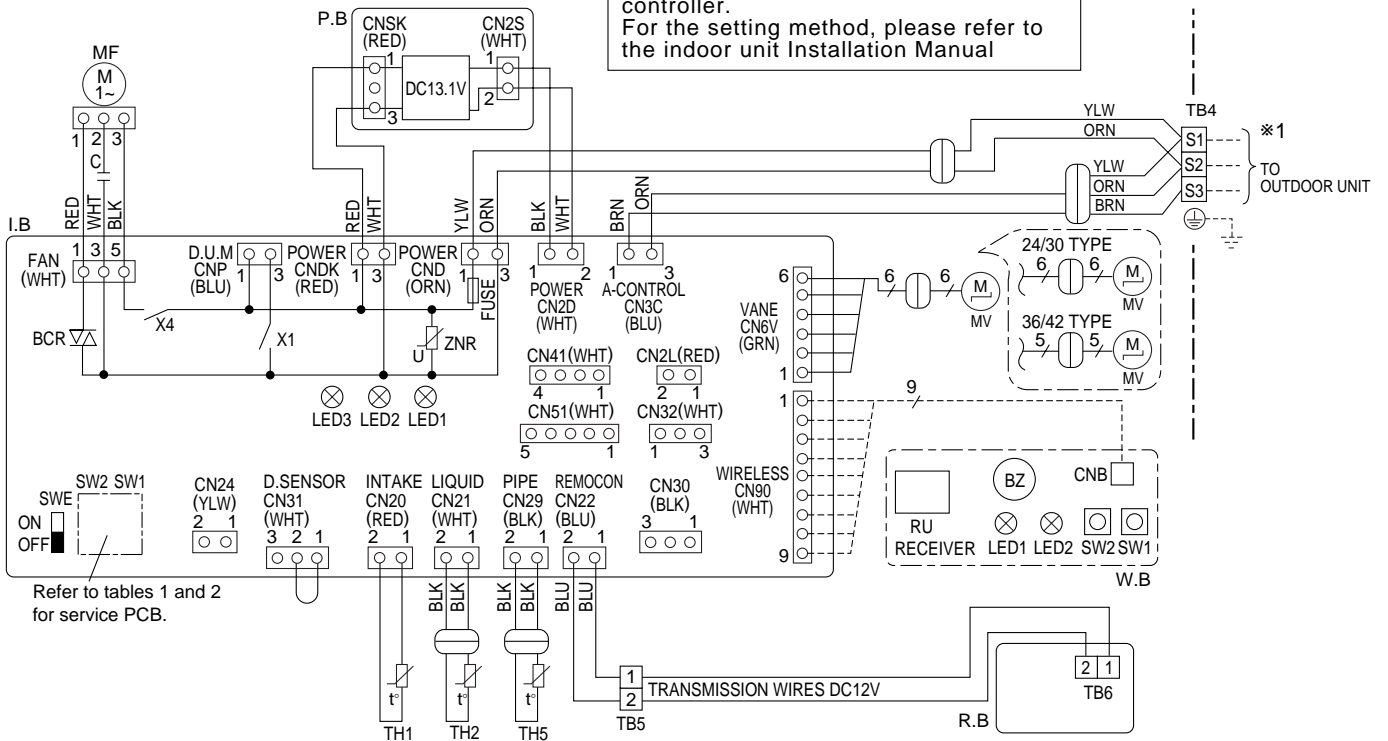

Table 1

SW1	
MODELS	Service board
PCA-A,GA	

Table 2

SW2			
MODELS	Service board	MODELS	Service board
PCA-A24GA		PCA-A36GA	
PCA-A30GA		PCA-A42GA	

NOTES:

- Since the outdoor side electric wiring may change, be sure to check the outdoor unit electric wiring for servicing.
 - Indoor and outdoor connecting wires have polarities, make sure to match terminal numbers (S1, S2, S3) for correct wirings.
 - Symbols used in wiring diagram above are, : Connector, : Terminal (block).
 - This diagram shows the wiring of Indoor and Outdoor connecting wires (specification of 230V), adopting superimposed system of power and signal.
- *1.Use copper supply wires.

[Emergency operation procedure]

When the wired remote control or the indoor unit microcomputer has failed, but all other components work properly, if you set the switch (SWE) on the indoor control board ON, the indoor unit will begin Emergency Operation.
When Emergency Operation is activated, indoor fan runs at high speed.

9

REFRIGERANT SYSTEM DIAGRAM

PCA-A24GA	PCA-A30GA	PCA-A36GA	PCA-A42GA
PCA-A24GA ₁	PCA-A30GA ₁	PCA-A36GA ₁	PCA-A42GA ₁
PCA-A24GA ₂	PCA-A30GA ₂	PCA-A36GA ₂	PCA-A42GA ₂

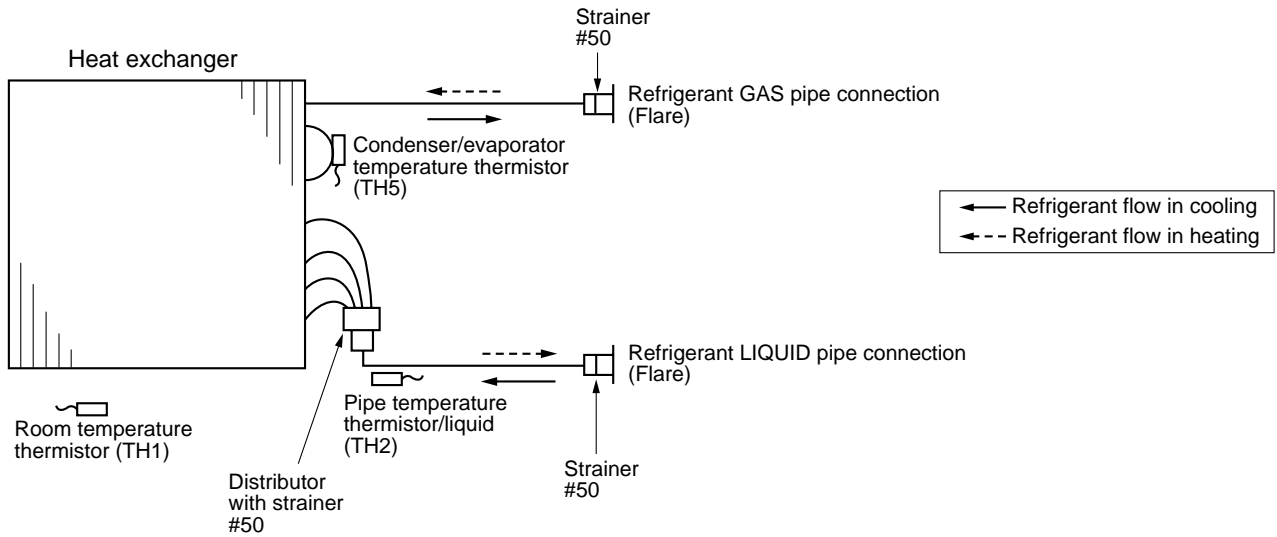

10-1. TROUBLESHOOTING

<Error code display by self-diagnosis and actions to be taken for service (summary)>

Present and past error codes are logged and displayed on the wired remote controller or controller board of outdoor unit. Actions to be taken for service and the trouble recurrence at field are summarized in the table below. Check the contents below before investigating details.

Unit conditions at service	Error code	Actions to be taken for service (summary)
The trouble is reoccurring.	Displayed	Judge what is wrong and take a corrective action according to "SELF-DIAGNOSIS ACTION TABLE" (10-2).
	Not displayed	Identify the cause of the trouble and take a corrective action according to "TROUBLESHOOTING BY INFERIOR PHENOMENA" (10-3).
The trouble is not reoccurring.	Logged	<ul style="list-style-type: none"> ①Consider the temporary defects such as the work of protection devices in the refrigerant circuit including compressor, poor connection of wiring, noise and etc. Re-check the symptom, and check the installation environment, refrigerant amount, weather when the trouble occurred, and wiring related. ②Reset error code logs and restart the unit after finishing service. ③There is no abnormality in electrical components, controller boards, and remote controller.
	Not logged	<ul style="list-style-type: none"> ①Recheck the abnormal symptom. ②Identify the cause of the trouble and take a corrective action according to "TROUBLESHOOTING BY INFERIOR PHENOMENA" (10-3). ③Continue to operate unit for the time being if the cause is not ascertained. ④There is no abnormality in electrical components, controller boards, remote controller etc.

Note: Refer to the manual of outdoor unit for the details of display such as F, U, and other E.

10-2. SELF-DIAGNOSIS ACTION TABLE

Error Code	Abnormal point and detection method	Cause	Countermeasure
P1	<p>Room temperature thermistor (TH1)</p> <p>① The unit is in 3-minute resume prevention mode if short/open of thermistor is detected. Abnormal if the unit does not reset normally after 3 minutes. (The unit returns to normal operation, if it has been reset normally.)</p> <p>② Constantly detected during cooling, drying, and heating operation. Short: 90°C (194°F) or more Open: -40°C (-40°F) or less</p>	<p>① Defective thermistor characteristics</p> <p>② Contact failure of connector (CN20) on the indoor controller board (Insert failure)</p> <p>③ Breaking of wire or contact failure of thermistor wiring</p> <p>④ Defective indoor controller board</p>	<p>①-③ Check resistance value of thermistor. 0°C (32°F).....15.0kΩ 10°C (50°F).....9.6kΩ 20°C (68°F).....6.3kΩ 30°C (86°F).....4.3kΩ 40°C (104°F).....3.0kΩ</p> <p>If you put force on (draw or bend) the lead wire with measuring resistance value of thermistor breaking of wire or contact failure can be detected.</p> <p>② Check contact failure of connector (CN20) on the indoor controller board. Refer to 10-6. Turn the power on again and check restart after inserting connector again.</p> <p>④ Check room temperature display on remote controller. Replace indoor controller board if there is abnormal difference with actual room temperature.</p> <p>Turn the power off, and on again to operate after check.</p>
P2	<p>Pipe temperature thermistor/Liquid (TH2)</p> <p>① The unit is in 3-minute resume prevention mode if short/open of thermistor is detected. Abnormal if the unit does not reset normally after 3 minutes. (The unit returns to normal operation, if it has been reset normally.)</p> <p>② Constantly detected during cooling, drying, and heating (except defrosting) operation. Short: 90°C (194°F) or more Open: -40°C (-40°F) or less</p>	<p>① Defective thermistor characteristics</p> <p>② Contact failure of connector (CN21) on the indoor controller board (Insert failure)</p> <p>③ Breaking of wire or contact failure of thermistor wiring</p> <p>④ Defective refrigerant circuit is causing thermistor temperature of 90°C (194°F) or more or -40°C (-40°F) or less.</p> <p>⑤ Defective indoor controller board</p>	<p>①-③ Check resistance value of thermistor. For characteristics, refer to (P1) above.</p> <p>② Check contact failure of connector (CN21) on the indoor controller board. Refer to 10-6. Turn the power on and check restart after inserting connector again.</p> <p>④ Check pipe <liquid> temperature with remote controller in test run mode. If pipe <liquid> temperature is extremely low (in cooling mode) or high (in heating mode), refrigerant circuit may have defect.</p> <p>⑤ Check pipe <liquid> temperature with remote controller in test run mode. If there is extreme difference with actual pipe <liquid> temperature, replace indoor controller board.</p> <p>Turn the power off, and on again to operate after check.</p>
P4	<p>Drain sensor (DS)</p> <p>① Suspensive abnormality, if short/open of thermistor is detected for 30 seconds continuously. Turn off compressor and indoor fan.</p> <p>② Short/open is detected for 30 seconds continuously during suspensive abnormality. (The unit returns to normal operation, if it has been reset normally.)</p> <p>③ Detect the following condition.</p> <ul style="list-style-type: none"> • During cooling and drying operation • In case that pipe <liquid> temperature - room temperature <-10deg (Except defrosting) • When pipe <liquid> temperature or room temperature is short/open temperature. • During drain pump operation 	<p>① Defective thermistor characteristics</p> <p>② Contact failure of connector (CN31) on the indoor controller board (Insert failure)</p> <p>③ Breaking of wire or contact failure of drain sensor wiring</p> <p>④ Defective indoor controller board</p>	<p>①-③ Check resistance value of thermistor. 0°C (32°F).....6.0kΩ 10°C (50°F).....3.9kΩ 20°C (68°F).....2.6kΩ 30°C (86°F).....1.8kΩ 40°C (104°F).....1.3kΩ</p> <p>② Check contact failure of connector (CN31) on the indoor controller board. Refer to 10-6. Turn the power on again and check restart after inserting connector again.</p> <p>④ Replace indoor controller board if drain pump operates with the line of drain sensor connector CN31-① and ② is short-circuited, and abnormality reappears.</p> <p>Turn the power off, and on again to operate after check.</p>
P5	<p>Malfunction of drain pump (DP)</p> <p>① Suspensive abnormality, if thermistor of drain sensor heats itself and temperature rises slightly. Turn off compressor and indoor fan.</p> <p>② Drain pump is abnormal if the condition above is detected during suspensive abnormality.</p> <p>③ Constantly detected during drain pump operation.</p>	<p>① Malfunction of drain pump</p> <p>② Defective drain Clogged drain pump Clogged drain pipe</p> <p>③ Attached drop of water at the drain sensor</p> <ul style="list-style-type: none"> • Drops of drain trickles from lead wire. • Clogged filter is causing wave of drain. <p>④ Defective indoor controller board</p>	<p>① Check if drain pump works.</p> <p>② Check drain function.</p> <p>③ Check the setting of lead wire of drain sensor and check clogs of the filter.</p> <p>④ Replace indoor controller board if drain pump operates with the line of drain sensor connector CN31-① and ② is short-circuited and abnormality reappears. Refer to 10-6.</p> <p>Turn the power off, and on again to operate after check.</p>

Error Code	Abnormal point and detection method	Cause	Countermeasure
P6	<p>Freezing/overheating protection is working</p> <p>① Freezing protection (Cooling mode) The unit is in 6-minute resume prevention mode if pipe <liquid or condenser/evaporator> temperature stays under -15°C (5°F) for 3 minutes, 3 minutes after the compressor started. Abnormal if it stays under -15°C (5°F) for 3 minutes again within 16 minutes after 6-minute resume prevention mode.</p> <p>② Overheating protection (Heating mode) The units is in 6-minute resume prevention mode if pipe <condenser / evaporator> temperature is detected as over 70°C (158°F) after the compressor started. Abnormal if the temperature of over 70°C (158°F) is detected again within 10 minutes after 6-minute resume prevention mode.</p>	<p>(Cooling or drying mode)</p> <p>① Clogged filter (reduced airflow) ② Short cycle of air path ③ Low-load (low temperature) operation out of the tolerance range ④ Defective indoor fan motor • Fan motor is defective. • Indoor controller board is defective.</p> <p>⑤ Defective outdoor fan control ⑥ Overcharge of refrigerant ⑦ Defective refrigerant circuit (clogs)</p> <p>(Heating mode)</p> <p>① Clogged filter (reduced airflow) ② Short cycle of air path ③ Overload (high temperature) operation out of the tolerance range ④ Defective indoor fan motor • Fan motor is defective. • Indoor controller board is defective.</p> <p>⑤ Defective outdoor fan control ⑥ Overcharge of refrigerant ⑦ Defective refrigerant circuit (clogs) ⑧ Bypass circuit of outdoor unit is defective.</p>	<p>(Cooling or drying mode)</p> <p>① Check clogs of the filter. ② Remove shields.</p> <p>④ Measure the resistance of fan motor's winding. Measure the output voltage of fan's connector (FAN) on the indoor controller board. *The indoor controller board should be normal when voltage of AC 208/230V is detected while fan motor is connected. Refer to 10-6. ⑤ Check outdoor fan motor. ⑥⑦ Check operating condition of refrigerant circuit.</p> <p>(Heating mode)</p> <p>① Check clogs of the filter. ② Remove shields.</p> <p>④ Measure the resistance of fan motor's winding. Measure the output voltage of fan's connector (FAN) on the indoor controller board. *The indoor controller board should be normal when voltage of AC 208/230V is detected while fan motor is connected. Refer to 10-6. ⑤ Check outdoor fan motor. ⑥-⑧ Check operating condition of refrigerant circuit.</p>
P8	<p>Pipe temperature <Cooling mode> Detected as abnormal when the pipe temperature is not in the cooling range 3 minutes after the liquid or condenser/evaporator pipe is out of cooling range. Note 1) It takes at least 9 minutes to detect. Note 2) Abnormality P8 is not detected in drying mode. Cooling range:-3 deg C[-5.4deg F]≥(TH-TH1) TH: Lower temperature between liquid pipe temperature (TH2) and condenser/evaporator temperature (TH5) TH1: Intake temperature</p> <p><Heating mode> When 10 seconds have passed after the compressor starts operation and the hot adjustment mode has finished, the unit is detected as abnormal when condenser/evaporator pipe temperature is not in heating range within 20 minutes. Note 3) It takes at least 27 minutes to detect abnormality. Note 4) It excludes the period of defrosting (Detection restarts when defrosting mode is over) Heating range:3 deg C[5.4deg F]≤(TH5-TH1)</p>	<p>① Slight temperature difference between indoor room temperature and pipe <liquid or condenser / evaporator> temperature thermistor • Shortage of refrigerant • Disconnected holder of pipe <liquid or condenser / evaporator> thermistor • Defective refrigerant circuit</p> <p>② Converse connection of extension pipe (on plural units connection) ③ Converse wiring of indoor/outdoor unit connecting wire (on plural units connection) ④ Defective detection of indoor room temperature and pipe <condenser / evaporator> temperature thermistor ⑤ Stop valve is not opened completely.</p>	<p>①-④ Check pipe <liquid or condenser / evaporator> temperature with room temperature display on remote controller and outdoor controller circuit board. Pipe <liquid or condenser / evaporator> temperature display is indicated by setting SW2 of outdoor controller circuit board as follows.</p> <p>(Conduct temperature check with outdoor controller circuit board after connecting 'A-Control Service Tool(PAC-SK52ST)')</p> <p>②③ Check converse connection of extension pipe or converse wiring of indoor/outdoor unit connecting wire.</p>

Error Code	Abnormal point and detection method	Cause	Countermeasure
P9	Pipe temperature thermistor / Condenser-Evaporator (TH5) ① The unit is in 3-minute resume protection mode if short/open of thermistor is detected. Abnormal if the unit does not get back to normal within 3 minutes. (The unit returns to normal operation, if it has been reset normally.) ② Constantly detected during cooling, drying, and heating operation (except defrosting) Short: 90°C (194°F) or more Open: -40°C (-40°F) or less	① Defective thermistor characteristics ② Contact failure of connector (CN29) on the indoor controller board (Insert failure) ③ Breaking of wire or contact failure of thermistor wiring ④ Temperature of thermistor is 90°C (194°F) or more or -40°C (-40°F) or less caused by defective refrigerant circuit. ⑤ Defective indoor controller board	①-③ Check resistance value of thermistor. For characteristics, refer to (P1) above. ② Check contact failure of connector (CN29) on the indoor controller board. Refer to 10-6. Turn the power on and check restart after inserting connector again. ④ Operate in test run mode and check pipe <condenser / evaporator> temperature with outdoor controller circuit board. If pipe <condenser / evaporator> temperature is extremely low (in cooling mode) or high (in heating mode), refrigerant circuit may have defect. ⑤ Operate in test run mode and check pipe <condenser / evaporator> temperature with outdoor control circuit board. If there is exclusive difference with actual pipe <condenser / evaporator> temperature replace indoor controller board. There is no abnormality if none of above comes within the unit. Turn the power off and on again to operate. (In case of checking pipe temperature with outdoor controller circuit board, be sure to connect A-control service tool (PAC-SK52ST).)
E0 or E4	Remote controller transmission error(E0)/signal receiving error(E4) ① Abnormal if main or sub remote controller cannot receive any transmission normally from indoor unit of refrigerant address "0" for 3 minutes. (Error code : E0) ② Abnormal if sub-remote controller could not receive for any signal for 2 minutes. (Error code: E0) ① Abnormal if indoor controller board can not receive any data from remote controller board or normally from other indoor controller board for 3 minutes. (Error code: E4) ② Indoor controller board cannot receive any signal from remote controller for 2 minutes. (Error code: E4)	① Contact failure at transmission wire of remote controller ② All remote controllers are set as "sub" remote controller. In this case, E0 is displayed on remote controller, and E4 is displayed at LED (LED1, LED2) on the outdoor controller circuit board. ③ Miswiring of remote controller ④ Defective transmitting receiving circuit of remote controller ⑤ Defective transmitting receiving circuit of indoor controller board of refrigerant address "0" ⑥ Noise has entered into the transmission wire of remote controller.	① Check disconnection or looseness of indoor unit or transmission wire of remote controller. ② Set one of the remote controllers "main" if there is no problem with the action above. ③ Check wiring of remote controller. • Total wiring length: max. 500m (Do not use cable × 3 or more.) • The number of connecting indoor units: max. 16 units • The number of connecting remote controller: max. 2 units When the above-mentioned problem ①-③ are not seen. ④ Diagnose remote controllers. a) When "RC OK" is displayed, remote controllers have no problem. Turn the power off, and on again to check. If abnormality generates again, replace indoor controller board. b) When "RC NG" is displayed, replace remote controller. c) When "RC E3" is displayed, d) When "ERC 00-06" is displayed, [c),d)→Noise may be causing abnormality.] * If the unit is not normal after replacing indoor controller board in group control, the indoor controller board of address "0" may be abnormal.
E3 or E5	Remote controller transmission error(E3)/signal receiving error(E5) ① Abnormal if remote controller could not find blank of transmission path for 6 seconds and could not transmit. (Error code: E3) ② Remote controller receives transmitted data at the same time, compares the data, and when detecting it, judges different data to be abnormal 30 continuous times. (Error code: E3) ① Abnormal if indoor controller board could not find blank of transmission path. (Error code: E5) ② Indoor controller board receives transmitted data at the same time, compares the data, and when detecting it, judges different data to be abnormal 30 continuous times. (Error code: E5)	① 2 remote controller are set as "main." (In case of 2 remote controllers) ② Remote controller is connected with 2 indoor units or more. ③ Repetition of refrigerant address ④ Defective transmitting receiving circuit of remote controller ⑤ Defective transmitting receiving circuit of indoor controller board ⑥ Noise has entered into transmission wire of remote controller.	① Set a remote controller to main, and the other to sub. ② Remote controller is connected with only 1 indoor unit. ③ The address changes to a separate setting. ④-⑥ Diagnose remote controller. a) When "RC OK" is displayed, remote controllers have no problem. Turn the power off, and on again to check. When becoming abnormal again, replace indoor controller board. b) When "RC NG" is displayed, replace remote controller. c) When "RC E3" or "ERC 00-66" is displayed, noise may be causing abnormality.

Error Code	Abnormal point and detection method	Cause	Countermeasure
E6	<p>Indoor/outdoor unit communication error (Signal receiving error)</p> <p>① Abnormal if indoor controller board cannot receive any signal normally for 6 minutes after turning the power on.</p> <p>② Abnormal if indoor controller board cannot receive any signal normally for 3 minutes.</p> <p>③ Consider the unit as abnormal under the following condition: When 2 or more indoor units are connected to 1 outdoor unit, indoor controller board cannot receive a signal for 3 minutes from outdoor controller circuit board, a signal which allows outdoor controller circuit board to transmit signals.</p>	<p>① Contact failure, short circuit or, miswiring (converse wiring) of indoor/outdoor unit connecting wire</p> <p>② Defective transmitting receiving circuit of indoor controller board</p> <p>③ Defective transmitting receiving circuit of indoor controller board</p> <p>④ Noise has entered into indoor/outdoor unit connecting wire.</p>	<p>* Check LED display on the outdoor control circuit board. (Connect A-control service tool, PAC-SK52ST.) For EA-EC item, refer to outdoor unit service manual.</p> <p>① Check disconnection or looseness of indoor/outdoor unit connecting wire of indoor unit or outdoor unit. Check all the units in case of twin indoor unit system.</p> <p>②-④ Turn the power off, and on again to check. If abnormality generates again, replace indoor controller board or outdoor controller circuit board.</p> <p>* Other indoor controller board may have defect in case of twin indoor unit system.</p>
E7	<p>Indoor/outdoor unit communication error (Transmitting error)</p> <p>Abnormal if "1" receiving is detected 30 times continuously though indoor controller board has transmitted "0".</p>	<p>① Defective transmitting receiving circuit of indoor controller board</p> <p>② Noise has entered into power supply.</p> <p>③ Noise has entered into outdoor control wire.</p>	<p>①-③ Turn the power off, and on again to check. If abnormality generates again, replace indoor controller board.</p>
Fb	<p>Indoor controller board</p> <p>Abnormal if data cannot be normally read from the nonvolatile memory of the indoor controller board.</p>	<p>① Defective indoor controller board</p>	<p>① Replace indoor controller board.</p>
E1 or E2	<p>Remote controller control board</p> <p>① Abnormal if data cannot be normally read from the nonvolatile memory of the remote controller control board. (Error code: E1)</p> <p>② Abnormal if the clock function of remote controller cannot be normally operated. (Error code: E2)</p>	<p>① Defective remote controller</p>	<p>① Replace remote controller.</p>
PA (2502) (2500)	<p>Forced compressor stop (due to water leakage abnormality)</p> <p>① When the intake temperature subtracted with liquid pipe temperature is less than -10°C (14°F), drain sensor detects whether it is soaked in the water or not at the interval of 90 seconds. (Drain pump will start operating when the drain sensor detects to be soaked in the water.)</p> <p>② The unit has a water leakage abnormality when the following conditions, a) and b), are satisfied while the above-mentioned detection is performed.</p> <p>a) The drain sensor detects to be soaked in the water 10 times in a row.</p> <p>b) The intake temperature subtracted with liquid pipe temperature is detected to be less than -10°C (14°F) for a total of 30 minutes. (When the drain sensor detects to be NOT soaked in the water, the detection record of a and b will be cleared.)</p> <p>③ The drain sensor detection is performed in operations other than cooling. (When the unit stops operating, during heating or fan operation, when the unit stops because of some abnormality)</p> <p>*Once the water leakage abnormality is detected, abnormality state will not be released until the main power is reset.</p>	<p>① Drain pump trouble</p> <p>② Drain defective</p> <ul style="list-style-type: none"> · Drain pump clogging · Drain pipe clogging <p>③ Open circuit of drain sensor side heater</p> <p>④ Contact failure of drain sensor connector</p> <p>⑤ Dew condensation on drain sensor</p> <ul style="list-style-type: none"> · Drain water trickles along lead wire. · Drain water waving due to filter clogging <p>⑥ Extension piping connection difference at twin system</p> <p>⑦ Miswiring of indoor/ outdoor connecting at twin system</p> <p>⑧ Room temperature thermistor / liquid pipe temperature thermistor detection is defective.</p>	<p>① Check the drain pump.</p> <p>② Check whether water can be drained.</p> <p>③ Check the resistance of the drain sensor.</p> <p>④ Check the connector contact failure.</p> <p>⑤ Check the drain sensor leadwire mounted. Check the filter clogging.</p> <p>⑥ Check the piping connection.</p> <p>⑦ Check the indoor/ outdoor connecting wires.</p> <p>⑧ Check the room temperature display of remote controller. Check the indoor liquid pipe temperature display of outdoor controller board.</p>

10-3. TROUBLESHOOTING BY INFERIOR PHENOMENA

Note: Refer to the manual of outdoor unit for the detail of remote controller.

Phenomena	Cause	Countermeasure
<p>(1)LED2 on indoor controller board is off.</p>	<ul style="list-style-type: none"> • When LED1 on indoor controller board is also off. ① Power supply of rated voltage is not supplied to outdoor unit. ② Defective outdoor controller circuit board ③ Power supply of 208/230V is not supplied to indoor unit. ④ Defective indoor power board ⑤ Defective indoor controller board <p>(For the separate indoor/outdoor unit power supply system)</p> <ul style="list-style-type: none"> ① Power supply of 208/230V AC is not supplied to indoor unit. ② The connectors of the optional replacement kit are not used. ③ Defective indoor controller board ④ Defective indoor power board 	<ul style="list-style-type: none"> ① Check the voltage of outdoor power supply terminal block (L1,L2). <ul style="list-style-type: none"> • When AC 208/230V is not detected, check the power wiring to outdoor unit and the breaker. • When AC 208/230V is detected, check ② (below). ② Check the voltage between outdoor terminal block S1 and S2. <ul style="list-style-type: none"> • When AC 208/230V is not detected, —check the fuse on outdoor controller circuit board. —check the wiring connection. • When AC 208/230V is detected, check ③ (below). ③ Check the voltage between indoor terminal block S1 and S2. <ul style="list-style-type: none"> • When AC 208/230V is not detected, check indoor/outdoor unit connecting wire for miswiring. • When AC 208/230V is detected, check ④ (below). ④ Check voltage output from CN2S on indoor power board (DC13.1V). Refer to 10-6-1. <ul style="list-style-type: none"> • When no voltage is output, check the wiring connection. • When output voltage is between DC12.5V and DC13.7V, check ⑤ (below). ⑤ Check the wiring connection between indoor controller board and indoor power board. Check the fuse on indoor controller board. If no problems are found, indoor controller board is defective. <ul style="list-style-type: none"> ① Check the voltage of indoor power supply terminal block (L1,L2). <ul style="list-style-type: none"> • When AC208/230V is not detected, check the power supply wiring. • When AC208/230V is detected, check ② (below). ② Check that there is no problem in the method of connecting the connectors. <ul style="list-style-type: none"> • When there are problems in the method of connecting the connectors, connect the connector correctly referring to installation manual of an optional kit. • When there is no problem in the method of connecting the connectors, check ③ (below). ③ Check voltage output from CNDK on indoor controller board. <ul style="list-style-type: none"> • When AC208/230V is not detected, —check the fuse on indoor controller board. —check the wiring connection between indoor power supply terminal block and CND on indoor controller board. • When AC208/230V is detected, check ④ (below). ④ Check voltage output from CN2S on indoor power board. <ul style="list-style-type: none"> • When no voltage output, check the wiring connection between CNDK on indoor controller board and CNSK on indoor power board. If no problem are found, indoor power board is defective. • When DC12.5–13.7V is detected, check the wiring connection between CN2S on indoor power board and CN2D on indoor power board. If no problem are found, indoor controller board is defective.

Note: Refer to the manual of the outdoor unit for the detail of remote controller.

Phenomena	Cause	Countermeasure
(1)LED2 on indoor controller board is off.	<ul style="list-style-type: none"> When LED1 on indoor controller board is lit. ① Mis-setting of refrigerant address for outdoor unit (There is no unit corresponding to refrigerant address "0".)	① Reconfirm the setting of refrigerant address for outdoor unit. Set the refrigerant address to "0". (For grouping control system under which 2 or more outdoor units are connected, set one of the units to "0".) Set refrigerant address using SW1 (3-6) on outdoor controller circuit board.
(2)LED2 on indoor controller board is blinking.	<ul style="list-style-type: none"> When LED1 on indoor controller board is also blinking. Connection failure of indoor/outdoor unit connecting wire	Check indoor/outdoor unit connecting wire for connection failure.
	<ul style="list-style-type: none"> When LED1 is lit. ① Miswiring of remote controller wires Under indoor unit system, 2 indoor units are wired together. ② Refrigerant address for outdoor unit is wrong or not set. Under grouping control system, there are some units whose refrigerant address is 0. ③ Shortcut of remote controller wires ④ Defective remote controller	① Check the connection of remote controller wires in case of twin indoor unit system. When 2 or more indoor units are wired in one refrigerant system, connect remote controller wires to one of those units. ② Check the setting of refrigerant address in case of grouping control system. If there are some units whose refrigerant addresses are 0 in one group, set one of the units to 0 using SW1 (3-6) on outdoor controller circuit board. ③④ Remove remote controller wires and check LED2 on indoor controller board. <ul style="list-style-type: none"> When LED2 is blinking, check the shortcut of remote controller wires. When LED2 is lit, connect remote controller wires again and: if LED2 is blinking, remote controller is defective; if LED2 is lit, connection failure of remote controller terminal block etc. has returned to normal.
(3)Upward/downward vane performance failure	① The vane is not downward during defrosting and heat preparation and when the thermostat is OFF in HEAT mode. (Working of COOL protection function) ② Vane motor does not rotate. <ul style="list-style-type: none"> Defective vane motor Breaking of wire or connection failure of connector Up/downward vane setting is "No vanes". ③ Upward/downward vane does not work. <ul style="list-style-type: none"> The vane is set to fixed position. 	① Normal operation (The vane is set to horizontal regardless of remote control.) ② Check ② (left). <ul style="list-style-type: none"> Check the vane motor. (Refer to "How to check the parts".) Check for breaking of wire or connection failure of connector. Check "Up/down vane setting". (Unit function selection by remote controller). ③ Normal operation (Each connector on vane motor side is disconnected.)
(4)Receiver for wireless remote controller	① Weak batteries of wireless remote controller ② Contact failure of connector (CNB) on wireless remote controller board(Insert failure) ③ Contact failure of connector (CN90) on indoor controller board(Insert failure) ④ Contact failure of connector between wireless remote controller board and indoor controller board	① Replace batteries of the wireless remote controller. ②-④ Check contact failure of each connector. If no problems are found in connector, replace indoor controller board. When the same trouble occurs even if indoor controller board is replaced, replace wireless remote controller board.

10-4. WHEN WIRED REMOTE CONTROLLER OR INDOOR UNIT MICROCOMPUTER TROUBLES

- If there is not any other problem when trouble occurs, emergency operation starts as the indoor controller board switch (SWE) is set to ON.
During the emergency operation the indoor unit operates with Indoor fan at high speed.
- For emergency operation of cooling or heating
In emergency operation for COOL or HEAT, setting of the switch (SWE) in the indoor controller board and outdoor unit emergency operation are necessary.

3. Before you activate emergency operation, check the following points:

- (1) Emergency operation cannot be activated when:
 - the outdoor unit malfunctions.
 - the indoor fan malfunctions.
- (2) Emergency operation becomes continuous only by switching the power source on / off. ON / OFF on the remote control or temperature control etc. does not function.
- (3) Avoid operating for a long time when the outdoor unit begins defrosting while emergency operation of the heating is activated, because it will start to blow cold air.
- (4) Emergency cooling should be limited to 10 hours maximum. (The indoor unit heat exchanger may freeze.)
- (5) After emergency operation has been deactivated, set the switches etc. to their original positions.
- (6) Movement of the vanes does not work in emergency operation, therefore you have to slowly set them manually to the appropriate position.

10-5. HOW TO CHECK THE PARTS

PCA-A24GA PCA-A30GA PCA-A36GA PCA-A42GA
PCA-A24GA₁ PCA-A30GA₁ PCA-A36GA₁ PCA-A42GA₁
PCA-A24GA₂ PCA-A30GA₂ PCA-A36GA₂ PCA-A42GA₂

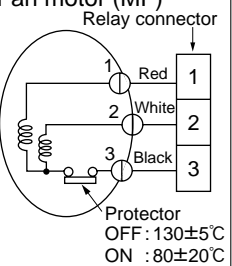
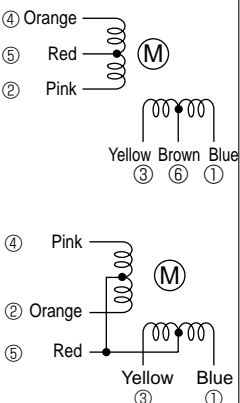
Parts name	Check points																				
Room temperature thermistor (TH1) Pipe temperature thermistor (TH2) Condenser/evaporator temperature thermistor (TH5)	Disconnect the connector then measure the resistance with a tester. (At the ambient temperature 10°C (50°F)~30°C (86°F)) <table border="1" style="margin-left: 20px;"> <tr> <td>Normal</td> <td>Abnormal</td> </tr> <tr> <td>4.3kΩ~9.6kΩ</td> <td>Open or short</td> </tr> </table> (Refer to Thermistor Characteristic graph.)	Normal	Abnormal	4.3kΩ~9.6kΩ	Open or short																
Normal	Abnormal																				
4.3kΩ~9.6kΩ	Open or short																				
Fan motor (MF) 	Measure the resistance between the terminals with a tester. (Winding temperature 20°C (68°F)) <table border="1" style="margin-left: 20px;"> <tr> <th rowspan="2">Motor terminal or Relay connector</th> <th colspan="2">Normal</th> <th rowspan="2">Abnormal</th> </tr> <tr> <td>PCA-A24GA₍₁₎₍₂₎ PCA-A30GA₍₁₎₍₂₎</td> <td>PCA-A36GA₍₁₎₍₂₎ PCA-A42GA₍₁₎₍₂₎</td> </tr> <tr> <td>Red-Black</td> <td>60.8Ω</td> <td>41.1Ω</td> <td rowspan="2">Open or short</td> </tr> <tr> <td>White-Black</td> <td>55.1Ω</td> <td>54.3Ω</td> </tr> </table>	Motor terminal or Relay connector	Normal		Abnormal	PCA-A24GA ₍₁₎₍₂₎ PCA-A30GA ₍₁₎₍₂₎	PCA-A36GA ₍₁₎₍₂₎ PCA-A42GA ₍₁₎₍₂₎	Red-Black	60.8Ω	41.1Ω	Open or short	White-Black	55.1Ω	54.3Ω							
Motor terminal or Relay connector	Normal		Abnormal																		
	PCA-A24GA ₍₁₎₍₂₎ PCA-A30GA ₍₁₎₍₂₎	PCA-A36GA ₍₁₎₍₂₎ PCA-A42GA ₍₁₎₍₂₎																			
Red-Black	60.8Ω	41.1Ω	Open or short																		
White-Black	55.1Ω	54.3Ω																			
Vane motor (MV) 	<table border="1" style="margin-left: 20px;"> <tr> <th rowspan="2">Connector</th> <th>Normal</th> <th rowspan="2">Abnormal</th> </tr> <tr> <td>PCA-A24·30GA₍₁₎₍₂₎</td> </tr> <tr> <td>Brown-Yellow</td> <td rowspan="4">140~160Ω</td> <td rowspan="4">Open or short</td> </tr> <tr> <td>Brown-Blue</td> </tr> <tr> <td>Red-Orange</td> </tr> <tr> <td>Red-Pink</td> </tr> </table> <table border="1" style="margin-left: 20px;"> <tr> <th rowspan="2">Connector</th> <th>Normal</th> <th rowspan="2">Abnormal</th> </tr> <tr> <td>PCA-A36·42GA₍₁₎₍₂₎</td> </tr> <tr> <td>Red-Yellow</td> <td rowspan="4">140~160Ω</td> <td rowspan="4">Open or short</td> </tr> <tr> <td>Red-Blue</td> </tr> <tr> <td>Red-Blue</td> </tr> <tr> <td>Red-Pink</td> </tr> </table>	Connector	Normal	Abnormal	PCA-A24·30GA ₍₁₎₍₂₎	Brown-Yellow	140~160Ω	Open or short	Brown-Blue	Red-Orange	Red-Pink	Connector	Normal	Abnormal	PCA-A36·42GA ₍₁₎₍₂₎	Red-Yellow	140~160Ω	Open or short	Red-Blue	Red-Blue	Red-Pink
Connector	Normal		Abnormal																		
	PCA-A24·30GA ₍₁₎₍₂₎																				
Brown-Yellow	140~160Ω	Open or short																			
Brown-Blue																					
Red-Orange																					
Red-Pink																					
Connector	Normal	Abnormal																			
	PCA-A36·42GA ₍₁₎₍₂₎																				
Red-Yellow	140~160Ω	Open or short																			
Red-Blue																					
Red-Blue																					
Red-Pink																					

<Thermistor Characteristic graph>

Thermistor for lower temperature

Room temperature thermistor (TH1)
 Pipe temperature thermistor (TH2)
 Condenser/evaporator temperature thermistor (TH5)

Thermistor $R_0=15k\Omega \pm 3\%$
 Fixed number of $B=3480 \pm 2\%$

$$t(^{\circ}C):R_t=15\exp\left\{3480\left(\frac{1}{273+t}-\frac{1}{273}\right)\right\}$$

$$T(^{\circ}F):R_t=15\exp\left\{3480\left(\frac{1}{273+\frac{T-32}{1.8}}-\frac{1}{273}\right)\right\}$$

0°C (32°F)	15kΩ
10°C (50°F)	9.6kΩ
20°C (68°F)	6.3kΩ
25°C (77°F)	5.4kΩ
30°C (86°F)	4.3kΩ
40°C (104°F)	3.0kΩ

< Thermistor for lower temperature >

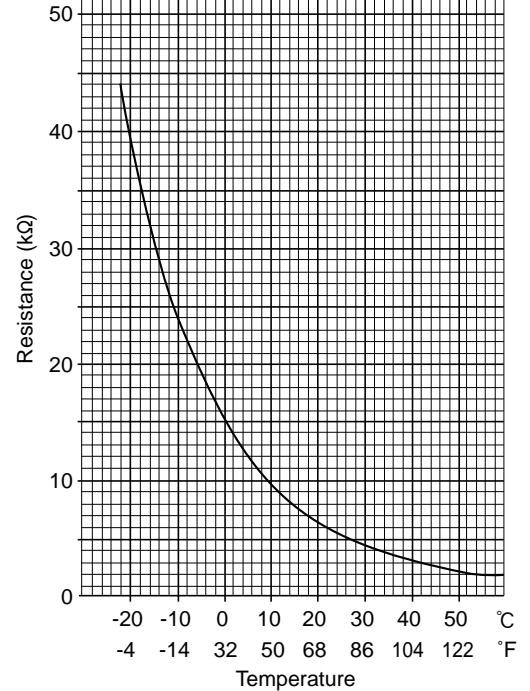

10-6. TEST POINT DIAGRAM

10-6-1. Power board

- | | | | |
|------------------------|------------------------|------------------------|------------------------|
| PCA-A24GA | PCA-A30GA | PCA-A36GA | PCA-A42GA |
| PCA-A24GA ₁ | PCA-A30GA ₁ | PCA-A36GA ₁ | PCA-A42GA ₁ |
| PCA-A24GA ₂ | PCA-A30GA ₂ | PCA-A36GA ₂ | PCA-A42GA ₂ |

CN2S
 Connect to the indoor controller board (CN2D)
 Between ① to ③ 12.6-13.7V DC (Pin① (+))

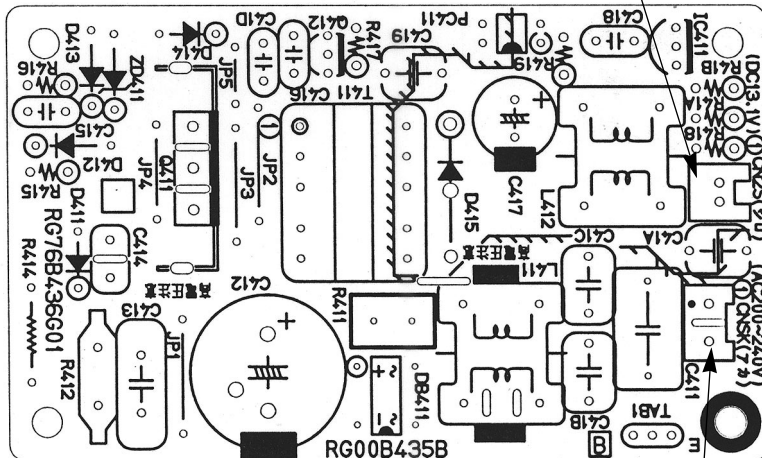

CNSK
 Connect to the indoor controller board (CNDK)
 Between ① to ③ 208/230V AC

10-6-2. Indoor controller board

- | | | | |
|------------------------|------------------------|------------------------|------------------------|
| PCA-A24GA | PCA-A30GA | PCA-A36GA | PCA-A42GA |
| PCA-A24GA ₁ | PCA-A30GA ₁ | PCA-A36GA ₁ | PCA-A42GA ₁ |
| PCA-A24GA ₂ | PCA-A30GA ₂ | PCA-A36GA ₂ | PCA-A42GA ₂ |

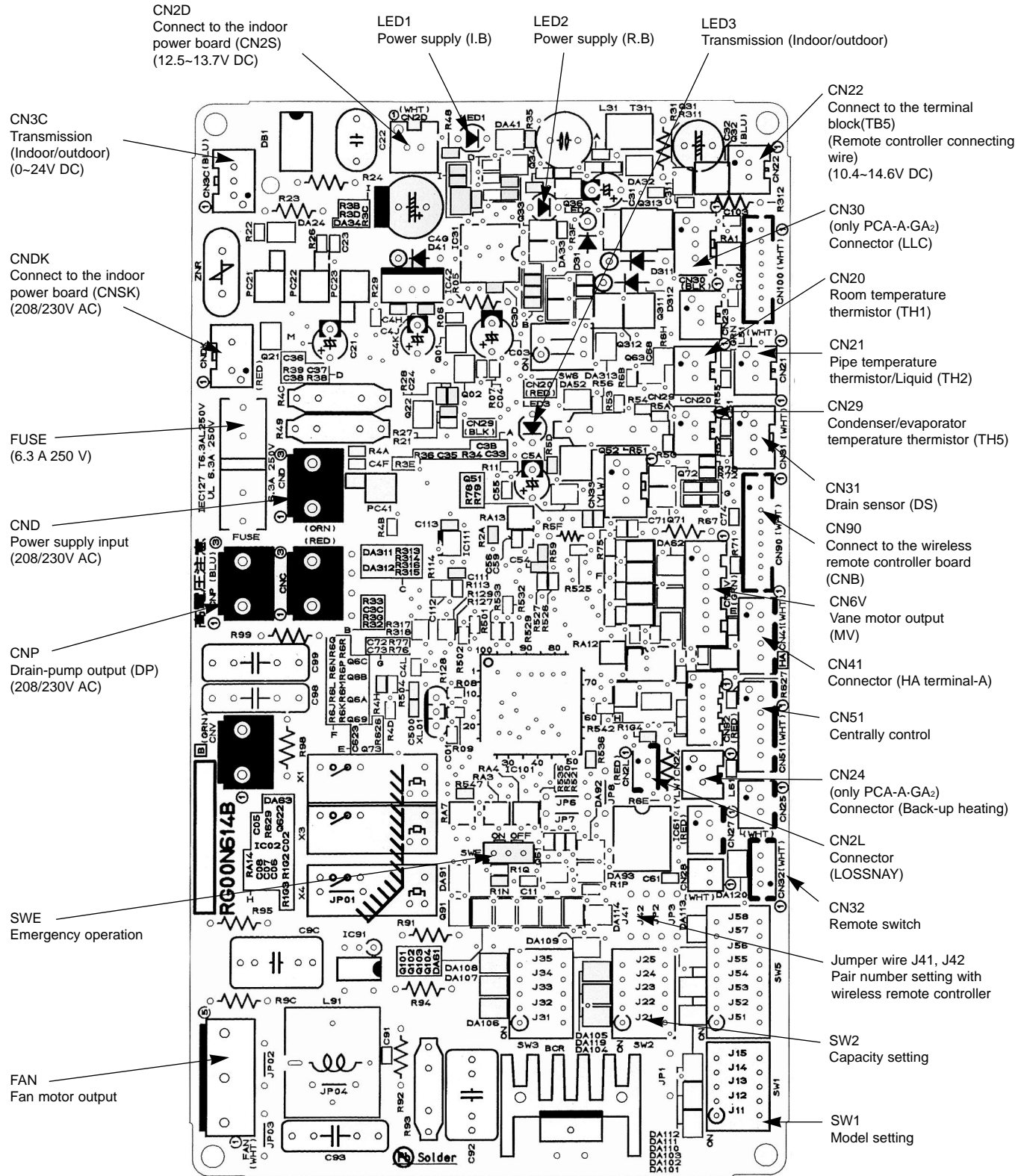











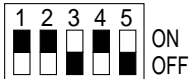

10-7. FUNCTIONS OF DIP SWITCH AND JUMPER WIRE

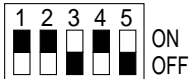
Each function is controlled by the dip switch and the jumper wire on control P.C. board.

SW1 and SW2 are equipped only for service parts.

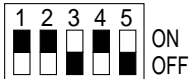
Model setting and capacity setting are memorized in the nonvolatile memory of the control P.C. board of the unit.

(Marks in the table below) Jumper wire (○ : Short × : Open)

Jumper wire	Functions	Setting by the dip switch and jumper wire	Remarks																	
SW1	Model settings	For service board 																		
SW2	Capacity settings	<table border="1"> <thead> <tr> <th>MODELS</th> <th>Service board</th> </tr> </thead> <tbody> <tr> <td>PCA-A24GA PCA-A24GA₁ PCA-A24GA₂</td> <td>  </td> </tr> <tr> <td>PCA-A30GA PCA-A30GA₁ PCA-A30GA₂</td> <td>  </td> </tr> <tr> <td>PCA-A36GA PCA-A36GA₁ PCA-A36GA₂</td> <td>  </td> </tr> <tr> <td>PCA-A42GA PCA-A42GA₁ PCA-A42GA₂</td> <td>  </td> </tr> </tbody> </table>	MODELS	Service board	PCA-A24GA PCA-A24GA ₁ PCA-A24GA ₂		PCA-A30GA PCA-A30GA ₁ PCA-A30GA ₂		PCA-A36GA PCA-A36GA ₁ PCA-A36GA ₂		PCA-A42GA PCA-A42GA ₁ PCA-A42GA ₂									
MODELS	Service board																			
PCA-A24GA PCA-A24GA ₁ PCA-A24GA ₂																				
PCA-A30GA PCA-A30GA ₁ PCA-A30GA ₂																				
PCA-A36GA PCA-A36GA ₁ PCA-A36GA ₂																				
PCA-A42GA PCA-A42GA ₁ PCA-A42GA ₂																				
J41 J42	Pair number setting with wireless remote controller	<table border="1"> <thead> <tr> <th rowspan="2">Wireless remote controller setting</th> <th colspan="2">Control PCB setting</th> </tr> <tr> <th>J41</th> <th>J42</th> </tr> </thead> <tbody> <tr> <td>0</td> <td>○</td> <td>○</td> </tr> <tr> <td>1</td> <td>×</td> <td>○</td> </tr> <tr> <td>2</td> <td>○</td> <td>×</td> </tr> <tr> <td>3 ~ 9</td> <td>×</td> <td>×</td> </tr> </tbody> </table>	Wireless remote controller setting	Control PCB setting		J41	J42	0	○	○	1	×	○	2	○	×	3 ~ 9	×	×	<p><Initial setting> Wireless remote controller: 0 Control PCB: ○ (for both J41 and J42) Four pair number settings are supported. The pair number settings of the wireless remote controller and indoor control PCB (J41/J42) are given in the table on the left. ('×' in the table indicates the jumper wire is disconnected.)</p>
Wireless remote controller setting	Control PCB setting																			
	J41	J42																		
0	○	○																		
1	×	○																		
2	○	×																		
3 ~ 9	×	×																		
JP1	Unit type setting	<table border="1"> <thead> <tr> <th>Model</th> <th>JP1</th> </tr> </thead> <tbody> <tr> <td>Without TH5</td> <td>○</td> </tr> <tr> <td>With TH5</td> <td>×</td> </tr> </tbody> </table>	Model	JP1	Without TH5	○	With TH5	×	There is no jumper (JP1) because these models have the cond./eva. temperature thermistor (TH5).											
Model	JP1																			
Without TH5	○																			
With TH5	×																			
JP3	Indoor controller board type setting	<table border="1"> <thead> <tr> <th>Indoor controller board type</th> <th>JP3</th> </tr> </thead> <tbody> <tr> <td>For product</td> <td>×</td> </tr> <tr> <td>Service parts</td> <td>○</td> </tr> </tbody> </table>	Indoor controller board type	JP3	For product	×	Service parts	○												
Indoor controller board type	JP3																			
For product	×																			
Service parts	○																			

11-1. ROTATION FUNCTION(AND BACK-UP FUNCTION, 2ND STAGE CUT-IN FUNCTION)

11-1-1. OPERATION

(1) Rotation function(and Back-up function)

Outline of functions

- Operating the unit of main and sub alternately according to the interval setting. (Rotation function)
- ※The setting of main/sub unit depends on the refrigerant address.(The setting of dip switch on the outdoor unit)
- Refrigerant address"00" → Main unit
- Refrigerant address"01" → Sub unit
- If an error occurs to one unit, the other unit starts.(Back-up function)

System constraint

- This function is available only by the grouping control system(INDOOR UNIT : OUTDOOR UNIT=1:1) of 2 refrigerant group.(Refer to Fig 1)
- It is necessary to connect remote controller crossover wiring to between units(Wireless remote controller is unusable) and to assign refrigerant address to each unit.(Dip switch on the outdoor unit...Refrigerant address 00/01)

Operation pattern

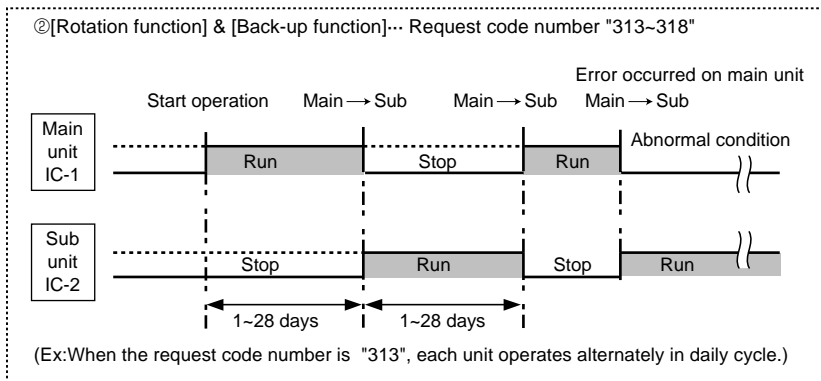
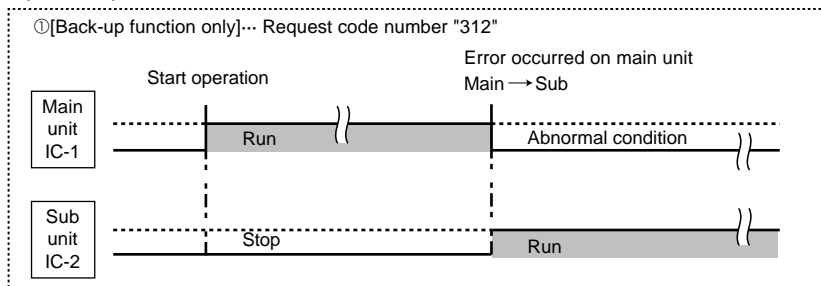
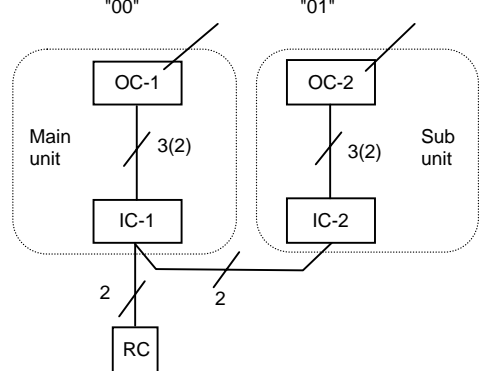

Fig 1 Refrigerant address "00" Refrigerant address "01"



OC: Outdoor unit
IC: Indoor unit
RC: Wired remote controller

(2) 2nd stage cut-in function

Outline of functions

- Quantity of operating units is controlled according to the room temperature and set point.
- When room temperature becomes more than set point, standby unit starts.(2 units running)
- When room temperature falls below set point -4°C (7.5°F), standby unit stops.(1 unit running)

System constraint

- This function is available only in rotation operation(or back-up) and cooling mode.

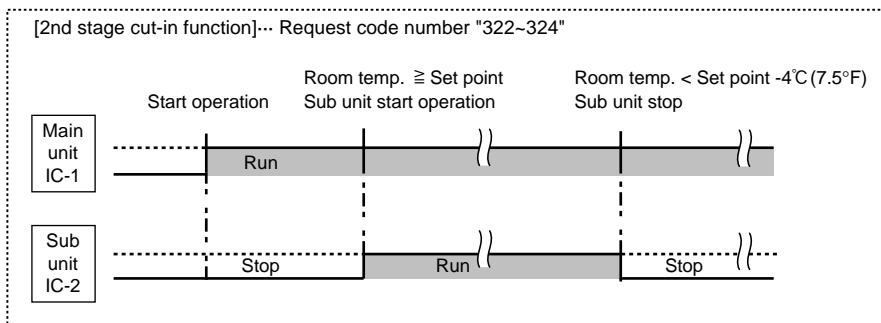

11-1-2.HOW TO PERFORM THE OPERATION OF ROTATION FUNCTION(BACK-UP FUNCTION, 2ND STAGE CUT-IN FUNCTION)

Set by wired remote controller.(Maintenance monitor)

NOTICE

It is necessary to set the same content to both main unit and sub unit.
Every time indoor controller board is replaced for servicing, it is necessary to set each function.

(1) Request Code List

Rotation setting

Setting No. (Request code)	Setting contents	Initial setting
No.1 (310)	Monitoring the request code of current setting.	
No.2 (311)	Rotation and Back-up OFF (Normal group control operation)	☉
No.3 (312)	Back-up function only	
No.4 (313)	Rotation ON (Alternating interval = 1day) and back-up function	
No.5 (314)	Rotation ON (Alternating interval = 3days) and back-up function	
No.6 (315)	Rotation ON (Alternating interval = 5days) and back-up function	
No.7 (316)	Rotation ON (Alternating interval = 7days) and back-up function	
No.8 (317)	Rotation ON (Alternating interval = 14days) and back-up function	
No.9 (318)	Rotation ON (Alternating interval = 28days) and back-up function	

2nd stage cut-in setting

Setting No. (Request code)	Setting contents	Initial setting
No.1 (320)	Monitoring the request code of current setting.	
No.2 (321)	Cut-in function OFF	☉
No.3 (322)	Cut-in function ON (Set point = Set temp. +4°C (7.2°F))	
No.4 (323)	Cut-in function ON (Set point = Set temp. +6°C (10.8°F))	
No.5 (324)	Cut-in function ON (Set point = Set temp. +8°C (14.4°F))	

(2) Setting method of each function by wired remote controller

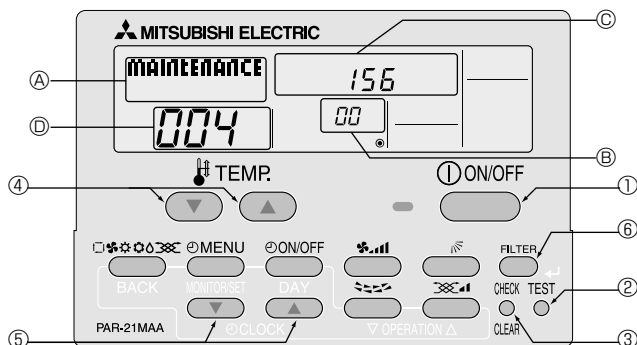

B: Refrigerant address
C: Data display area
D: Request code display area

1. Stop running the air-conditioner(①).
2. Press the **TEST** button (②) for 3 seconds so that [Maintenance mode] appears on the screen (at ④).
→ After a while, [00] appears in the refrigerant address number display area.(at ⑤)
3. Press the **CHECK** button (③) for 3 seconds to switch to [Maintenance monitor].
Note) It is not possible to switch to [Maintenance monitor] during data request in maintenance mode (i.e., while“----” is blinking) since no buttons are operative.

[---] appears on the screen (at ⑤) when [Maintenance monitor] is activated.
(The display (at ⑤) now allows you to set a request code No.)
4. Press the [TEMP (▽ and △)] buttons (④) to select the desired refrigerant address.

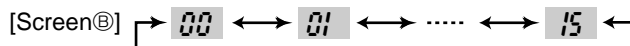

5. Press the [CLOCK (▽ and △)] buttons (⑤) to set the desired request code No.(“311~318”, “321~324”, “331~335”)
6. Press the **FILTER** button (⑥) to perform function setting.
→ If the above operations are set correctly, request code number will appear in data display area.(at ④)
[Example] When the request code number is "311", [311] appears on the screen.(at ④)]

[Reference]

You can check the request code number of current setting by setting the request code number (“310”, “320” or “330”) and press the **FILTER** button.(⑥)

[Example] When the current setting is "Setting No.2(Request code 311)", [311] appears on the screen.(at ④)]

7. To return to normal mode, press the **ON/OFF** button (①).

11-2. BACK-UP HEATING FUNCTION(CN24)

11-2-1. OPERATION

Outline of functions

The back-up heater signal is sent out according to the temperature difference between indoor room temperature and set temperature. This function is available only in heating operation.

11-2-2. HOW TO CONNECT

When connecting to the connector CN24 of the indoor unit, use PAC-SE56RA-E(optional parts).

	Temperature difference (Z=Set temp. - Room temp.)	Back-up heater signal output
1	$Z \leq 0^{\circ}\text{C} (^{\circ}\text{F})$	OFF
2	$0 < Z < 2.5^{\circ}\text{C} (4.5^{\circ}\text{F})$	Keeping condition
3	$2.5^{\circ}\text{C} (4.5^{\circ}\text{F}) \leq Z$	ON

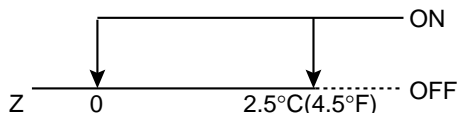

PCA-A24GA

PCA-A30GA

PCA-A36GA

PCA-A42GA

PCA-A24GA₁PCA-A30GA₁PCA-A36GA₁PCA-A42GA₁PCA-A24GA₂PCA-A30GA₂PCA-A36GA₂PCA-A42GA₂

OPERATING PROCEDURE

1. Removing the air intake grille

- (1) Slide the intake grille holding 2 knobs backward to open the intake grille.
- (2) When the intake grille left open, push the stoppers on the rear 2 hinges to pull out the intake grille.

PHOTOS & ILLUSTRATIONS

Figure 1

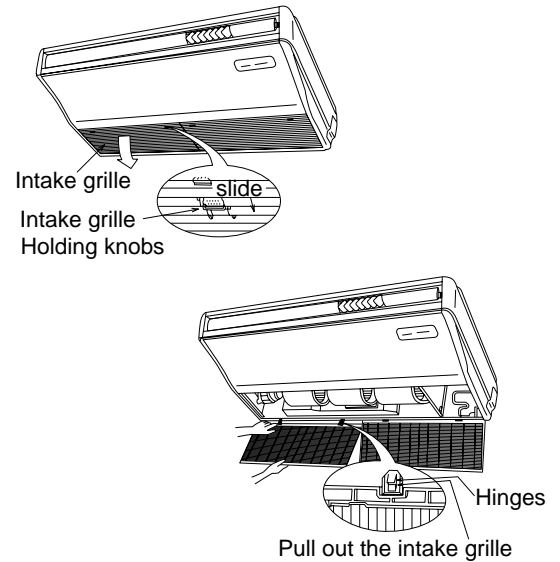
**2. Removing the electrical box**

- (1) Remove the air intake grille. (See the figure 1)
- (2) Remove the screw from the beam and remove the beam.
- (3) Remove the screws from the electrical cover, and remove the electrical cover.
- (4) Disconnect CN6V, CN21 and CN29.
- (5) Remove the screws from the electrical box and pull out the electrical box.

<Electrical parts in the electrical box>

Terminal block (for indoor / outdoor connecting line)<TB4>

Terminal block (for power supply)<TB2>

Terminal block (for remote controller)<TB5>

Fan motor capacitor<C>

Indoor control board<I.B>

Power board<P.B>

(There might not be TB2 depending on the model.)

Figure 2

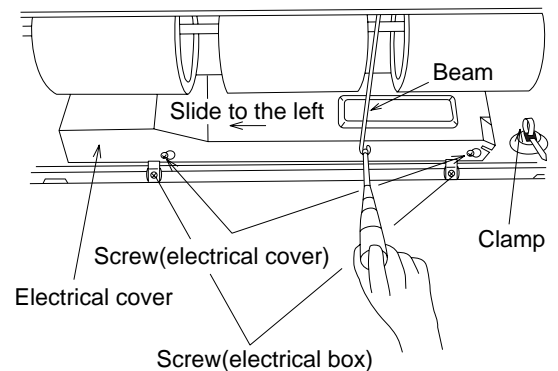
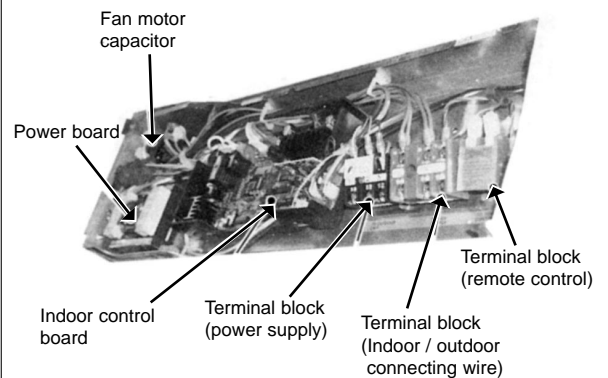

Photo 1



OPERATING PROCEDURE

PHOTOS & ILLUSTRATIONS

3. Removing the fan motor <MF>

- (1) Remove the intake grille.
- (2) Disconnect the fan motor connector.
- (3) Remove the screw for removing the motor support at both left and right side.
- (4) Loosen the set screws at the fan motor side of the connecting joint.
- (5) Slide the fan motor <MF> to the left side and pull it out.

Photo 2

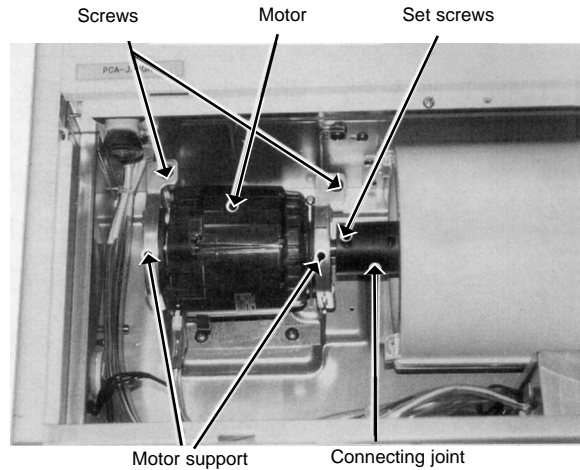

4. Removing the sirocco fan

- (1) Remove the air intake grille.
- (2) Remove 1 beam.
- (3) Remove the lower casing while pressing the stoppers at upper side of the casing.
- (4) Loosen the set screws at the connecting joint.
- (5) Remove the sirocco fan and shaft together by sliding the shaft to the left.

(Note)

Make sure that the upper side casing is snapped to the fan plate securely with catch.

Photo 3

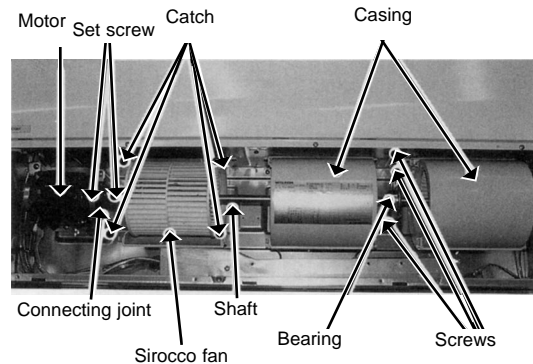

5. Removing the side panel

- (1) Remove the air intake grille.
- (2) Remove the screw from the side panel, and remove the side panel by sliding the panel to the front.

Figure 3

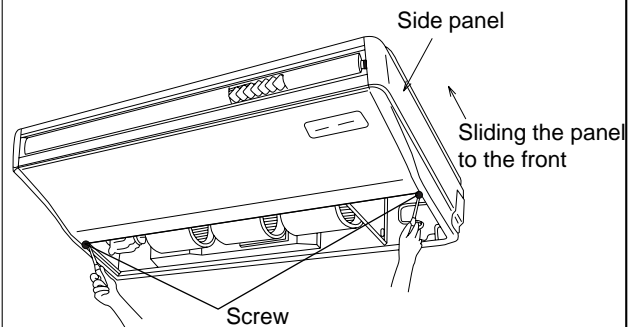

OPERATING PROCEDURE

6. Removing the vane motor <MV>

- (1) Remove the air intake grille. (See the figure 1)
- (2) Remove the left side panel. (See the figure 3)
- (3) Remove the relay connector of vane motor.
- (4) Remove the electrical box.
- (5) Remove the screws of vane motor, then remove vane motor <MV>.

(Note)

Connect the lead wires and connectors properly and place them in the proper position so that the wires are not pinched by other parts.

7. Removing the Indoor coil thermistor <TH2/TH5>

- (1) Remove the air intake grille. (See the figure 1)
- (2) Remove the right side panel. (See the figure 3)
- (3) Remove the relay connector of the pipe thermistor <TH2/TH5>.
- (4) Remove the screw, and remove the check panel.
- (5) Extract the indoor coil thermistor <TH2/TH5> from the holder.

<Caution for the installation>

There is a possibility for the short circuit when connector gets wet by water through the thermistor lead wire. Therefore, lead wire of the indoor coil thermistor <TH2/TH5> should be tied as shown in the photo 6.

8. Removing the Under panel

- (1) Remove the air intake grille. (See the figure 1)
- (2) Remove the beam.
- (3) Remove the side panel (right and left). (See the figure 3)
- (4) Remove the 9 screws of the under panel, then remove the under panel.

* Weight of the under panel : Approx. 2kg.

PHOTOS

Photo 4

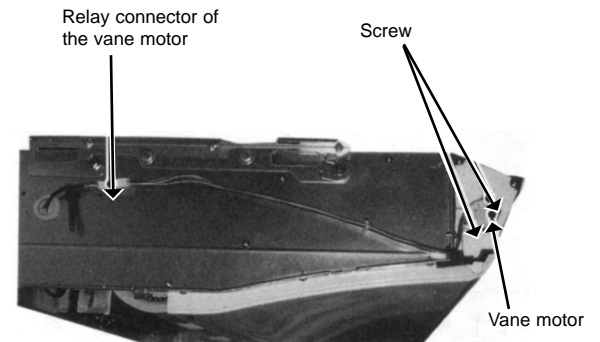

Photo 5

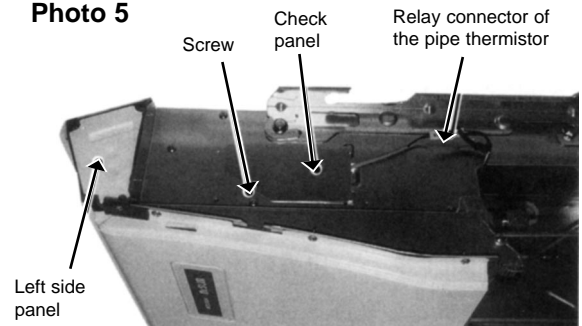

Photo 6

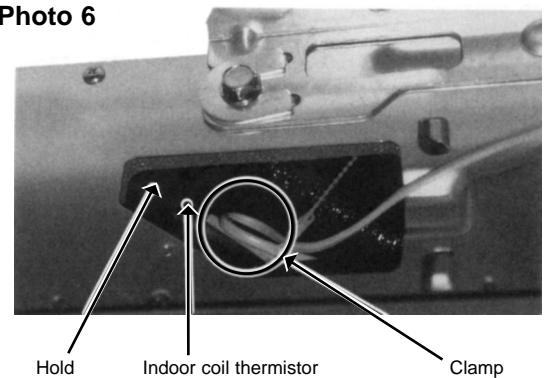
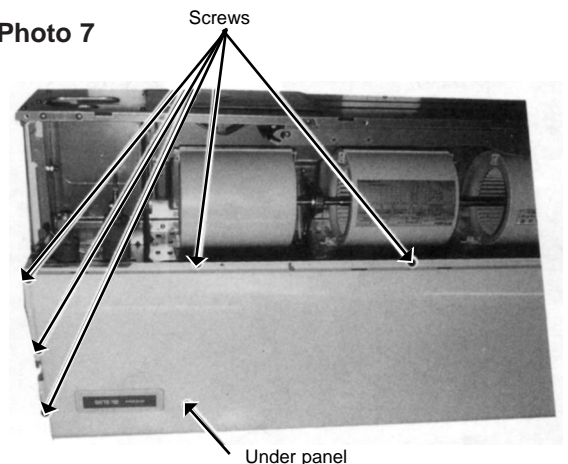

Photo 7



OPERATING PROCEDURE

9. Removing the drain pan

- (1) Remove the air intake grille. (See the figure 1)
- (2) Remove the beam.
- (3) Remove the side panels of right and left. (See the figure 3)
- (4) Remove the under panel. Remove the screws of the right and left side drain pan.
- (5) Remove the 2 insulations in centre of the drain pan, and after removing the 2 screws, remove the drain pan.

(Note)

Please be aware that there might be drain left in the drain pan when you remove the drain pump (option).

PHOTOS

Photo 8

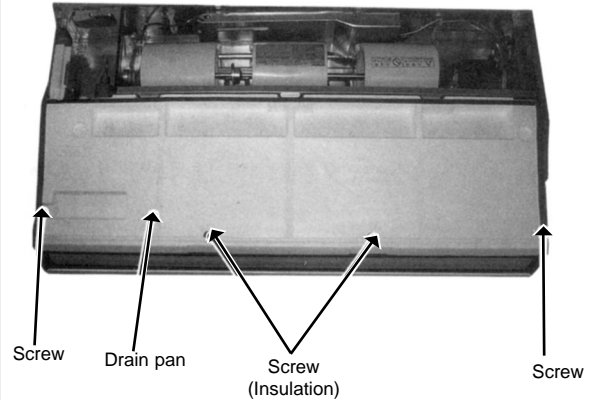

10. Removing the guide vane

- (1) Remove the intake grille. (See the figure 1)
- (2) Remove the beam.
- (3) Remove the side panels (right and left). (See the figure 3)
- (4) Remove the under panel. (See the photo 7)
- (5) Remove the drain pan. (See the photo 8)
- (6) Remove the screw from the guide vane, then remove the guide vane.

Photo 9

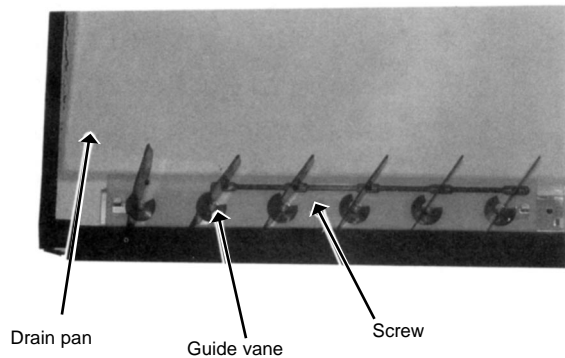

11. Removing the Auto vane

- (1) Remove the intake grille. (See the figure 1)
- (2) Remove the left side panel. (See the figure 3)
- (3) Remove the left side box.
- (4) Remove the under panel.
- (5) Remove the screw from the auto vane.
- (6) Slide the auto vane to the right side and pull the auto vane out.

Photo 10

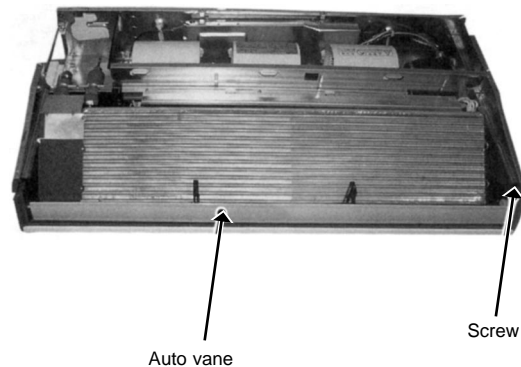

OPERATING PROCEDURE

12. Removing the heat exchanger

- (1) Remove the air intake grille. (See the figure 1)
- (2) Remove the beam.
- (3) Remove the side panel (right and left). (See the figure 3)
- (4) Disconnect the relay connector of the pipe thermistor.
- (5) Remove the under panel. (See the photo 7)
- (6) Remove the drain pan. (See the photo 8)
- (7) Unscrew the screw of the pipe cover, and remove the pipe cover.
- (8) Unscrew the screw of the pipe support, and remove the pipe support.
- (9) Unscrew the screw of the heat exchanger, and remove the heat exchanger.
Remove the heat exchanger with care. Since this is quite heavy, removing work should be done with more than 2 people.
*Weight of heat exchanger : Approx. 5.3kg

PHOTOS

Photo 11

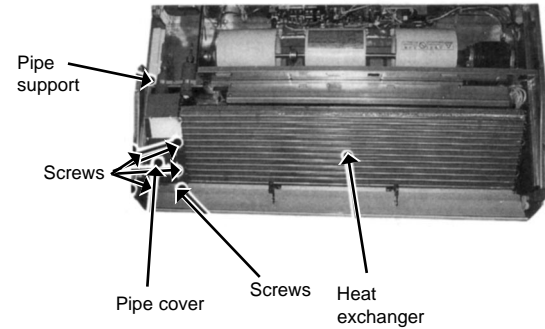

FAN AND FUNCTIONAL PARTS

PCA-A24GA PCA-A30GA

PCA-A36GA PCA-A42GA

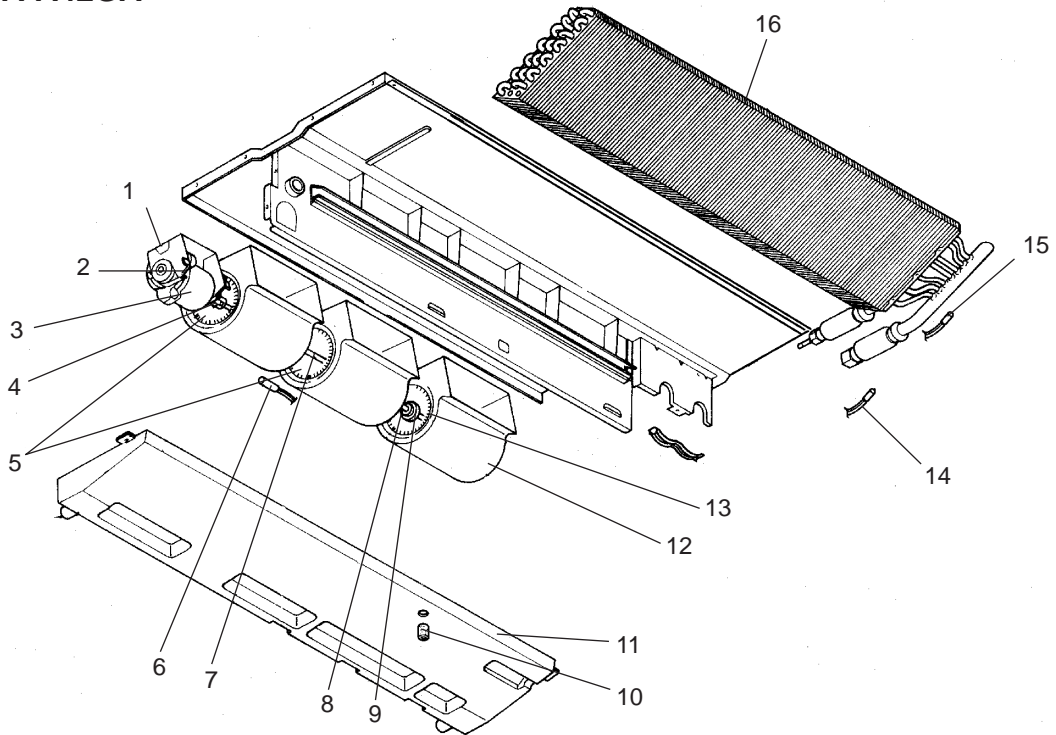

No.	Parts No.	Parts Name	Specifications	Q'ty/set		Remarks (Drawing No.)	Wiring Diagram Symbol	Recomend Q'ty
				PCA-A				
				24/30	36/42			
				GA				
1	R01 29J 130	MOTOR LEG		1				
	R01 35J 130	MOTOR LEG			1			
2	R01 43E 126	PIECE(MOTOR)		1	1			
3	T7W 30J 762	FAN MOTOR	D09C4P70MS	1			MF	
	T7W E14 762	FAN MOTOR	D10C4P90MS		1		MF	
4	R01 700 116	SHAFT JOINT		1	1			
5	R01 E17 114	SIROCCO FAN		2				
	R01 E19 114	SIROCCO FAN			2			
6	R01 E26 202	ROOM TEMPERATURE THERMISTOR		1	1		TH1	
7	R01 29J 100	SHAFT		1	1			
8	R01 E00 103	SLEEVE BEARING		1	1			
9	R01 29J 145	BEARING SUPPORT		1				
	R01 35J 145	BEARING SUPPORT			1			
10	R01 17J 524	DRAIN PLUG		1	1			
11	T7W E20 529	DRAIN PAN ASSY		1				
	T7W E15 529	DRAIN PAN ASSY			1			
12	R01 17J 110	CASING		3				
	R01 35J 110	CASING			3			
13	R01 E15 114	SIROCCO FAN		1				
	R01 E20 114	SIROCCO FAN			1			
14	R01 E27 202	LIQUID PIPE TEMPERATURE THERMISTOR		1	1		TH2	
15	R01 17J 202	COND/EVA TEMPERATURE THERMISTOR		1	1		TH5	
16	T7W H23 480	HEAT EXCHANGER		1				
	T7W H24 480	HEAT EXCHANGER			1			

STRUCTURAL PART

PCA-A24GA
PCA-A30GA
PCA-A36GA
PCA-A42GA

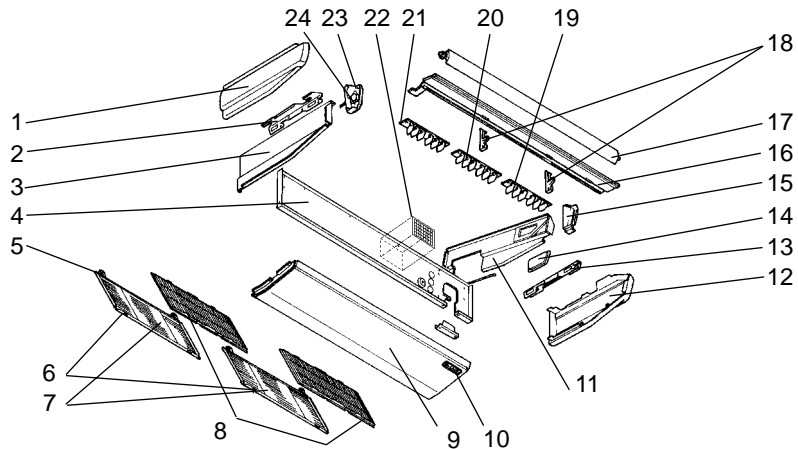

Part numbers that are circled are not shown in the figure.

No.	Parts No.	Parts Name	Specifications	Q'ty/set		Remarks (Drawing No.)	Wiring Diagram Symbol	Recom- mended Q'ty
				PCA-A				
				24/30	36/42			
				GA				
1	R01 17J 662	LEFT SIDE PANEL		1				
	R01 35J 662	LEFT SIDE PANEL			1			
2	R01 17J 809	LEFT LEG		1	1			
3	T7W E01 666	S.PLATE-L		1				
	T7W E00 666	S.PLATE-L			1			
4	T7W E05 676	REAR PANEL		1				
	T7W E00 676	REAR PANEL			1			
5	R01 17J 061	GRILLE HINGE		4	4			
	R01 17J 054	GRILLE CATCH		4	4			
7	R01 17J 691	GRILLE ASSY		2	2			
	R01 A14 500	L.L FILTER		2	2			
9	R01 29J 669	UNDER PANEL		1	1			
	T7W E01 070	W.BOARD CASE		1	1			
11	T7W E01 665	S.PLATE-R		1				
	T7W E00 665	S.PLATE-R			1			
12	R01 17J 661	RIGHT SIDE PANEL		1				
	R01 35J 661	RIGHT SIDE PANEL			1			
13	R01 17J 808	RIGHT LEG		1	1			
14	T7W E05 668	SERVICE PANEL		1				
	T7W E01 668	SERVICE PANEL			1			
15	R01 17J 067	RIGHT SIDE BOX		1				
	R01 35J 067	RIGHT SIDE BOX			1			
16	T7W E05 651	FRONT PANEL		1				
	T7W E00 651	FRONT PANEL			1			
17	R01 29J 002	AUTO VANE		1				
	R01 E03 002	AUTO VANE			1			
18	R01 E00 033	VANE SUPPORT		2				
	R01 E01 033	VANE SUPPORT			2			
19	R01 37J 085	G.V ASSY-6R		1	1			
20	R01 37J 087	G.V ASSY-6C		1	1			
21	R01 37J 086	G.V ASSY-6L		1	1			
22	T7W E01 501	AIR FILTER		1				
	T7W 051 501	AIR FILTER			1			
23	R01 17J 068	LEFT SIDE BOX		1				
	R01 E00 068	LEFT SIDE BOX			1			
24	R01 29J 223	VANE MOTOR		1			MV	
	R01 35J 223	VANE MOTOR			1		MV	
25	R01 17J 523	JOINT SOCKET		1	1			
26	T7W E00 072	DRAIN HOSE COVER		1	1			

ELECTRICAL PARTS

PCA-A24GA

PCA-A30GA

PCA-A36GA

PCA-A42GA

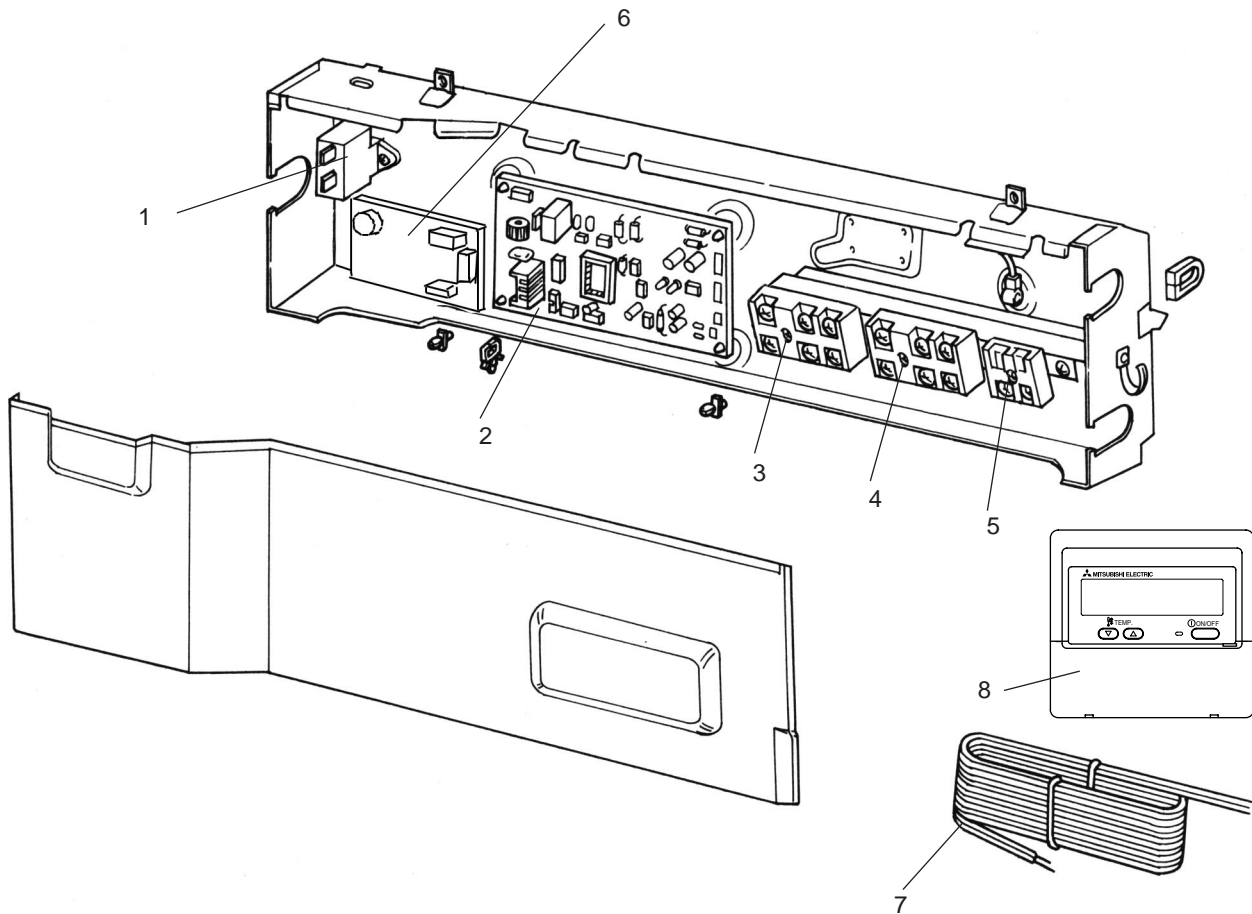

No.	Parts No.	Parts Name	Specifications	Q'ty/ set		Remarks (Drawing No.)	Wiring Diagram Symbol	Recom- mended Q'ty
				PCA-A				
				24/30	36/42			
1	T7W E18 255	CAPACITOR	4 μ F 440V	1			C	
	T7W E19 255	CAPACITOR	5 μ F 440V		1		C	
2	T7W E56 310	INDOOR CONTROLLER BOARD		1	1		I.B	
3	T7W E41 716	TERMINAL BLOCK	3P(L1,L2,GR)	1	1		TB2	
4	R01 E18 246	TERMINAL BLOCK	3P(S1,S2,S3)	1	1		TB4	
5	R01 E21 246	TERMINAL BLOCK	2P(1,2)	1	1		TB5	
6	T7W E35 313	POWER BOARD		1	1		P.B	
7	T7W A01 305	REMOTE CONTROLLER CORD		1	1			
8	T7W E14 713	REMOTE CONTROLLER	PAR-21MAA	1	1		R.B	

FAN AND FUNCTIONAL PARTS

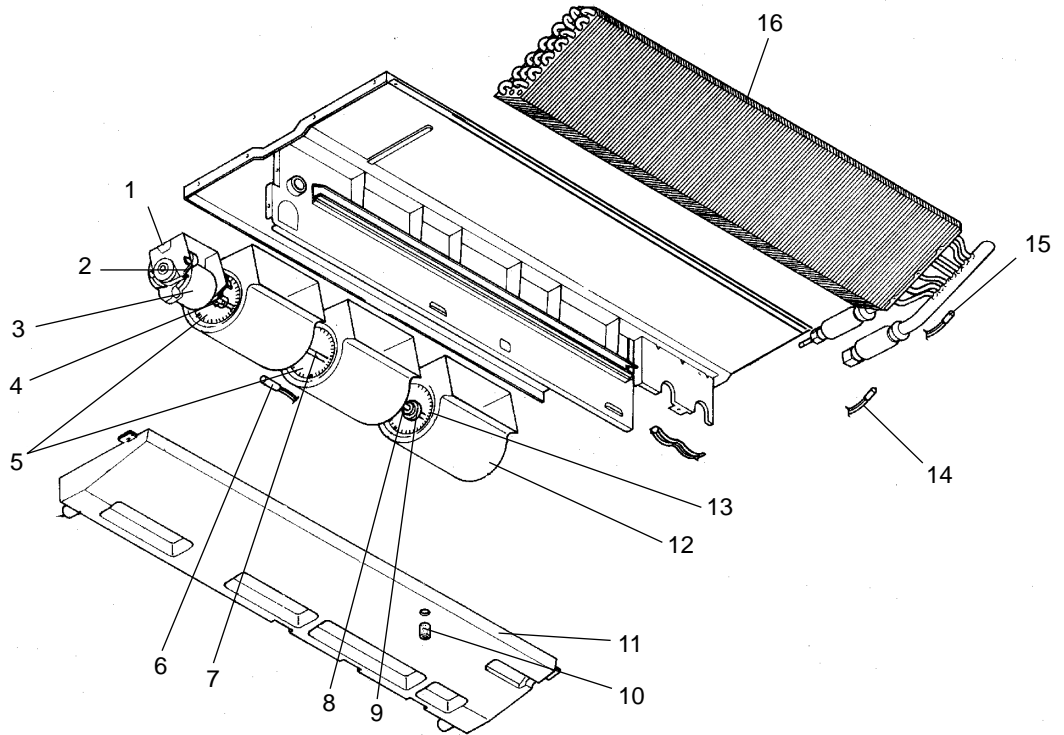
PCA-A24GA₁ PCA-A30GA₁ PCA-A36GA₁ PCA-A42GA₁PCA-A24GA₂ PCA-A30GA₂ PCA-A36GA₂ PCA-A42GA₂

No.	RoHS	Parts No.	Parts Name	Specifications	Q'ty/set		Remarks (Drawing No.)	Wiring Diagram Symbol	Recom- mended Q'ty
					PCA-A 24/30 GA ₁ , GA ₂	36/42			
1	G	R01 30J 130	MOTOR LEG		1				
	G	R01 32J 130	MOTOR LEG			1			
2	G	R01 45E 126	PIECE(MOTOR)		1	1			
3	G	T7W 40J 762	FAN MOTOR	D09C4P70MS	1			MF	
	G	T7W E31 762	FAN MOTOR	D10C4P90MS		1		MF	
4	G	R01 800 116	SHAFT JOINT		1	1			
5	G	R01 E17 114	SIROCCO FAN		2				
	G	R01 E19 114	SIROCCO FAN			2			
6	G	R01 H08 202	ROOM TEMPERATURE THERMISTOR		1	1		TH1	
7	G	R01 30J 100	SHAFT		1	1			
8	G	R01 E02 103	SLEEVE BEARING		1	1			
9	G	R01 30J 145	BEARING SUPPORT		1				
	G	R01 36J 145	BEARING SUPPORT			1			
10	G	R01 18J 524	DRAIN PLUG		1	1			
11	G	T7W E30 529	DRAIN PAN ASSY		1				
	G	T7W E31 529	DRAIN PAN ASSY			1			
12	G	R01 18J 110	CASING		3				
	G	R01 19J 110	CASING			3			
13	G	R01 E15 114	SIROCCO FAN		1				
	G	R01 E20 114	SIROCCO FAN			1			
14	G	R01 H10 202	LIQUID PIPE TEMPERATURE THERMISTOR		1	1		TH2	
15	G	R01 H09 202	CONDEVA TEMPERATURE THERMISTOR		1	1		TH5	
16	G	T7W H23 480	HEAT EXCHANGER		1				
	G	T7W H24 480	HEAT EXCHANGER			1			

STRUCTURAL PART

PCA-A24GA₁
 PCA-A30GA₁
 PCA-A36GA₁
 PCA-A42GA₁
 PCA-A24GA₂
 PCA-A30GA₂
 PCA-A36GA₂
 PCA-A42GA₂

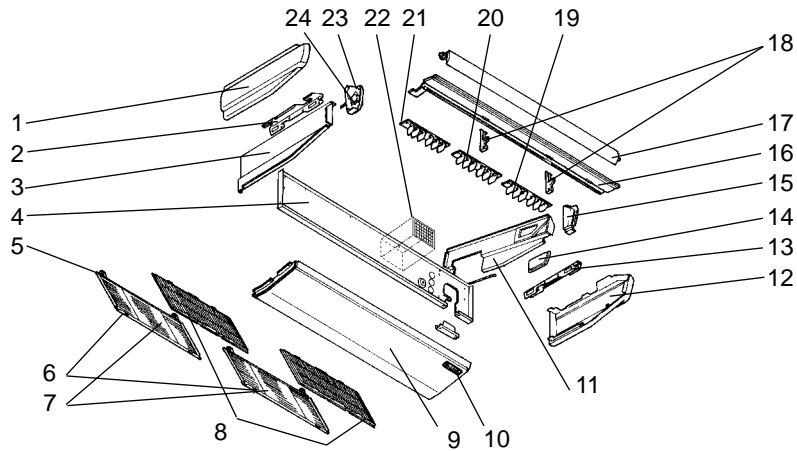

Part numbers that are circled are not shown in the figure.

No.	RoHS	Parts No.	Parts Name	Specifications	Q'ty/set				Remarks (Drawing No.)	Wiring Diagram Symbol	Recom- mended Q'ty
					PCA-A		24/30 GA ₁	36/42 GA ₂			
1	G	R01 18J 662	LEFT SIDE PANEL		1	1					
	G	R01 36J 662	LEFT SIDE PANEL			1	1				
2	G	R01 18J 809	LEFT LEG		1	1	1	1			
3	G	T7W E02 666	S.PLATE-L		1	1					
	G	T7W E03 666	S.PLATE-L			1	1				
4	G	T7W E07 676	REAR PANEL		1	1					
	G	T7W E08 676	REAR PANEL			1	1				
5	G	R01 18J 061	GRILLE HINGE		4	4	4	4			
6	G	R01 19J 054	GRILLE CATCH		4	4	4	4			
7	G	R01 19J 691	GRILLE ASSY		2	2	2	2			
8	G	R01 A29 500	L.L FILTER		2	2	2	2			
9	G	R01 30J 669	UNDER PANEL		1	1	1	1			
10	G	T7W E02 070	W.BOARD CASE		1	1	1	1			
11	G	T7W E03 665	S.PLATE-R		1	1					
	G	T7W E04 665	S.PLATE-R			1	1				
12	G	R01 18J 661	RIGHT SIDE PANEL		1	1					
	G	R01 36J 661	RIGHT SIDE PANEL			1	1				
13	G	R01 18J 808	RIGHT LEG		1	1	1	1			
14	G	T7W E10 668	SERVICE PANEL		1	1					
	G	T7W E11 668	SERVICE PANEL			1	1				
15	G	R01 18J 067	RIGHT SIDE BOX		1	1					
	G	R01 36J 067	RIGHT SIDE BOX			1	1				
16	G	T7W E08 651	FRONT PANEL		1	1					
	G	T7W E09 651	FRONT PANEL			1	1				
17	G	R01 30J 002	AUTO VANE		1	1					
	G	R01 E14 002	AUTO VANE			1	1				
18	G	R01 E02 033	VANE SUPPORT		2	2					
	G	R01 E03 033	VANE SUPPORT			2	2				
19	G	R01 38J 085	G.V ASSY-6R		1	1	1	1			
20	G	R01 38J 087	G.V ASSY-6C		1	1	1	1			
21	G	R01 38J 086	G.V ASSY-6L		1	1	1	1			
22	G	T7W E03 501	AIR FILTER		1	1					
	G	T7W E04 501	AIR FILTER			1	1				
23	G	R01 18J 068	LEFT SIDE BOX		1	1					
	G	R01 E01 068	LEFT SIDE BOX			1	1				
24	G	R01 E10 223	VANE MOTOR		1	1			MV		
	G	R01 E12 223	VANE MOTOR			1	1		MV		
25	G	R01 18J 523	JOINT SOCKET		1	1	1	1			
26	G	T7W E01 072	DRAIN HOSE COVER		1	1					
	G	R01 18J 072	DRAIN HOSE COVER			1	1				

ELECTRICAL PARTS

PCA-A24GA₁ PCA-A30GA₁ PCA-A36GA₁ PCA-A42GA₁
 PCA-A24GA₂ PCA-A30GA₂ PCA-A36GA₂ PCA-A42GA₂

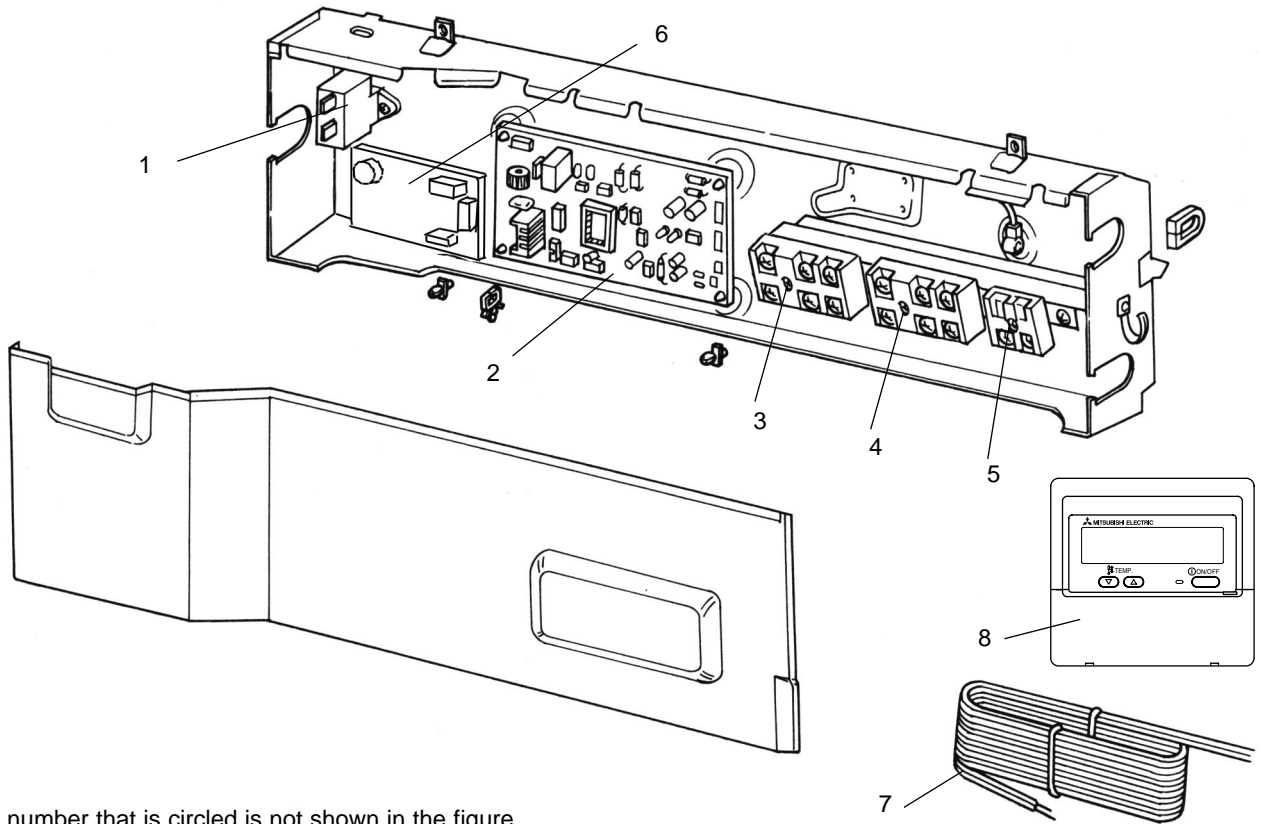

Part number that is circled is not shown in the figure.

No.	ROHS	Parts No.	Parts Name	Specifications	Q'ty/ set				Remarks (Drawing No.)	Wiring Diagram Symbol	Recom- mended Q'ty
					PCA-A						
					24/30 GA ₁	36/42 GA ₁	24/30 GA ₂	36/42 GA ₂			
1	G	T7W E18 255	CAPACITOR	4 μ F 440V	1		1			C	
	G	T7W E19 255	CAPACITOR	5 μ F 440V		1		1		C	
2	G	T7W E56 310	INDOOR CONTROLLER BOARD		1	1				I.B	
	G	T7W E70 310	INDOOR CONTROLLER BOARD				1	1		I.B	
3	G	T7W E41 716	TERMINAL BLOCK	3P(L1,L2,GR)	1	1				TB2	
4	G	R01 E18 246	TERMINAL BLOCK	3P(S1,S2,S3)	1	1	1	1		TB4	
5	G	R01 E21 246	TERMINAL BLOCK	2P(1,2)	1	1				TB5	
	G	T7W E46 716	TERMINAL BLOCK	2P(1,2)			1	1		TB5	
6	G	T7W E35 313	POWER BOARD		1	1	1	1		P.B	
7	G	T7W A01 305	REMOTE CONTROLLER CORD	10m 33ft	1	1	1	1			
8	G	T7W E14 713	REMOTE CONTROLLER	PAR-21MAA	1	1	1	1		R.B	
⑨	G	R01 E06 239	FUSE	6.3A 250V	1	1	1	1		FUSE	

Mr. SLIM™



HEAD OFFICE : TOKYO BLDG., 2-7-3, MARUNOUCHI, CHIYODA-KU, TOKYO 100-8310, JAPAN

©Copyright 2006 MITSUBISHI ELECTRIC ENGINEERING CO., LTD.
Distributed in Oct. 2007 No.OC368 REVISED EDITION-C PDF 9
Distributed in Jun. 2007 No.OC368 REVISED EDITION-B PDF 9
Distributed in Aug. 2006 No.OC368 REVISED EDITION-A PDF 9
Distributed in Feb. 2006 No.OC368 PDF 10
Made in Japan

New publication, effective Oct. 2007
Specifications subject to change without notice.