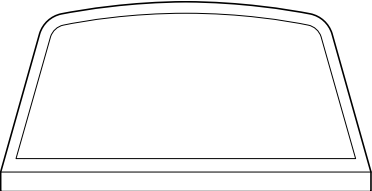
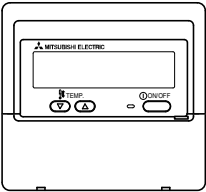
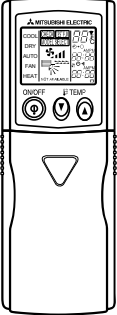
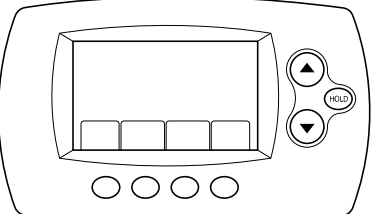

1-1. OUTDOOR UNIT SERVICE MANUAL

| Service Ref. | Service Manual No. |
|--|--------------------|
| PUZ-A18/24/36NHA4 PUZ-A18/24/36NHA4-BS PUY-A12/18/24/36NHA4 PUY-A12/18/24/36NHA4-BS | OCH481 OCB481 |

■ Remote controller (Optional parts)

| Radio frequency interface | Wired remote controller | IR wireless remote controller |
|---|---|--|
|  |  |  |
| RF thermostat | | |
|  | | |

2

SAFETY PRECAUTION

2-1. ALWAYS OBSERVE FOR SAFETY

Before obtaining access to terminal, all supply circuits must be disconnected.

2-2. CAUTIONS RELATED TO NEW REFRIGERANT

Cautions for units utilising refrigerant R410A

Use new refrigerant pipes.

Make sure that the inside and outside of refrigerant piping is clean and it has no contaminants such as sulfur, oxides, dirt, shaving particles, etc, which are hazards to refrigerant cycle. In addition, use pipes with specified thickness.

Contamination inside refrigerant piping can cause deterioration of refrigerant oil etc.

Store the piping to be used indoors during installation, and keep both ends of the piping sealed until just before brazing. (Leave elbow joints, etc. in their packaging.)

If dirt, dust or moisture enters into refrigerant cycle, that can cause deterioration of refrigerant oil or malfunction of compressor.

The refrigerant oil applied to flare and flange connections must be ester oil, ether oil or alkylbenzene oil in a small amount.

If large amount of mineral oil enters, that can cause deterioration of refrigerant oil etc.

Charge refrigerant from liquid phase of gas cylinder.

If the refrigerant is charged from gas phase, composition change may occur in refrigerant and the efficiency will be lowered.

Do not use refrigerant other than R410A.

If other refrigerant (R22 etc.) is used, chlorine in refrigerant can cause deterioration of refrigerant oil etc.

Use a vacuum pump with a reverse flow check valve.

Vacuum pump oil may flow back into refrigerant cycle and that can cause deterioration of refrigerant oil etc.

Use the following tools specifically designed for use with R410A refrigerant.

The following tools are necessary to use R410A refrigerant.

| Tools for R410A | |
|-------------------|---------------------------------------|
| Gauge manifold | Flare tool |
| Charge hose | Size adjustment gauge |
| Gas leak detector | Vacuum pump adaptor |
| Torque wrench | Electronic refrigerant charging scale |

Handle tools with care.

If dirt, dust or moisture enters into refrigerant cycle, that can cause deterioration of refrigerant oil or malfunction of compressor.

Do not use a charging cylinder.

If a charging cylinder is used, the composition of refrigerant will change and the efficiency will be lowered.

Ventilate the room if refrigerant leaks during operation. If refrigerant comes into contact with a flame, poisonous gases will be released.

[1] Cautions for service

- (1) Perform service after recovering the refrigerant left in unit completely.
- (2) Do not release refrigerant in the air.
- (3) After completing service, charge the cycle with specified amount of refrigerant.
- (4) When performing service, install a filter drier simultaneously.
Be sure to use a filter drier for new refrigerant.

[2] Additional refrigerant charge

When charging directly from cylinder

- Check that cylinder for R410A on the market is syphon type.
- Charging should be performed with the cylinder of syphon stood vertically. (Refrigerant is charged from liquid phase.)

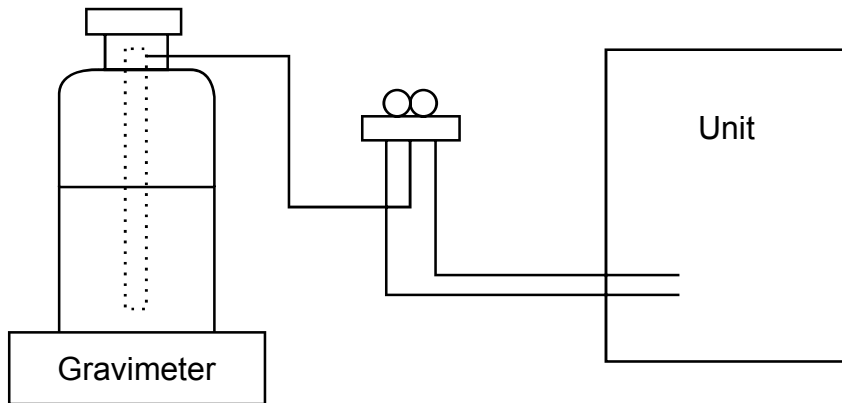

[3] Service tools

Use the below service tools as exclusive tools for R410A refrigerant.

| No. | Tool name | Specifications |
|-----|--------------------------------|--|
| ① | Gauge manifold | <ul style="list-style-type: none"> · Only for R410A · Use the existing fitting specifications. (UNF1/2) · Use high-tension side pressure of 5.3MPa·G or over. |
| ② | Charge hose | <ul style="list-style-type: none"> · Only for R410A · Use pressure performance of 5.09MPa·G or over. |
| ③ | Electronic scale | — |
| ④ | Gas leak detector | · Use the detector for R134a, R407C or R410A. |
| ⑤ | Adaptor for reverse flow check | · Attach on vacuum pump. |
| ⑥ | Refrigerant charge base | — |
| ⑦ | Refrigerant cylinder | <ul style="list-style-type: none"> · Only for R410A · Top of cylinder (Pink) · Cylinder with syphon |
| ⑧ | Refrigerant recovery equipment | — |

3 PART NAMES AND FUNCTIONS

• Indoor unit

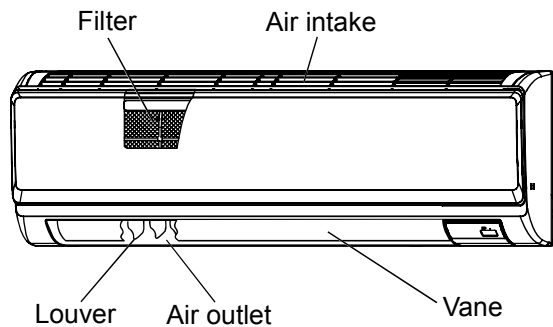

• Wired remote controller (Option)

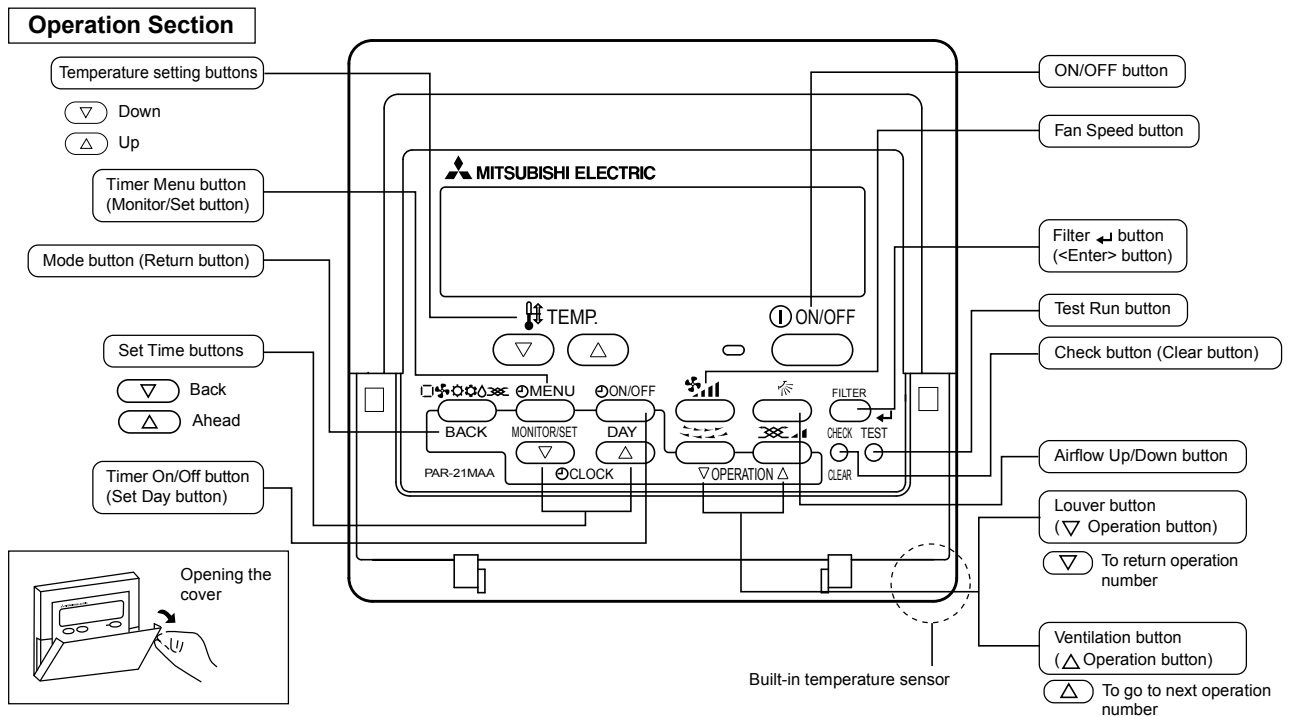
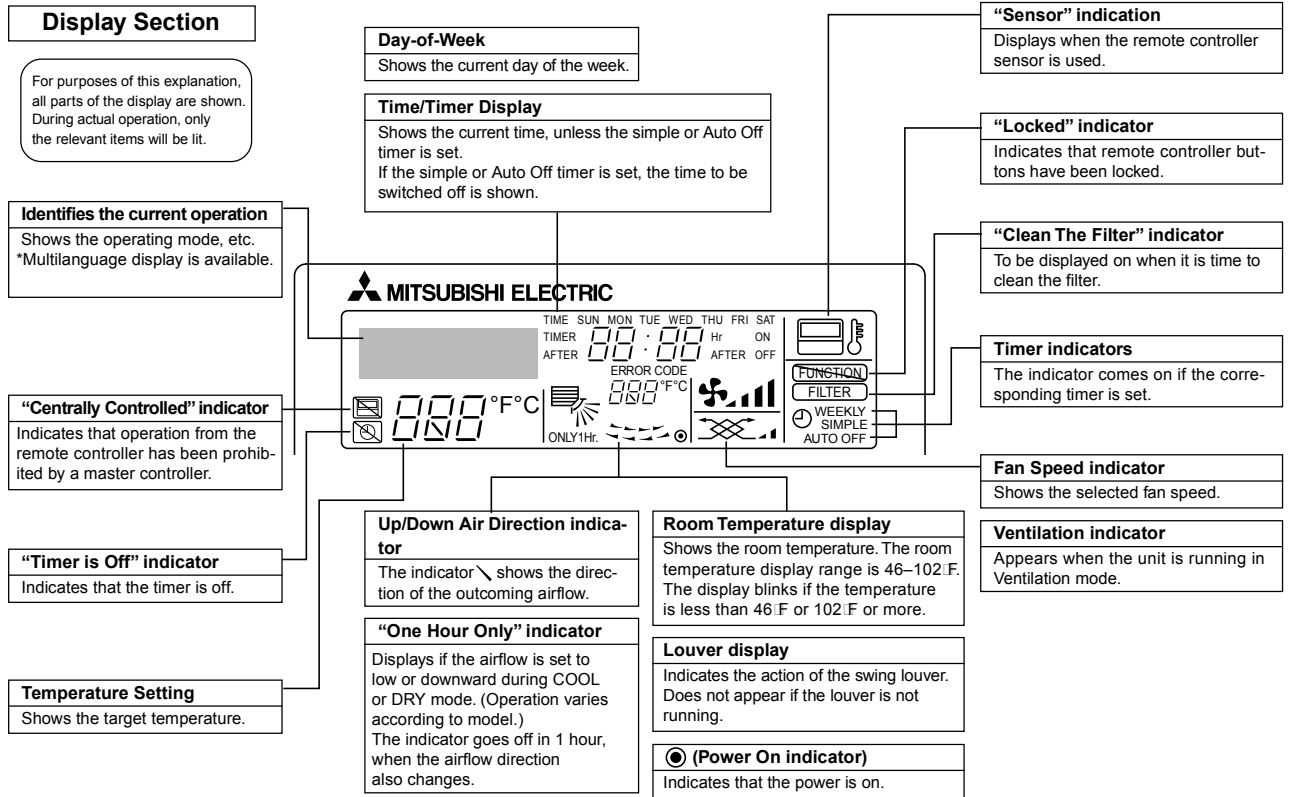

Note:

- “PLEASE WAIT” message
This message is displayed for approximately 3 minutes when power is supplied to the indoor unit or when the unit is recovering from a power failure.
- “NOT AVAILABLE” message
This message is displayed if an invalid button is pressed (to operate a function that the indoor unit does not have).
If a single remote controller is used to operate multiple indoor units simultaneously that are different types, this message will not be displayed as far as any of the indoor units is equipped with the function.

● IR wireless remote controller (Option)

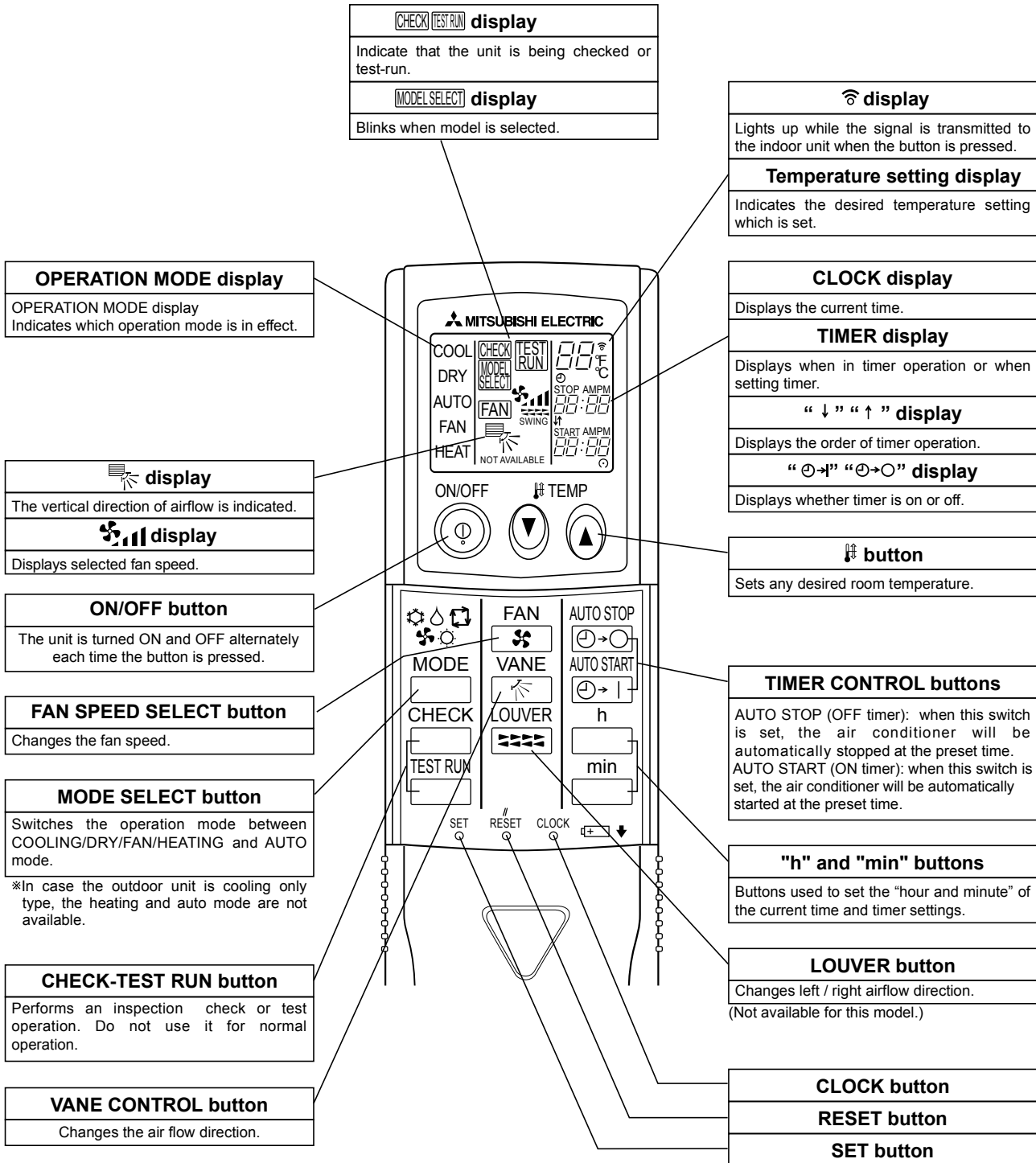

4

SPECIFICATIONS

| Service Ref. | | | PKA-A12HA4 | |
|--------------|-------------------------------------|--------------------------|------------------------------|---|
| INDOOR UNIT | Power supply(phase, cycle, voltage) | | 1 phase, 60Hz, 208/230V | |
| | Max. Fuse Size | A | 15 | |
| | Min.Circuit Ampacity | A | 1 | |
| | External finish | | White Munsell 1.0Y 9.2/0.2 | |
| | Heat exchanger | | Plate fin coil | |
| | Fan | Fan(drive) × No. | | Line flow fan (direct) × 1 |
| | | Fan motor output | kW | 0.030 |
| | | Fan motor | F.L.A | 0.33 |
| | | Airflow(Low-Middle-High) | m³/min(CFM) | Dry: 9-10.5-12 (320-370-425) Wet: 8-9.5-11 (290-335-380) |
| | | External static pressure | Pa(mmAq) | 0(direct blow) |
| | Operation control & Thermostat | | Remote controller & built-in | |
| | Noise level(Low-Middle-High) | | 36-40-43 | |
| | Field drain pipe O.D. | | 16(5/8) | |
| | Dimensions | W | mm(in.) | 898 (35-3/8) |
| | | D | mm(in.) | 249 (9-13/16) |
| H | | mm(in.) | 295 (11-5/8) | |
| Weight | | kg(lbs) | 13 (29) | |

| Service Ref. | | | PKA-A18HA4 | |
|--------------|-------------------------------------|--------------------------|------------------------------|---|
| INDOOR UNIT | Power supply(phase, cycle, voltage) | | 1 phase, 60Hz, 208/230V | |
| | Max. Fuse Size | A | 15 | |
| | Min.Circuit Ampacity | A | 1 | |
| | External finish | | White Munsell 1.0Y 9.2/0.2 | |
| | Heat exchanger | | Plate fin coil | |
| | Fan | Fan(drive) × No. | | Line flow fan (direct) × 1 |
| | | Fan motor output | kW | 0.030 |
| | | Fan motor | F.L.A | 0.33 |
| | | Airflow(Low-Middle-High) | m³/min(CFM) | Dry: 9-10.5-12 (320-370-425) Wet: 8-9.5-11 (290-335-380) |
| | | External static pressure | Pa(mmAq) | 0(direct blow) |
| | Operation control & Thermostat | | Remote controller & built-in | |
| | Noise level(Low-Middle-High) | | 36-40-43 | |
| | Field drain pipe O.D. | | 16(5/8) | |
| | Dimensions | W | mm(in.) | 898 (35-3/8) |
| | | D | mm(in.) | 249 (9-13/16) |
| H | | mm(in.) | 295 (11-5/8) | |
| Weight | | kg(lbs) | 13 (29) | |

5 NOISE CRITERION CURVES

PKA-A12HA4
PKA-A18HA4

| NOTCH | SPL(dB) | LINE |
|-------|---------|------|
| High | 43 | ○—○ |
| Low | 36 | ●—● |

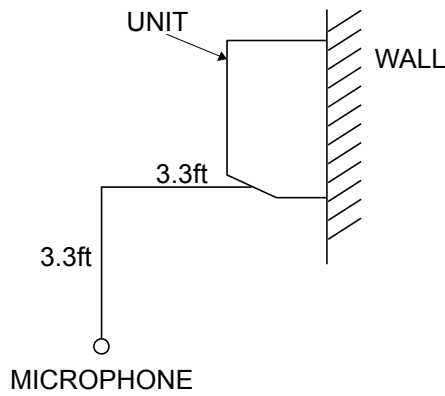
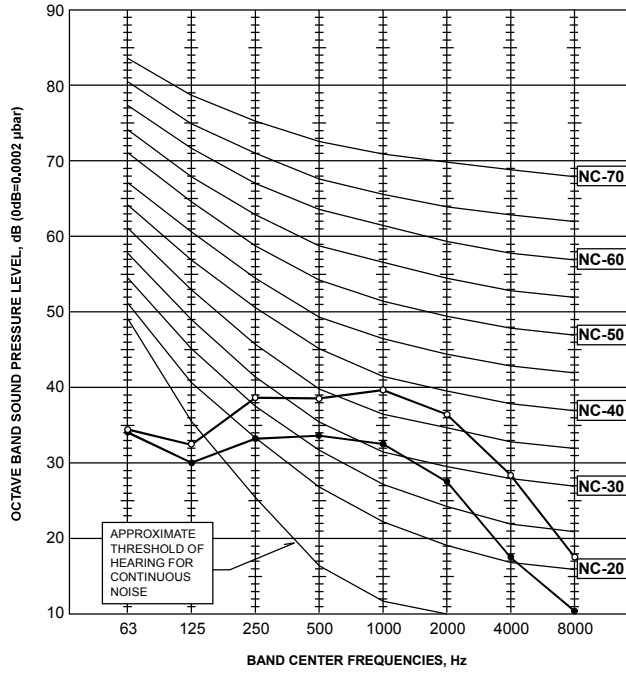

PKA-A12HA4 PKA-A18HA4

Unit: inch (mm)

