

SERVICE PARTS LIST FOR MITSUBISHI ELECTRIC REFRIGERATION SYSTEMS:HOT WATER HEAT PUMP UNIT

Series : CAHV-P·YB-HPB(-BS)

Feb. 2015
BWE015030

INDEX
CAHV-P500YB-HPB
CAHV-P500YB-HPB-BS

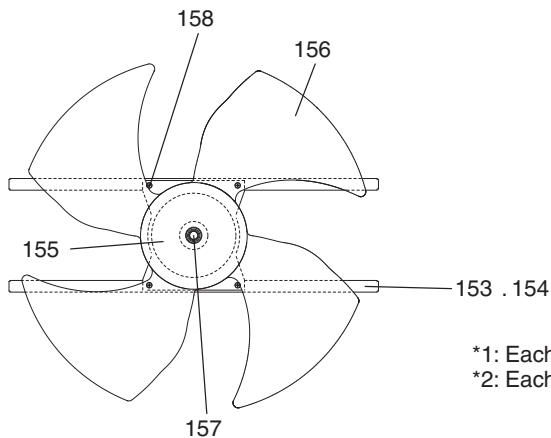
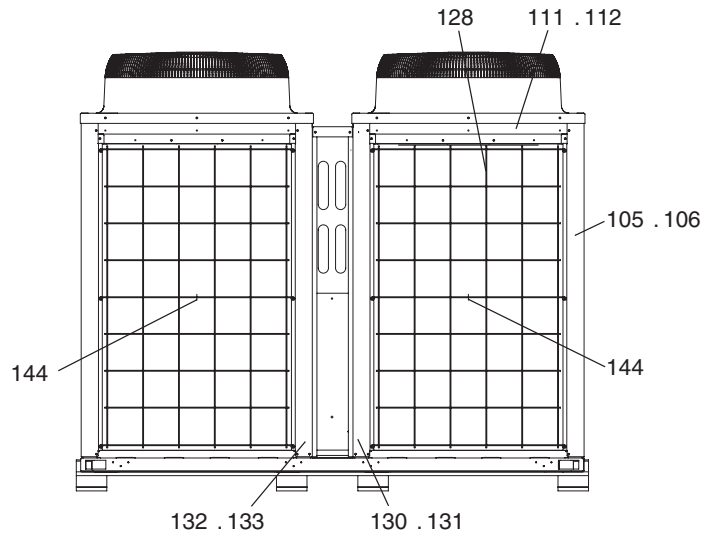
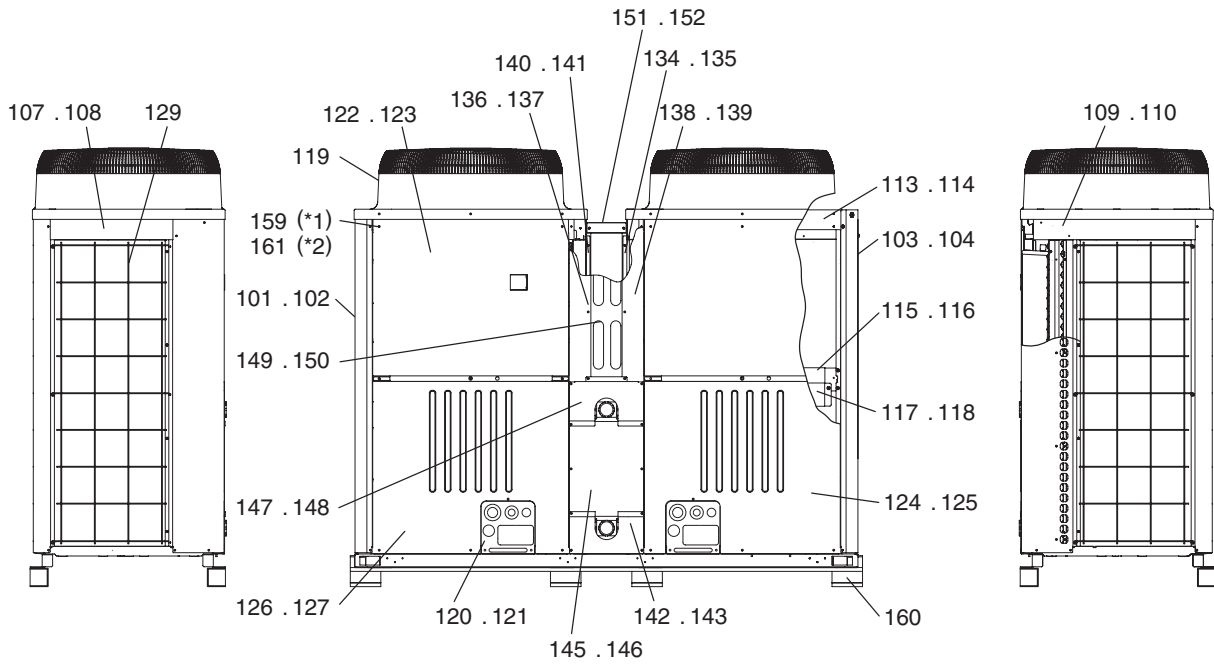

*1: Each unit requires 126 H screws (Part No. 159).

*2: Each unit requires 36 WFT screws (Part No. 161).

No.	Part No.	G : RoHS Apply Only W : RoHS Apply by Running Change		Spec.	CAHV-P500YB-HPB	CAHV-P500YB-HPB-BS				Dwg. No.	Notes for the models	Revision info.
			Part Name									
101	R11 019 626	G	Pillar LF		1					KB02A011G07		
102	R11 020 626	G	Pillar LF	BS		1				KB02A011G08		
103	R11 014 626	G	Pillar RF		1					KB02A012G07		
104	R11 015 626	G	Pillar RF	BS		1				KB02A012G08		
105	R63 002 627	G	Pillar B		2					KB02A013G07		
106	R63 003 627	G	Pillar B	BS		2				KB02A013G08		
107	R63 038 162	G	Frame assy L		2					KD00G100G01		
108	R63 040 162	G	Frame assy L	BS		2				KD00G100G02		
109	R63 039 162	G	Frame assy R		2					KD00G101G01		
110	R63 041 162	G	Frame assy R	BS		2				KD00G101G02		
111	R63 001 216	G	Frame assy B		2					KB00C162G10		
112	R63 002 216	G	Frame assy B	BS		2				KB00C162G11		
113	R63 004 668	G	Frame F		2					KB02J208H01		
114	R12 036 215	G	Frame FB	BS		2				KB02J208G03		
115	R63 013 111	G	Frame assy MU		2					KB00C887G01		
116	R63 014 162	G	Frame assy MU	BS		2				KB00C887G07		
117	R12 024 215	G	Frame assy MB		2					KC00G639G01		
118	R12 026 215	G	Frame assy MB	BS		2				KC00G639G03		
119	R63 4H6 118	G	Fan guard		2	2				KB25A008H07		
120	R61 095 690	G	Cover piping	R2	2					KB02L001G07		
121	R61 094 690	G	Cover piping	R2 BS		2				KB02L001G08		
122	R12 007 669	G	Panel assy FU		2					KN00G568G07		
123	R12 040 661	G	Panel assy FU	BS		2				KN00G568G08		
124	R61 003 652	G	Panel assy FB		1					KB02B392H04		
125	R61 004 652	G	Panel assy FB	BS		1				KB02B392G06		
126	R61 157 651	G	Panel assy FBL		1					KB02J308H02		
127	R61 162 651	G	Panel assy FBL	BS		1				KB02J308G03		
128	R63 004 611	G	Fin guard B		2	2				KB07T208G01		
129	R61 007 611	G	Fin guard LR		2	2				KB07C043G03		
130	R12 001 626	G	Pillar B(R)		1					KC02B363G05		
131	R12 013 626	G	Pillar B(R)	BS		1				KC02B363G06		
132	R12 002 626	G	Pillar B(L)		1					KC02B363G07		
133	R12 012 626	G	Pillar B(L)	BS		1				KC02B363G08		
134	R12 003 626	G	Pillar RF		1					KC02B338G09		
135	R12 007 626	G	Pillar RF	BS		1				KC02B338G10		
136	R12 004 626	G	Pillar F(L)		1					KC02B337G13		
137	R12 008 626	G	Pillar F(L)	BS		1				KC02B337G14		
138	R12 005 626	G	Pillar F(R)		1					KC02B337G15		
139	R12 009 626	G	Pillar F(R)	BS		1				KC02B337G16		
140	R12 014 626	G	Pillar assy LF		1					KC00H676G01		
141	R12 015 626	G	Pillar assy LF	BS		1				KC00H676G02		
142	R12 075 661	G	Panel B		1					KC02L798G01		
143	R12 076 661	G	Panel B	BS		1				KC02L798G02		
144	R63 L59 060	G	Guard fixed plate		2	2				W893727H03		
145	R12 009 669	G	Panel M		1					KC02G150G05		

No.	Part No.	G : RoHS Apply Only W : RoHS Apply by Running Change		Spec.	CAHV-P500YB-HPB CAHV-P500YB-HPB-BS				Dwg. No.	Notes for the models	Revision info.
		Part Name									
146	R12 041 661	G	Panel M	BS	1				KC02G150G06		
147	R12 077 661	G	Panel 1		1				KC02L797G01		
148	R12 078 661	G	Panel 1	BS	1				KC02L797G02		
149	R12 011 669	G	Panel assy F		1				KC00F730G03		
150	R12 043 661	G	Panel assy F	BS	1				KC00F730G04		
151	R12 012 669	G	Panel TOP		1				KC02G028G05		
152	R12 001 641	G	Panel TOP	BS	1				KC02G028G06		
153	R63 4H6 140	G	Base fan		4				KB02D050H01		
154	R63 4H7 140	G	Base fan	BS	4				KB02D050G05		
155	R61 122 220	G	Motor	YC920IA	2	2			P780109X03		
156	R63 4H6 300	G	Fan		2	2			KB25A009H04		
157	R63 4H6 122	G	Box nut	M12 CH	2	2			P552000X01		
158	R63 014 087	G	Upset screw	M6×10	8	8			P516047X01		
159	R63 007 087	G	H screw	5×10 KNURLED (30 pcs)	5	5			KB00H418G14	*1	
160	R61 016 130	G	Attachment leg		8	8			KD02T773G01		
161	R63 006 087	G	WFT screw	5×12 (30 pcs)	2	2			KB00H418G01	*2	

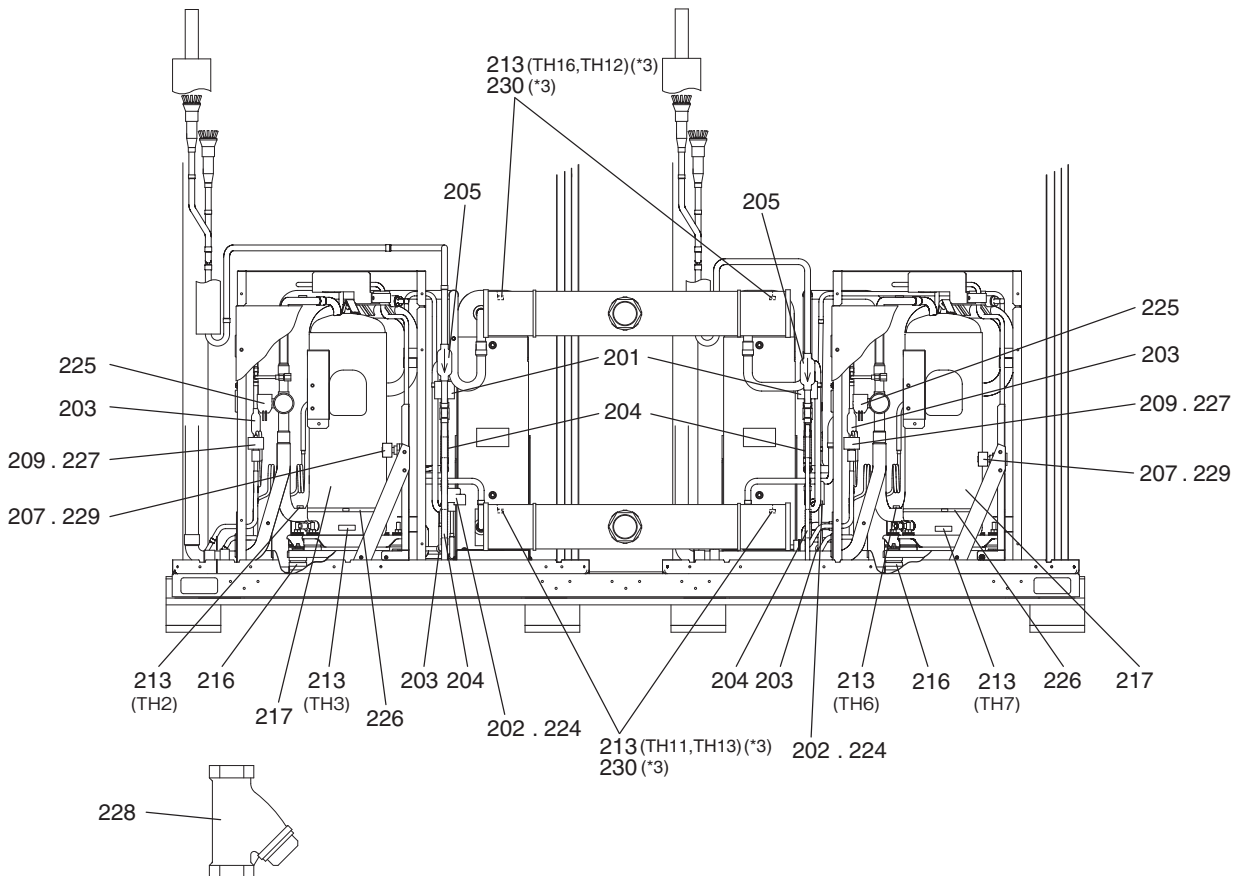
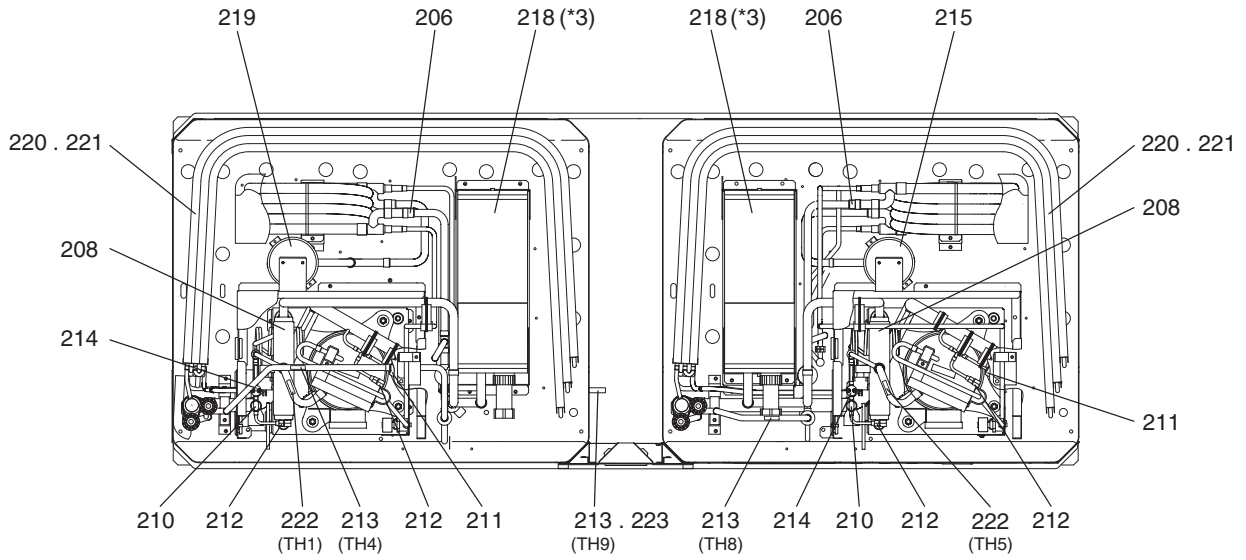

*3: When part 213 (TH11 through TH13, and TH16) or part 218 is replaced, replace part 230 as well.

CAHV-P500YB-HPB
CAHV-P500YB-HPB-BS

FUNCTIONAL PARTS

No.	Part No.	G : RoHS Apply Only W : RoHS Apply by Running Change	Part Name	Spec.	CAHV-P500YB-HPB	CAHV-P500YB-HPB-BS				Dwg. No.	Notes for the models	Revision info.
201	R12 007 920	G	Linear expansion valve	EDM-A0YGMD-10	2	2				KC78H427G05		
202	R63 S84 401	G	Expansion valve	CAM-B50	2	2				P632418X01		
203	R63 0H4 454	G	Strainer	UL R410A	4	4				W882823G02		
204	R63 984 904	G	Check valve	BCV-804DY	4	4				P639163X01		
205	R63 960 907	G	Strainer		2	2				W882826G01		
206	R63 Y03 454	G	Strainer		2	2				W893281G01		
207	R11 007 921	G	Solenoid valve	SEV-502DYFQ69	2	2				P631301X01		
208	R63 Y05 154	G	Four way valve	STF-07	2	2				P633119X01		
209	R63 001 921	G	Solenoid valve	VPV	2	2				P631295X01		
210	R12 006 936	G	Pressure sensor	HP D272	2	2				P418100X01		
211	R12 007 936	G	Pressure sensor	LP D272	2	2				P418099X01		
212	R12 005 904	G	Check joint		4	4				P666009X01		
213	R63 670 202	G	Thermistor	MDW103H	11	11				P425496X01	<3 <TH2~4,TH6~9,TH11~13,TH16>	
214	R12 004 965	G	Pressure switch assy		2	2				KC78F672G02		
215	R12 003 477	G	Receiver assy	(BS)	1	1				KC00B385G09		
216	R63 G95 104	G	Rubber mount		16	16				W836228H01		
217	R69 082 478	G	Compressor		2	2				EP10124B02		
218	R12 007 103	G	Water side HEX. assy		2	2				KC00G087G05	*3	
219	R12 004 477	G	Receiver assy	(BS)	1	1				KC00B385G11		
220	R12 019 105	G	Heat exchanger	3LS (EU)	2					KC01G160G13		
221	R12 017 105	G	Heat exchanger	3L BS		2				KC01G160G12		
222	R63 911 202	G	Thermistor		2	2				P425416X02	<TH1,TH5>	
223	R61 001 310	G	Sensor holder		1	1				KB25B471H03		
224	R63 011 401	G	Solenoid coil	CAM L1800 WHITE	2	2				P472059X02		
225	R63 Y16 243	G	Solenoid coil	STF DV	2	2				P472024X01		
226	R63 Y07 237	G	Belt heater		2	2				P493781X02		
227	R61 006 243	G	Solenoid coil	VPV Y	2	2				P472046X01		
228	R12 007 907	G	Strainer	1-1/2B	1	1				P641138X01		
229	R63 Y13 243	G	Solenoid coil	SEV 240V50	2	2				P472015X01		
230	R12 002 014	G	Insulator		4	4				KC33F724H01	*3	

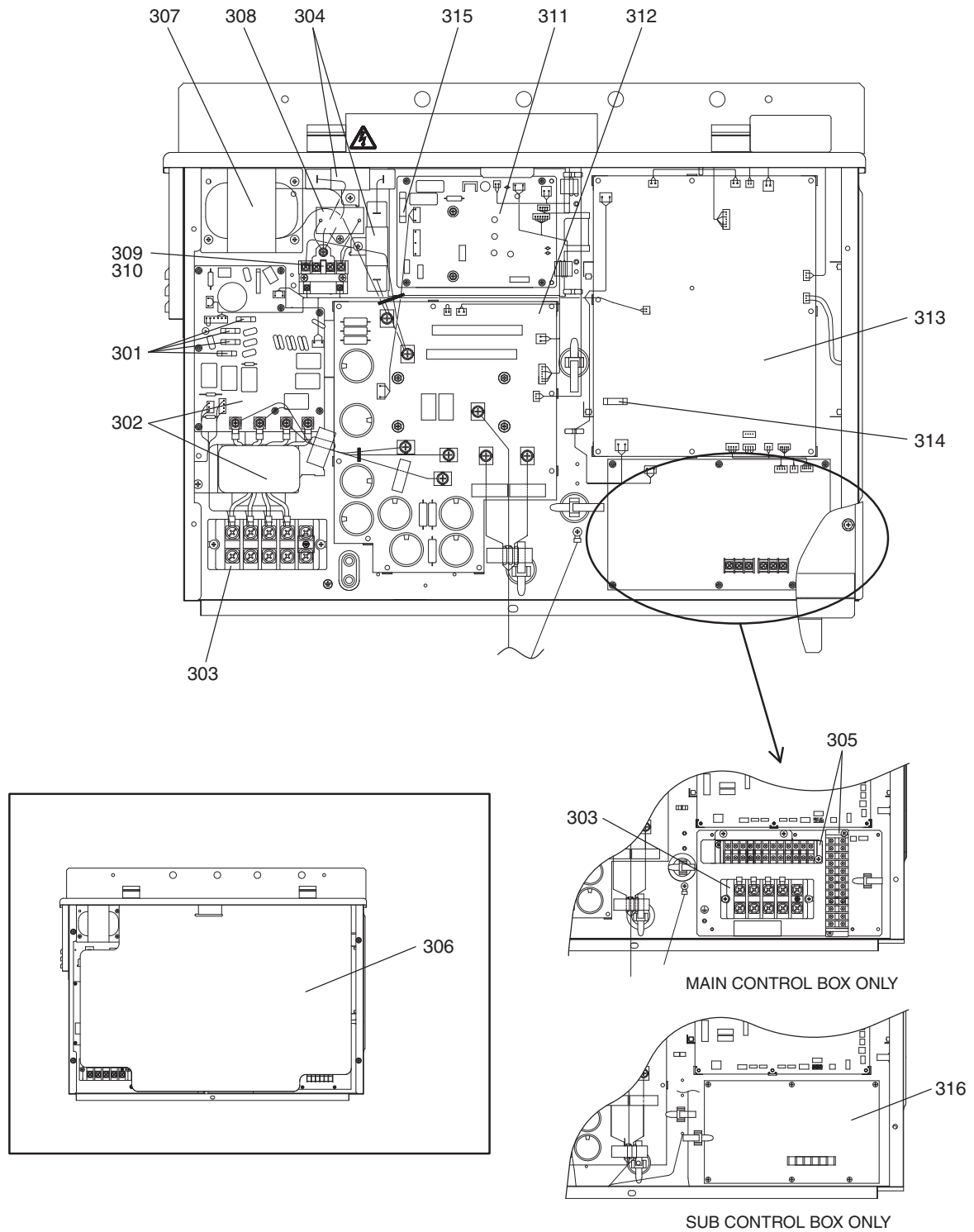

CAHV-P500YB-HPB
CAHV-P500YB-HPB-BS

CONTROL BOX PARTS

No.	Part No.	G : RoHS Apply Only W : RoHS Apply by Running Change		Spec.	CAHV-P500YB-HPB	CAHV-P500YB-HPB-BS					Dwg. No.	Notes for the models	Revision info.
		Part Name											
301	R63 993 964	G	Fuse	6.3A AC250V T	4	4					KG00S514G01		
302	R61 015 293	G	Noise filter	30PYTST4C7-1	2	2					KE80C155G05		
303	R61 007 246	G	Terminal block	HP-T3011A105PL2S	3	3					S436005H12		
304	R61 001 234	G	Resistor	MFS40A220KI	4	4					P411151X01		
305	R63 365 782	G	Terminal block	12P	2	2					P436134X01		
306	R12 017 310	G	Sheet		2	2					KE73C397G02		
307	R61 012 259	G	Reactor	38A 1.92MH	2	2					P715441X02		
308	R61 001 255	G	Capacitor assy		2	2					KE00D263G01		
309	R61 003 216	G	Relay	AHE2231-K1	2	2					P421295X01		
310	R61 018 246	G	Short terminal relay		2	2					KE03D215H02		
311	R61 037 280	G	PCA board assy	INVS06Y	2	2					W652171G07		
312	R12 027 937	G	PCA board assy	INV20Y	2	2					KE80C154G18		
313	R12 029 937	G	PCA board assy	CH10	2	2					KE80C940G02		
314	R61 005 239	G	Fuse	HT 3.15A N5	2	2					S423001H39		
315	R61 016 239	G	Fuse	SHV14 10A	2	2					S423001H36		
316	R61 012 281	G	M-NET board		1	1					KE80C055G03		

mitsubishi
electric
corporation

BWE015030 (20150228)