



SPLIT-TYPE AIR CONDITIONERS

INDOOR UNIT

Revision A:
• MSZ-JP09WA-[U2] and MSZ-JP12WA-[U2]
have been added.

OBH820 is void.

No. OBB820
REVISED EDITION-A

PARTS CATALOG

Models

MSZ-JP09WA - [U1], [U2]

MSZ-JP12WA - [U1], [U2]

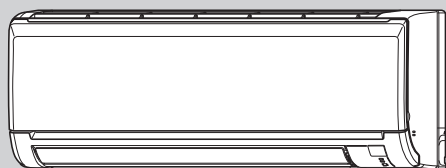

MSZ-JP09WA



CONTENTS

- 1. SERVICE PARTS LIST 2
- 2. OPTIONAL PARTS 8

SERVICE MANUAL (OBH820)

Revision A:

• MSZ-JP09WA-U2 and MSZ-JP12WA-U2 have been added.

1 SERVICE PARTS LIST

MSZ-JP09WA MSZ-JP12WA

1-1. INDOOR UNIT STRUCTURAL PARTS

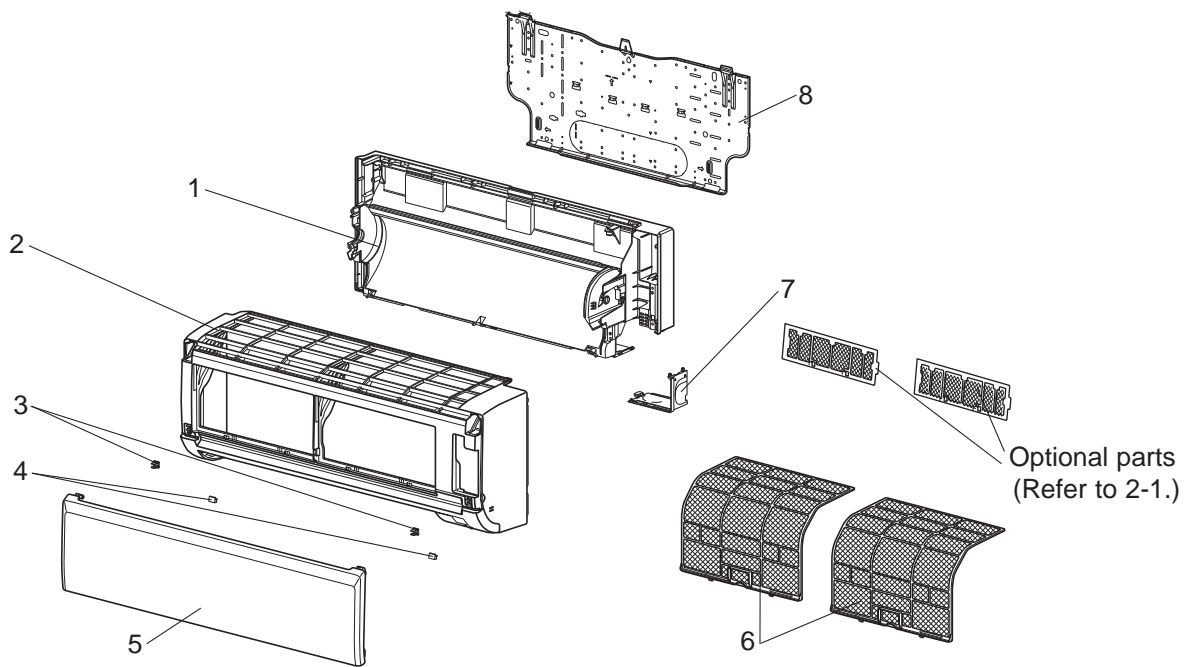

1-2. ACCESSORY AND REMOTE CONTROLLER

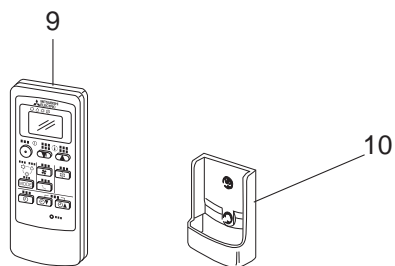

1-1. INDOOR UNIT STRUCTURAL PARTS

1. The part quantity below indicates the required number of pieces per unit.

No.	Part No.	Part name	MSZ-JP09WA-U1	MSZ-JP12WA-U1	MSZ-JP09WA-U2	MSZ-JP12WA-U2	Symbol in Wiring Diagram	Remarks
1	U01 A01 234	BOX ASSEMBLY	1	1	1	1		
2	U01 A03 000	PANEL ASSEMBLY	1	1	1	1		Includes No. 3, 5
3	U01 A01 142	CATCH	2	2	2	2		2 PCS/SET
4	U01 A01 067	SCREW CAP	2	2	2	2		2 PCS/SET
5	U01 A03 010	FRONT PANEL	1	1	1	1		
6	U01 A02 100	ANTI MOLD FILTER	2	2	2	2		1 PC/SET
7	U01 A01 975	CORNER BOX RIGHT	1	1	1	1		
8	U01 A01 970	INSTALLATION PLATE	1	1	1	1		

1-2. ACCESSORY AND REMOTE CONTROLLER

1. The part quantity below indicates the required number of pieces per unit.

No.	Part No.	Part name	MSZ-JP09WA-U1	MSZ-JP12WA-U1	MSZ-JP09WA-U2	MSZ-JP12WA-U2	Symbol in Wiring Diagram	Remarks
9	U01 A05 426	REMOTE CONTROLLER	1	1	1	1		MS16A
10	U01 A01 083	REMOTE CONTROLLER HOLDER	1	1	1	1		

MSZ-JP09WA MSZ-JP12WA

1-3. INDOOR UNIT ELECTRICAL PARTS AND FUNCTIONAL PARTS

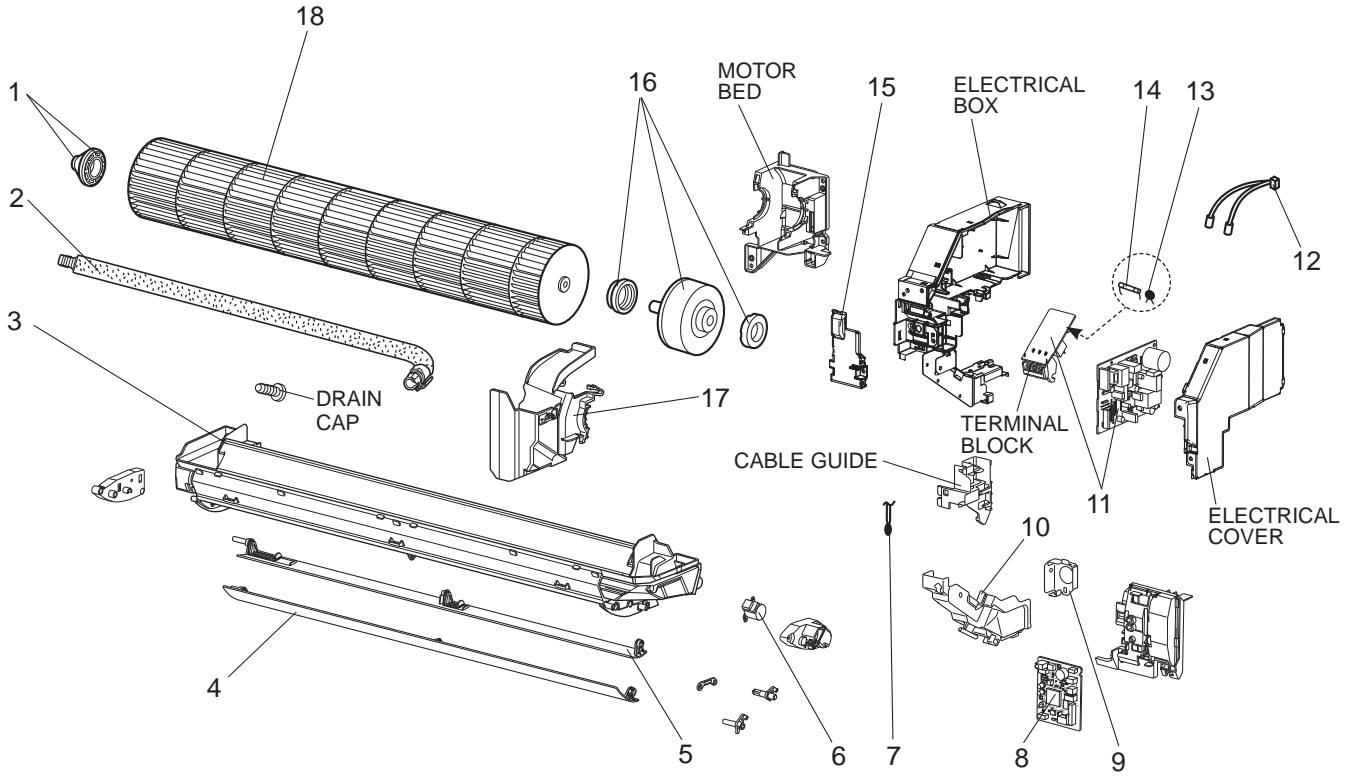

1-3. INDOOR UNIT ELECTRICAL PARTS AND FUNCTIONAL PARTS

1. The part quantity below indicates the required number of pieces per unit.

No.	Part No.	Part name	MSZ-JP09WA-U1	MSZ-JP12WA-U1	MSZ-JP09WA-U2	MSZ-JP12WA-U2	Symbol in Wiring Diagram	Remarks
1	U01 A02 510	BEARING MOUNT ASSEMBLY	1	1	1	1		Includes sleeve bearing
2	U01 A01 702	DRAIN HOSE	1	1	1	1		
3	U01 A01 235	NOZZLE ASSEMBLY	1	1	1	1		
4	U01 A01 040	VANE-UPPER	1	1	1	1		
5	U01 A01 041	VANE-LOWER	1	1	1	1		
6	U01 A01 303	VANE MOTOR	1	1	1	1	MV	UP & DOWN
7	U01 A01 308	ROOM TEMPERATURE THERMISTOR	1	1			RT11	
7	U01 A08 308	ROOM TEMPERATURE THERMISTOR			1	1	RT11	
8	U01 A35 452	ELECTRONIC CONTROL P.C. BOARD	1					
8	U01 A36 452	ELECTRONIC CONTROL P.C. BOARD		1				
8	U01 A58 452	ELECTRONIC CONTROL P.C. BOARD			1			
8	U01 A59 452	ELECTRONIC CONTROL P.C. BOARD				1		
9	U01 A01 978	CONDUIT PLATE	1	1	1	1		
10	U01 A01 979	CONDUIT COVER	1	1	1	1		
11	U01 A02 440	POWER P.C. BOARD	1	1	1	1		Includes TERMINAL BLOCK with TERMINAL P.C. BOARD
12	U01 A01 307	INDOOR COIL THERMISTOR	1	1			RT12, RT13	
12	U01 A09 308	INDOOR COIL THERMISTOR			1	1	RT12, RT13	
13	U01 A02 385	VARISTOR	1	1	1	1	NR11	
14	U01 A01 382	FUSE	1	1	1	1	F11	T3.15AL250V
15	U01 A01 784	V.A. CLAMP	1	1	1	1		
16	U01 A02 300	INDOOR FAN MOTOR	1	1	1	1	MF	RC0J30-□□ Includes FAN MOTOR RUBBER MOUNT (2 PCS/SET)
17	U01 A01 333	MOTOR BAND	1	1	1	1		
18	U01 A01 302	LINE FLOW FAN	1	1	1	1		

MSZ-JP09WA MSZ-JP12WA
1-4. INDOOR UNIT HEAT EXCHANGER

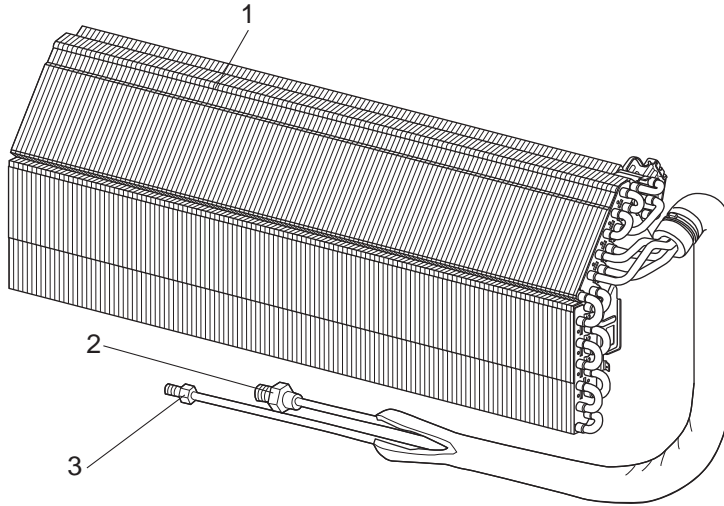

1-4. INDOOR UNIT HEAT EXCHANGER

1. The part quantity below indicates the required number of pieces per unit.

No.	Part No.	Part name	MSZ-JP09WA- <input type="checkbox"/> U1	MSZ-JP12WA- <input type="checkbox"/> U1	MSZ-JP09WA- <input type="checkbox"/> U2	MSZ-JP12WA- <input type="checkbox"/> U2	Symbol in Wiring Diagram	Remarks
1	U01 A03 620	INDOOR HEAT EXCHANGER	1	1	1	1		
2	U01 A01 666	UNION GAS	1	1	1	1		ø3/8 (ø9.52)
3	U01 A01 667	UNION LIQUID	1	1	1	1		ø1/4 (ø6.35)

2-1. AIR CLEANING FILTER

Every 3 months:

- Remove dirt by a vacuum cleaner.

When dirt cannot be removed by vacuum cleaning:

- Soak the filter and its frame in lukewarm water before rinsing it.
- After washing, dry it well in shade.

Every year:

- Replace it with a new air cleaning filter for best performance.

NOTE 1: Clean the filters regularly for best performance and to reduce power consumption.

NOTE 2: Dirty filters cause condensation in the air conditioner which will contribute to the growth of fungi such as mold. It is therefore recommended to clean air filters every 2 weeks.

(ANTI-ALLERGY ENZYME FILTER)

Model	Part No.
MSZ-JP09WA MSZ-JP12WA	MAC-408FT-E

Pull to remove from the air filter

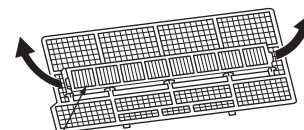

Air cleaning filter
(Blue bellows type)

MITSUBISHI ELECTRIC CORPORATION

HEAD OFFICE: TOKYO BUILDING, 2-7-3, MARUNOUCHI, CHIYODA-KU, TOKYO 100-8310, JAPAN

© Copyright 2018 MITSUBISHI ELECTRIC CORPORATION

Issued: Mar. 2023. No. OBB820 REVISED EDITION-A

Published: Nov. 2018. No. OBB820

Made in Japan

Specifications are subject to change without notice.