

PARTS CATALOG

**[Model Name]
<Outdoor unit>**

MXZ-8C48NA2

MXZ-8C60NA2

MXZ-4C36NAHZ2

MXZ-5C42NAHZ2

MXZ-8C48NAHZ2

<Branch box>

PAC-MKA32BC

PAC-MKA52BC

[Service Ref.]

MXZ-8C48NA2-U1

MXZ-8C60NA2-U1

MXZ-4C36NAHZ2-U1

MXZ-5C42NAHZ2-U1

MXZ-8C48NAHZ2-U1

PAC-MKA32BC

PAC-MKA52BC

Revision:

- Parts catalog has been updated in REVISED EDITION-A.

OCB730 is void.

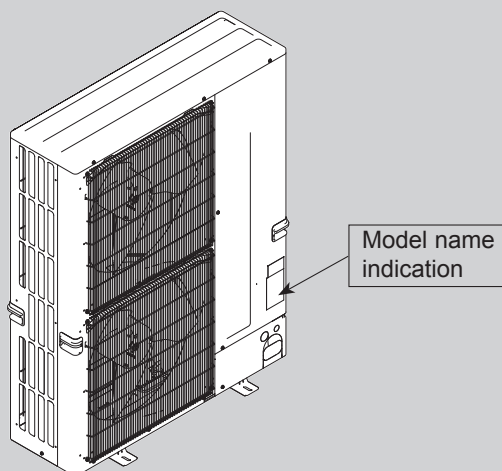

OUTDOOR UNIT: MXZ-4C36NAHZ2-U1

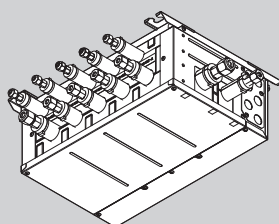

BRANCH BOX: PAC-MKA52BC

CONTENTS

1. SERVICE PARTS LIST..... 2
2. OPTIONAL PARTS..... 12

SERVICE MANUAL (OCH730)

1

SERVICE PARTS LIST

1-1. OUTDOOR UNIT STRUCTURAL PARTS

MXZ-8C48NA2-U1
MXZ-8C60NA2-U1
MXZ-4C36NAHZ2-U1
MXZ-5C42NAHZ2-U1
MXZ-8C48NAHZ2-U1

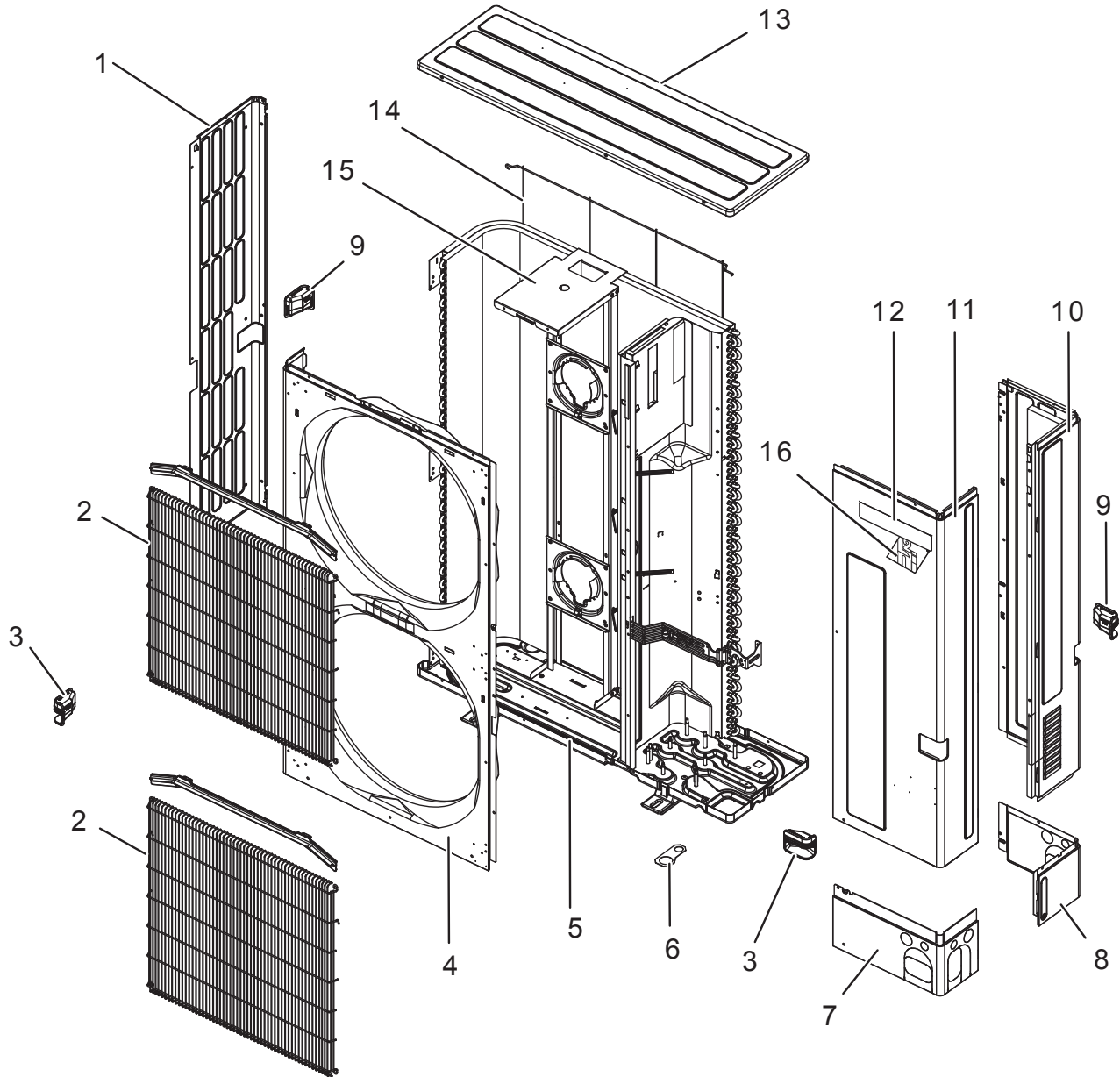

1. The part quantity below indicates the required number of pieces per unit.
2. The circled No. indicates that the part is not shown in the figure.

No.	Parts No.	Parts Name	MXZ-8C48NA2-U1	MXZ-8C60NA2-U1	MXZ-4C36NAHZ2-U1	MXZ-5C42NAHZ2-U1	MXZ-8C48NAHZ2-U1	Remarks
1	R 0 1 E 3 0 6 6 2	SIDE PANEL (L)	1	1	1	1	1	
2	R 0 1 E 7 3 6 9 1	WIRE GRILLE	2	2	2	2	2	
3	R 0 1 E 0 5 6 5 5	HANDLE (FRONT)	2	2	2	2	2	
4	R 0 1 E 2 3 6 6 8	FRONT PANEL	1	1	1	1	1	
5	R 0 1 E 5 3 6 8 6	BASE ASSY	1	1	1	1	1	
6	T 7 W E 0 5 6 1 7	CONDUIT PLATE	1	1	1	1	1	
7	R 0 1 E 3 5 6 5 8	COVER PANEL (FRONT)	1	1	1	1	1	
8	R 0 1 E 3 6 6 5 8	COVER PANEL (REAR)	1	1	1	1	1	
9	R 0 1 E 0 6 6 5 5	HANDLE (REAR)	2	2	2	2	2	
10	R 0 1 E 7 4 6 6 1	SIDE PANEL (R)	1	1	1	1	1	
11	T 7 W E 2 4 6 6 8	SERVICE PANEL	1	1	1	1	1	
12	R 0 1 A 1 3 0 0 5	BRAND LABEL	1	1	1	1	1	
13	R 0 1 E 3 6 6 4 1	TOP PANEL	1	1	1	1	1	
14	R 0 1 E 1 0 6 9 8	REAR GUARD	1	1	1	1	1	
15	R 0 1 E 5 9 1 3 0	MOTOR SUPPORT	1		1	1	1	
15	R 0 1 E 6 0 1 3 0	MOTOR SUPPORT		1				
16	T 7 W A 1 0 0 0 5	LABEL (H2I)			1	1	1	

1-2. OUTDOOR UNIT FUNCTIONAL AND ELECTRICAL PARTS

MXZ-8C48NA2-U1

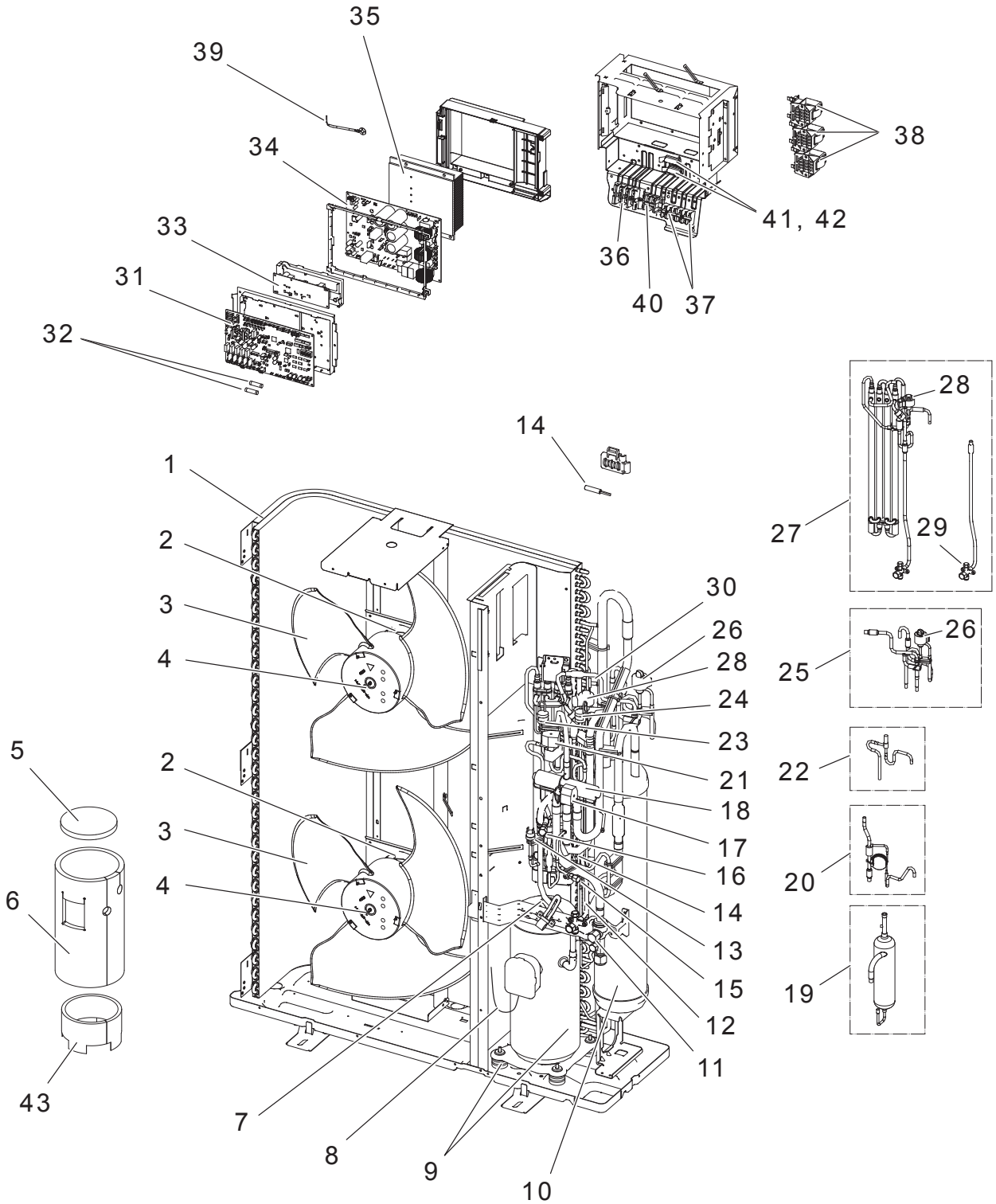

1. The part quantity below indicates the required number of pieces per unit.
2. The circled No. indicates that the part is not shown in the figure.

No.	Parts No.	Parts Name	MXZ-8C48NA2-U1	Wiring Diagram Symbol	Remarks
1	R 0 1 R 6 5 4 0 8	HEAT EXCHANGER	1		
2	T 7 W A 1 0 2 2 1	FAN MOTOR	2	MF1, MF2	
3	R 0 1 E 1 6 1 1 5	PROPELLER FAN/D550	2		
4	R 0 1 E 1 6 0 9 7	CAP NUT (MEC) M6	2		
5	R 0 1 A 5 7 6 0 2	COMP FELT (TOP)	1		
6	T 7 W B 0 4 6 0 2	COMP FELT-B/ANB33FN	1		
7	R 0 1 E 3 6 2 0 1	THERMISTOR (SHELL)	1	TH4 (Compressor)	
8	R 0 1 C 1 1 5 1 0	LEAD ASSY COMP	1		
9	T 9 7 4 7 7 0 7 7	COMPRESSOR	1	MC	ANB33FNHMT, Includes RUBBER MOUNT
10	R 0 1 E 8 1 4 4 0	ACCUMULATOR	1		
11	T 7 W E 1 1 4 1 1	BALL VALVE & STRAINER	1		5/8
12	R 0 1 M 3 0 2 0 2	THERMISTOR	1	TH2 (HIC Pipe)	
13	T 7 W E 1 5 2 0 8	H. P. SWITCH UL4.14MPA	1	63H	
14	R 0 1 M 3 1 2 0 2	THERMISTOR W	1	TH6 (Suction Pipe), TH7 (Ambient)	Combined Port
15	T 7 W E 1 3 4 1 3	CHARGE PLUG/LB54	1		Lo
16	R 0 1 E 1 2 4 1 3	CHARGE PLUG/LB90	1		Hi
17	T 7 W F 0 0 2 4 2	SOLENOID COIL (21S4)	1	21S4	Includes SCREW
18	R 0 1 E 4 0 4 0 3	4WAY VALVE	1	21S4	
19	R 0 1 E 1 6 4 9 0	OIL SEPARATOR	1		
20	R 0 1 E 0 2 4 2 6	CT ASSY	1		
21	T 7 W E 9 1 2 4 2	SOLENOID COIL (SV)	1	SV1	Includes SCREW
22	T 7 W E 1 1 4 2 8	SV1 ASSY	1	SV1	
23	R 0 1 E 1 4 2 0 8	H. P. SENSOR	1	63HS	
24	R 0 1 E 0 4 2 0 9	LOW PRESSURE SENSOR	1	63LS	
25	R 0 1 R 2 7 4 0 1	LEV ASSY-A	1	LEV-A	
26	R 0 1 H R 1 2 4 2	COIL (LEV)/XAP-5P WH	1	LEV-A	
27	T 7 W B 0 7 4 0 1	HIC & LEV-B ASSY	1	LEV-B	
28	R 0 1 H 5 8 2 4 2	COIL (LEV)/XAP-5P RED	1	LEV-B	
29	T 7 W E 1 5 4 1 0	STOP VALVE ASSY-3/8F	1		3/8
30	R 0 1 H 8 7 2 0 2	THERMISTOR	1	TH3 (Outdoor Liquid Pipe)	
31	R 0 1 M 0 3 3 5 0	CONTROLLER BOARD	1	MULTI.B.	
32	R 0 1 E 1 4 2 3 9	FUSE 6.3 A 250 V	2	F1, F2	6.3 A 250 V
33	R 0 1 E 0 7 3 1 1	M-NET POWER BOARD	1	M-NET P.B.	
34	R 0 1 M 0 5 3 5 3	POWER BOARD	1	P.B.	
35	R 0 1 A 2 2 3 7 1	HEAT SINK	1		Includes SCREWS
36	T 7 W 6 0 3 2 4 6	T.B./L1.L2.GR	1	TB1	3P (L1, L2, GR)
37	R 0 1 E 2 7 2 4 6	T.B./M1.M2.S	2	TB3, TB7	3P (M1, M2, S)
38	R 0 1 E 5 6 2 5 9	REACTOR	3	DCL	
39	R 0 1 M 1 5 2 0 2	THERMISTOR (HS)	1	TH8	
40	T 7 W E 5 7 7 1 6	T.B./B1.B2	1	TB1B	2P (B1, B2)
41	R 0 1 E 2 0 2 3 9	FUSE 20 A 250 V	2	FUSE1, 2	20 A 250 V
42	R 0 1 3 0 L 2 4 1	FUSE HOLDER	2		
43	R 0 1 U 0 0 6 0 2	COMP FELT-U/ANB	1		

1-2. OUTDOOR UNIT FUNCTIONAL AND ELECTRICAL PARTS

MXZ-8C60NA2-U1

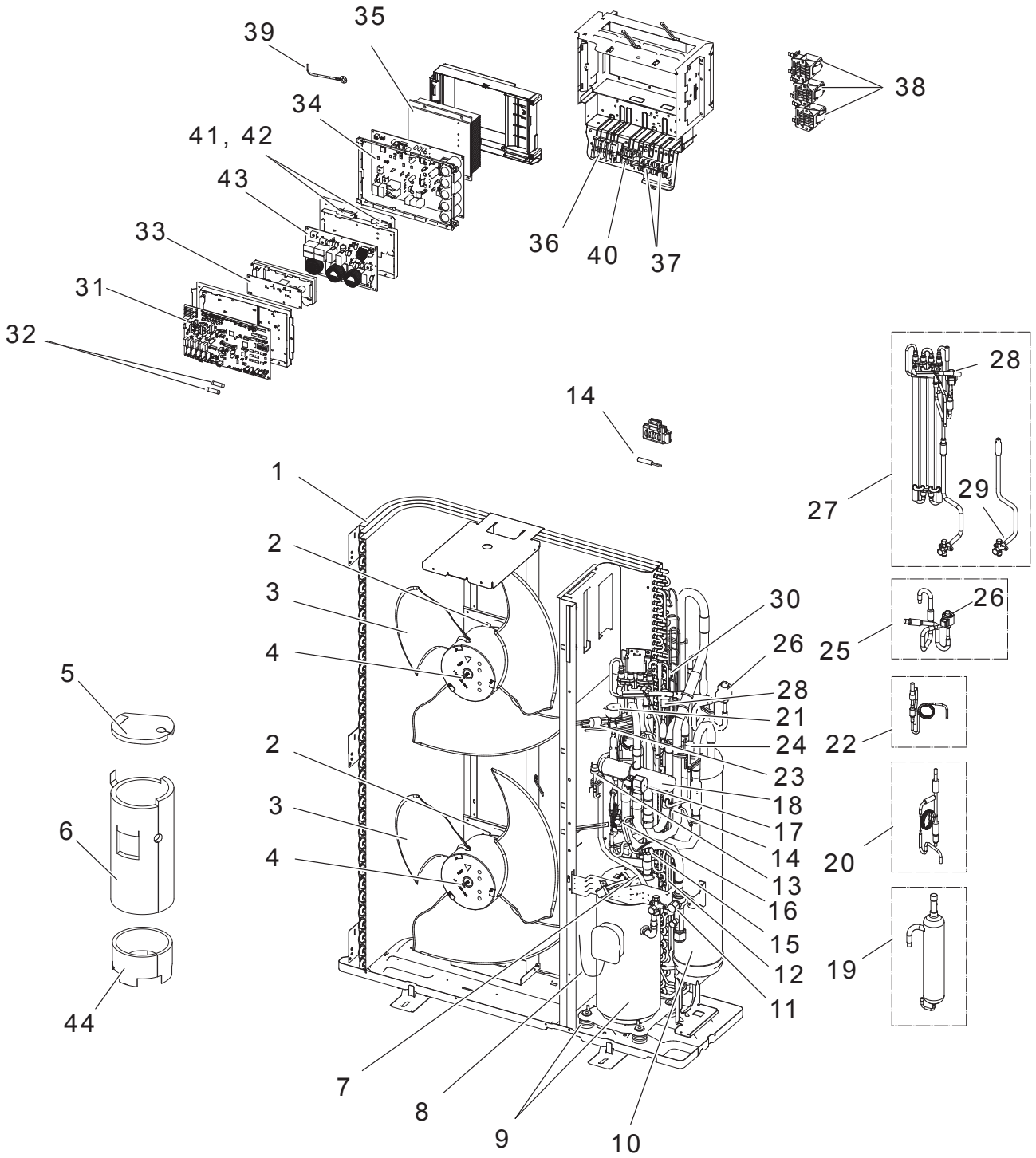

1. The part quantity below indicates the required number of pieces per unit.
2. The circled No. indicates that the part is not shown in the figure.

No.	Parts No.	Parts Name	MXZ-8C60NA2-U1	Wiring Diagram Symbol	Remarks
1	R 0 1 H 6 6 4 0 8	HEAT EXCHANGER	1		
2	T 7 W A 1 2 2 2 1	FAN MOTOR	2	MF1, MF2	
3	R 0 1 E 1 6 1 1 5	PROPELLER FAN/D550	2		
4	R 0 1 E 1 6 0 9 7	CAP NUT (MEC) M6	2		
5	T 7 W A 1 5 6 0 2	COMP FELT (TOP)	1		
6	T 7 W B 0 5 6 0 2	COMP FELT-B/ANB52	1		
7	R 0 1 E 3 6 2 0 1	THERMISTOR (SHELL)	1	TH4 (Compressor)	
8	R 0 1 C 1 2 5 1 0	LEAD ASSY COMP	1		
9	T 9 7 4 7 9 0 7 7	COMPRESSOR	1	MC	ANB52FYDMT, Includes RUBBER MOUNT
10	R 0 1 H 6 7 4 4 0	ACCUMULATOR	1		
11	T 7 W E 1 3 4 1 1	BALL VALVE & STRAINER	1		3/4
12	R 0 1 M 3 0 2 0 2	THERMISTOR	1	TH2 (HIC Pipe)	
13	T 7 W E 1 5 2 0 8	H. P. SWITCH UL4.14MPA	1	63H	
14	R 0 1 M 3 1 2 0 2	THERMISTOR W	1	TH6 (Suction Pipe), TH7 (Ambient)	Combined Port
15	R 0 1 E 1 2 4 1 3	CHARGE PLUG/LB90	1		Lo
16	R 0 1 E 1 2 4 1 3	CHARGE PLUG/LB90	1		Hi
17	T 7 W F 0 0 2 4 2	SOLENOID COIL (21S4)	1	21S4	Includes SCREW
18	T 7 W E 0 9 4 0 3	4WAY VALVE	1	21S4	
19	R 0 1 E 1 4 4 9 0	OIL SEPARATOR	1		
20	T 7 W H 0 6 4 2 6	CT ASSY	1		
21	T 7 W E 9 1 2 4 2	SOLENOID COIL (SV)	1	SV1	Includes SCREW
22	T 7 W E 1 2 4 2 8	SV1 ASSY	1	SV1	
23	R 0 1 E 1 4 2 0 8	H. P. SENSOR	1	63HS	
24	R 0 1 E 0 4 2 0 9	LOW PRESSURE SENSOR	1	63LS	
25	T 7 W H 6 1 4 0 1	LEV ASSY-A/C-HIC	1	LEV-A	
26	R 0 1 H 3 9 2 4 2	COIL (LEV)/XAP-5P WH	1	LEV-A	
27	T 7 W B 0 8 4 0 1	HIC & LEV-B ASSY	1	LEV-B	
28	R 0 1 H 5 8 2 4 2	COIL (LEV)/XAP-5P RED	1	LEV-B	
29	T 7 W E 1 6 4 1 0	STOP VALVE ASSY-3/8F	1		3/8
30	R 0 1 H 8 7 2 0 2	THERMISTOR	1	TH3 (Outdoor Liquid Pipe)	
31	T 7 W M 0 8 3 1 5	CONTROLLER BOARD	1	MULTI.B.	
32	R 0 1 E 1 4 2 3 9	FUSE 6.3A 250V	2	F1, F2	6.3A 250V
33	R 0 1 E 0 7 3 1 1	M-NET POWER BOARD	1	M-NET P.B.	
34	T 7 W M 0 1 3 2 3	POWER BOARD	1	P.B.	
35	R 0 1 A 2 3 3 7 1	HEAT SINK	1		Includes SCREWS
36	T 7 W 6 0 3 2 4 6	T.B./L1.L2.GR	1	TB1	3P (L1, L2, GR)
37	R 0 1 E 2 7 2 4 6	T.B./M1.M2.S	2	TB3, TB7	3P (M1, M2, S)
38	R 0 1 E 5 6 2 5 9	REACTOR	3	DCL	
39	R 0 1 M 1 6 2 0 2	THERMISTOR (HS)	1	TH8	
40	T 7 W E 5 7 7 1 6	T.B./B1.B2	1	TB1B	2P (B1, B2)
41	R 0 1 E 2 0 2 3 9	FUSE 20 A 250 V	2	FUSE1, 2	20 A 250 V
42	R 0 1 3 0 L 2 4 1	FUSE HOLDER	2		
43	T 7 W E 3 9 3 4 6	NOISE FILTER	1	N.F.	
44	R 0 1 U 0 0 6 0 2	COMP FELT-U/ANB	1		

1-2. OUTDOOR UNIT FUNCTIONAL AND ELECTRICAL PARTS

MXZ-4C36NAHZ2-U1
 MXZ-5C42NAHZ2-U1
 MXZ-8C48NAHZ2-U1

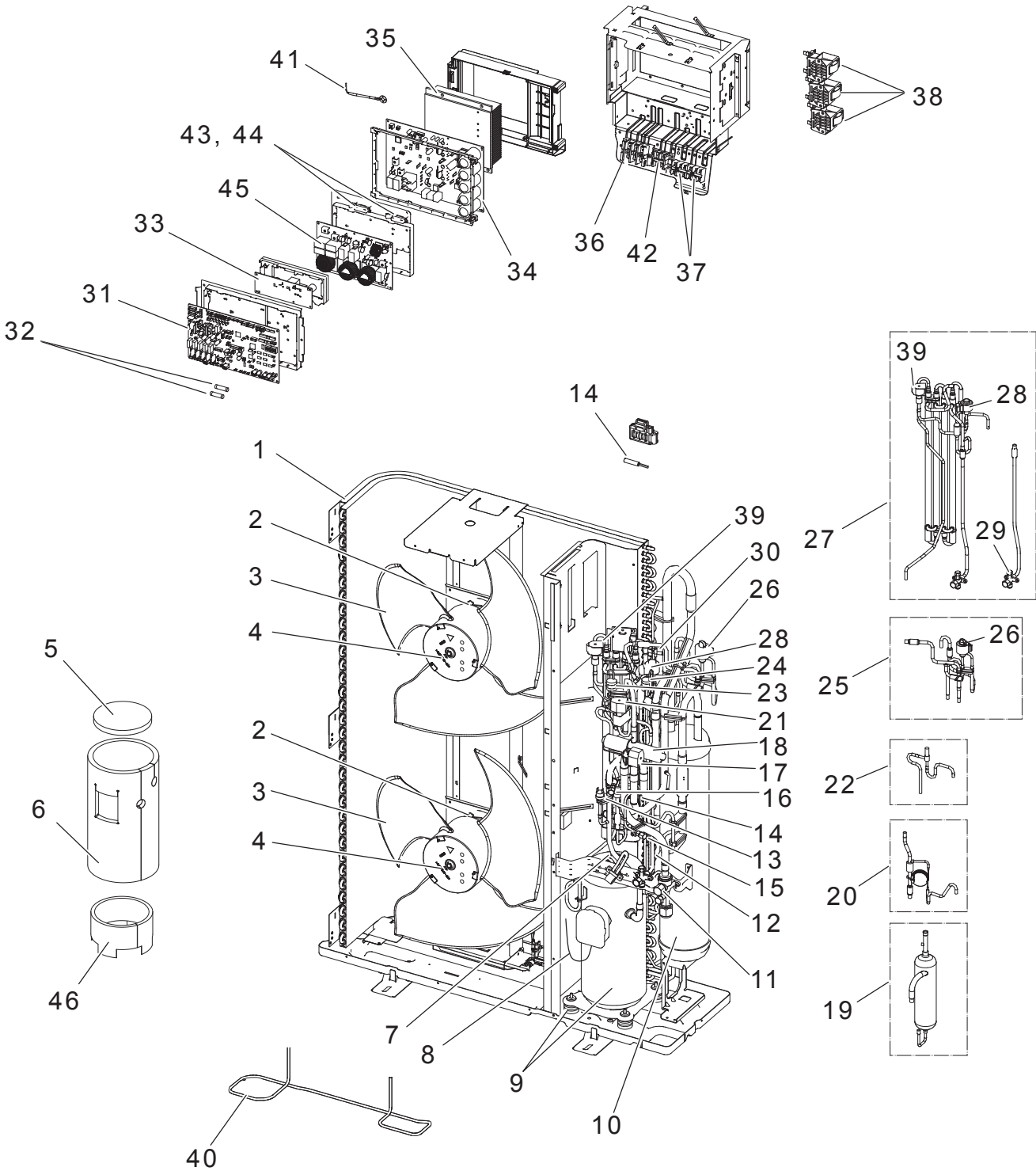

1. The part quantity below indicates the required number of pieces per unit.
2. The circled No. indicates that the part is not shown in the figure.

No.	Parts No.	Parts Name	MXZ-4C36NAHZ2-U1	MXZ-5C42NAHZ2-U1	MXZ-8C48NAHZ2-U1	Wiring Diagram Symbol	Remarks
1	R 01 R 65 408	HEAT EXCHANGER	1	1	1		
2	T 7W A 10 221	FAN MOTOR	2	2	2	MF1, MF2	
3	R 01 E 16 115	PROPELLER FAN/D550	2	2	2		
4	R 01 E 16 097	CAP NUT (MEC) M6	2	2	2		
5	R 01 A 57 602	COMP FELT (TOP)	1	1	1		
6	T 7W B 03 602	COMP FELT-B/ANB33FJ	1	1	1		
7	R 01 E 36 201	THERMISTOR (SHELL)	1	1	1	TH4 (Compressor)	
8	R 01 C 13 510	LEAD ASSY COMP	1	1	1		
9	T 97 443 077	COMPRESSOR	1	1	1	MC	ANB33FJSMT, Includes RUBBER MOUNT
10	R 01 E 81 440	ACCUMULATOR	1	1	1		
11	T 7W E 11 411	BALL VALVE & STRAINER	1	1	1		5/8
12	R 01 M 30 202	THERMISTOR	1	1	1	TH2 (HIC Pipe)	
13	T 7W E 15 208	H. P. SWITCH UL4.14MPA	1	1	1	63H	
14	R 01 M 31 202	THERMISTOR W	1	1	1	TH6 (Suction Pipe), TH7 (Ambient)	Combined Port
15	T 7W E 13 413	CHARGE PLUG/LB54	1	1	1		Lo
16	R 01 E 12 413	CHARGE PLUG/LB90	1	1	1		Hi
17	T 7W F 00 242	SOLENOID COIL (21S4)	1	1	1	21S4	Includes SCREW
18	R 01 E 40 403	4WAY VALVE	1	1	1	21S4	
19	R 01 E 16 490	OIL SEPARATOR	1	1	1		
20	R 01 E 02 426	CT ASSY	1	1	1		
21	T 7W E 91 242	SOLENOID COIL (SV)	1	1	1	SV1	Includes SCREW
22	T 7W E 11 428	SV1 ASSY	1	1	1	SV1	
23	R 01 E 14 208	H. P. SENSOR	1	1	1	63HS	
24	R 01 E 04 209	LOW PRESSURE SENSOR	1	1	1	63LS	
25	R 01 R 27 401	LEV ASSY-A	1	1	1	LEV-A	
26	R 01 HR 1 242	COIL (LEV)/XAP-5P WH	1	1	1	LEV-A	
27	T 7W B 09 401	HIC & LEV-B ASSY	1	1	1	LEV-B	
28	R 01 H 58 242	COIL (LEV)/XAP-5P RED	1	1	1	LEV-B	
29	T 7W E 15 410	STOP VALVE ASSY-3/8F	1	1	1		3/8
30	R 01 H 87 202	THERMISTOR	1	1	1	TH3 (Outdoor Liquid Pipe)	
31	R 01 M 03 350	CONTROLLER BOARD	1	1	1	MULTI.B.	
32	R 01 E 14 239	FUSE 6.3A 250V	2	2	2	F1, F2	6.3A 250V
33	R 01 E 07 311	M-NET POWER BOARD	1	1	1	M-NET P.B.	
34	T 7W M 01 323	POWER BOARD	1	1	1	P.B.	
35	R 01 A 23 371	HEAT SINK	1	1	1		Includes SCREWS
36	T 7W 603 246	T.B./L1.L2.GR	1	1	1	TB1	3P (L1, L2, GR)
37	R 01 E 27 246	T.B./M1.M2.S	2	2	2	TB3, TB7	3P (M1, M2, S)
38	R 01 E 56 259	REACTOR	3	3	3	DCL	
39	T 7W E 72 242	SOLENOID COIL (SV)	1	1	1	SV2	Includes SCREW
40	T 7W B 03 300	BASE HEATER	1	1	1	BH, THP	
41	R 01 M 16 202	THERMISTOR (HS)	1	1	1	TH8	
42	T 7W E 57 716	T.B./B1.B2	1	1	1	TB1B	2P (B1, B2)
43	R 01 E 20 239	FUSE 20 A 250 V	2	2	2	FUSE1, 2	20 A 250 V
44	R 01 30L 241	FUSE HOLDER	2	2	2		
45	T 7W E 39 346	NOISE FILTER	1	1	1	N.F.	
46	R 01 U 00 602	COMP FELT-U/ANB	1	1	1		

1-3. BRANCH BOX FUNCTIONAL PARTS
PAC-MKA32BC
PAC-MKA52BC

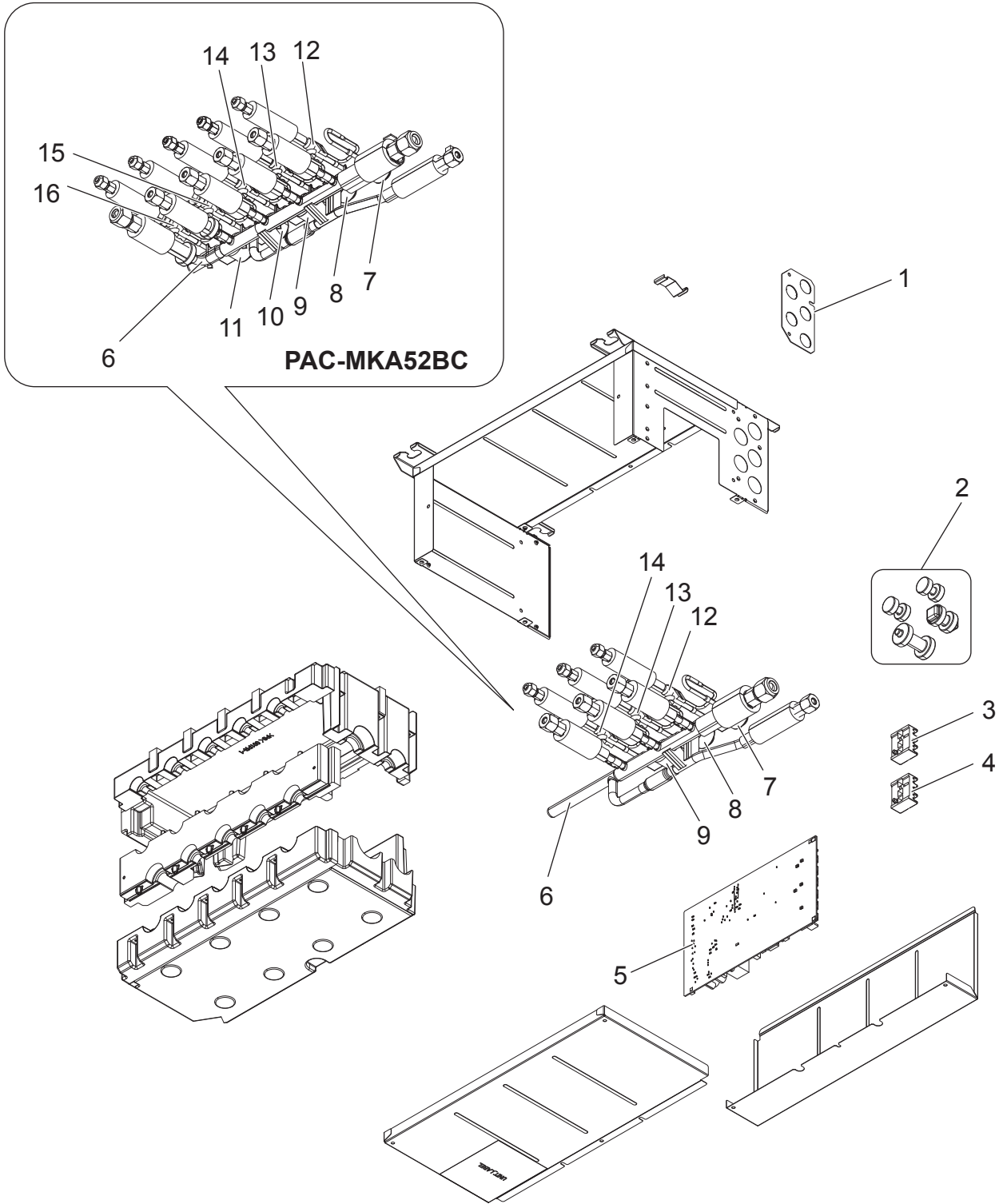

1. The part quantity below indicates the required number of pieces per unit.
2. The circled No. indicates that the part is not shown in the figure.

No.	Parts No.	Parts Name	PAC-MKA32BC	PAC-MKA52BC	Wiring Diagram Symbol	Remarks
1	T7W E06 617	CONDUIT PLATE	1	1		
2	R01 E04 124	BUSH SET	1			
3	T7W E60 716	T.B./M1.M2.S	1	1	TB5	3P (M1, M2, S)
4	T7W E59 716	T.B./L1.L2	1	1	TB2B	2P (L1, L2)
5	T7W F23 310	CONTROLLER BOARD	1		B.C.	
5	T7W F24 310	CONTROLLER BOARD		1	B.C.	
6	T7W F07 401	LEV ASSY MKA32BC	1			Includes coils
6	T7W F08 401	LEV ASSY MKA52BC		1		Includes coils
7	T7W E73 242	COIL(LEV)/XAP-5P WH	1	1	LEV-A (WHITE)	
8	R01 H38 242	COIL(LEV)/XAP-5P RED	1	1	LEV-B (RED)	
9	T7W E80 242	COIL(LEV)/XAP-5P BLU	1	1	LEV-C (BLUE)	
10	T7W E76 242	COIL(LEV)/XAP-5P BLK		1	LEV-D (BLACK)	
11	T7W E77 242	COIL(LEV)/XAP-5P GRN		1	LEV-E (GREEN)	
12	T7W E66 202	THERMISTOR-A	1	1	TH-A (WHITE)	
13	T7W E67 202	THERMISTOR-B	1	1	TH-B (RED)	
14	T7W E68 202	THERMISTOR-C	1	1	TH-C (BLUE)	
15	T7W E69 202	THERMISTOR-D		1	TH-D (BLACK)	
16	T7W E70 202	THERMISTOR-E		1	TH-E (GREEN)	
17	T7W H18 392	LEAD WIRE SET	1	1		
18	R01 E14 239	FUSE 6.3 A 250 V	1	1	F1	6.3 A 250 V
19	R01 E21 239	FUSE 10 A 250 V	2	3	F2,F3, (F4)	10 A 250 V
20	R01 E09 660	PIPE COVER SET	1	1		STEM
21	R01 E08 660	PIPE COVER SET	1	1		BRANCH

2

OPTIONAL PARTS

2-1. FOR OUTDOOR UNIT

Parts name	Parts No.
DRAIN SOCKET*	PAC-SG61DS-E
AIR OUTLET GUIDE*¹	PAC-SH96SG-E
DRAIN PAN*	PAC-SH97DP-E
2-BRANCH PIPE (Joint) (In case of using 2-branch boxes)*²	MSDD-50AR-E (flare)
	MSDD-50BR-E (brazing)
BASE HEATER	PAC-SJ20BH-E

* It cannot be used with a base heater.

*¹ Need 2 pieces.

*² Select a joint according to the connection method.

2-2. FOR BRANCH BOX

Different-diameter joint

Part No.	Connected pipes diameter	Diameter A	Diameter B
	mm	mm	mm
MAC-A454JP-E	ø9.52 → ø12.7	ø9.52	ø12.7
MAC-A455JP-E	ø12.7 → ø9.52	ø12.7	ø9.52
MAC-A456JP-E	ø12.7 → ø15.88	ø12.7	ø15.88
PAC-493PI	ø6.35 → ø9.52	ø6.35	ø9.52
PAC-SG76RJ-E	ø9.52 → ø15.88	ø9.52	ø15.88
PAC-SG75RJ-E	ø15.88 → ø19.05	ø15.88	ø19.05

<Reference>

Conversion formula

1/4 inch	ø6.35 mm
3/8 inch	ø9.52 mm
1/2 inch	ø12.7 mm
5/8 inch	ø15.88 mm
3/4 inch	ø19.05 mm

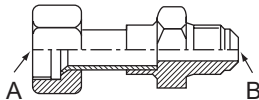

MITSUBISHI ELECTRIC CORPORATION

HEAD OFFICE: TOKYO BUILDING, 2-7-3, MARUNOUCHI, CHIYODA-KU, TOKYO 100-8310, JAPAN

©Copyright 2020 MITSUBISHI ELECTRIC CORPORATION
 Issued: Mar. 2020 No. OCB730 REVISED EDITION-A
 Published: Jan. 2020 No. OCB730
 Made in Japan

Specifications are subject to change without notice.