

PARTS CATALOG

[Model Name] <Outdoor unit>	[Service Ref.]
MXZ-8C48NA2	MXZ-8C48NA2-U1
MXZ-8C60NA2	MXZ-8C60NA2-U1
MXZ-4C36NAHZ2	MXZ-4C36NAHZ2-U1
MXZ-5C42NAHZ2	MXZ-5C42NAHZ2-U1
MXZ-8C48NAHZ2	MXZ-8C48NAHZ2-U1

<Branch box>

PAC-MKA52BC	PAC-MKA52BC
PAC-MKA32BC	PAC-MKA32BC
PAC-MKA53BC	PAC-MKA53BC
PAC-MKA33BC	PAC-MKA33BC

Revision:

- PAC-MKA53BC and PAC-MKA33BC have been added in REVISED EDITION-C.

OCB730B is void.

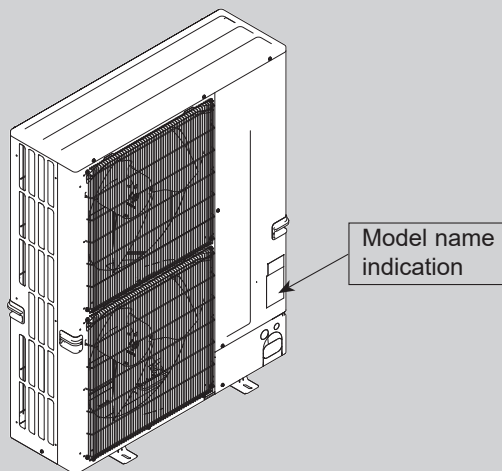
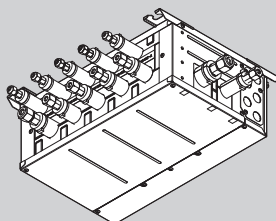
OUTDOOR UNIT: MXZ-4C36NAHZ2-U1

BRANCH BOX: PAC-MKA52BC

CONTENTS

1. SERVICE PARTS LIST 2
2. OPTIONAL PARTS 12

SERVICE MANUAL (OCH730)

1

SERVICE PARTS LIST

1-1. OUTDOOR UNIT STRUCTURAL PARTS

MXZ-8C48NA2-U1
MXZ-8C60NA2-U1
MXZ-4C36NAHZ2-U1
MXZ-5C42NAHZ2-U1
MXZ-8C48NAHZ2-U1

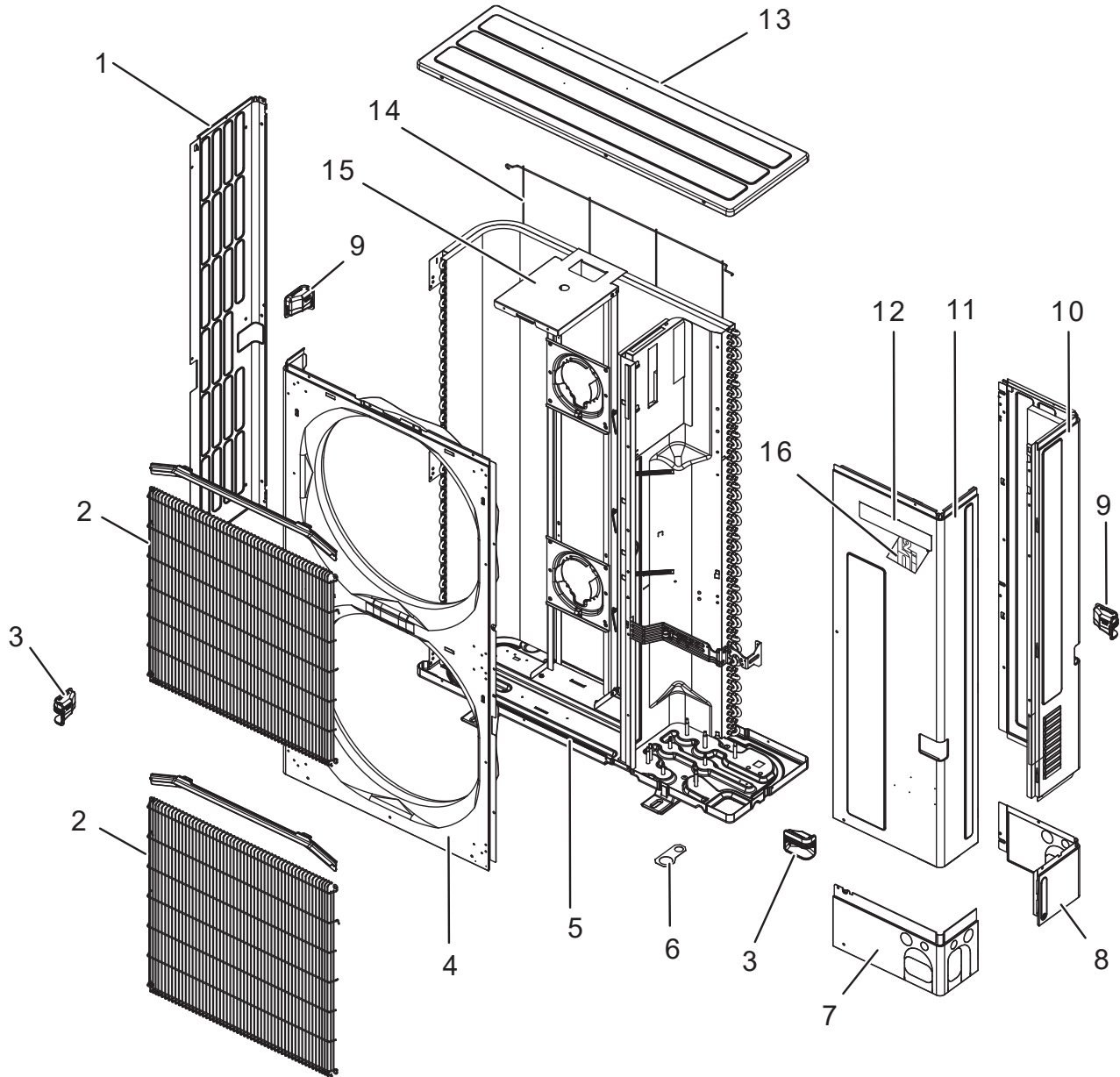

1. The part quantity below indicates the required number of pieces per unit.
2. The circled No. indicates that the part is not shown in the figure.

No.	Parts No.	Parts Name	MXZ-8C48NA2-U1	MXZ-8C60NA2-U1	MXZ-4C36NAHZ2-U1	MXZ-5C42NAHZ2-U1	MXZ-8C48NAHZ2-U1	Remarks
1	R 0 1 E 3 0 6 6 2	SIDE PANEL (L)	1	1	1	1	1	
2	R 0 1 E 7 3 6 9 1	WIRE GRILLE	2	2	2	2	2	
3	R 0 1 E 0 5 6 5 5	HANDLE (FRONT)	2	2	2	2	2	
4	R 0 1 E 2 3 6 6 8	FRONT PANEL	1	1	1	1	1	
5	R 0 1 E 5 3 6 8 6	BASE ASSY	1	1	1	1	1	
6	T 7 W E 0 5 6 1 7	CONDUIT PLATE	1	1	1	1	1	
7	R 0 1 E 3 5 6 5 8	COVER PANEL (FRONT)	1	1	1	1	1	
8	R 0 1 E 3 6 6 5 8	COVER PANEL (REAR)	1	1	1	1	1	
9	R 0 1 E 0 6 6 5 5	HANDLE (REAR)	2	2	2	2	2	
10	R 0 1 E 8 1 6 6 1	SIDE PANEL (R)	1					
10	R 0 1 E 7 4 6 6 1	SIDE PANEL (R)		1	1	1	1	
11	T 7 W E 2 8 6 6 8	SERVICE PANEL	1					
11	T 7 W E 2 5 6 6 8	SERVICE PANEL		1	1	1	1	
12	R 0 1 A 1 3 0 0 5	BRAND LABEL	1	1	1	1	1	
13	R 0 1 E 3 6 6 4 1	TOP PANEL	1	1	1	1	1	
14	R 0 1 E 1 0 6 9 8	REAR GUARD	1	1	1	1	1	
15	R 0 1 E 5 9 1 3 0	MOTOR SUPPORT	1		1	1	1	
15	R 0 1 E 6 0 1 3 0	MOTOR SUPPORT		1				
16	T 7 W A 1 0 0 0 5	LABEL (H2I)			1	1	1	

1-2. OUTDOOR UNIT FUNCTIONAL AND ELECTRICAL PARTS

MXZ-8C48NA2-U1

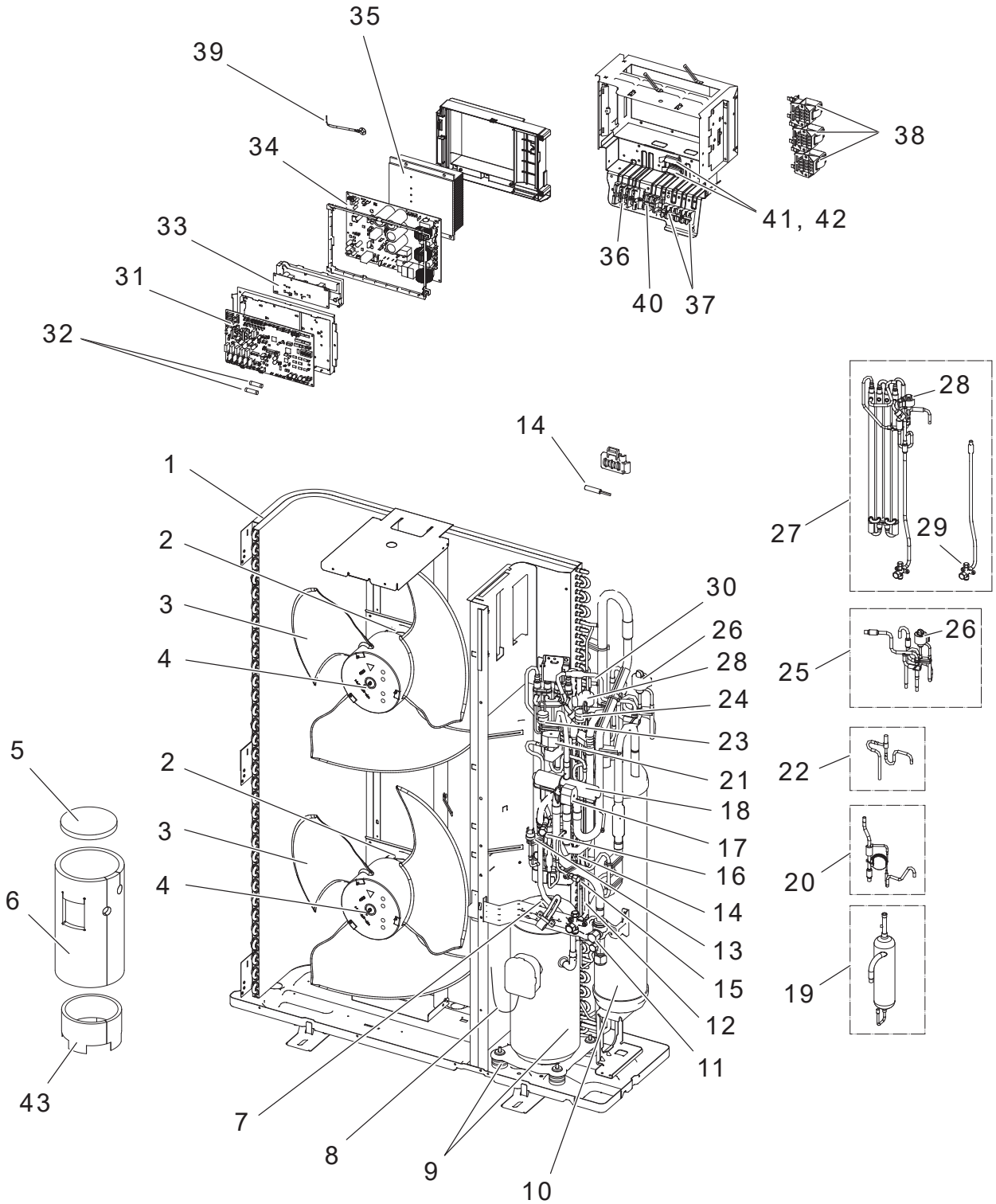

1. The part quantity below indicates the required number of pieces per unit.
2. The circled No. indicates that the part is not shown in the figure.

No.	Parts No.	Parts Name	MXZ-8C48NA2-U1	Wiring Diagram Symbol	Remarks
1	R 0 1 R 6 5 4 0 8	HEAT EXCHANGER	1		
2	T 7 W A 1 0 2 2 1	FAN MOTOR	2	MF1, MF2	
3	R 0 1 E 1 6 1 1 5	PROPELLER FAN/D550	2		
4	R 0 1 E 1 6 0 9 7	CAP NUT (MEC) M6	2		
5	R 0 1 A 5 7 6 0 2	COMP FELT (TOP)	1		
6	T 7 W B 0 4 6 0 2	COMP FELT-B/ANB33FN	1		
7	R 0 1 E 3 6 2 0 1	THERMISTOR (SHELL)	1	TH4 (Compressor)	
8	R 0 1 C 1 1 5 1 0	LEAD ASSY COMP	1		
9	T 9 7 4 7 7 0 7 7	COMPRESSOR	1	MC	ANB33FNHMT, Includes RUBBER MOUNT
10	R 0 1 E 8 1 4 4 0	ACCUMULATOR	1		
11	T 7 W E 1 1 4 1 1	BALL VALVE & STRAINER	1		5/8
12	R 0 1 M 3 0 2 0 2	THERMISTOR	1	TH2 (HIC Pipe)	
13	T 7 W E 1 5 2 0 8	H. P. SWITCH UL4.14MPA	1	63H	
14	R 0 1 M 3 1 2 0 2	THERMISTOR W	1	TH6 (Suction Pipe), TH7 (Ambient)	Combined Port
15	T 7 W E 1 3 4 1 3	CHARGE PLUG/LB54	1		Lo
16	R 0 1 E 1 2 4 1 3	CHARGE PLUG/LB90	1		Hi
17	T 7 W F 0 0 2 4 2	SOLENOID COIL (21S4)	1	21S4	Includes SCREW
18	R 0 1 E 4 0 4 0 3	4WAY VALVE	1	21S4	
19	R 0 1 E 1 6 4 9 0	OIL SEPARATOR	1		
20	R 0 1 E 0 2 4 2 6	CT ASSY	1		
21	T 7 W E 9 1 2 4 2	SOLENOID COIL (SV)	1	SV1	Includes SCREW
22	T 7 W E 1 1 4 2 8	SV1 ASSY	1	SV1	
23	R 0 1 E 1 4 2 0 8	H. P. SENSOR	1	63HS	
24	R 0 1 E 0 4 2 0 9	LOW PRESSURE SENSOR	1	63LS	
25	R 0 1 R 2 7 4 0 1	LEV ASSY-A	1	LEV-A	
26	R 0 1 H R 1 2 4 2	COIL (LEV)/XAP-5P WH	1	LEV-A	
27	T 7 W B 0 7 4 0 1	HIC & LEV-B ASSY	1	LEV-B	
28	R 0 1 H 5 8 2 4 2	COIL (LEV)/XAP-5P RED	1	LEV-B	
29	T 7 W E 1 5 4 1 0	STOP VALVE ASSY-3/8F	1		3/8
30	R 0 1 H 8 7 2 0 2	THERMISTOR	1	TH3 (Outdoor Liquid Pipe)	
31	R 0 1 M 2 4 3 5 0	CONTROLLER BOARD	1	MULTI.B.	
32	R 0 1 E 1 4 2 3 9	FUSE 6.3 A 250 V	2	F1, F2	6.3 A 250 V
33	R 0 1 E 0 7 3 1 1	M-NET POWER BOARD	1	M-NET P.B.	
34	R 0 1 M 0 5 3 5 3	POWER BOARD	1	P.B.	
35	R 0 1 A 2 2 3 7 1	HEAT SINK	1		Includes SCREWS
36	T 7 W 6 0 3 2 4 6	T.B./L1.L2.GR	1	TB1	3P (L1, L2, GR)
37	R 0 1 E 2 7 2 4 6	T.B./M1.M2.S	2	TB3, TB7	3P (M1, M2, S)
38	R 0 1 E 5 6 2 5 9	REACTOR	3	DCL	
39	R 0 1 M 1 3 2 0 2	THERMISTOR (HS)	1	TH8 (Heat Sink)	
40	T 7 W E 5 7 7 1 6	T.B./B1.B2	1	TB1B	2P (B1, B2)
41	R 0 1 E 2 0 2 3 9	FUSE 20 A 250 V	2	FUSE1, 2	20 A 250 V
42	R 0 1 3 0 L 2 4 1	FUSE HOLDER	2		
43	R 0 1 U 0 0 6 0 2	COMP FELT-U/ANB	1		

1-2. OUTDOOR UNIT FUNCTIONAL AND ELECTRICAL PARTS

MXZ-8C60NA2-U1

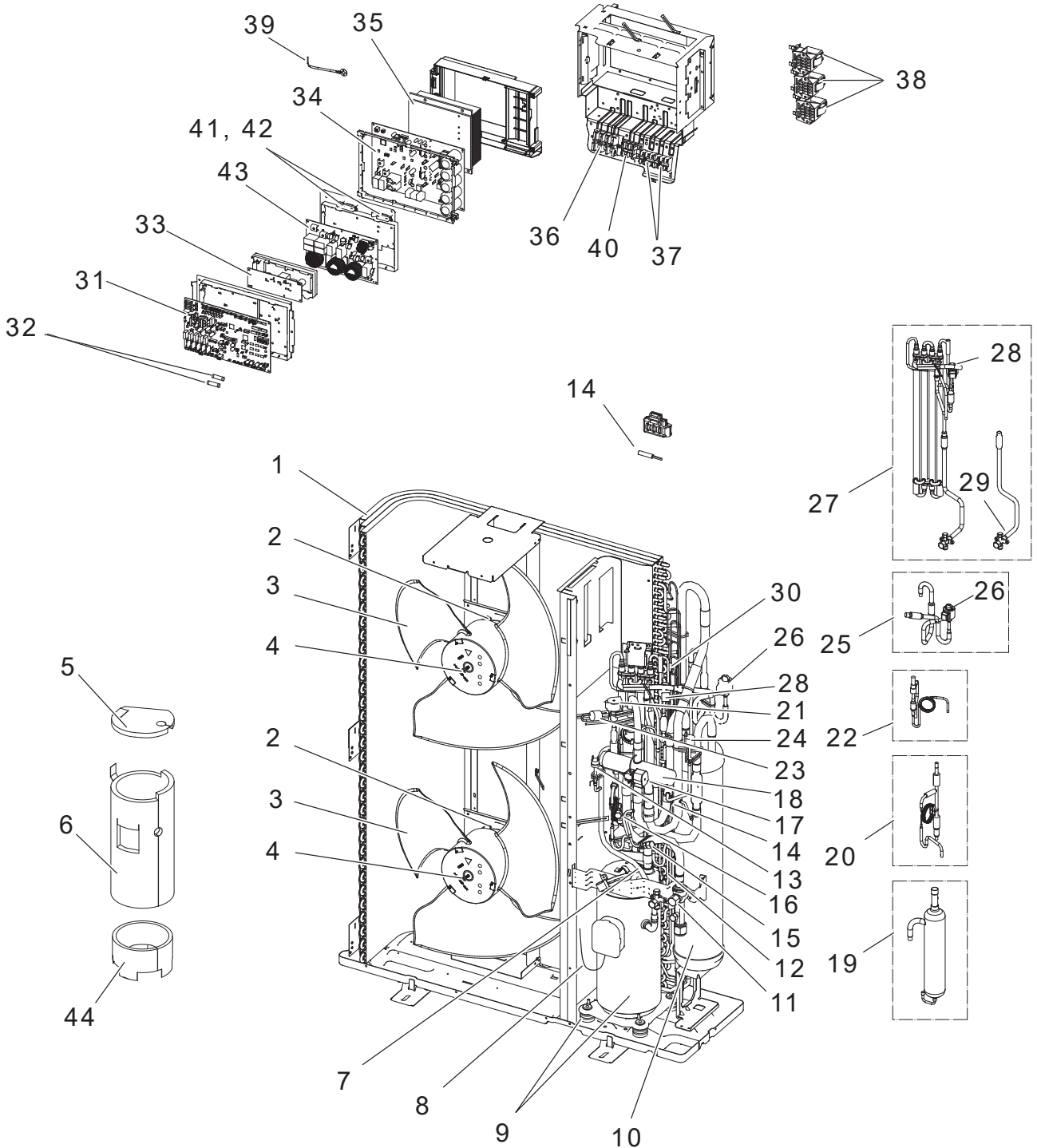

1. The part quantity below indicates the required number of pieces per unit.
2. The circled No. indicates that the part is not shown in the figure.

No.	Parts No.	Parts Name	MXZ-8C60NA2-U1	Wiring Diagram Symbol	Remarks
1	R 0 1 H 6 6 4 0 8	HEAT EXCHANGER	1		
2	T 7 W A 1 2 2 2 1	FAN MOTOR	2	MF1, MF2	
3	R 0 1 E 1 6 1 1 5	PROPELLER FAN/D550	2		
4	R 0 1 E 1 6 0 9 7	CAP NUT (MEC) M6	2		
5	T 7 W A 1 5 6 0 2	COMP FELT (TOP)	1		
6	T 7 W B 0 5 6 0 2	COMP FELT-B/ANB52	1		
7	R 0 1 E 3 6 2 0 1	THERMISTOR (SHELL)	1	TH4 (Compressor)	
8	R 0 1 C 1 2 5 1 0	LEAD ASSY COMP	1		
9	T 9 7 4 A 0 0 0 9	COMPRESSOR	1	MC	ANB52FYDMT, Includes RUBBER MOUNT
10	R 0 1 H 6 7 4 4 0	ACCUMULATOR	1		
11	T 7 W E 1 3 4 1 1	BALL VALVE & STRAINER	1		3/4
12	R 0 1 M 3 0 2 0 2	THERMISTOR	1	TH2 (HIC Pipe)	
13	T 7 W E 1 5 2 0 8	H. P. SWITCH UL4.14MPA	1	63H	
14	R 0 1 M 3 1 2 0 2	THERMISTOR W	1	TH6 (Suction Pipe), TH7 (Ambient)	Combined Port
15	R 0 1 E 1 2 4 1 3	CHARGE PLUG/LB90	1		Lo
16	R 0 1 E 1 2 4 1 3	CHARGE PLUG/LB90	1		Hi
17	T 7 W F 0 0 2 4 2	SOLENOID COIL (21S4)	1	21S4	Includes SCREW
18	T 7 W E 0 9 4 0 3	4WAY VALVE	1	21S4	
19	R 0 1 E 1 4 4 9 0	OIL SEPARATOR	1		
20	T 7 W H 0 6 4 2 6	CT ASSY	1		
21	T 7 W E 9 1 2 4 2	SOLENOID COIL (SV)	1	SV1	Includes SCREW
22	T 7 W E 1 2 4 2 8	SV1 ASSY	1	SV1	
23	R 0 1 E 1 4 2 0 8	H. P. SENSOR	1	63HS	
24	R 0 1 E 0 4 2 0 9	LOW PRESSURE SENSOR	1	63LS	
25	T 7 W H 6 1 4 0 1	LEV ASSY-A/C-HIC	1	LEV-A	
26	R 0 1 H 3 9 2 4 2	COIL (LEV)/XAP-5P WH	1	LEV-A	
27	T 7 W B 0 8 4 0 1	HIC & LEV-B ASSY	1	LEV-B	
28	R 0 1 H 5 8 2 4 2	COIL (LEV)/XAP-5P RED	1	LEV-B	
29	T 7 W E 1 6 4 1 0	STOP VALVE ASSY-3/8F	1		3/8
30	R 0 1 H 8 7 2 0 2	THERMISTOR	1	TH3 (Outdoor Liquid Pipe)	
31	T 7 W M 3 0 3 1 5	CONTROLLER BOARD	1	MULTI.B.	
32	R 0 1 E 1 4 2 3 9	FUSE 6.3A 250V	2	F1, F2	6.3A 250V
33	R 0 1 E 0 7 3 1 1	M-NET POWER BOARD	1	M-NET P.B.	
34	T 7 W M 0 1 3 2 3	POWER BOARD	1	P.B.	
35	R 0 1 A 2 3 3 7 1	HEAT SINK	1		Includes SCREWS
36	T 7 W 6 0 3 2 4 6	T.B./L1.L2.GR	1	TB1	3P (L1, L2, GR)
37	R 0 1 E 2 7 2 4 6	T.B./M1.M2.S	2	TB3, TB7	3P (M1, M2, S)
38	R 0 1 E 5 6 2 5 9	REACTOR	3	DCL	
39	R 0 1 M 1 6 2 0 2	THERMISTOR (HS)	1	TH8 (Heat Sink)	
40	T 7 W E 5 7 7 1 6	T.B./B1.B2	1	TB1B	2P (B1, B2)
41	R 0 1 E 2 0 2 3 9	FUSE 20 A 250 V	2	FUSE1, 2	20 A 250 V
42	R 0 1 3 0 L 2 4 1	FUSE HOLDER	2		
43	T 7 W E 3 9 3 4 6	NOISE FILTER	1	N.F.	
44	R 0 1 U 0 0 6 0 2	COMP FELT-U/ANB	1		

1-2. OUTDOOR UNIT FUNCTIONAL AND ELECTRICAL PARTS

MXZ-4C36NAHZ2-U1
 MXZ-5C42NAHZ2-U1
 MXZ-8C48NAHZ2-U1

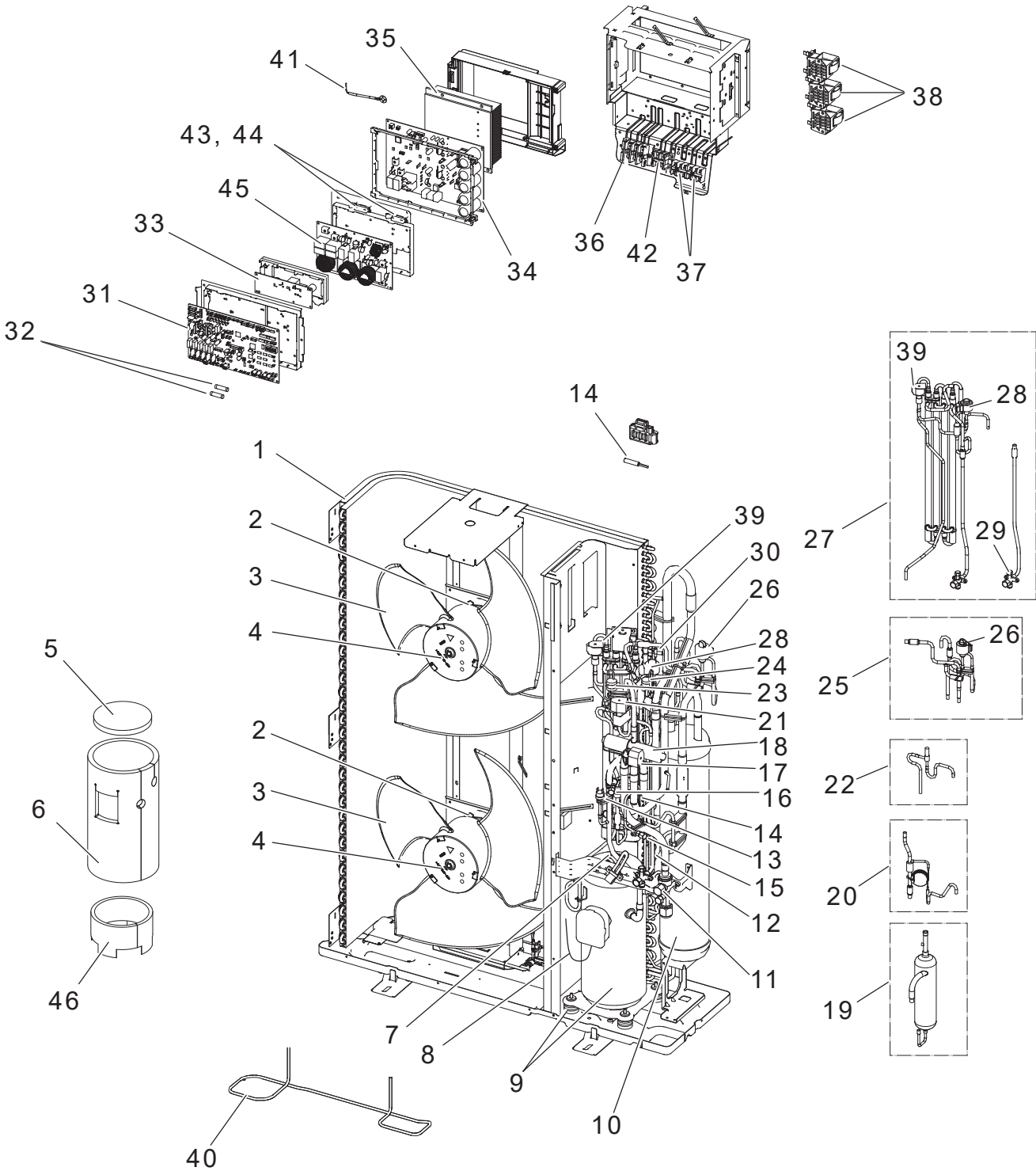

1. The part quantity below indicates the required number of pieces per unit.
2. The circled No. indicates that the part is not shown in the figure.

No.	Parts No.	Parts Name	MXZ-4C36NAHZ2-U1	MXZ-5C42NAHZ2-U1	MXZ-8C48NAHZ2-U1	Wiring Diagram Symbol	Remarks
1	R 01 R 65 408	HEAT EXCHANGER	1	1	1		
2	T 7W A 10 221	FAN MOTOR	2	2	2	MF1, MF2	
3	R 01 E 16 115	PROPELLER FAN/D550	2	2	2		
4	R 01 E 16 097	CAP NUT (MEC) M6	2	2	2		
5	R 01 A 57 602	COMP FELT (TOP)	1	1	1		
6	T 7W B 03 602	COMP FELT-B/ANB33FJ	1	1	1		
7	R 01 E 36 201	THERMISTOR (SHELL)	1	1	1	TH4 (Compressor)	
8	R 01 C 13 510	LEAD ASSY COMP	1	1	1		
9	T 97 4A0 012	COMPRESSOR	1	1	1	MC	ANB33FJSMT, Includes RUBBER MOUNT
10	R 01 E 81 440	ACCUMULATOR	1	1	1		
11	T 7W E 11 411	BALL VALVE & STRAINER	1	1	1		5/8
12	R 01 M 30 202	THERMISTOR	1	1	1	TH2 (HIC Pipe)	
13	T 7W E 15 208	H. P. SWITCH UL4.14MPA	1	1	1	63H	
14	R 01 M 31 202	THERMISTOR W	1	1	1	TH6 (Suction Pipe), TH7 (Ambient)	Combined Port
15	T 7W E 13 413	CHARGE PLUG/LB54	1	1	1		Lo
16	R 01 E 12 413	CHARGE PLUG/LB90	1	1	1		Hi
17	T 7W F 00 242	SOLENOID COIL (21S4)	1	1	1	21S4	Includes SCREW
18	R 01 E 40 403	4WAY VALVE	1	1	1	21S4	
19	R 01 E 16 490	OIL SEPARATOR	1	1	1		
20	R 01 E 02 426	CT ASSY	1	1	1		
21	T 7W E 91 242	SOLENOID COIL (SV)	1	1	1	SV1	Includes SCREW
22	T 7W E 11 428	SV1 ASSY	1	1	1	SV1	
23	R 01 E 14 208	H. P. SENSOR	1	1	1	63HS	
24	R 01 E 04 209	LOW PRESSURE SENSOR	1	1	1	63LS	
25	R 01 R 27 401	LEV ASSY-A	1	1	1	LEV-A	
26	R 01 HR1 242	COIL (LEV)/XAP-5P WH	1	1	1	LEV-A	
27	T 7W B 09 401	HIC & LEV-B ASSY	1	1	1	LEV-B	
28	R 01 H 58 242	COIL (LEV)/XAP-5P RED	1	1	1	LEV-B	
29	T 7W E 15 410	STOP VALVE ASSY-3/8F	1	1	1		3/8
30	R 01 H 87 202	THERMISTOR	1	1	1	TH3 (Outdoor Liquid Pipe)	
31	R 01 M 24 350	CONTROLLER BOARD	1	1	1	MULTI.B.	
32	R 01 E 14 239	FUSE 6.3A 250V	2	2	2	F1, F2	6.3A 250V
33	R 01 E 07 311	M-NET POWER BOARD	1	1	1	M-NET P.B.	
34	T 7W M 01 323	POWER BOARD	1	1	1	P.B.	
35	R 01 A 23 371	HEAT SINK	1	1	1		Includes SCREWS
36	T 7W 603 246	T.B./L1.L2.GR	1	1	1	TB1	3P (L1, L2, GR)
37	R 01 E 27 246	T.B./M1.M2.S	2	2	2	TB3, TB7	3P (M1, M2, S)
38	R 01 E 56 259	REACTOR	3	3	3	DCL	
39	T 7W E 72 242	SOLENOID COIL (SV)	1	1	1	SV2	Includes SCREW
40	T 7W B 03 300	BASE HEATER	1	1	1	BH, THP	
41	R 01 M 16 202	THERMISTOR (HS)	1	1	1	TH8 (Heat Sink)	
42	T 7W E 57 716	T.B./B1.B2	1	1	1	TB1B	2P (B1, B2)
43	R 01 E 20 239	FUSE 20 A 250 V	2	2	2	FUSE1, 2	20 A 250 V
44	R 01 30L 241	FUSE HOLDER	2	2	2		
45	T 7W E 39 346	NOISE FILTER	1	1	1	N.F.	
46	R 01 U 00 602	COMP FELT-U/ANB	1	1	1		

1-3. BRANCH BOX FUNCTIONAL PARTS

PAC-MKA32BC PAC-MKA52BC

PAC-MKA33BC PAC-MKA53BC

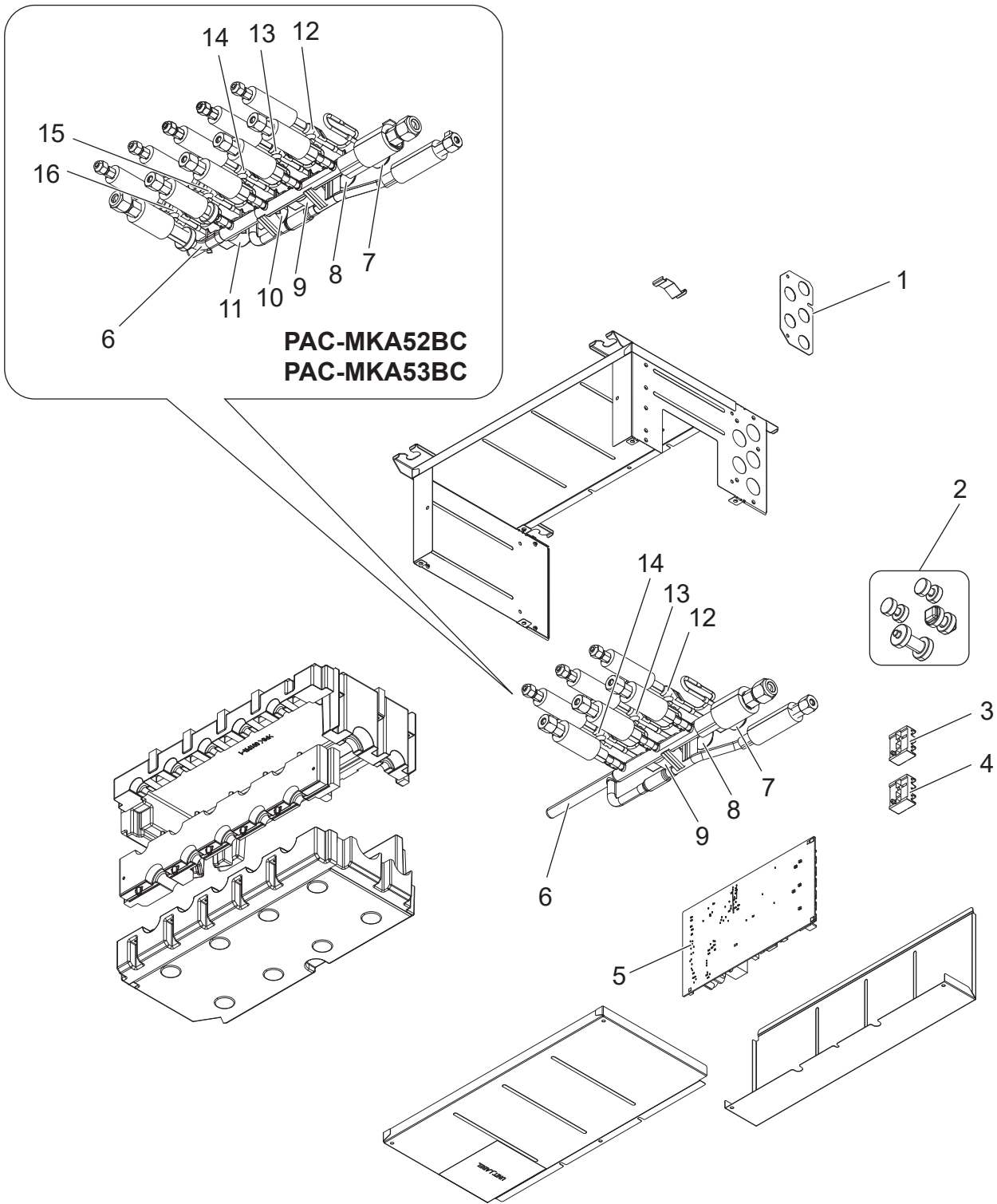

1. The part quantity below indicates the required number of pieces per unit.
2. The circled No. indicates that the part is not shown in the figure.

No.	Parts No.	Parts Name	PAC-MKA32BC	PAC-MKA52BC	PAC-MKA33BC	PAC-MKA53BC	Wiring Diagram Symbol	Remarks
1	T7W E06 617	CONDUIT PLATE	1	1	1	1		
2	T7W E04 124	BUSH SET	1		1			
3	T7W E60 716	T.B./M1.M2.S	1	1			TB5	3P (M1, M2, S)
3	T7W E77 716	T.B./M1.M2.S			1	1	TB5	3P (M1, M2, S)
4	T7W E59 716	T.B./L1.L2	1	1			TB2B	2P (L1, L2)
4	T7W E79 716	T.B./L1.L2			1	1	TB2B	2P (L1, L2)
5	T7W F23 310	CONTROLLER BOARD	1				B.C.	
5	T7W F24 310	CONTROLLER BOARD		1			B.C.	
5	T7W F37 310	CONTROLLER BOARD			1		B.C.	
5	T7W F36 310	CONTROLLER BOARD				1	B.C.	
6	T7W F07 401	LEV ASSY MKA32BC	1		1			Includes coils
6	T7W F08 401	LEV ASSY MKA52BC		1		1		Includes coils
7	T7W E73 242	COIL(LEV)/XAP-5P WH	1	1	1	1	LEV-A (WHITE)	
8	R01 H38 242	COIL(LEV)/XAP-5P RED	1	1	1	1	LEV-B (RED)	
9	T7W E80 242	COIL(LEV)/XAP-5P BLU	1	1	1	1	LEV-C (BLUE)	
10	T7W E76 242	COIL(LEV)/XAP-5P BLK		1		1	LEV-D (BLACK)	
11	T7W E77 242	COIL(LEV)/XAP-5P GRN		1		1	LEV-E (GREEN)	
12	T7W E66 202	THERMISTOR-A	1	1	1	1	TH-A (WHITE)	
13	T7W E67 202	THERMISTOR-B	1	1	1	1	TH-B (RED)	
14	T7W E68 202	THERMISTOR-C	1	1	1	1	TH-C (BLUE)	
15	T7W E69 202	THERMISTOR-D		1		1	TH-D (BLACK)	
16	T7W E70 202	THERMISTOR-E		1		1	TH-E (GREEN)	
17	T7W H18 392	LEAD WIRE SET	1	1	1	1		
18	R01 E14 239	FUSE 6.3 A 250 V	1	1			F1	6.3 A 250 V
19	R01 E21 239	FUSE 10 A 250 V	2	3			F2, F3, (F4)	10 A 250 V
20	R01 E09 660	PIPE COVER SET	1	1	1	1		STEM
21	R01 E08 660	PIPE COVER SET	1	1	1	1		BRANCH

2

OPTIONAL PARTS

2-1. FOR OUTDOOR UNIT

Parts name	Parts No.
DRAIN SOCKET*	PAC-SG61DS-E
AIR OUTLET GUIDE* ¹	PAC-SH96SG-E
DRAIN PAN*	PAC-SH97DP-E
2-BRANCH PIPE (Joint) (In case of using 2-branch boxes)* ²	MSDD-50AR-E (flare)
	MSDD-50BR-E (brazing)
BASE HEATER	PAC-SJ20BH-E

* It cannot be used with a base heater.

*¹ Need 2 pieces.

*² Select a joint according to the connection method.

2-2. FOR BRANCH BOX

Different-diameter joint

Part No.	Connected pipes diameter	Diameter A	Diameter B
	mm	mm	mm
MAC-A454JP-E	ø9.52 → ø12.7	ø9.52	ø12.7
MAC-A455JP-E	ø12.7 → ø9.52	ø12.7	ø9.52
MAC-A456JP-E	ø12.7 → ø15.88	ø12.7	ø15.88
PAC-493PI	ø6.35 → ø9.52	ø6.35	ø9.52
PAC-SG76RJ-E	ø9.52 → ø15.88	ø9.52	ø15.88
PAC-SG75RJ-E	ø15.88 → ø19.05	ø15.88	ø19.05

<Reference>

Conversion formula

1/4 in	ø6.35 mm
3/8 in	ø9.52 mm
1/2 in	ø12.7 mm
5/8 in	ø15.88 mm
3/4 in	ø19.05 mm

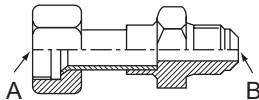

Parts name	Parts No.
Branch Box Outer Cover (for outdoor installation)	PAC-AK350CVR-E

MITSUBISHI ELECTRIC CORPORATION

HEAD OFFICE: TOKYO BUILDING, 2-7-3, MARUNOUCHI, CHIYODA-KU, TOKYO 100-8310, JAPAN