

MANUFACTURED FOR:
MITSUBISHI ELECTRIC US, INC.

Air Conditioners

PAA-A18, 24, 30, 36, 42AA1/BA1/CA1

SERVICE PARTS MANUAL

Table of Contents

1. EXTERNAL PARTS	3
2. HEX ASSEMBLY PARTS	5
3. CONTROL BOX PARTS	7

1. EXTERNAL PARTS

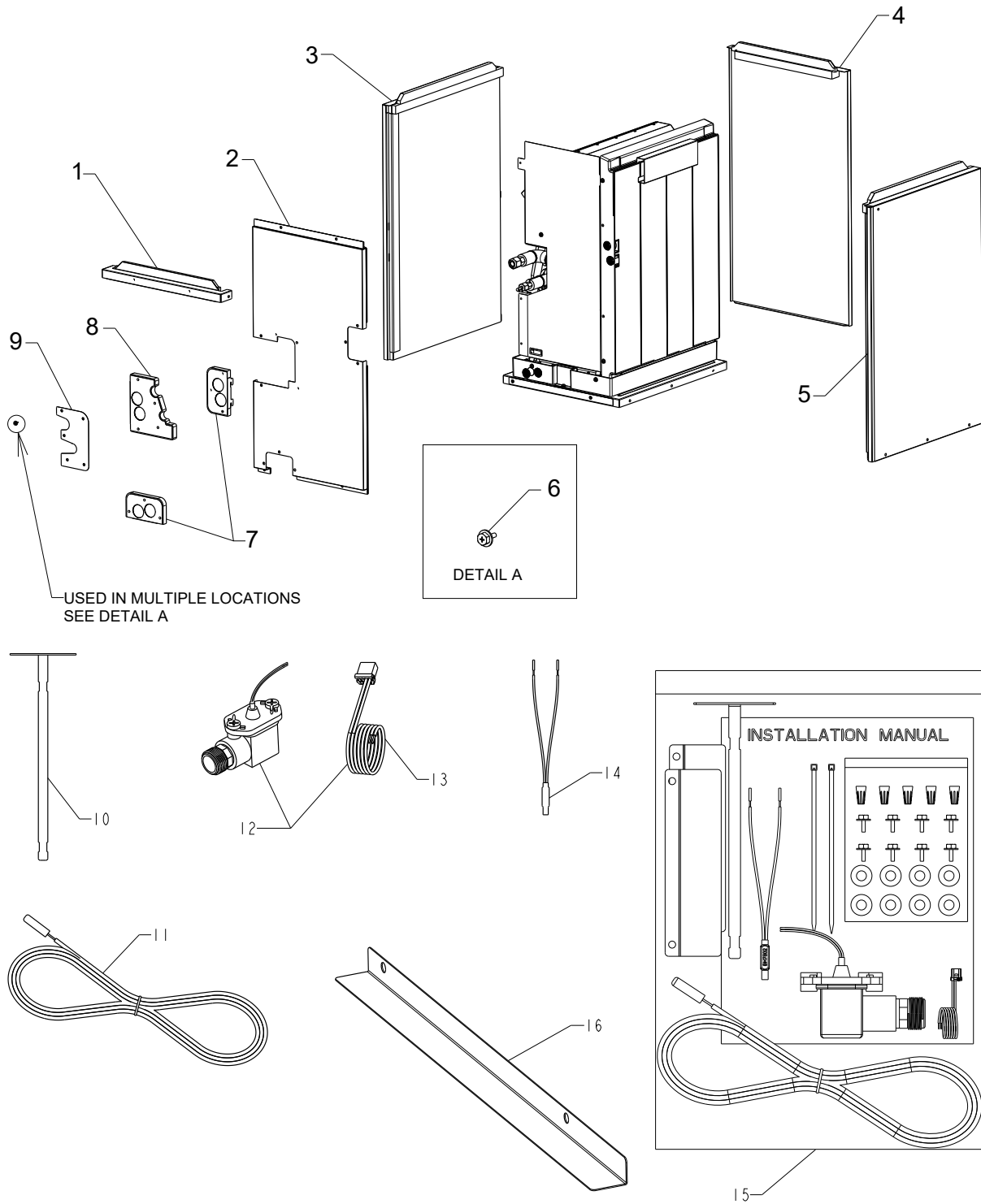

PAA-A18, 24, 30, 36, 42AA1/BA1/CA1

No.	Service Part No.	Part Name	Symbol in Wiring Diagram	Quantity per unit										Remarks		
				PAA-A												
				18AA1	18BA1	24AA1	24BA1	30AA1	30BA1	36BA1	36CA1	42BA1	42CA1			
1	U41 011 668	TOP COVER ASSY 14.5		1		1		1								
	U41 012 668	TOP COVER ASSY 17.5			1		1		1	1			1			
	U41 013 668	TOP COVER ASSY 21										1			1	
2	U41 006 639	FRONT PANEL ASSY 14.5M		1		1		1								NOTE: The nameplate must be removed from the original front panel and placed on the new front panel. Document the model and serial number before removing nameplate and contact distributor for a replacement nameplate if necessary.
	U41 007 639	FRONT PANEL ASSY 17.5M			1		1		1							
	U41 008 639	FRONT PANEL ASSY 17.5L								1			1			
	U41 009 639	FRONT PANEL ASSY 21L									1			1		
3	U41 023 638	LEFT PANEL ASSY, MED		1	1	1	1	1	1							
	U41 024 638	LEFT PANEL ASSY, LARGE								1	1	1	1	1		
4	U41 019 638	BACK PANEL ASSY 145M		1		1		1								
	U41 020 638	BACK PANEL ASSY 175M			1		1		1							
	U41 021 638	BACK PANEL ASSY 175L								1			1			
	U41 022 638	BACK PANEL ASSY 21L									1			1		
5	U41 025 638	RIGHT PANEL ASSY, MED		1	1	1	1	1	1							
	U41 018 638	RIGHT PANEL ASSY, LARGE								1	1	1	1	1		
6	U41 008 087	SCREW H 5X10 KNURLED		30	30	30	30	30	30	30	30	30	30	30	30	Pack of 10
7	U41 013 635	PANEL PIPE ASSY		2	2	2	2	2	2	2	2	2	2	2	2	
8	U41 011 635	PANEL PIPE ASSY		1	1	1	1	1	1	1	1	1	1	1	1	
9	U41 012 635	PANEL PIPE ASSY		1	1	1	1	1	1	1	1	1	1	1	1	
10	U71 001 086	SENSOR BRACKET		1	1	1	1	1	1	1	1	1	1	1	1	Also included in Accessory Bag, Item 15
11	U71 002 200	THERMISTOR 8MM	TH1	1	1	1	1	1	1	1	1	1	1	1	1	Also included in Accessory Bag, Item 15
12	U41 003 541	FLOAT SWITCH + LEAD WIRE ASSY CN4F	CN4F	1	1	1	1	1	1	1	1	1	1	1	1	Includes Lead Wire CN4F Also included in Accessory Bag, Item 15
13	U41 015 392	LEAD WIRE ASSY CN4F	CN4F	1	1	1	1	1	1	1	1	1	1	1	1	This part is included in U41003541, Float Switch + LEAD WIRE service part kit. Also included in Accessory Bag, Item 15
14	U41 010 200	THERMOSTAT (NAT)	TB-B	1	1	1	1	1	1	1	1	1	1	1	1	Also included in Accessory Bag, Item 15
15	U41 009 818	ACCESSORY BAG, PAA		1	1	1	1	1	1	1	1	1	1	1	1	
16	U41 004 130	L BRACKET 14.5		1		1		1								
	U41 005 130	L BRACKET 17.5			1		1		1	1			1			
	U41 006 130	L BRACKET 21										1			1	

2. HEX ASSEMBLY PARTS

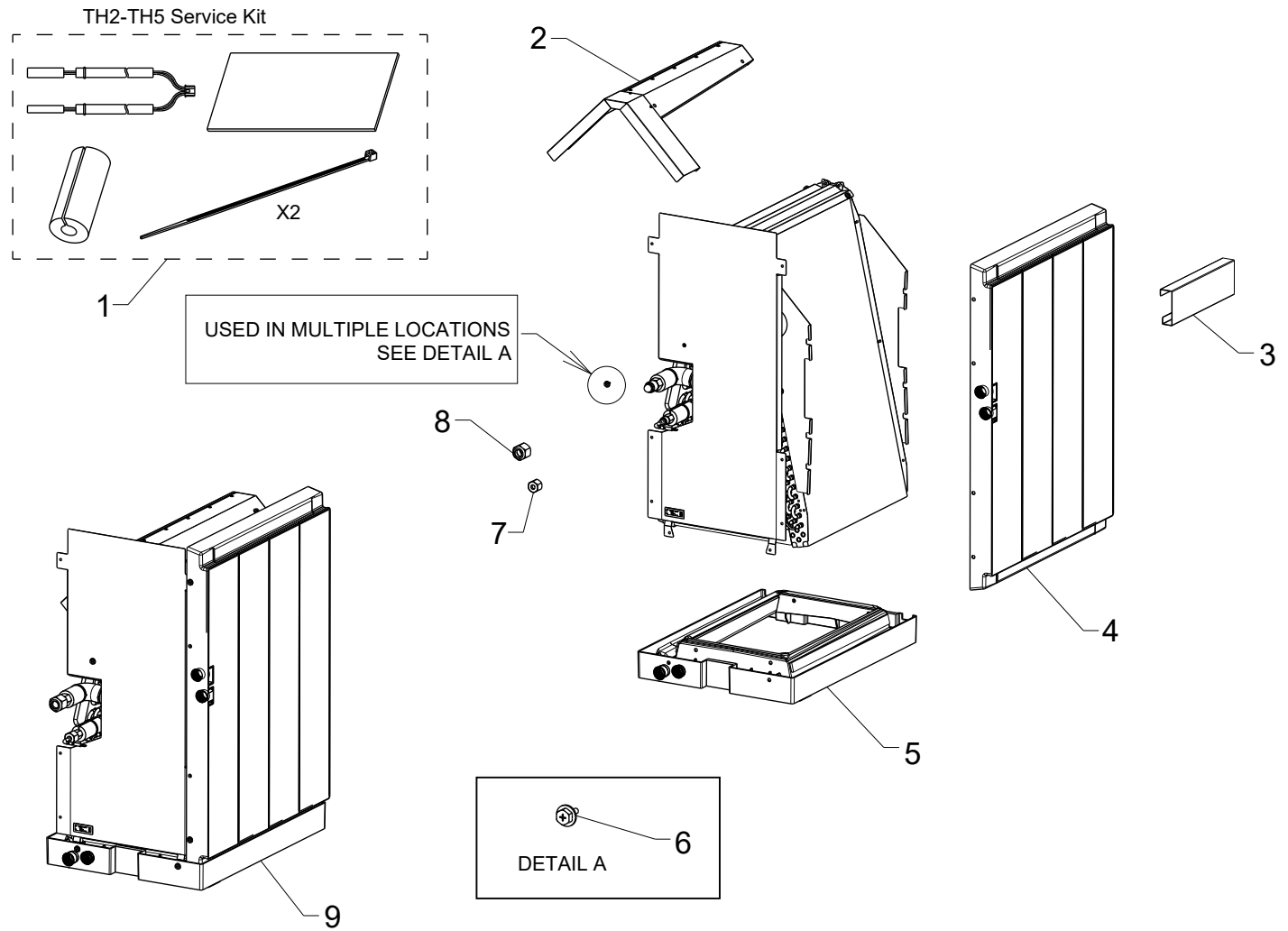

PAA-A18, 24, 30, 36, 42AA1/BA1/CA1

No.	Service Part No.	Part Name	Symbol in Wiring Diagram	Quantity per unit										Remarks		
				PAA-A												
				18AA1	18BA1	24AA1	24BA1	30AA1	30BA1	36BA1	36CA1	42BA1	42CA1			
1	U41 009 200	TH2-TH5 SERVICE KIT, PAA		1	1	1	1	1	1	1	1	1	1	1	1	Includes TH2-TH5 Wire Assy, 2 different Insulator Pipe Covers, and 2 ties ALL OF WHICH ARE SPECIFIED FOR USE IN THE PAA HIGH TEMP AREAS
2	U41 007 668	TOP PLATE DR ASSY, S		1	1											
	U41 008 668	TOP PLATE DR ASSY, L				1	1	1	1							
	U41 009 668	TOP PLATE DR ASSY, L-B								1			1			
	U41 010 668	TOP PLATE DR ASSY, L-C										1		1		
3	U41 019 529	SIDE PAN BRACKET		1	1	1	1	1	1	1	1	1	1	1	1	
5	U41 014 529	DRAIN PAN ASSY LOWER 14.5		1		1		1								
	U41 015 529	DRAIN PAN ASSY LOWER 17.5			1		1		1	1			1			
	U41 016 529	DRAIN PAN ASSY LOWER 21										1		1		
4	U41 017 529	DRAIN PAN ASSY SIDE, S		1	1	1	1	1	1							
	U41 018 529	DRAIN PAN ASSY SIDE, L									1	1	1	1		
6	U41 010 087	SCREW WFT 5X12		12	12	14	14	14	14	18	18	18	18	18	18	Pack of 10 Also used in the Control Box
7	U41 002 122	NUT FLARE 3/8				1	1	1	1	1	1	1	1	1	1	
	U41 004 122	NUT FLARE 1/4		1	1											
8	U41 003 122	NUT FLARE 1/2F		1	1											
	U41 001 122	NUT FLARE 5/8				1	1	1	1	1	1	1	1	1	1	
9	U41 043 480	HEX ASSY 14.5S PAA		1												Includes all parts on this page (TH2-TH5 wire assembly is pre-installed)
	U41 044 480	HEX ASSY 17.5S PAA			1											Includes all parts on this page (TH2-TH5 wire assembly is pre-installed)
	U41 039 480	HEX ASSY 14.5M PAA				1		1								Includes all parts on this page (TH2-TH5 wire assembly is pre-installed)
	U41 040 480	HEX ASSY 17.5M PAA					1		1							Includes all parts on this page (TH2-TH5 wire assembly is pre-installed)
	U41 041 480	HEX ASSY 17.5L PAA									1			1		Includes all parts on this page (TH2-TH5 wire assembly is pre-installed)
	U41 042 480	HEX ASSY 21L PAA											1		1	Includes all parts on this page (TH2-TH5 wire assembly is pre-installed)

3. CONTROL BOX PARTS

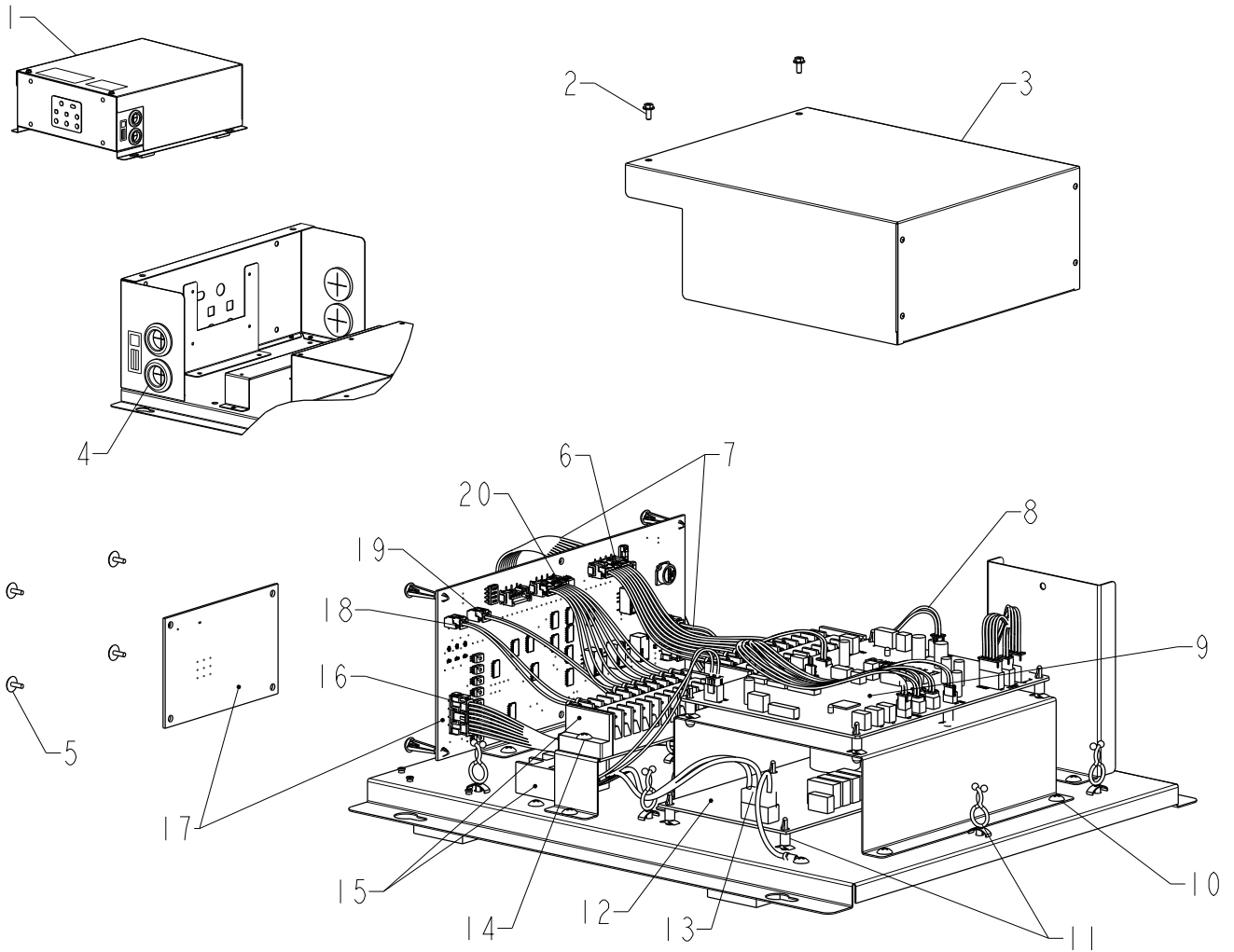

PAA-A18, 24, 30, 36, 42AA1/BA1/CA1

No.	Service Part No.	Part Name	Symbol in Wiring Diagram	Quantity per unit										Remarks		
				PAA-A												
				18AA1	18BA1	24AA1	24BA1	30AA1	30BA1	36BA1	36CA1	42BA1	42CA1			
1	U41 005 812	Control Box Assy 18		1	1											
	U41 006 812	Control Box Assy 24				1	1									
	U41 007 812	Control Box Assy 30						1	1							
	U41 008 812	Control Box Assy 36									1	1				
	U41 009 812	Control Box Assy 42											1	1		
2	U41 010 087	SCREW WFT 5X12		2	2	2	2	2	2	2	2	2	2	2	2	Pack of 10 Also used in the HEX assemblies.
3	U41 019 812	CONTROL BOX COVER		1	1	1	1	1	1	1	1	1	1	1	1	
4	U41 003 104	BUSHING		4	4	4	4	4	4	4	4	4	4	4	4	Pack of 2
5	INFO ONLY	SCREW M4 x 8		4	4	4	4	4	4	4	4	4	4	4	4	FIELD SUPPLIED
6	U41 019 392	LEAD WIRE ASSY CNH04	CNH04	1	1	1	1	1	1	1	1	1	1	1	1	
7	U41 022 392	LEAD WIRE ASSY CNH07	CNH07	1	1	1	1	1	1	1	1	1	1	1	1	
8	U41 023 392	LEAD WIRE ASSY CN22	CN22	1	1	1	1	1	1	1	1	1	1	1	1	
9	U41 012 280	PCBA IDU CTL BRD		1	1	1	1	1	1	1	1	1	1	1	1	
10	INFO ONLY	SCREW M4 x 10		12	12	12	12	12	12	12	12	12	12	12	12	FIELD SUPPLIED
11	U41 001 145	CLIPS & SUPPORTS		10 & 13	10 & 13	10 & 13	10 & 13	10 & 13	10 & 13	10 & 13	10 & 13	10 & 13	10 & 13	10 & 13	10 & 13	Pack of 5 each: clips & supports.
12	U41 005 280	PCA INDOOR POWER		1	1	1	1	1	1	1	1	1	1	1	1	
13	U41 024 392	LEAD WIRE ASSY POWER	CND	1	1	1	1	1	1	1	1	1	1	1	1	
14	INFO ONLY	SCREW M4 X20		5	5	5	5	5	5	5	5	5	5	5	5	FIELD SUPPLIED
15	U41 006 246	TERMINAL BLOCK, BED, LABEL KIT	TB-A TB-B TB-C	1	1	1	1	1	1	1	1	1	1	1	1	Includes qty 1 terminal bed, qty 2 Terminal Blocks, qty 1 label
16	U41 016 392	LEAD WIRE ASSY CNH01	CNH01	1	1	1	1	1	1	1	1	1	1	1	1	
17	U41 001 225	PAA RELAY AND UI BD ASSEMBLIES		1	1	1	1	1	1	1	1	1	1	1	1	
18	U41 020 392	LEAD WIRE ASSY CNH05	CNH05	1	1	1	1	1	1	1	1	1	1	1	1	
19	U41 021 392	LEAD WIRE ASSY CNH06	CNH06	1	1	1	1	1	1	1	1	1	1	1	1	
20	U41 018 392	LEAD WIRE ASSY CNH03	CNH03	1	1	1	1	1	1	1	1	1	1	1	1	
-	U41 015 392	LEAD WIRE ASSY CN4F	CN4F	1	1	1	1	1	1	1	1	1	1	1	1	This part is shown in the External Service Parts section. It is available individually, as part of the Float Switch + LEAD WIRE kit, and as part of the Accessory Bag.

Optional Items

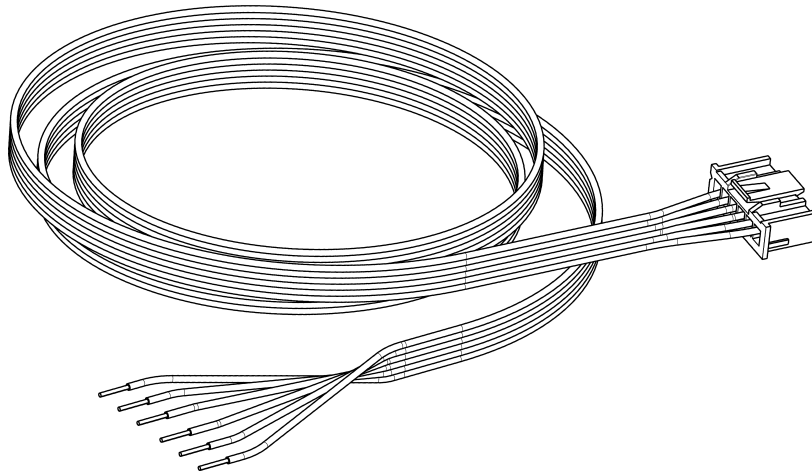

OPTIONAL ITEMS				
Part Name	Part Number	Remarks	Symbol in Wiring Diagram	Models
LEAD WIRE ASSY CNH02	U41 017 392	Optional for connection to Thermostat Interface 2, PAC-US445CN*. (This part is included with PAC-US445CN*)	CNH02	Optional use with all PAA Models

This product is designed and intended for use in the residential and commercial environment.

Please be sure to put the contact address/telephone number on this manual before handing it to the customer.



Manufactured for:
MITSUBISHI ELECTRIC US, INC.

www.mitsubishielectric-usa.com

Toll Free: 800-433-4822