



SPLIT-TYPE, HEAT PUMP AIR CONDITIONERS
SPLIT-TYPE, AIR CONDITIONERS

October 2023

No. OCB501
REVISED EDITION-A

PARTS CATALOG

Series PCA Ceiling Suspended R410A

Indoor unit
[Model names]

[Service Ref.]

PCA-A24KA4

PCA-A24KA4.TH

PCA-A30KA4

PCA-A30KA4.TH

PCA-A36KA4

PCA-A36KA4.TH

PCA-A42KA4

PCA-A42KA5.TH

Revision:
• Changed the reference No.
of sirocco fans in REVISED
EDITION A.

OCB501 is void.

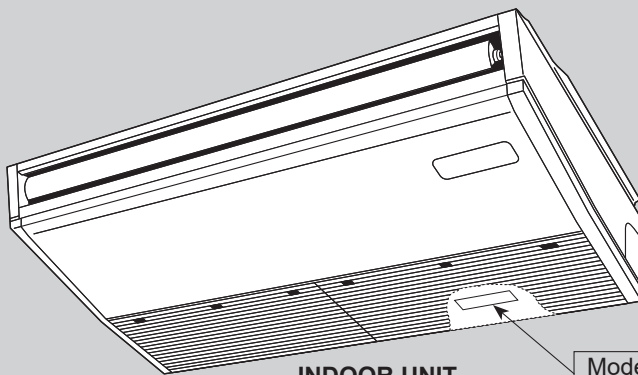

INDOOR UNIT

Model name
indication

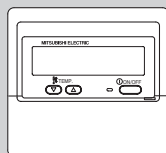

WIRED REMOTE
CONTROLLER
(Option)

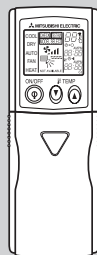

IR WIRELESS REMOTE
CONTROLLER (Option)

CONTENTS

1. SERVICE PARTS LIST 2

SERVICE MANUAL (OCH501)



STRUCTURAL AND FUNCTIONAL PARTS (1)

PCA-A24KA4.TH

PCA-A30KA4.TH

PCA-A36KA4.TH

PCA-A42KA5.TH

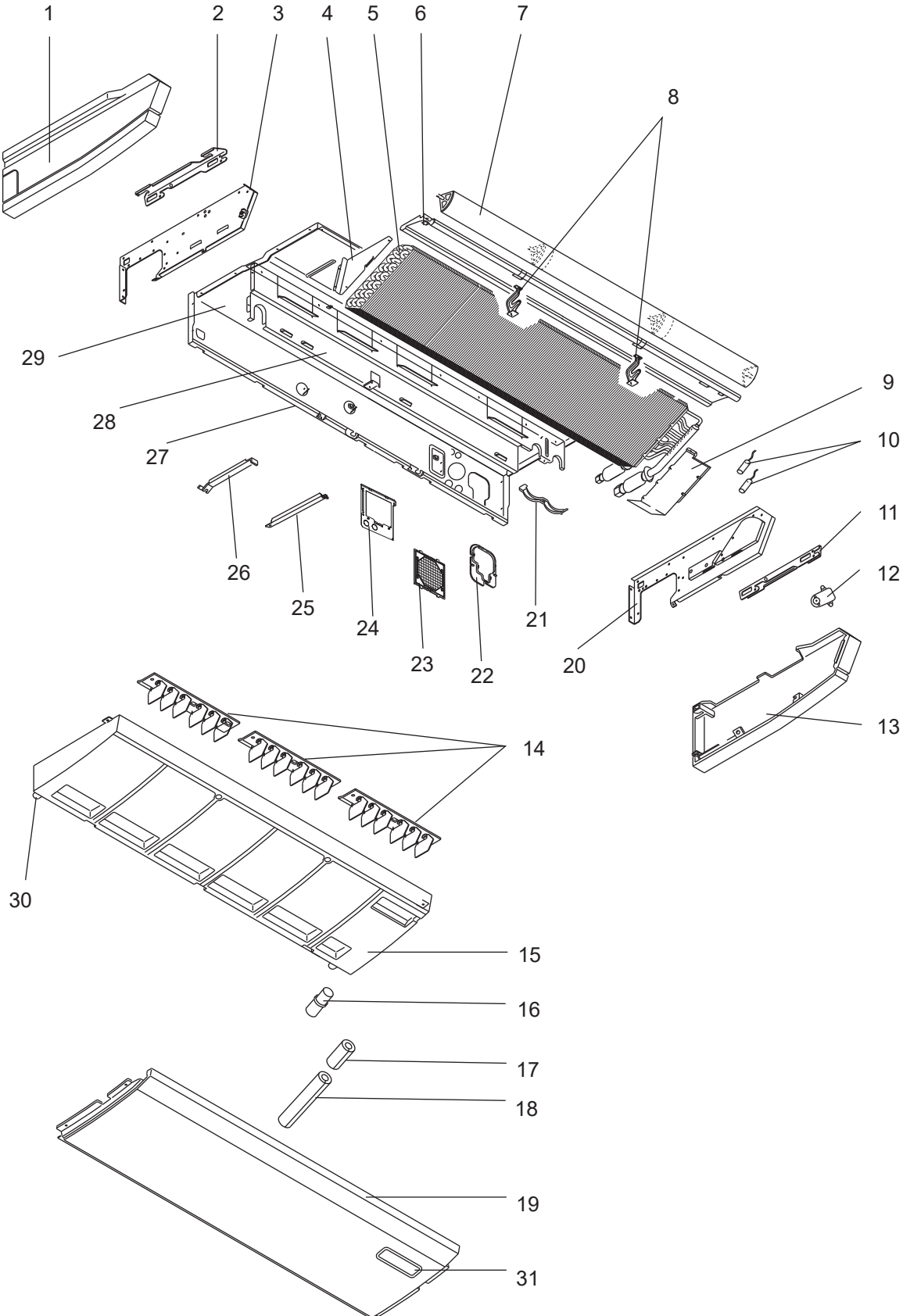

1. The part quantity below indicates the required number of pieces per unit.
2. The circled No. indicates that the part is not shown in the figure.

No.	Part No.	Part Name	PCA-A24KA4.TH	PCA-A30KA4.TH	PCA-A36KA4.TH	PCA-A42KA5.TH	Wiring Diagram Symbol	Remarks [Drawing No.]
1	E17 648 086	SIDE PANEL-L	1	1	1	1		
2	E17 648 809	LEG-L	1	1	1	1		
3	E17 664 252	SIDE PLATE-L	1	1	1	1		
4	E17 648 648	COIL SUPPORT-H	1	1				
4	E17 649 648	COIL SUPPORT-H			1			
4	E17 651 648	COIL SUPPORT-H				1		
5	E17 664 620	HEAT EXCHANGER	1	1				
5	E17 666 620	HEAT EXCHANGER			1			
5	E17 782 620	HEAT EXCHANGER				1		
6	E17 664 000	FRONT PANEL	1	1				
6	E17 666 000	FRONT PANEL			1	1		
7	E17 648 037	AUTO VANE	1	1				
7	E17 649 037	AUTO VANE			1	1		
8	E17 648 043	VANE SUPPORT	2	2	2	2		
9	E17 650 648	COIL SUPPORT	1	1	1	1		
10	E17 696 307	THERMISTOR (PIPE)	1	1	1	1	TH2	
11	E17 648 808	LEG-R	1	1	1	1		
12	E17 648 303	VANE MOTOR ASSY	1	1	1	1	MV	
13	E17 648 085	SIDE PANEL-R	1	1	1	1		
14	E17 648 042	GUIDE VANE	3	3				
14	E17 649 042	GUIDE VANE			3	3		
15	E17 664 700	DRAIN PAN	1	1				
15	E17 666 700	DRAIN PAN			1	1		
16	E17 648 704	JOINT SOCKET	1	1	1	1		
17	E17 648 706	DRAIN SOCKET COVER	1	1	1	1		
18	E17 648 703	DRAIN HOSE COVER	1	1	1	1		
19	E17 648 717	UNDER PANEL	1	1				
19	E17 649 717	UNDER PANEL			1	1		
20	E17 664 251	SIDE PLATE-R	1	1	1	1		
21	E17 648 708	PIPE BAND	1	1	1	1		
22	E17 648 903	PIPE HOLE COVER	1	1	1	1		
23	E17 664 100	AIR FILTER	1	1	1	1		
24	E17 664 102	FILTER GUIDE	1	1	1	1		
25	-	BEAM	1	1	1	1		[BH02G431G12]
26	-	BEAM	1	1	1	1		[RG00D642G06]
27	E17 664 522	REAR PANEL	1	1				
27	E17 666 522	REAR PANEL			1	1		
28	-	FAN PLATE	1	1				[BH00B360G24]
28	-	FAN PLATE			1	1		[BH00B360G25]
29	E17 648 290	BASE	1	1				
29	E17 649 290	BASE			1	1		
30	E17 648 524	DRAIN PLUG	1	1	1	1		
31	-	CI PLATE	1	1	1	1		[BK00J592G01]

STRUCTURAL AND FUNCTIONAL PARTS (2)

PCA-A24KA4.TH

PCA-A30KA4.TH

PCA-A36KA4.TH

PCA-A42KA5.TH

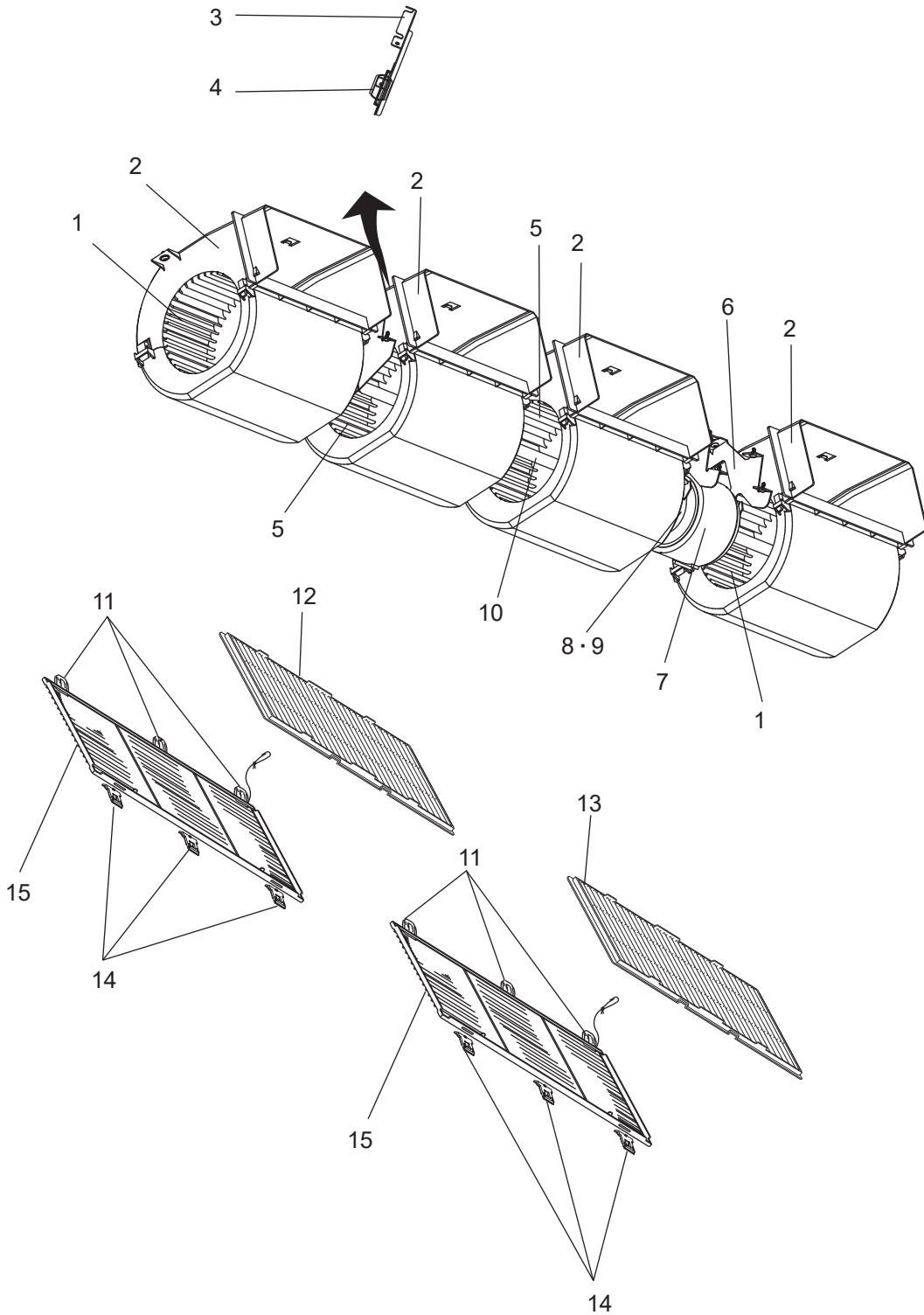

1. The part quantity below indicates the required number of pieces per unit.
2. The circled No. indicates that the part is not shown in the figure.

No.	Part No.	Part Name	PCA-A24KA4.TH	PCA-A30KA4.TH	PCA-A36KA4.TH	PCA-A42KA5.TH	Wiring Diagram Symbol	Remarks [Drawing No.]
1	E17 648 500	SIROCCO FAN	3	3	2	2		
2	E17 648 237	FAN CASING	3	3	4	4		TOP+UNDER
3	E17 648 512	BEARING SUPPORT	1	1	1	1		
4	E17 648 504	BEARING	1	1	1	1		
5	E17 649 500	SIROCCO FAN			2	2		
6	E17 648 334	MOTOR LEG	1	1	1	1		
7	E17 648 300	INDOOR FAN MOTOR	1	1			MF	
7	E17 649 300	INDOOR FAN MOTOR			1	1	MF	
8	E17 648 333	PIECE (MOTOR) R.L	1	1	1	1		
9	E17 648 518	FAN JOINT ASSY	1	1	1	1		
10	E17 648 499	SHAFT FAN	1	1				
10	E17 649 499	SHAFT FAN			1	1		
11	E17 648 143	GRILLE HINGE	5	5	6	6		
12	E17 648 100	AIR FILTER	1	1				Small
13	E17 649 100	AIR FILTER	1	1	2	2		Large
14	E17 648 142	GRILLE CATCH	5	5	6	6		
15	E17 648 010	GRILLE (SMALL)	1	1				
15	E17 649 010	GRILLE (LARGE)	1	1	2	2		

ELECTRICAL PARTS

PCA-A24KA4.TH

PCA-A30KA4.TH

PCA-A36KA4.TH

PCA-A42KA5.TH

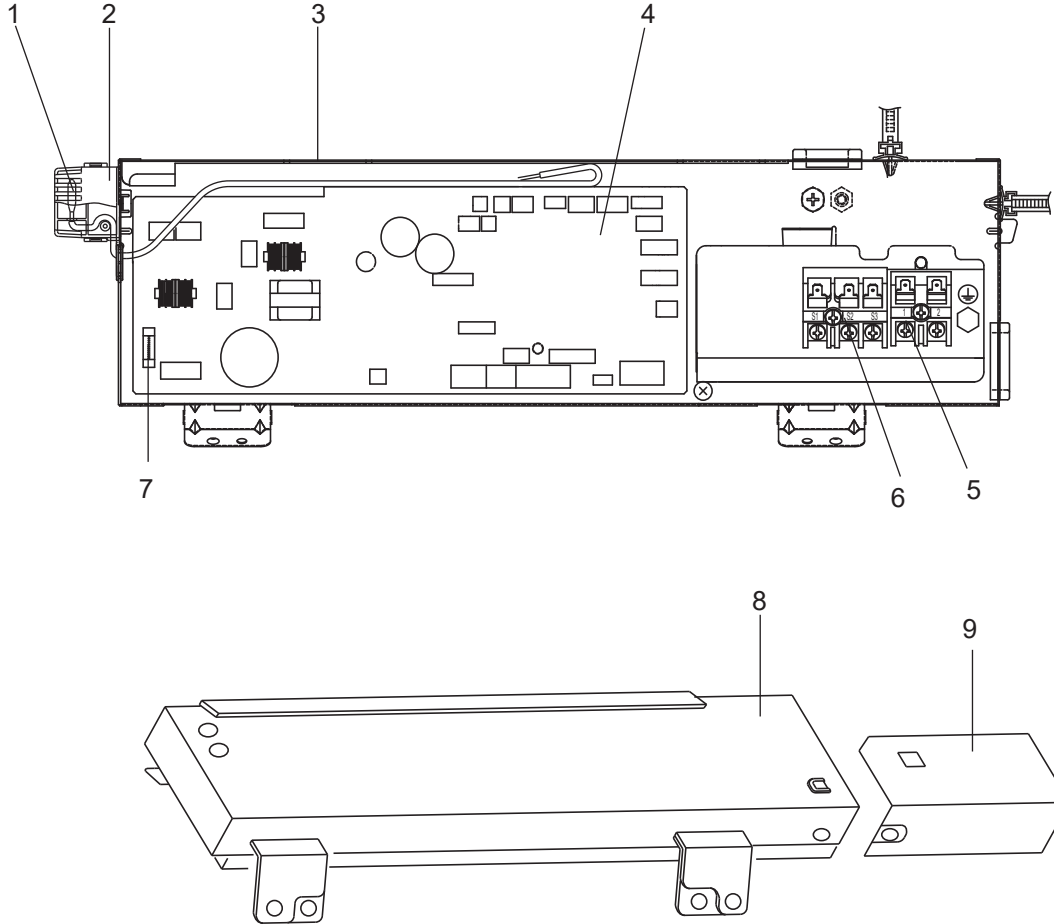

1. The part quantity below indicates the required number of pieces per unit.
 2. The circled No. indicates that the part is not shown in the figure.

No.	Part No.	Part Name	PCA-A24KA4.TH	PCA-A30KA4.TH	PCA-A36KA4.TH	PCA-A42KA5.TH	Wiring Diagram Symbol	Remarks [Drawing No.]
1	E17 518 308	THERMISTOR (ROOM)	1	1	1	1	TH1	
2	-	SENSOR COVER	1	1	1	1		[RG25V835G03]
3	-	ELECTRICAL BOX	1	1	1	1		[BH00R345G08]
4	E17 664 447	CONTROLLER BOARD	1	1	1	1	I.B.	
5	E17 516 375	TERMINAL BLOCK	1	1	1	1	TB5	2P (1, 2)
6	E17 162 375	TERMINAL BLOCK	1	1	1	1	TB4	3P (S1, S2, S3)
7	E17 648 382	FUSE	1	1	1	1	FUSE	6.3A 250VAC
8	-	ELECTRICAL BOX COVER	1	1	1			[BH00R348G11]
8	-	ELECTRICAL BOX COVER				1		[BH00R348G22]
9	-	ELECTRICAL BOX COVER	1	1	1	1		[RG02V755G03]
⑩	E12 A45 385	VARISTOR	1	1	1	1	ZNR01,02	

Mr. SLIM

mitsubishi electric corporation

HEAD OFFICE: TOKYO BUILDING, 2-7-3, MARUNOUCHI, CHIYODA-KU, TOKYO 100-8310, JAPAN
