

SUBMITTAL DATA: MSZ-FH18NA2 & MUZ-FH18NAH2
18,000 BTU/H WALL-MOUNTED HEAT PUMP SYSTEM

Job Name:	Location:	Date:
Purchaser:	Engineer:	
Submitted to:	For <input type="checkbox"/> Reference <input type="checkbox"/> Approval <input type="checkbox"/> Construction	
System Designation:	Schedule No.:	



GENERAL FEATURES

- Highly energy-efficient system that features 100% heating capacity at -15°C (5°F), 82% at -20°C (-4°F), and 62% at -25°C (-13°F)
- Updated sleek, compact indoor unit design
- Includes Standard, Platinum Deodorizing, and Anti-allergy Enzyme filters for a complete air purified system
- "Powerful Mode" function permits system to temporarily run at a lower/higher temperature with an increased fan speed, which quickly brings the room to the optimum comfort level
- 3D i-see Sensor detects where you are in the room and analyzes the difference between your body temperature and that of the air around you
- Hand-held Wireless Remote Controller
- Limited warranty: five years parts and seven years compressor
- COP at 5°F / 2.06

ACCESSORIES

- Replacement Platinum Deodorizing Filter (MAC-3000FT-E)
- Replacement Anti-allergy Enzyme Filter (MAC-2330FT-E)
- External heater connector cable (MAC-1710RA-U)
(Field supply 12VDC 8 mAmp relay used with Ext. Htg. connector)
- Windscreens (ME-FR-24)

Controller Options

- Wireless Wall-mounted Remote Controller Kit (MHK1)*
 - Portable Central Controller (MCCH1)*
 - Outdoor Air Sensor (MOS1)*
 - Wired Wall-mounted Controller (PAR-31MAA requires MAC-333IF)*
 - Simple MA Remote Controller (PAC-YT53CRAU requires MAC-333IF)*
- *See Submittal for information on each option.
- System Control Interface (MAC-333IF)

Note: Mitsubishi Electric (MESCA) supports the use of only MESCA supplied and approved Snow Guard / Wind Deflectors / Windscreens and accessories for proper functioning of the unit(s). Use of non-MESCA supported Snow Guard / Wind Deflectors / Windscreens and accessories will affect warranty coverage.

DIMENSIONS: MSZ-FH18NA2 & MUZ-FH18NAH2

MSZ-FH18NA

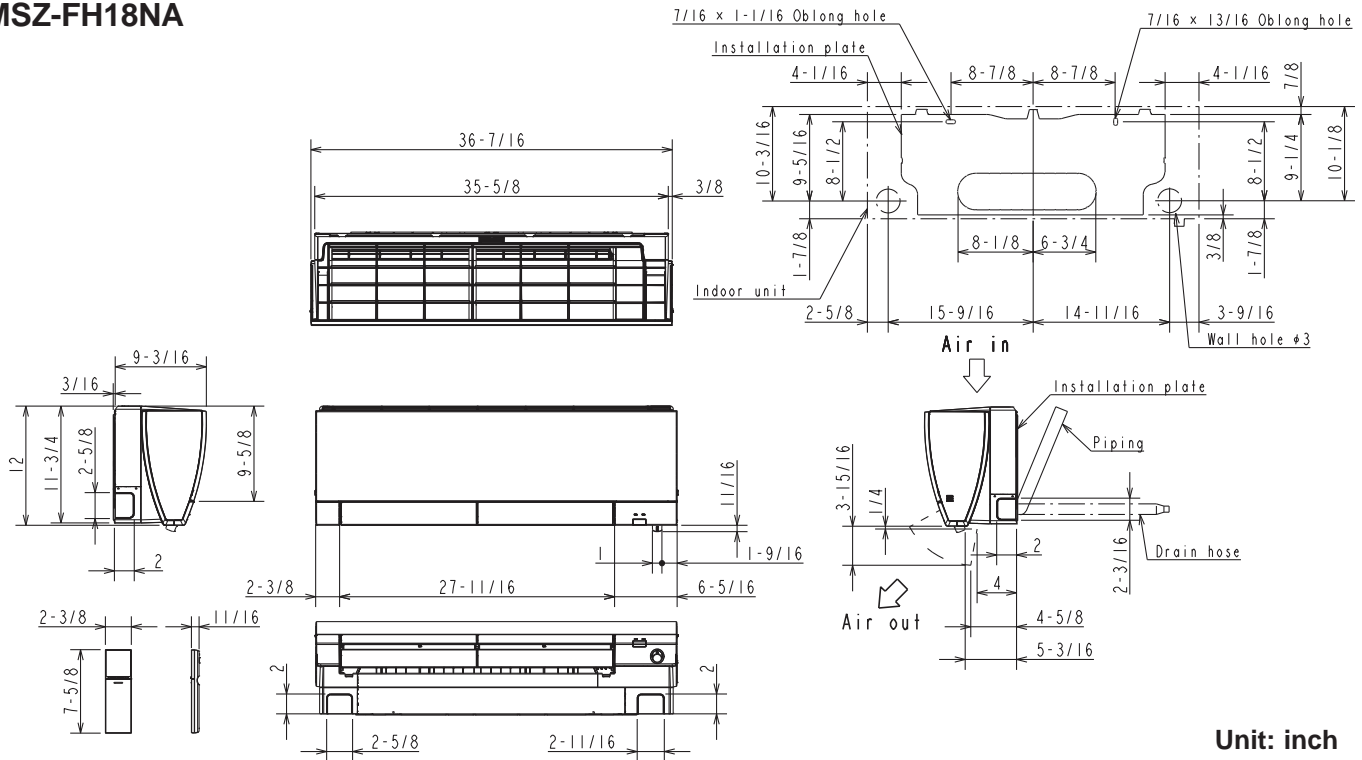

Unit: inch

MUZ-FH18NAH

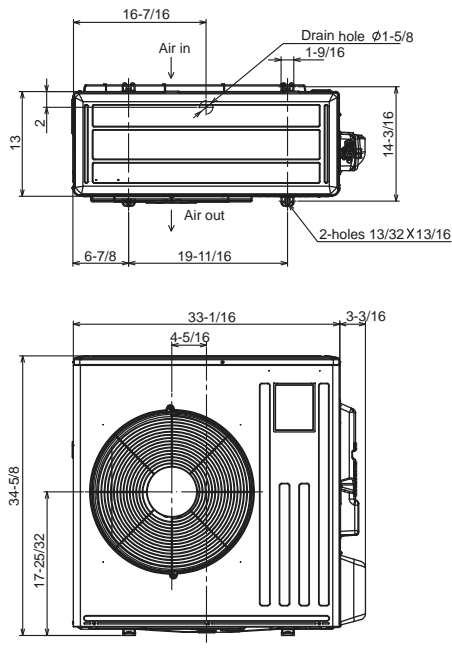

REQUIRED SPACE

*1 20 in. (500 mm) or more when front and sides of the unit are clear

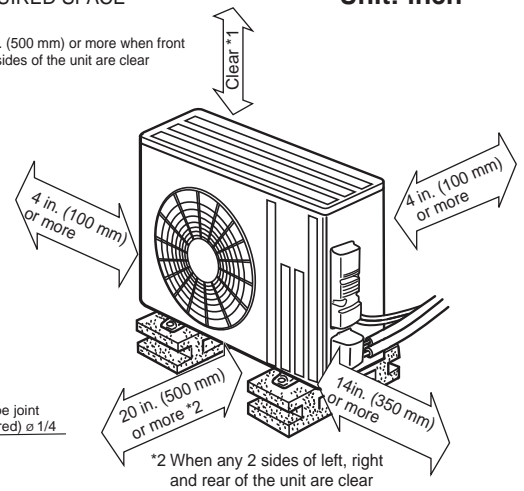

Unit: inch



Should this document be altered or changed without MESCA's permission, it becomes null and void. MESCA assumes no responsibility for any consequences in such cases.