

SUBMITTAL DATA: MXZ-4C36NAHZ2-U1

MULTI-INDOOR INVERTER HEAT-PUMP SYSTEM

Job Name:	Location:	Date:
Purchaser:	Engineer:	
Submitted to:	For <input type="checkbox"/> Reference <input type="checkbox"/> Approval <input type="checkbox"/> Construction	
System Designation:	Schedule No.:	

GENERAL FEATURES

- Quiet operation
- Built-in base pan heater to prevent ice in drain pan

ACCESSORIES

- Three-port Branch Box (PAC-MKA32BC)
- Five-port Branch Box (PAC-MKA52BC)
- Distribution Pipe for Flare Connection (MSDD-50AR; necessary for installing two branch boxes)
- Distribution Pipe for Brazed Connection (MSDD-50BR; necessary for installing two branch boxes)
- 3/8" x 1/2" Port Adapter (MAC-A454JP)
- 1/2" x 3/8" Port Adapter (MAC-A455JP)
- 1/2" x 5/8" Port Adapter (MAC-A456JP)
- 1/4" x 3/8" Port Adapter (PAC-493PI)
- 3/8" x 5/8" Port Adapter (PAC-SG76RJ)
- Windscreens (*1)



Note: Mitsubishi Electric (MESCA) supports the use of only MESCA supplied and approved Snow Guard / Wind Deflectors / Windscreens and accessories for proper functioning of the unit(s). Use of non-MESCA supported Snow Guard / Wind Deflectors / Windscreens and accessories will affect warranty coverage.

Specifications			Model Name
Unit Type			MXZ-4C36NAHZ
Cooling* Non-ducted / Ducted	Rated Capacity	Btu/h	36,000 / 36,000
	Rated Total Input	W	2,570 / 2,880
Heating at 47°F* (8.3°C*) Non-ducted / Ducted	Rated Capacity	Btu/h	45,000 / 45,000
	Rated Total Input	W	3,340 / 3,560
Heating at 17°F* (-8.3°C*) Non-ducted / Ducted	Maximum Capacity	Btu/h	45,000 / 45,000
Heating at 5°F* (-15°C*)	Maximum Capacity	Btu/h	45,000
Electrical Requirements	Power Supply	Voltage, Phase, Hertz	208 / 230V, 1-Phase, 60 Hz
	Max. Breaker Size / Max. Fuse Size	A	45 / 50
	MCA	A	42
Voltage	Indoor - Outdoor S1-S2	V	AC 208 / 230
	Indoor - Outdoor S2-S3	V	+12VDC to +24VDC
Compressor			Hermetic
Fan Motor (ECM)		kW	0.074 + 0.074
Sound Pressure Level	Cooling	dB(A)	49
	Heating	dB(A)	53
External Dimensions (H x W x D)		In / mm	52-11/16 x 41-11/32 x 13+1 1338 x 1050 x 330+25
Net Weight		Lbs / kg	278 / 126
External Finish			Munsell No. 3Y 7.8/11
Refrigerant Pipe Size O.D. — Branch Box	Liquid	In / mm	3/8 / 9.52
	Gas	In / mm	5/8 / 15.88
Max. Refrigerant Line Length		Ft / m	492 (150)
Max. Piping Length for Farthest Indoor Unit		Ft / m	262 (80)
Max. Refrigerant Pipe Height Difference	If IDU is Below ODU	Ft / m	131 (40)
	If IDU is Above ODU	Ft / m	164 (50)
Connection Method Indoor / Outdoor			Flared/Flared
Refrigerant			R410A

* Rating Conditions per AHRI Standard:

Cooling | Indoor: 80°F (27°C) DB / 67°F (19°C) WB
Cooling | Outdoor: 95°F (35°C) DB / 75°F (24°C) WB

Heating at 47°F | Indoor: 70°F (21°C) DB
Heating at 47°F | Outdoor: 47°F (8°C) DB / 43°F (6°C) WB
Heating at 17°F | Indoor: 70°F (21°C) DB
Heating at 17°F | Outdoor: 17°F (-8°C) DB / 15°F (-9°C) WB

*1 Required in windy locations or areas that experience low temperatures.



SPECIFICATIONS: MXZ-4C36NAHZ2-U1 , contd.

Operating Range:

Outdoor	
Cooling	D.B 23 to 115°F . [D.B.-5 to 46°C]*1
Heating	D.B. -13 to 70° F [D.B. -25 to 21° C]

*1. D.B. 5 to 115° F [D.B. -15 to 46° C], when an optional Air Outlet Guide is installed.

Energy Efficiencies:

Indoor Unit Type	SEER	EER	HSPF (I/VV)	COP @ 47°F	COP @ 17°F
Non-ducted	20.0	14.0	11.3/9.2	3.95	NA
Ducted and Non-ducted	18.7	13.2	11.1 /9.0	3.80	NA
Ducted	17.5	12.5	11.0 /8.9	3.70	NA

Multi-zone Indoor/Outdoor Combination Table

- MXZ Compatibility Chart – available on MESCA Tech Info Centre M-Series submittal page

* Refer to indoor unit submittal.

Notes:

- Minimum of two Indoor Units must be connected to the MXZ-4C36NAHZ.
- Minimum installed capacity cannot be less than 12,000 Btu/h.
- System can operate with only one Indoor Unit turned on.
- May connect to any style indoor unit or combination.
- Information provided at 208/230V.
Refer to the MXZ-C Technical & Service Manual for detailed specifications and additional information per Indoor Unit Combination.

SVZ CONNECTION RULES:

- Up to 2 SVZ's may be connected to this system.
- When 2 SVZ's are connected, no additional indoor units can be used.
- When 1 SVZ is connected, additional indoor units can be connected.
- When 1 SVZ is connected, total connected capacity must be less than 100%.

Should this document be altered or changed without MESCA's permission, it becomes null and void. MESCA assumes no responsibility for any consequences in such cases.

Indoor - Outdoor Connection:

- Connect wire from the branch box correctly to the terminal block.
- For future servicing, give extra length to connecting wire.

IMPORTANT
Make sure that the current leakage breaker is one compatible with higher harmonics.
Always use a current leakage breaker that is compatible with higher harmonics as this unit is equipped with an inverter.
The use of an inadequate breaker can cause the incorrect operation of inverter.

Longest length via outdoor units:
 $L_1 + L_2 + L_3 + L_4 + L_5 \leq 500 \text{ m (1640 ft.) (1.25 mm}^2 \text{ or more)}$
 Longest transmission cable length
 $L_1 + L_2, L_3 + L_4, L_5 \leq 200 \text{ m (656 ft.) (1.25 mm}^2 \text{ or more)}$

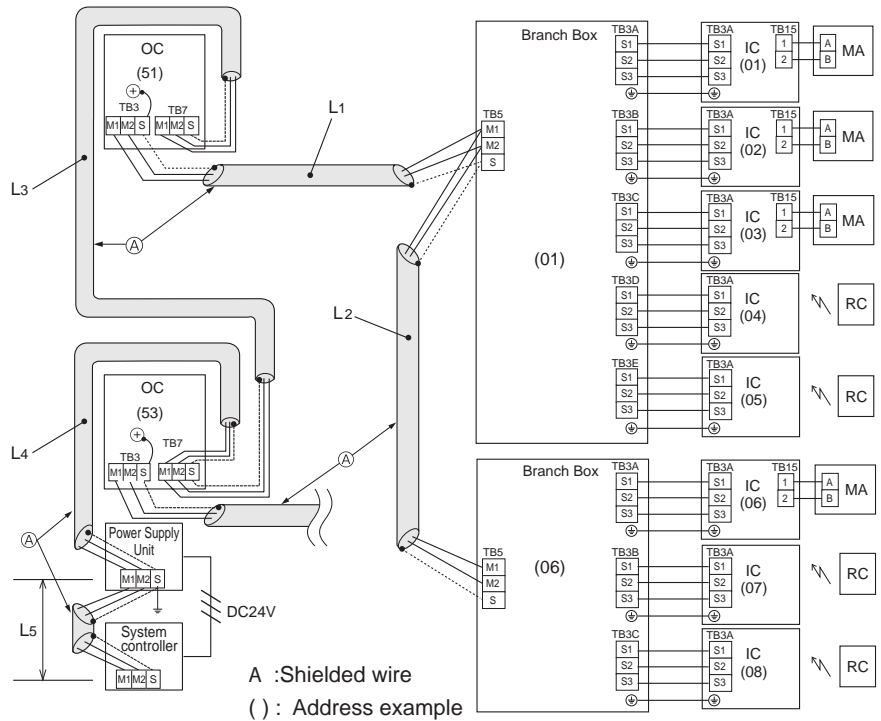

Notes:

Specifications are subject to change without notice.

SYSTEM DESIGN: MXZ-4C36NAHZ2-U1

Should this document be altered or changed without MESCA's permission, it becomes null and void. MESCA assumes no responsibility for any consequences in such cases.

Outdoor unit		MXZ-4C36NAHZ2-U1	
		4HP	
	Rated capacity (kBTU/h)	Cooling	36
		Heating	45
		Refrigerant R410A	
Connectable indoor unit	Capacity		Type 06 to Type 36
	Caution: The indoor unit which rated capacity exceeds 36 kBTU/h (Type 36) can NOT be connected.		
	Number of units		2 to 4 units
Total system wide capacity		33 to 130% of outdoor unit capacity (12 to 46.8 kBTU/h)	
Connectable branch box	Number of units		1* or 2 units (* One SVZ model only)



- MXZ Compatibility Chart – available on MESCA Tech Info Centre M-Series submittal page



Branch box	PAC-MKA52BC	PAC-MKA32BC
Number of branches (Indoor unit that can be connected)	5 branches (MAX. 5 units)	3 branches (MAX. 3 units)

Note: A maximum of 2 branch boxes can be connected to 1 outdoor unit.

Branch Box Combinations	
Three-port	Five-port
1	0
0	1
1	1
2	0
0	2 (Up to 4 IDU)

- If Using One Branch Box
Flare connection employed (No brazing)

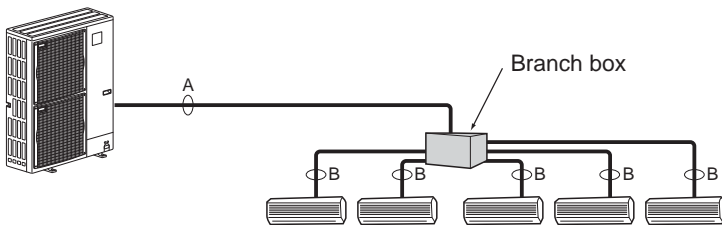

- If Using Two Branch Boxes

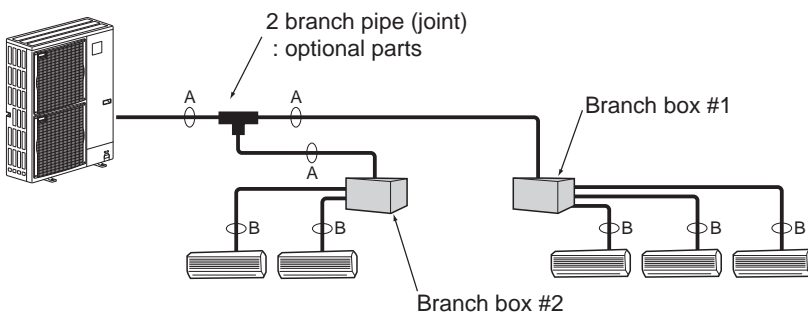

- Installation procedure (2 branch pipe (joint))
Refer to the installation manuals of MSDD-50AR-E and MSDD-50BR-E.

Piping connection size

	A	B
Liquid	$\phi 9.52$ mm (3/8 inch)	The piping connection size differs according to the type and capacity of indoor units. Match the piping connection size of branch box with indoor unit. If the piping connection size of branch box does not match the piping connection size of indoor unit, use optional different-diameter (deformed) joints to the branch box side. (Connect deformed joint directly to the branch box side.)
Gas	$\phi 15.88$ mm (5/8 inch)	

Specifications are subject to change without notice.

DIMENSIONS: MXZ-4C36NAHZ2-U1

Unit: mm <inch>

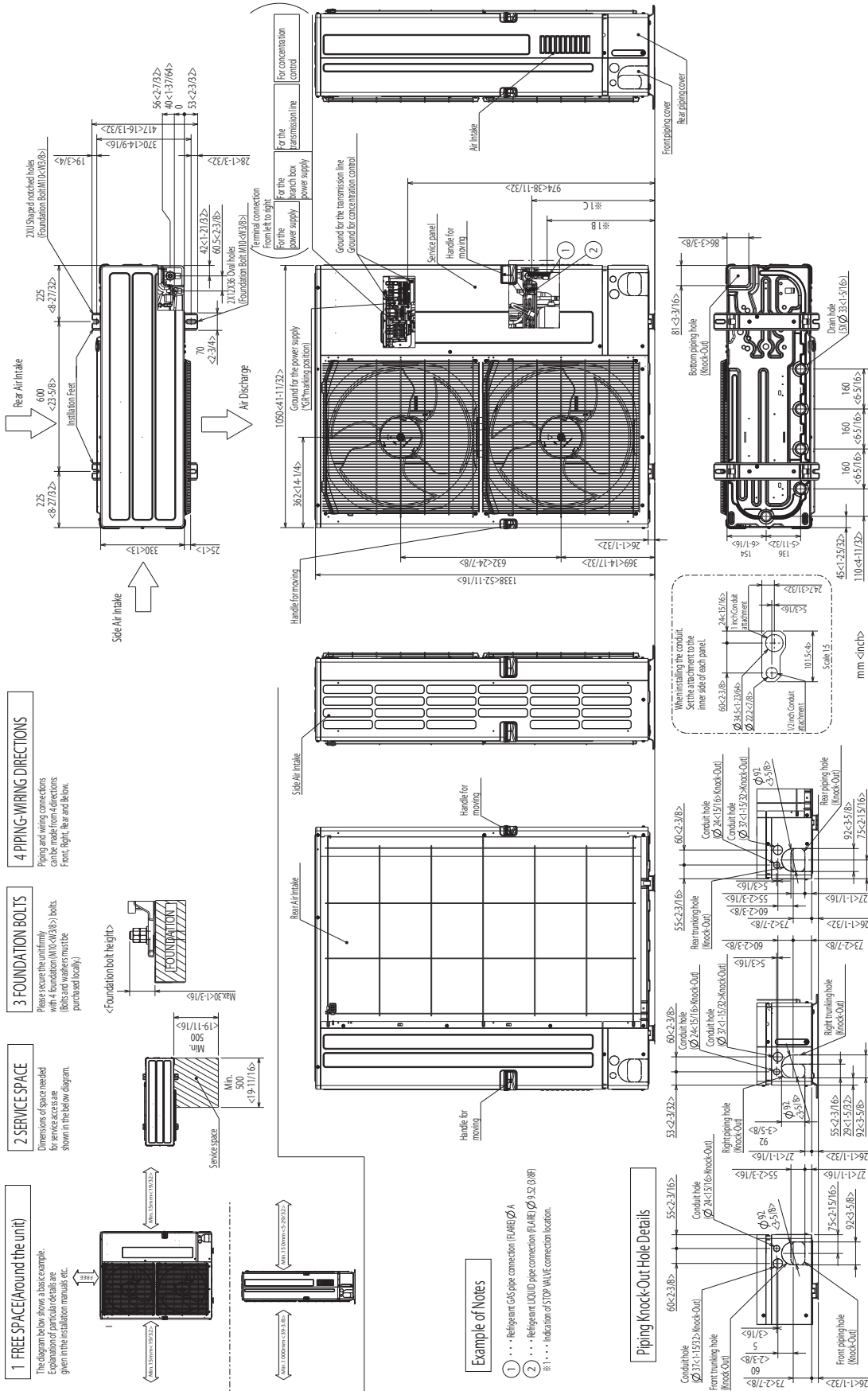

Specifications are subject to change without notice.

Should this document be altered or changed without MESCA's permission, it becomes null and void. MESCA assumes no responsibility for any consequences in such cases.

DIMENSIONS: PAC-MKA32BC AND PAC-MKA52BC BRANCH BOXES

PAC-MKA32BC

Unit: mm <inch>

SUSPENSION BOLT: W3/8(M10)
REFRIGERANT PIPE FLARED CONNECTION Unit: inch

	A	B	C		TO OUTDOOR UNIT
LIQUID PIPE	1/4F	1/4F	1/4F		3/8F
GAS PIPE	3/8F	3/8F	3/8F		5/8F

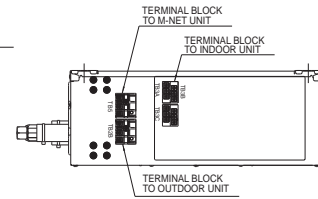
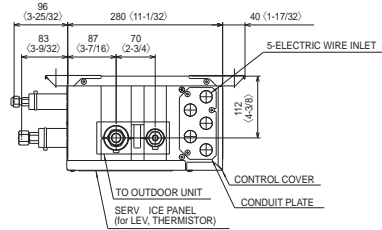
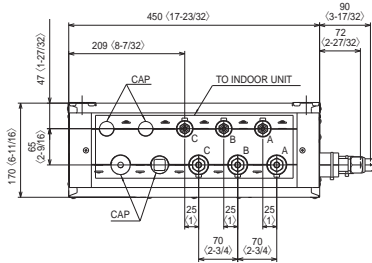
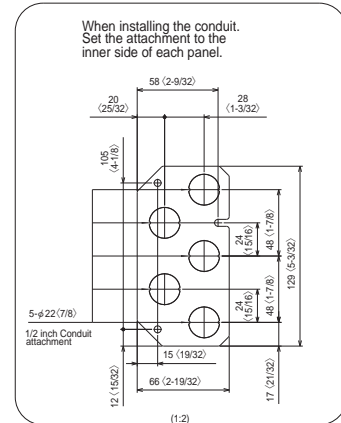
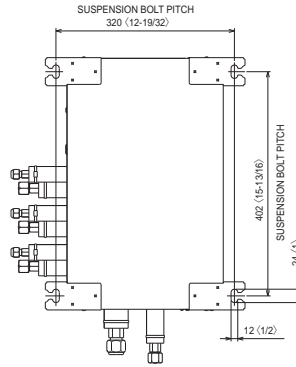

Should this document be altered or changed without MESCA's permission, it becomes null and void. MESCA assumes no responsibility for any consequences in such cases.

PAC-MKA52BC

Unit: mm <inch>

SUSPENSION BOLT: W3/8(M10)
REFRIGERANT PIPE FLARED CONNECTION Unit: inch

	A	B	C	D	E	TO OUTDOOR UNIT
LIQUID PIPE	1/4F	1/4F	1/4F	1/4F	1/4F	3/8F
GAS PIPE	3/8F	3/8F	3/8F	3/8F	1/2F	5/8F

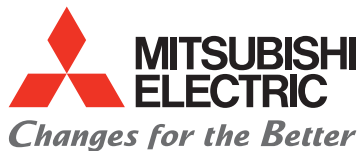
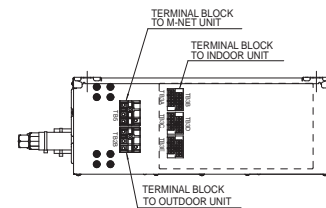
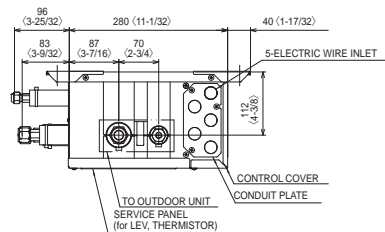
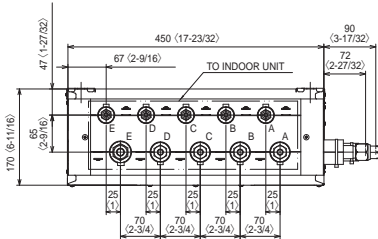
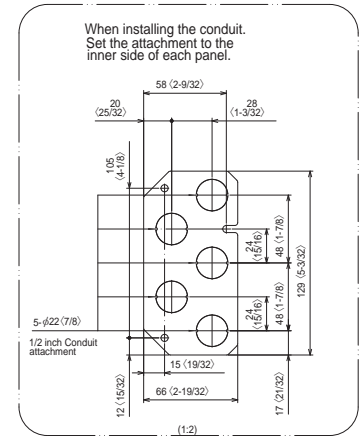
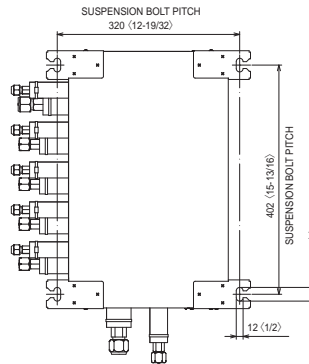

for a greener tomorrow

