

## SUBMITTAL DATA: PEAD-A15AA7 & SUZ-KA15NAR1-TH-H

### 15,000 BTU/H HORIZONTAL-DUCTED HEAT-PUMP SYSTEM

Job Name:	Engineer:
Purchaser:	Application:
Submitted To:	For: <input type="checkbox"/> Reference <input type="checkbox"/> Approval <input type="checkbox"/> Construction
Submitted By:	Location:
System Designation:	Schedule No.:



Indoor Unit: PEAD-A15AA7



Outdoor Unit: SUZ-KA15NAR1-TH-H

**ACCESSORIES:**
**Indoor Unit**

External Heating Adaptor (PAC-YU25HT)

**Controls**

 Wireless Controller (MHK1)  
 Advanced Wired Controller ( PAR-33MAA)  
 Simple Wired Controller (PAC-YT53CRAU) Thermostat  
 Interface (PAC-US444CN)

**Outdoor Unit**

Front Wind Guard (ME-FR-15-17)

**Note: Mitsubishi Electric (MESCA) supports the use of only MESCA supplied and approved Snow Guard / Wind Deflectors / Windscreens and accessories for proper functioning of the unit(s). Use of non-MESCA supported Snow Guard / Wind Deflectors / Windscreens and accessories will affect warranty coverage.**

**SPECIFICATIONS:**

Rated Conditions (Capacity / Input)*		
Cooling	Btu/h / W	15,000 / 1,200
Heating at 47° F	Btu/h / W	21,000 / 1,780
Heating at 17° F	Btu/h / W	13,800 / 1,410

\*1. Rating conditions (cooling)-Indoor : D.B. 26.7°C(80°F), W.B. 19.4°C(67°F) Outdoor : D.B. 35°C(95°F), W.B. 23.9°C(75°F)  
 (heating)-Indoor : D.B. 21.1°C(70°F), W.B. 15.6°C(60°F) Outdoor : D.B. 8.3°C(47°F), W.B. 6.1°C(43°F)  
 \*2. Rating conditions(heating)-Indoor : D.B. 21.1°C(70°F), W.B. 15.6°C(60°F) Outdoor : D.B. -8.3°C(17°F), W.B. -9.4°C(15°F)

Capacity Range		
Cooling	Btu/h	6,300 - 15,000
Heating at 47° F	Btu/h	7,700 - 21,000

AHRI Efficiency Rating	
EER	12.5
SEER	18.6
HSPF IV / V	12.1 / 9.9
COP at 47° F	3.46
COP at 17° F	2.87

## Operating range

		Indoor intake air temperature		Outdoor intake air temperature	
Cooling	Maximum	D.B. 35°C(95°F), W.B. 21.7°C(71°F)		D.B. 46°C(115°F)	
	Minimum	D.B. 19.4°C(67°F), W.B. 13.9°C(57°F)		D.B. -10°C(14°F)	
Heating	Maximum	D.B. 26.7°C(80°F), W.B. 19.4°C(67°F)		D.B. 24°C(75°F), W.B. 18°C(65°F)	
	Minimum	D.B. 21.1°C(70°F), W.B. 15.6°C(60°F)		D.B. -20°C(-4°F), W.B. -21°C(-5°F)	

Electrical Power Requirements	208 / 230V, 1-Phase, 60 Hz
-------------------------------	----------------------------

Minimum Circuit Ampacity (MCA) *	Breaker Size	MOCP (Outdoor)	
Indoor 1.69 AMP	Outdoor 12 AMP	15 AMP	15 AMP

**\*All electrical work shall comply with National (CEC) and local codes and regulations.**

Indoor Unit			
Blower Motor (ECM)	F.L.A.	1.35	
Blower Motor Output	W	85	
SHF / Moisture Removal		0.89 / 1.5 pt./h	
External Static Pressure	In. WG	0.14-0.20-0.28-0.40-0.60	
Drain Lift Mechanism (Included)	H: In.	27-9/16	Drainpipe Size O.D [in. (mm)] - 1-1/4 (32)

Outdoor Unit			
Compressor		DC INVERTER-driven Twin Rotary	
Fan Motor (ECM)	F.L.A.	0.5	
Fan Motor Power	W	55	

Airflow Rate (Low-Mid-Hi)			
Indoor (Cooling)	DRY	CFM	425-512-600
	WET		382-461-540
Outdoor	CLG / HTG		1,243 / 1,229

Sound Pressure Level			
Indoor (Low-Mid-Hi)		dB(A)	30-33-37
Outdoor	Cooling		49
	Heating		51

External Dimensions		
Indoor (H x W x D)	In.(mm)	9-7/8 x 35-7/16 x 28-7/8 (250 x 900 x 732)
Outdoor (H x W x D)		21-5/8 x 31-1/2 x 11-1/4 (550 x 800 x 285)

Net Weight		
Indoor	Lbs.(kg)	62 (28)
Outdoor		80 (36)

External Finish	
Indoor	Galvanized-steel Sheet
Outdoor	Ivory Munsell No. 3Y 7.8 / 1.1

Refrigerant	R410A ; 2lbs., 9oz.
-------------	---------------------

Refrigerant Piping (Flared)		
Liquid (High Pressure)	In.(mm)	1/4 (6.25)
Gas (Low Pressure)		1/2 (12.7)
Maximum Total Refrigerant Pipe Length	Fl. (m)	65 (20)
Maximum Vertical Separation	Fl. (m)	40 (12)

# FAN PERFORMANCE AND CORRECTED AIR FLOW - PEAD-A15AA7

## PEAD-A15AA7

(External static pressure 35Pa) 208-230V 60Hz

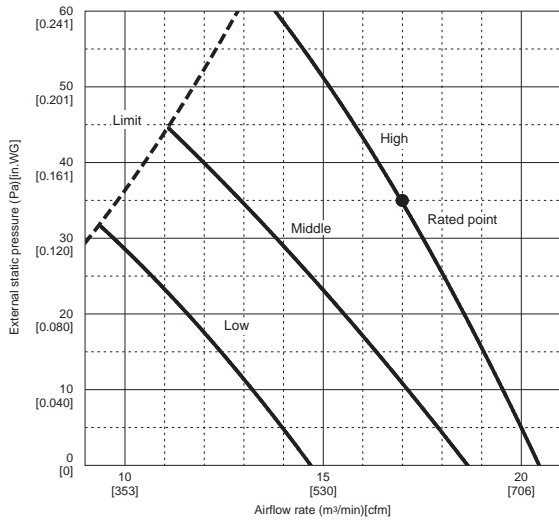

## PEAD-A15AA7

(External static pressure 100Pa) 208-230V 60Hz

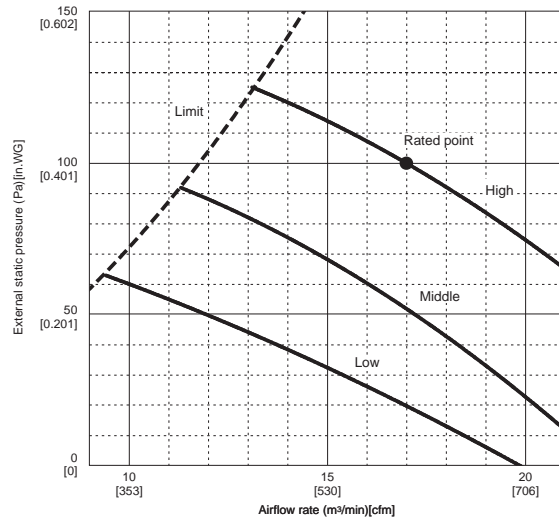

## PEAD-A15AA7

(External static pressure 50Pa) 208-230V 60Hz

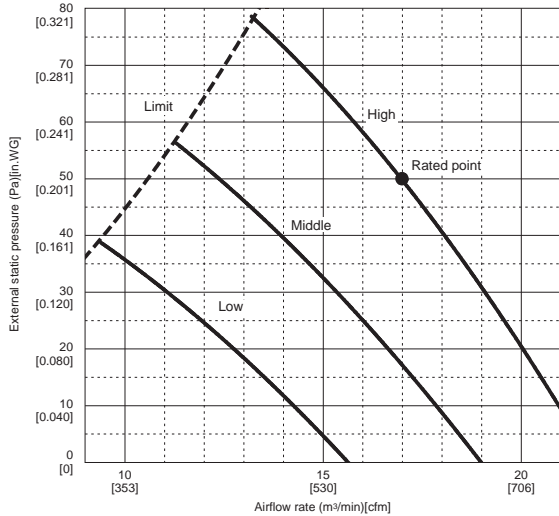

## PEAD-A15AA7

(External static pressure 150Pa) 208-230V 60Hz

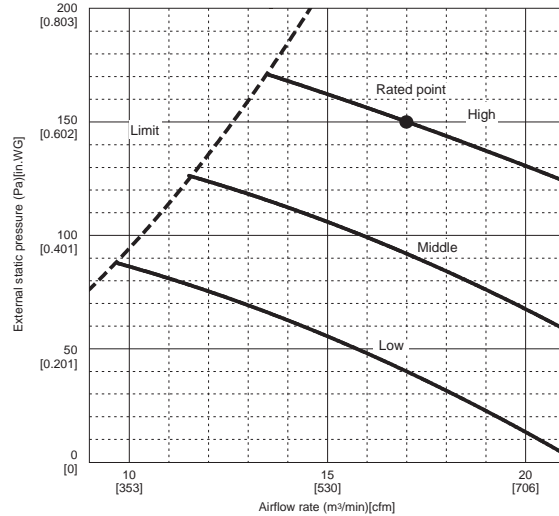

## PEAD-A15AA7

(External static pressure 70Pa) 208-230V 60Hz

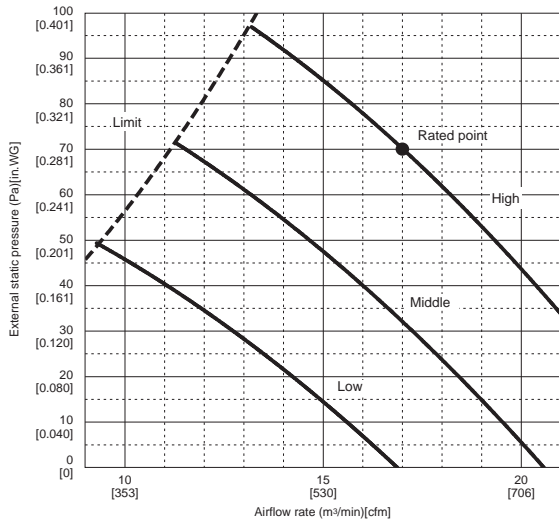

## PEAD-A09/12/15/18AA7

Air filter 208-230V 60Hz

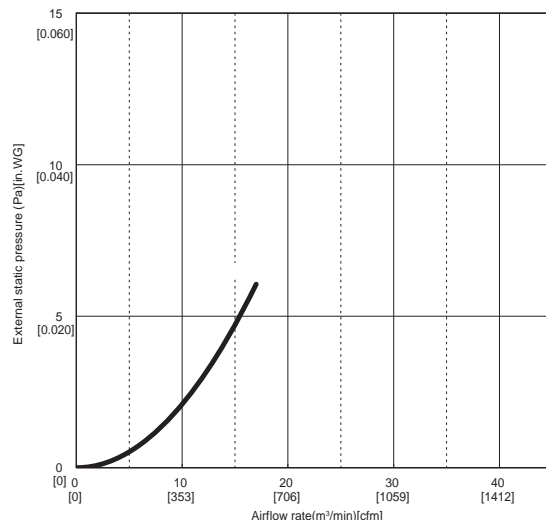

Specifications are subject to change without notice.

Should this document be altered or changed without MESCA's permission, it becomes null and void. MESCA assumes no responsibility for any consequences in such cases.

# DIMENSIONS: PEAD-A15AA7

- Note 1.** Use an M10 screw for the suspension bolt (field supply).
- 2.** Keep the service space for maintenance at the bottom.
- 3.** This drawing is for PEAD-A09-12-15-18 AA7 models have 1 fan.
- 4.** If the inlet duct is used, remove the air filter (supplied with the unit), then install the filter (field supply) at the suction side.
- 5.** Heat air to 0°C (32°F) or higher when taking fresh air with a fresh air intake.

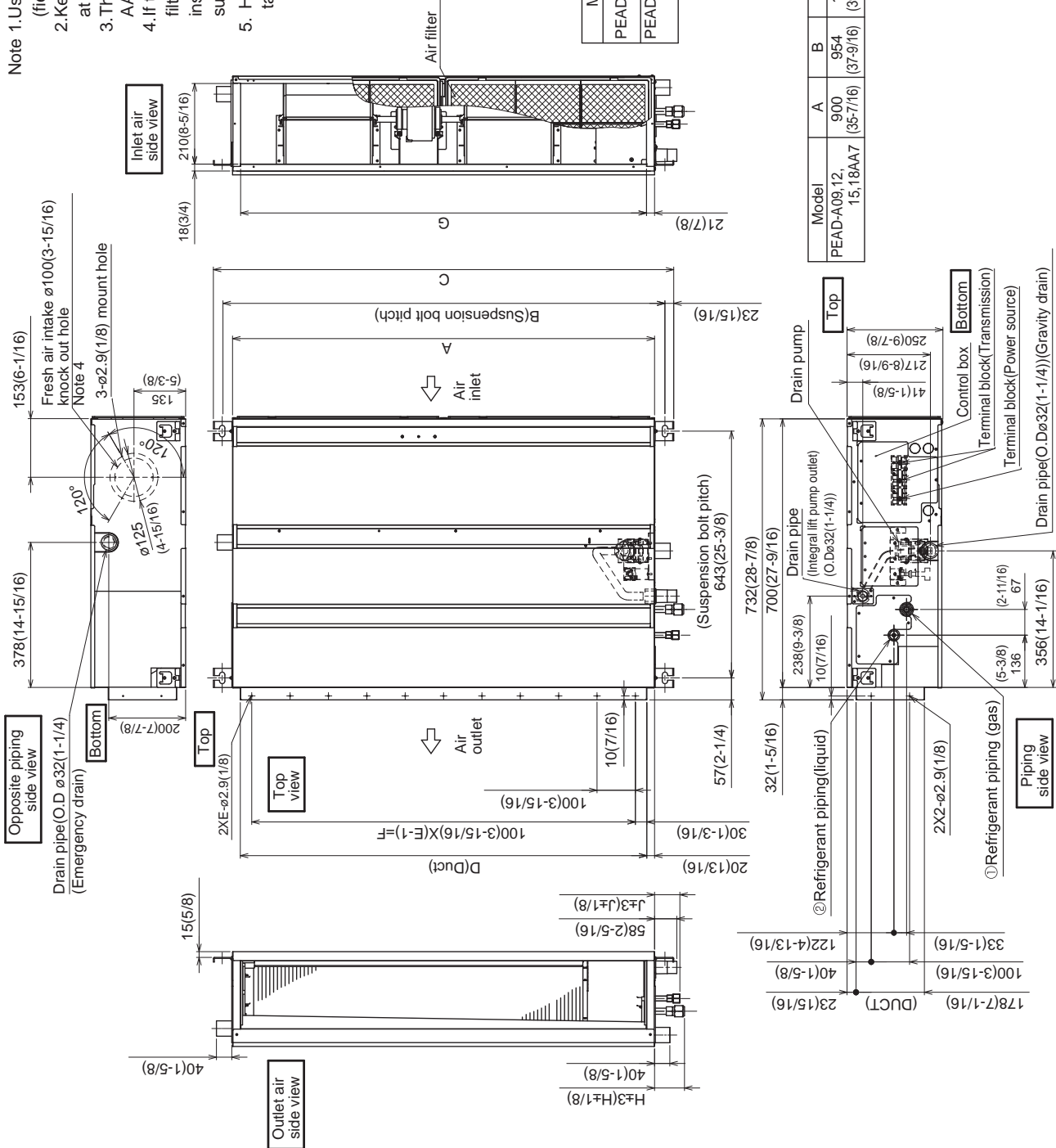

Model	J	① Gas pipe	② Liquid pipe	Unit:mm(in.)
PEAD-A09AA7	62 (2-1/2)	ø9.52 (3/8)	ø6.35 (1/4)	
PEAD-A12,15,18AA7	62 (2-1/2)	ø12.7 (1/2)	ø6.35 (1/4)	

Model	A	B	C	D	E	F	G	H	Unit:mm(in.)
PEAD-A09,12,15,18AA7	900 (35-7/16)	954 (37-9/16)	1000 (39-3/8)	860 (33-7/8)	9	800 (31-1/2)	858 (33-13/16)	72 (2-7/8)	

Specifications are subject to change without notice.

Should this document be altered or changed without MESCA's permission, it becomes null and void. MESCA assumes no responsibility for any consequences in such cases.

Unit:mm (in.)

# DIMENSIONS: PEAD-A15AA7

**[Maintenance access space]**

Secure enough access space to allow for the maintenance, inspection, and replacement of the motor, fan, drain pump, heat exchanger, and control box in one of the following ways.

Select an installation site for the indoor unit so that its maintenance access space will not be obstructed by beams or other objects.

- (1) When a space of 300mm or more is available below the unit between the unit and the ceiling, (Fig.1)
  - Create access door 1 and 2 (450x450mm each) as shown in Fig.2.
  - (Access door 2 is not required if enough space is available below the unit for a maintenance worker to work in.)
- (2) When a space of less than 300mm is available below the unit between the unit and the ceiling. (At least 20mm of space should be left below the unit as shown in Fig.3.)
  - Create access door 1 diagonally below the control box and access door 3 below the unit as shown in Fig.4.
  - Create access door 4 below the control box and the unit as shown in Fig.5.

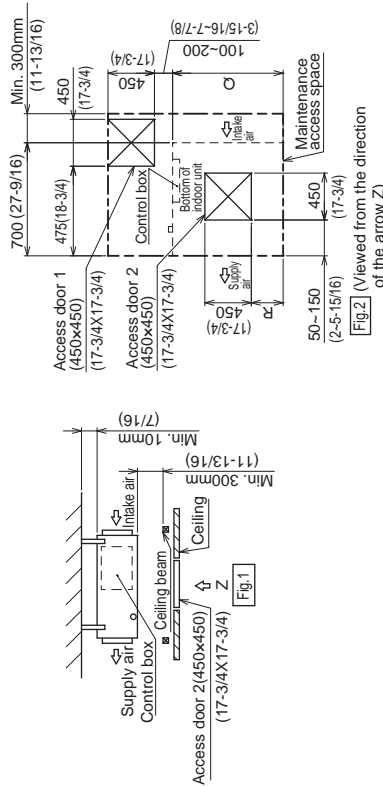
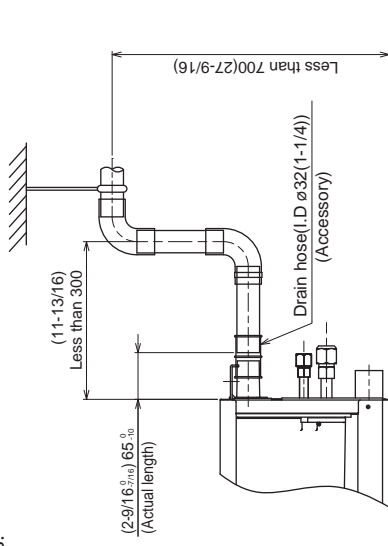

Fig.2 (Viewed from the direction of the arrow Z)

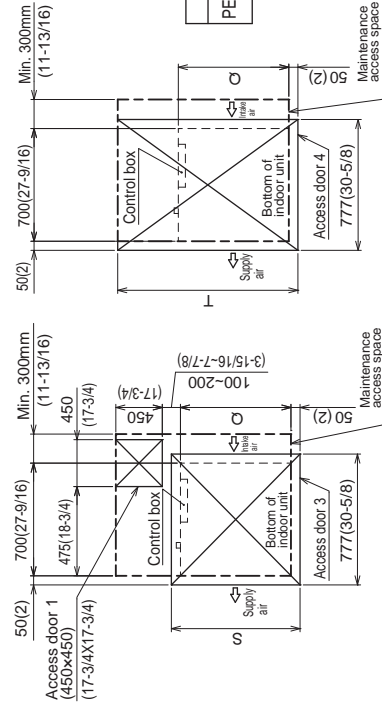

Fig.4 (Viewed from the direction of the arrow Y)

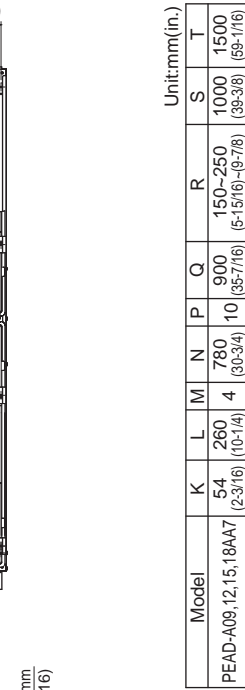

Fig.5 (Viewed from the direction of the arrow Y)

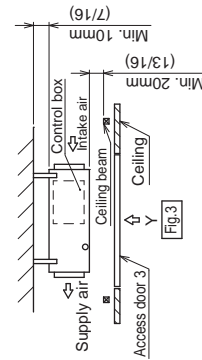
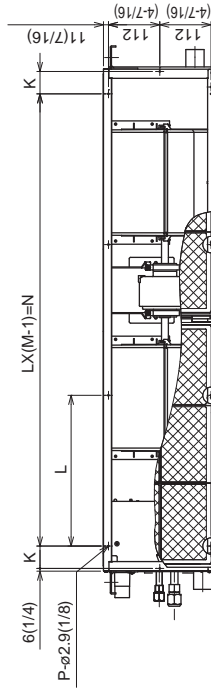

Fig.3



Model	K	L	M	N	P	Q	R	S	T
PEAD-A09,12,15,18AA7	54 (2-3/16)	260 (10-1/4)	4 (3/32)	780 (30-3/4)	10 (35-7/16)	900 (35-7/16)	150-250 (6-15/16)-(9-7/8)	1000 (39-3/8)	1500 (59-1/16)

Unit:mm(in.)

Unit: mm (in.)

Should this document be altered or changed without MESCA's permission, it becomes null and void. MESCA assumes no responsibility for any consequences in such cases.\*

# DIMENSIONS: SUZ-KA15NAR1-TH-H

## REQUIRED SPACE

Basically open 4 in. or more without any obstruction in front and on both sides of the unit.

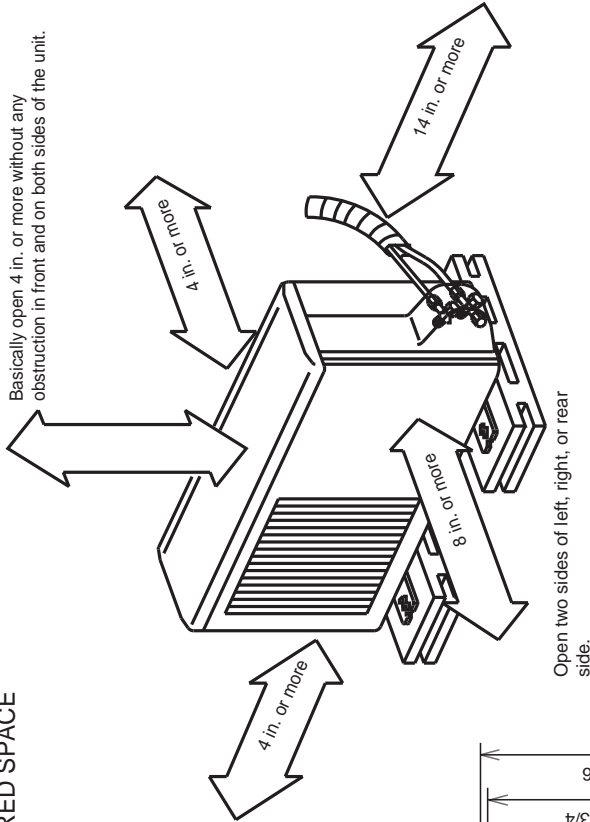

Open two sides of left, right, or rear side.

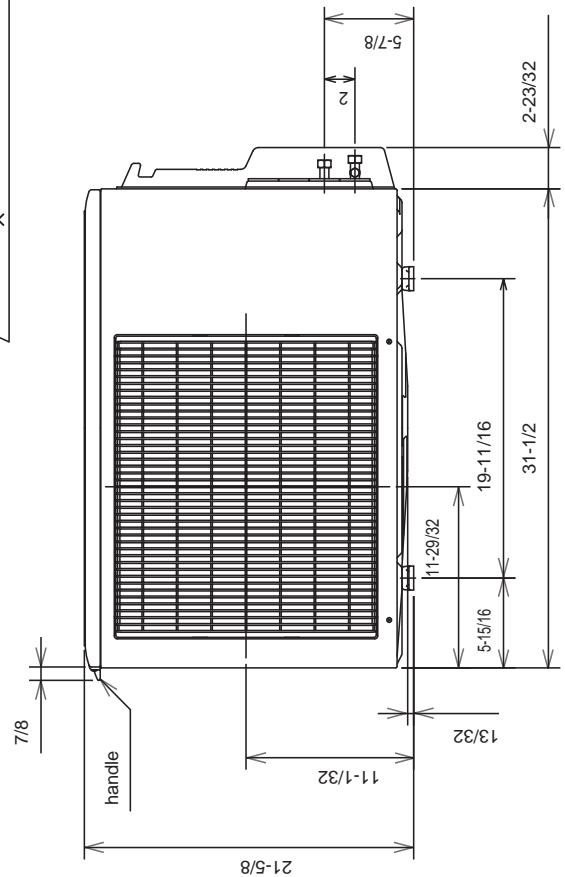
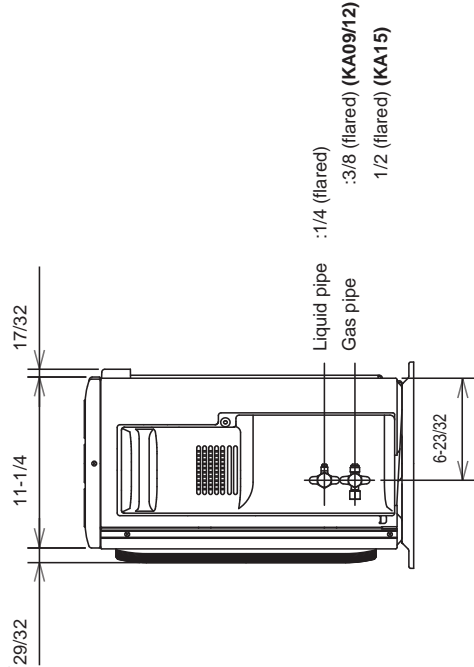
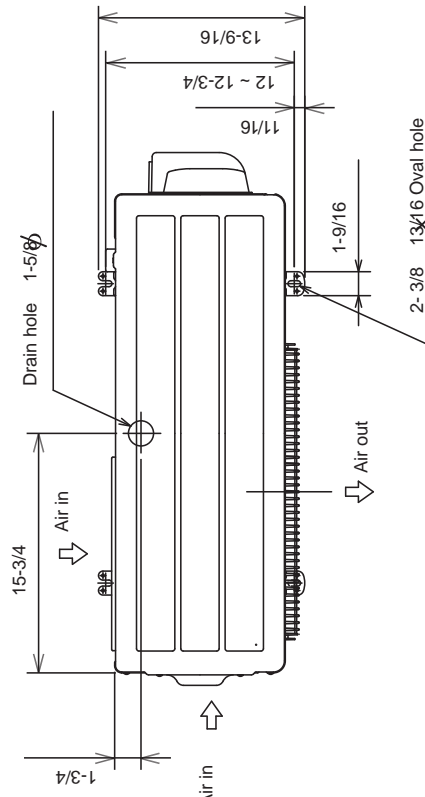
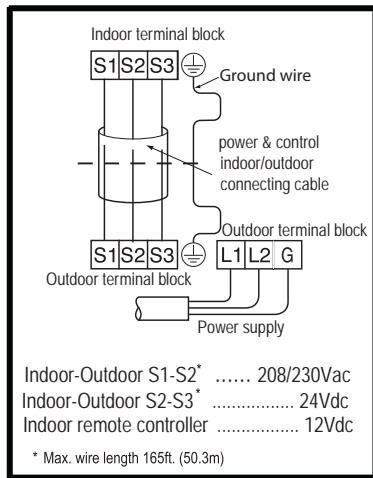

Unit: mm (in.)

Should this document be altered or changed without MESCA's permission, it becomes null and void. MESCA assumes no responsibility for any consequences in such cases.

