

SUBMITTAL DATA: PKA-A18LA-TH & PUY-A18NKA7
18,000 BTU/H WALL-MOUNTED AIR-CONDITIONING SYSTEM

Job Name:	Engineer:
Purchaser:	Application: <input type="checkbox"/> Std. Cooling <input type="checkbox"/> Ultra Low Ambient Cooling
Submitted To:	For: <input type="checkbox"/> Reference <input type="checkbox"/> Approval <input type="checkbox"/> Construction
Submitted By:	Location:
System Designation:	Schedule No.:



Indoor Unit: PKA-A18LA-TH



Outdoor Unit: PUY-A18NKA7 (-BS)

UNIT OPTION:

Standard Model.....PUY-A18NKA7
Seacoast (BS) Model.....PUY-A18NKA7-BS

ACCESSORIES:

Controls

- Wireless Controller (MHK1)
- Advanced Wired Controller (PAR-40MAAU)
- Simple Wired Controller (PAC-YT53CRAU)
- Wireless Remote Controller (PAR-FL32MA)
- Thermostat Interface (PAC-US444CN)
- M-NET Adapter (PAC-SJ96MA-E)

Outdoor Unit

- Front Wind Guard (PFR-12-18)
- Rear Wind Guard (PRE-12-18)
- Side Wind Guard (PSD-12-18)

Note: Mitsubishi Electric (MESCA) supports the use of only MESCA supplied and approved Snow Guard / Wind Deflectors / Windscreens and accessories for proper functioning of the unit/s. Use of non-MESCA supported Snow Guard / Wind Deflectors / Windscreens and accessories will affect warranty coverage.

SPECIFICATIONS:

Rated Conditions (Capacity / Input)*		
Cooling	Btu/h / W	18,000 / 1,680

* Rating Conditions per AHRI Standard:
Cooling | Indoor: 80°F (27°C) DB / 67°F (19°C) WB
Cooling | Outdoor: 95°F (35°C) DB / 75°F (24°C) WB

Capacity Range		
Cooling	Btu/h	8,000 - 18,000

Operating Range	
Cooling	-40F** (-40.0°C) to 115°F (46°C) DB

** Windscreens required for cooling operation below 23°F (-5°C)

AHRI Efficiency Rating	
EER	10.7
SEER	19.8

Electrical Power Requirements	208 / 230V, 1-Phase, 60 Hz
-------------------------------	----------------------------

Minimum Circuit Ampacity (MCA) *	Breaker Size	MOCP (Outdoor)
Indoor 1 AMP	Outdoor 11 AMP	15 AMP
		28 AMP

*** All electrical work shall comply with National (CEC) and local codes and regulations.**

Indoor Unit			
Fan Motor (ECM)	F.L.A.	0.19	
Fan Motor Output	W	30	
SHF		0.64 / 0.73**	
Field Drainpipe Size O.D.	In.(mm)	5/8 (16)	Moisture Removal - 5.8pt./h

Outdoor Unit		
Compressor	DC INVERTER-driven Twin Rotary	
Fan Motor (ECM)	F.L.A.	0.5
Fan Motor Power	W	46

Airflow Rate (Low-Mid1-Mid2-Hi)			
Indoor (Cooling)	DRY	CFM	265-310-375-450
	WET		215-255-320-375
Outdoor	DRY		1,590

Sound Pressure Level		
Indoor (Low-Mid1-Mid2-Hi)	dB(A)	34-39-44-48
Outdoor Cooling		44

External Dimensions		
Indoor (H x W x D)	In.(mm)	11-25/32 x 35-23/64 x 9-11/32 (299 x 898 x 237)
Outdoor (H x W x D)		24-13/16 x 31-13/16 + 7/16 x 11-3/16 (630 x 809 + 62 x 300)

Net Weight		
Indoor	Lbs.(kg)	28 (12.7)
Outdoor		99 (44)

External Finish	
Indoor	White Munsel No. 0.7PB 9.2/0.4
Outdoor	Ivory Munsell No. 3Y 7.8 / 1.1

Refrigerant	R410A ; 4lbs.,14oz. (2.2kg)
-------------	-----------------------------

Refrigerant Piping (Flared)		
Liquid (High Pressure)	In.(mm)	1/4 (6.35)
Gas (Low Pressure)		1/2 (12.7)
Maximum Total Refrigerant Pipe Length	Ft. (m)	165 (50)
Maximum Vertical Separation	Ft. (m)	100 (30)

** Asternisk denotes performance specification based on ASHRAE / ANSI Standard 127-2012 for Data Processing and Information Technology Equipment Space Room Cooling

Should this document be altered or changed without MESCA's permission, it becomes null and void. MESCA assumes no responsibility for any consequences in such cases.

DIMENSIONS: PUY-A18NKA7

Should this document be altered or changed without MESCA's permission, it becomes null and void. MESCA assumes no responsibility for any consequences in such cases.

Unit: mm (in.)

Free space around the outdoor unit
(basic example)

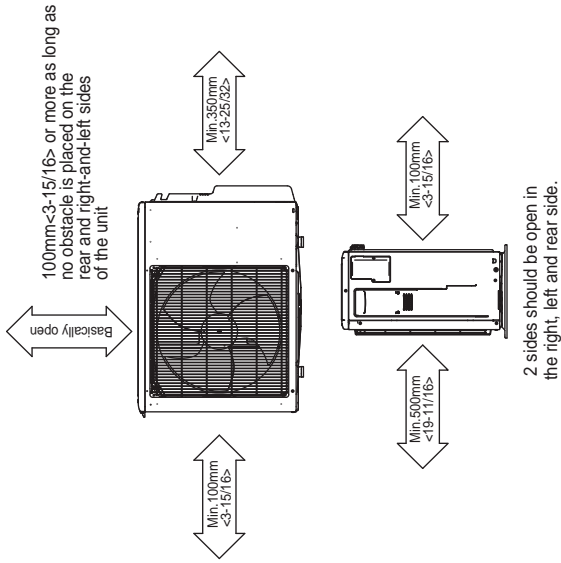

FOUNDATION BOLTS

Please secure the unit firmly with 4 foundation (M10<W3/8>) bolts. (Bolts, washers and nut must be purchased locally).

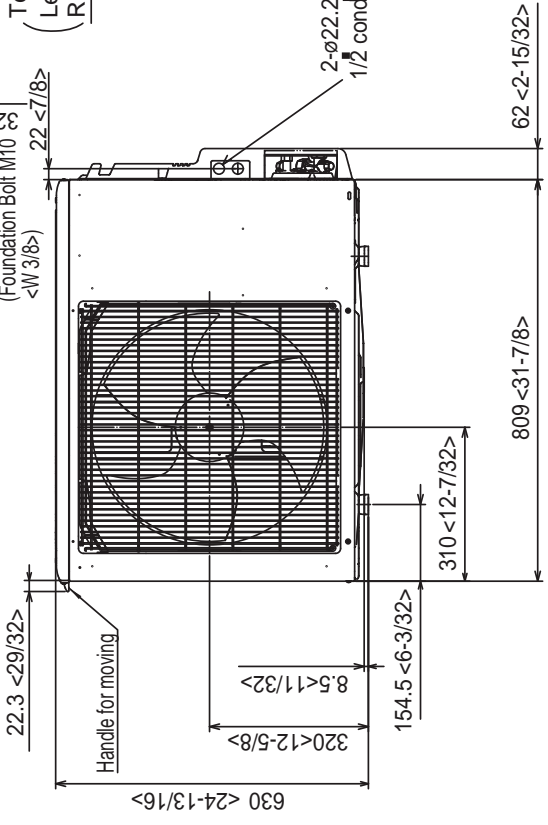
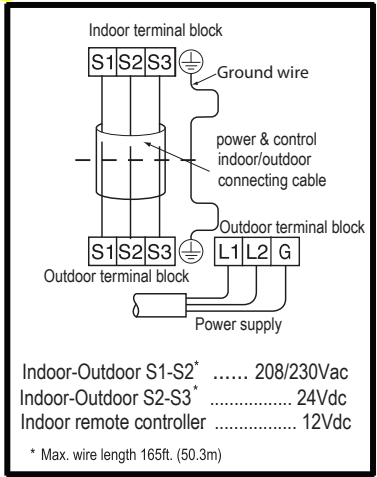
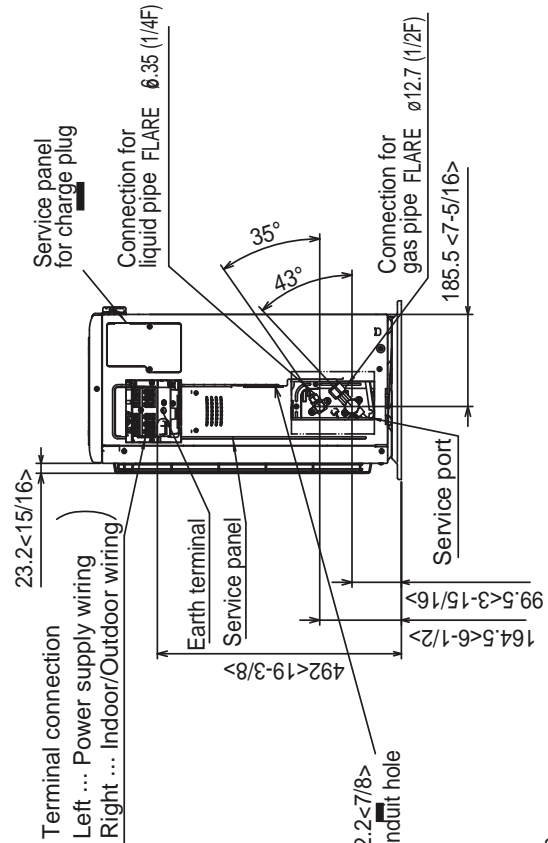
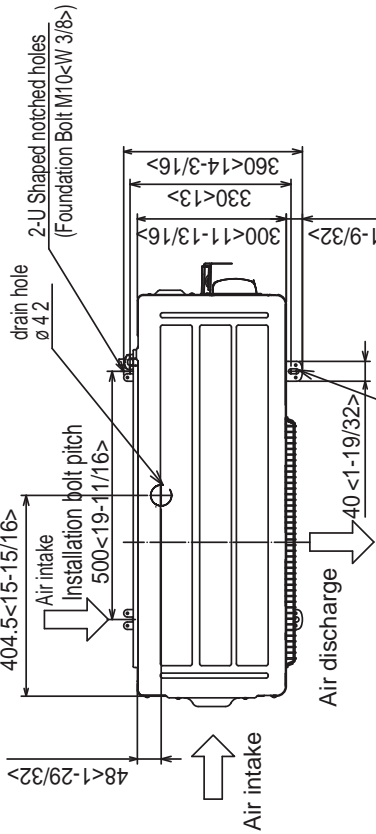
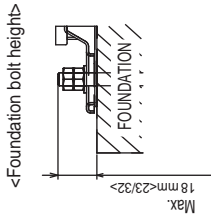

for a greener tomorrow

