

**SUBMITTAL DATA: PLA-A42EA7 & PUY-A42NKA7**  
42,000 BTU/H CEILING CASSETTE AIR-CONDITIONING SYSTEM

Job Name:	Engineer:
Purchaser:	Application:    Std. Cooling            Ultra Low Ambient Cooling
Submitted To:	For: <input type="checkbox"/> Reference <input type="checkbox"/> Approval <input type="checkbox"/> Construction
Submitted By:	Location:
System Designation:	Schedule No.:



Indoor Unit: PLA-A42EA7



Outdoor Unit: PUY-A42NKA7 (-BS)

**UNIT OPTION:**

Standard Model.....PUY-A42NKA7  
Seacoast (BS) Model.....PUY-A42NKA7-BS

**ACCESSORIES:**

**Indoor Unit**

Multifunction Casement / High Efficiency Filter (PAC-SJ41TM-E / PAC-SH59KF-E)  
Grille with 3D i-see Sensor™ (PLP-41EAEU) - (Required ordered separately)

**Optional Controls**

- Wireless Controller (MHK1)
- Advanced Wired Controller (PAR-40MAA)
- Simple Wired Controller (PAC-YT53CRA)
- Thermostat Interface (PAC-US444CN)
- Wireless Remote Controller (PAR-FL32MA)(Requires Signal Receiver (PAR-SR4LU-E))
- M-NET Adapter (PAC-SJ95MA-E)

**Outdoor Unit**

- Rear Snow Guard (SG-1-RE)
- Side Snow Guard (SG-1-SD)
- Front Wind Deflector (x2 required) (CM-S-FR-NKMU)
- Front Wind Blocker (x2 per box) (CM-S-BLK-NKMU)

**Note: Mitsubishi Electric (MESCA) supports the use of only MESCA supplied and approved Snow Guard / Wind Deflectors / Windscreens and accessories for proper functioning of the unit(s). Use of non-MESCA supported Snow Guard / Wind Deflectors / Windscreens and accessories will affect warranty coverage.**

**SPECIFICATIONS:**

Rated Conditions (Capacity / Input)*		
Cooling	Btu/h / W	42,000 / 3,590

\* Rating Conditions per AHRI Standard:  
Cooling | Indoor: 80°F (27°C) DB / 67°F (19°C) WB  
Cooling | Outdoor: 95°F (35°C) DB / 75°F (24°C) WB

Capacity Range		
Cooling	Btu/h	16,000 - 42,000

Operating Range		
Cooling		-40F** (-40.0°C) to 115°F (46°C) DB

\*\* Windscreens required for cooling operation below 23°F (-5°C)

AHRI Efficiency Rating	
EER	11.6
SEER	21.0

Electrical Power Requirements	
	208 / 230V, 1-Phase, 60 Hz

Minimum Circuit Ampacity (MCA) *		Breaker Size	MOCP (Outdoor)
Indoor 2 AMP	Outdoor 25 AMP	30 AMP	31 AMP

**\*All electrical work shall comply with National (CEC) and local codes and regulations.**

Indoor Unit		
Fan Motor (ECM)	F.L.A.	0.95
Fan Motor Output	W	120
SHF / Moisture Removal		0.79 / 7.9 pt./h
Drain Lift Mechanism (Included)	H: In.	33-7/16
Field Drainpipe Size O.D.	In.(mm)	1-1/4 (32)

Outdoor Unit		
Compressor		DC INVERTER-driven Twin Rotary
Fan Motor (ECM)	F.L.A.	0.5 + 0.5
Fan Motor Power	W	74

Airflow Rate (Low-M1-M2-Hi)			
Indoor (Cooling)	DRY	CFM	740-920-1060-1200
	WET		700-880-1020-1160
Outdoor	DRY		3880

Sound Pressure Level		
Indoor (Low-M1-M2-Hi)	dB(A)	34-38-42-45
Outdoor    Cooling		52

External Dimensions			
Indoor (H x W x D)	In.(mm)	11-3/4 [1-9/16] x 33-3/32 [37-13/32] x 33-3/32 [37-13/32]	
Grille ((H x W x D))		(298 [40] x 840 [950] x 840 [950])	
Outdoor (H x W x D)		52-11/16 x 41-5/16 x 13 + 1-3/16 (1,338 x 1050 x 330 + 30)	

Net Weight		
Indoor (Unit / Grille)	Lbs.(kg)	56 / 11 (25 / 5)
Outdoor		211 (96)

External Finish	
Indoor	Munsell 1.0Y 9.2/0.2
Outdoor	Ivory Munsell No. 3Y 7.8 / 1.1

Refrigerant	
	R410A ; 10lbs., 6oz. (4.7kg)

Refrigerant Piping (Flared)		
Liquid (High Pressure)	In.(mm)	3/8 (9.52)
Gas (Low Pressure)		5/8 (15.88)
Maximum Total Refrigerant Pipe Length	Fl. (m)	225 (69)
Maximum Vertical Separation	Fl. (m)	100 (30)

Specifications are subject to change without notice.

Should this document be altered or changed without MESCA's permission, it becomes null and void. MESCA assumes no responsibility for any consequences in such cases.

# DIMENSIONS: PLA-A42EA7

Unit: in. (mm)

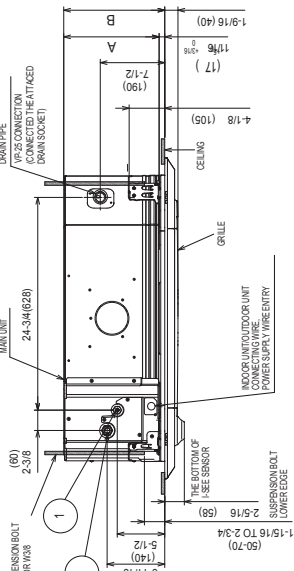
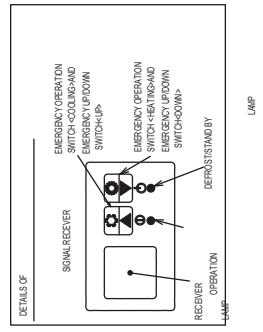
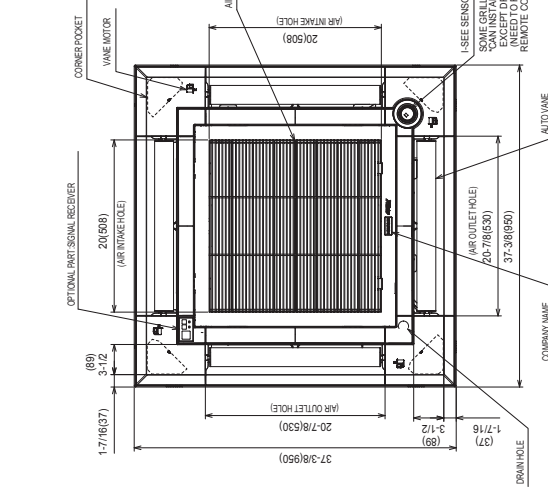
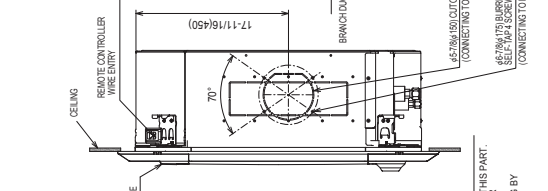
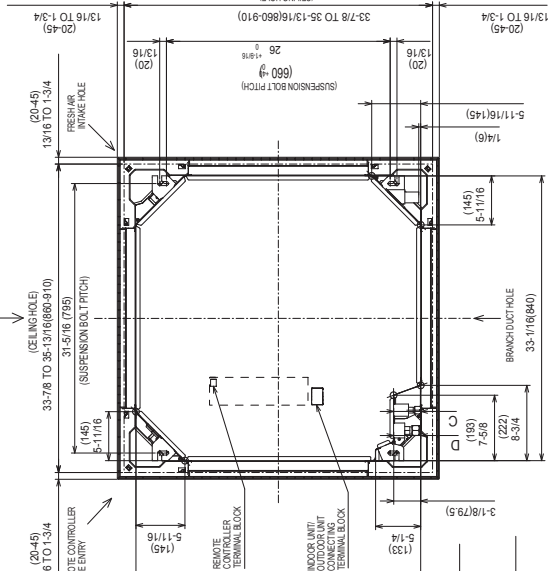
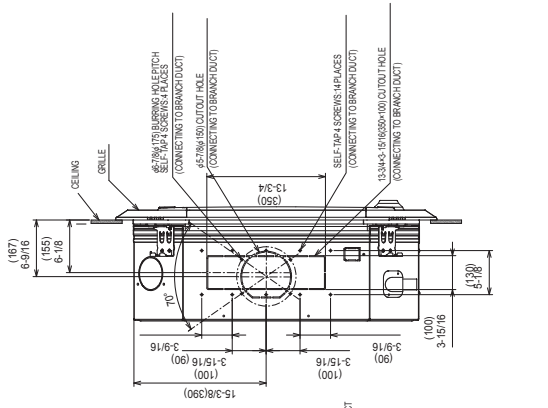
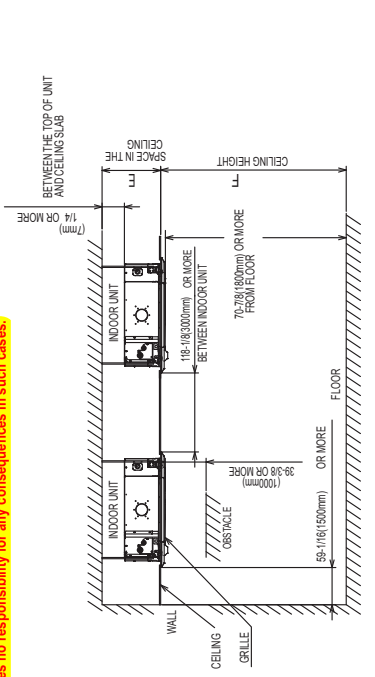
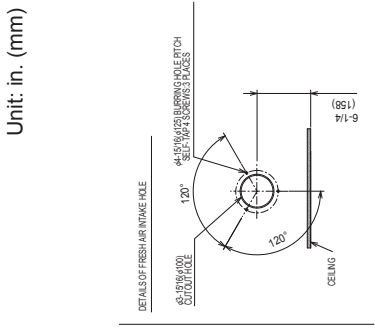

- NOTE 1. CHOOSE THE GRILLE AMONG THE DEDICATED GRILLES.
  2. REINFORCE THE SUSPENSION BOLT FOR EARTHQUAKE-RESISTANCE AS NEEDED.
  3. FOR THE SUSPENSION BOLT, USE M10 OR W3/8. (PROCURED AT THE LOCAL SITE.)
  4. FOR DRAIN PIPE, USE VP-25(O.D. m:1/4"/(6.32) PVC TUBE). DRAIN PUMP INCLUSION. RAISE IS MAX 33-7/16"(850mm) FROM THE CEILING.
  5. ELECTRICAL BOX MAY BE REMOVED FOR THE SERVICE PURPOSE.
- MAKE SURE TO SLACK THE ELECTRICAL WIRE LITTLE BIT FOR CONTROL/POWER WIRES CONNECTION.
  6. THE HEIGHT OF THE INDOOR UNIT IS ABLE TO BE ADJUSTED WITH THE GRILLE ATTACHED.
  7. REQUIRES "E" OR MORE SPACE BETWEEN TRANSOM AND CEILING FOR THE INSTALLATION.
  8. WHEN INSTALLING THE BRANCH DUCTS, BE SURE TO INSULATE ADEQUATELY.
  9. OTHERWISE CONDENSATION AND DRIPPING MAY OCCUR (IT BECOMES THE CAUSE OF DROPLET OR DRIPLETT DRIPPING).
  10. FOR THE INSTALLATION OF THE OPTIONAL HIGH EFFICIENCY FILTER OR MULTI-FUNCTIONAL CASEMENT, REFER TO SPECIAL DRAWING.

① SEE SENSOR CORNER PANEL. IF YOU HAVE THIS PART, YOU CAN INSTALL DRAIN PIPE CORNER EXCEPT DRAIN PIPE CORNER REMOTE CONTROLLER.

MODELS	A	B	C	D	E	F
PLA-A12/18EA7	9-1/2 (241)	10-3/16 (268)	3/8 (9.5)	10-7/16 (268) OR MORE	10-7/16 (268) OR MORE	10-1/8 (260) OR LESS
PLA-A24~42EA7	11-1/8 (288)	11-3/4 (297)	3-1/8 (79.5)	12-3/8 (320) OR MORE	12-3/8 (320) OR MORE	11-7/8 (298) OR LESS

# DIMENSIONS: PUY-A42NKA7

Unit: mm (in.)

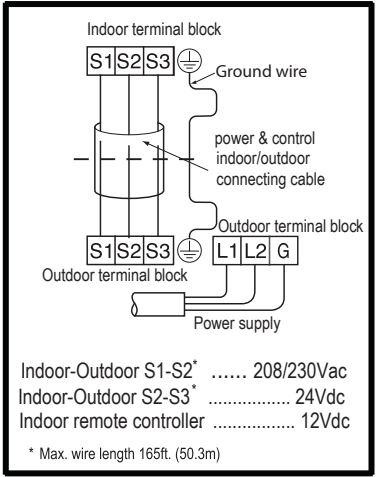
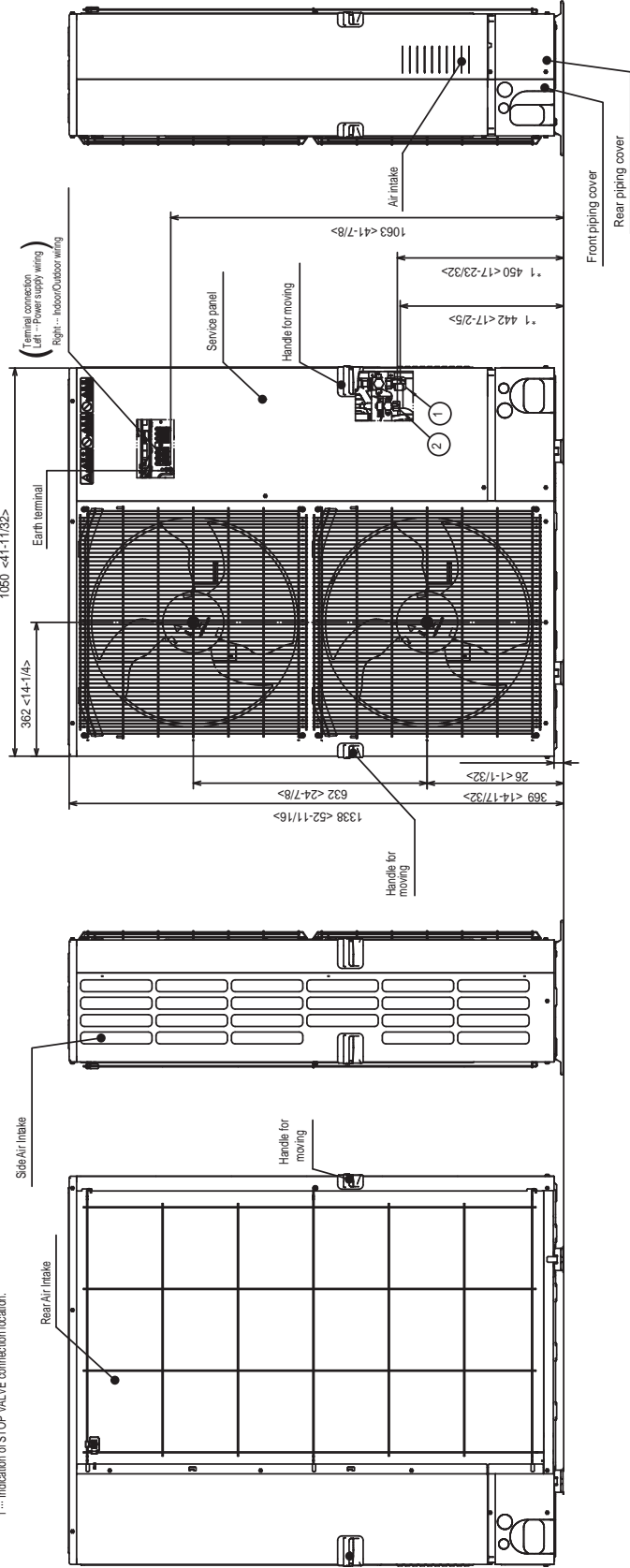
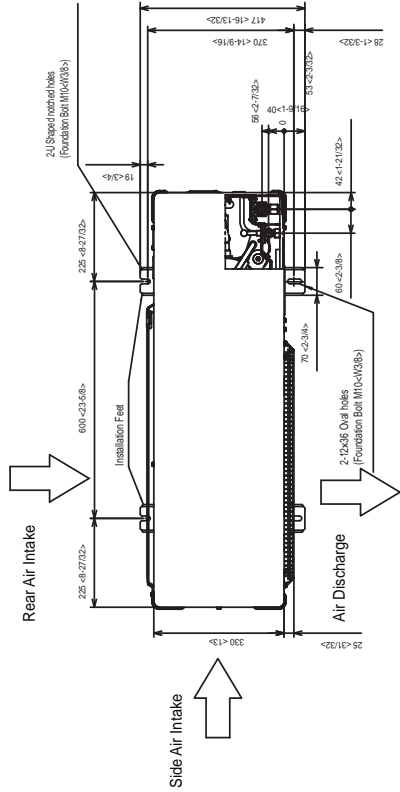

**Example of Notes**

① ... Refrigerant GAS pipe connection (FLARE) ø15.88(5/8F)  
 ② ... Refrigerant LIQUID pipe connection (FLARE) ø3.52(3/8F)  
 \*1 ... Indication of STOP VALVE connection location.

Should this document be altered or changed without MESCA's permission, it becomes null and void. MESCA assumes no responsibility for any consequences in such cases.

