

Job Name:

Schedule Reference:

Date:

ACCESSORIES



WATER-SOURCE VRF HEAT PUMP SYSTEM

Standard Installation (*1) PQHY-P72ZLMU-A1
 Geothermal Installation (*1)(*2) PQHY-P72ZLMU-A1

T-Branch Joint (≤ 72,000 Btu/h) CMY-Y102SS-G2
 T-Branch Joint (73,000 - 144,000 Btu/h) CMY-Y102LS-G2

Header - 4 Branch (Capacity: ≤ 72,000 Btu/h) CMY-Y104C-G
 Header - 8 Branch (Capacity: ≤ 144,000 Btu/h) CMY-Y108C-G
 Header - 10 Branch (Capacity: ≤ 234,000 Btu/h) CMY-Y1010C-G

Specifications		Model Name
Unit Type		PQHY-P72ZLMU-A1
Nominal Cooling Capacity (575V)	(*1) Btu/h	72,000
Nominal Heating Capacity (575V)	(*1)(*2) Btu/h	80,000
Operating Temperature Range	Cooling (Indoor)	59~75° F (15~24° C) WB
	Heating (Indoor)	59~81° F (15~27° C) DB
Operating Water Temperature Range	Cooling (*3)	50~113° F (10~45° C)
	Heating (*3)	50~113° F (10~45° C)
External Dimensions (H x W x D)	In. (mm)	43-5/16 x 34-11/16 x 21-11/16 (1100 x 880 x 550)
Net Weight	Lbs. (kg)	413 (187)
External Finish		Galvanized steel sheet
Electrical Power Requirements	Voltage, Phase, Hertz	575V, 3-phase, 60Hz
Minimum Circuit Ampacity (MCA) *	A	5
Maximum Overcurrent Protection (MOP)	A	15
<i>Circulating Water (quality must meet regulations)</i>		
Flow Rate	GPM	25.4
Pressure Drop	psi	3.48
Operation Volume Range	GPM	13.2 - 31.7
Maximum Water Pressure	psi	290
Water-source Connection for Inlet and Outlet	In.	NPT1-1/2 Screw (Install strainer (more than 50 meshes) at water inlet piping of the unit)
Piping Diameter (Brazed) (In. / mm)	High Pressure (Liquid)	3/8 / 9.52
	Low Pressure (Gas)	3/4 / 19.05
Max. Total Refrigerant Line Length	Ft.	1,804
Max. Refrigerant Line Length (Between ODU & IDU)	Ft.	541
Max. Control Wiring Length	Ft.	1,640
Indoor Unit	Total Capacity	50~130%
	Model / Quantity	P06~P96/1~15
Sound Pressure Levels	dB(A)	46
Compressor Operating Range		24% - 100%
Compressor Type x Quantity		Inverter scroll hermetic compressor x 1
Refrigerant		R410A x 11 lbs. + 1 oz. (5.0 kg)
Protection Devices	High Pressure	High pressure sensor, High pressure switch at 4.15 MPa (601 psi)
	Inverter Circuit	Over-heat protection, Over-current protection
	Compressor	Over-heat protection
AHRI Ratings (Ducted/Non-Ducted)	EER	17.4 / 20.7
	IEER	24.2 / 28.1
	COP	5.62 / 6.15

Should this document be altered or changed without MESCA's permission, it becomes null and void. MESCA assumes no responsibility for any consequences in such cases.

NOTES: (*1) <CITY MULTI indoor unit>
 Nominal cooling conditions (Test conditions are based on AHRI 1230)
 Indoor: 81°F DB, 66°F WB (27°C DB, 19°C WB),
 Water temperature: 86°F (30°C)
 Brine concentration 0%

(*2) <PWFY-P36/72NMU-E-AU>
 Nominal cooling conditions
 Circulating water Temp.: 86°F (30°C)
 Pipe length: 25 ft. (7.6 m)
 Level difference: 0 ft. (0 m)
 Inlet water Temp.: 149°F (23°C)
 Water flow rate: 1.93 m³/h (8.3 gpm) <P36> / 3.86 m³/h (16.6 gpm) <P72>
 Brine concentration: 0%

Nominal heating conditions (Test conditions are based on AHRI 1230)
 Indoor: 68°F DB, (20°C DB),
 Water temperature: 68°F (20°C)
 Brine concentration 0%

Nominal heating conditions
 Circulating water Temp.: 68°F (20°C)
 Pipe length: 25 ft. (7.6 m)
 Level difference: 0 ft. (0 m)
 Inlet water Temp.: 86°F (30°C)
 Water flow rate: 2.15 m³/h (9.2 gpm) <P36> / 4.30 m³/h (18.5 gpm) <P72>
 Brine concentration: 0%

Note: Mitsubishi Electric (MESCA) supports the use of only MESCA supplied and approved accessories for proper functioning of the unit(s). Use of non-MESCA supported accessories will affect warranty coverage.

(*3) If using circulating water temperatures between 23° and 50° F, Dip switch 3-9 must be turned on and glycol (antifreeze) must be added to the water loop to prevent freezing down to 5° F.

Notes:

Specifications are subject to change without notice.

* All electrical work shall comply with National (CEC) and local codes and regulations.

Model: PQHY-P72ZLMU-A1 – DIMENSIONS

Unit: mm(in)

- <Accessories>
- Refrigerant (Liquid) conn. pipe 1pc.
(P72/P96/P120 ; Packaged in the accessory kit)
 - Refrigerant (Gas) conn. elbow 1pc.
(P72/P96/P120 ; Packaged in the accessory kit)
 - Water stopper(Liquid,Gas) 1pc. each
(P72/P96/P120 ; Packaged in the accessory kit)
 - Sealing material for water stopper (Liquid,Gas) 1pc. each
(P72/P96/P120 ; Packaged in the accessory kit)
 - Sealing material for field piping (Liquid,Gas) 1pc. each
(P72/P96/P120 ; Packaged in the accessory kit)
 - Sealing material for drain socket 1pc.
(P72/P96/P120 ; Packaged in the accessory kit)
 - Pipe cover for gas 1pc.
(P72/P96/P120 ; Packaged in the accessory kit)

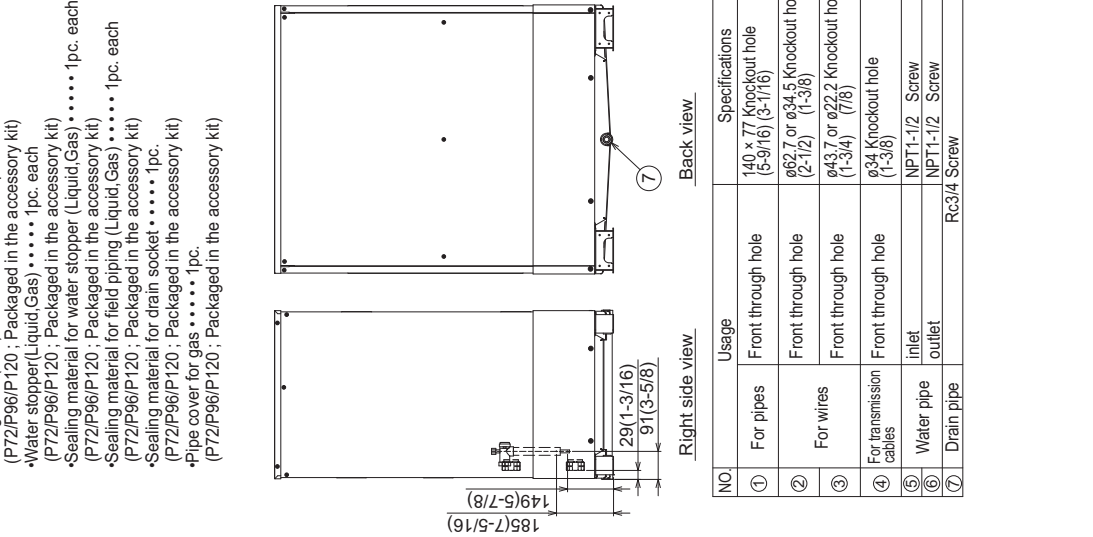

NO.	Usage	Specifications
①	For pipes	Front through hole 140 x 77 Knockout hole (5-9/16) (3-1/16)
②	For wires	Front through hole 962.7 or ø34.5 Knockout hole (2-1/2) (1-3/8)
③	For transmission cables	Front through hole 943.7 or ø22.2 Knockout hole (1-3/4) (7/8)
④	Water pipe inlet	Front through hole ø34 Knockout hole (1-3/8)
⑤	Water pipe outlet	NPT1-1/2 Screw NPT1-1/2 Screw
⑦	Drain pipe	Rc3/4 Screw

- Note 1. Close a hole of the water piping, the refrigerant piping, the power supply, and the control wiring and unused knockout holes with the putty etc. so as not to infiltrate rain water etc. (field erection work)
- Note 2. At the time of product shipment, the front side piping specification serves as the local drainage connection. When connecting on the rear side, please remove the rear side plug sealing corks, and attach a front side. Ensure there is no leak after the attachment has been fitted.
- Note 3. Take notice of service space as Fig.A. (In case of single installation, 600mm(23-5/8) or more of back space as front space makes easier access when servicing the unit from rear side.)
- Note 4. If water pipes or refrigerant pipes stretch upward, required space for service and maintenance due to replacement of control box is shown in Fig.B.
- Note 5. Environmental condition for installation: -20~40°C(DB) (-4~104°F) as indoor installation.
- Note 6. In case the temperature around the heat source unit has possibility to drop under 0°C(32°F), be careful for the following point to prevent the pipe burst by the water pipe freeze-up.
- Circulate the water all the time even if the heat source unit is not in operation.
 - Drain the water from inside of the heat source unit when the heat source unit will not operate for a long term.
- Note 7. Ensure that the drain piping is downward with a pitch of more than 1/100.
- Note 8. At brazing of pipes, wrap the refrigerant service valve with wet cloth and keep the temperature of refrigerant service valve under 120°C(248°F).

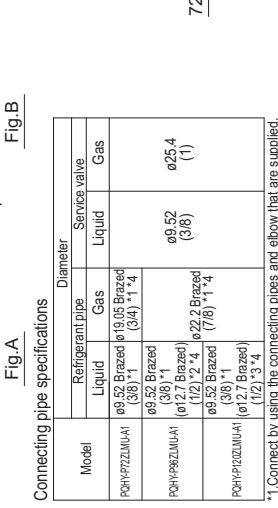
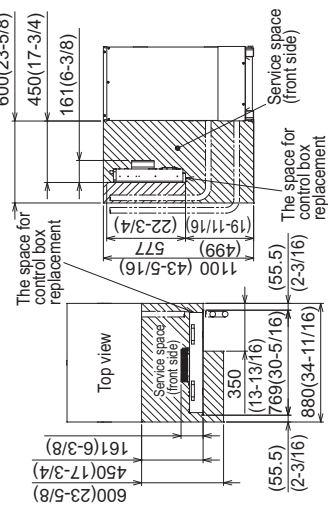

Connecting pipe specifications

Model	Refrigerant pipe		Service valve		Diameter
	Liquid	Gas	Liquid	Gas	
PQHY-P72ZLMU-A1	ø9.52 Brazeed (3/8)" ¹	ø19.05 Brazeed (3/4)" ¹	ø9.52 Brazeed (3/8)" ¹	ø25.4 (1)"	ø25.4 (1)
PQHY-P96ZLMU-A1	ø9.52 Brazeed (3/8)" ¹	ø12.7 Brazeed (1/2)" ²	ø9.52 Brazeed (3/8)" ¹	ø25.4 (1)"	
PQHY-P120ZLMU-A1	ø9.52 Brazeed (3/8)" ¹	ø22.2 Brazeed (7/8)" ¹	ø9.52 Brazeed (3/8)" ¹	ø25.4 (1)"	

¹ Connect by using the connecting pipes and elbow that are supplied.
² Total length is 90mm (3 5/8").
³ Use the pipe joint (field supply) and connect to the refrigerant service valve piping.
⁴ Use the pipe joint (field supply) and connect to the refrigerant service valve piping.

Should this document be altered or changed without MESCA's permission, it becomes null and void. MESCA assumes no responsibility for any consequences in such cases.



for a greener tomorrow

