

Job Name:

Schedule Reference:

Date:



**WATER-SOURCE
VRF HEAT PUMP WITH
HEAT RECOVERY SYSTEM**

ACCESSORIES

- BC Controller MainCMB-P108,1012,1016NU-JA1, CMB-P1016NU-KA1
- BC Controller SubCMB-P104,108NU-KB1
- Joint Adapter (Port Connector > 54,000 Btu/h)..... CMY-R160-J1
- Branch Joint (Downstream capacity ≤72,000 Btu/h)..... CMY-Y102SS-G2
- Branch Joint (Downstream capacity 73,000-96,000 Btu/h)..... CMY-Y102LS-G2
- Branch Joint (145,000 - 234,000 Btu/h) CMY-Y202S-G2
- Branch Joint (Downstream capacity ≤126,000 Btu/h)CMY-R201S-G
- Branch Joint (Downstream capacity 127,000-216,000 Btu/h).....CMY-R202S-G
- Branch Joint (Downstream capacity 217,000-234,000 Btu/h).....CMY-R203S-G
- Branch Joint (Downstream capacity 235,000-360,000 Btu/h)..... CMY-R204S-G
- Reducer (Between ODU and BC)CMY-R302S-G1
- Reducer (Between Main and Sub BC).....CMY-R303S-G1
- Reducer (Between Main and Sub BC).....CMY-R304S-G1
- Reducer (Between Main and Sub BC).....CMY-R305S-G1
- Reducer (Between Main and Sub BC)..... CMY-R306S-G

- Standard Installation (*1) PQRV-P168ZLMU-A1
- Geothermal Installation (*1)(*2)(*3) PQRV-P168ZLMU-A1

Specifications		Model Name
Unit Type		PQRV-P168ZLMU-A1
Nominal Cooling Capacity (575V)	(*1) Btu/h	168,000
Nominal Heating Capacity (575V)	(*1)(*2)(*3) Btu/h	188,000
Operating Temperature Range	Cooling (Indoor)	59~75° F (15~24° C) WB
	Heating (Indoor)	59~81° F (15~27° C) DB
Operating Water Temperature Range	Cooling (*4)	50~113° F (10~45° C)
	Heating (*4)	50~113° F (10~45° C)
External Dimensions (H x W x D)	In. (mm)	57-1/8 x 34-11/16 x 21-11/16 (1450 x 880 x 550)
Net Weight	Lbs. (kg)	510 (231)
External Finish		Galvanized steel sheet
Electrical Power Requirements	Voltage, Phase, Hertz	575V, 3-phase, 60Hz
Minimum Circuit Ampacity (MCA) *	A	16
Maximum Overcurrent Protection (MOP)	A	25
<i>Circulating Water (quality must meet regulations)</i>		
Flow Rate	GPM	31.7
Pressure Drop	psi	6.38
Operation Volume Range	GPM	19.8 - 50.9
Maximum Water Pressure	psi	290
Water-source Connection for Inlet and Outlet	In.	NPT1-1/2 Screw (Install strainer (more than 50 meshes) at water inlet piping of the unit)
Piping Diameter (Brazed) (In. / mm)	High Pressure (Liquid)	7/8 / 22.2
	Low Pressure (Gas)	1-1/8 / 28.58
Max. Total Refrigerant Line Length	Ft.	2,460
Max. Refrigerant Line Length (Between ODU & IDU)	Ft.	541
Max. Control Wiring Length	Ft.	1,640
Indoor Unit	Total Capacity	50~150%
	Model / Quantity	P06~P96/1~42
Sound Pressure Levels	dB(A)	56
Compressor Operating Range		16% - 100%
Compressor Type x Quantity		Inverter scroll hermetic compressor x 1
Refrigerant		R410A x 13 lbs. + 4 oz. (6.0 kg)
Protection Devices	High Pressure	High pressure sensor, High pressure switch at 4.15 MPa (601 psi)
	Inverter Circuit	Over-heat protection, Over-current protection
	Compressor	Over-heat protection
AHRI Ratings (Ducted/Non-Ducted)	EER	11.9 / 13.5
	IEER	18.0 / 21.8
	COP	4.73 / 5.39
	SCHE	19.7 / 19.7

Should this document be altered or changed without MESCA's permission, it becomes null and void. MESCA assumes no responsibility for any consequences in such cases.

NOTES: (*1) <CITY MULTI indoor unit>
Nominal cooling conditions (Test conditions are based on AHRI 1230)
Indoor: 81°FD.B./66°FW.B. (27°CD.B./19°CW.B.),
Water temperature: 86°F (30°C)
Brine concentration 0%

Nominal heating conditions (Test conditions are based on AHRI 1230)
Indoor: 68°FD.B. (20°CD.B.),
Water temperature: 58°F (20°C)
Brine concentration 0%

(*2) <PWFY-P36/72NMU-E-AU>
Nominal cooling conditions
Circulating water Temp. : 86 °F (30 °C)
Pipe length : 25 ft. (7.6 m)
Level difference : 0 ft. (0 m)
Inlet water Temp. : 149 °F (23 °C)
Water flow rate : 1.93 m³/h (8.3 gpm) <P36> / 3.86 m³/h (16.6 gpm) <P72>
Brine concentration : 0 %

(*3) <PWFY-P36NMU-E-BU>
Nominal heating conditions
Circulating water Temp. : 68 °F (20 °C)
Pipe length : 25 ft. (7.6 m)
Level difference : 0 ft. (0 m)
Inlet water Temp. : 149 °F (65 °C)
Water flow rate : 2.15 m³/h (9.2 gpm)
Brine concentration : 0 %

Note: Mitsubishi Electric (MESCA) supports the use of only MESCA supplied and approved accessories for proper functioning of the unit(s). Use of non-MESCA supported accessories will affect warranty coverage.

(*4) If using circulating water temperatures between 23° and 50° F, Dip switch 3-9 must be turned on and glycol (antifreeze) must be added to the water loop to prevent freezing down to 5° F.

Notes:

Specifications are subject to change without notice.

* All electrical work shall comply with National (NEC) and local codes and regulations.

Model: PQR-Y-P168ZLMU-A1 – DIMENSIONS

Unit: mm (in)

- <Accessories>
- Refrigerant (high pressure) conn. pipe 1pc.
(P.144/P.168/P.192 ; Packaged in the accessory kit)
 - Refrigerant (low pressure) conn. pipe 1pc.
(P.144/P.168/P.192 ; Packaged in the accessory kit)
 - Water stopper 1pc.
(P.144/P.168/P.192 ; Packaged in the accessory kit)
 - Sealing material for field piping (high pressure, low pressure) 1pc. each
(P.144/P.168/P.192 ; Packaged in the accessory kit)
 - Sealing material for drain socket 1pc.
(P.144/P.168/P.192 ; Packaged in the accessory kit)
 - Pipe cover for low pressure 1pc.
(P.144/P.168/P.192 ; Packaged in the accessory kit)
 - Sealing material for base leg (two types) 4pcs each
(P.144/P.168/P.192 ; Packaged in the accessory kit)
 - Sealing material for panel 1pc.
(P.144/P.168/P.192 ; Packaged in the accessory kit)

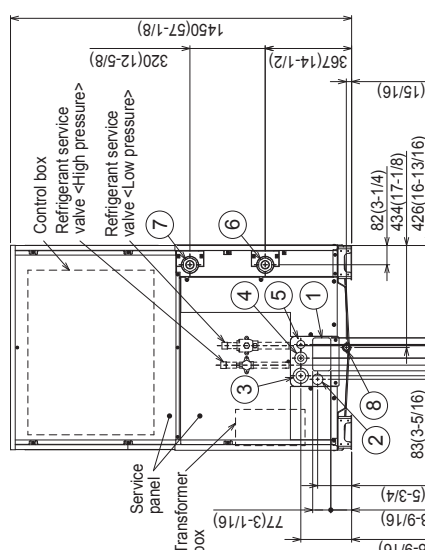
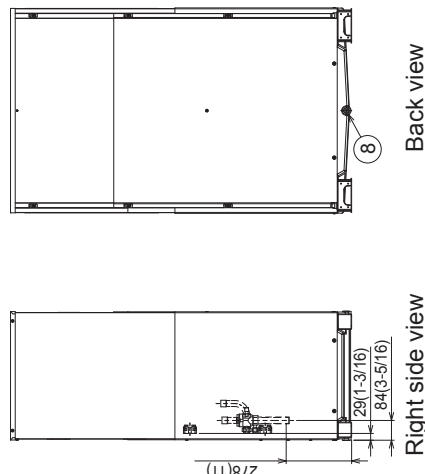
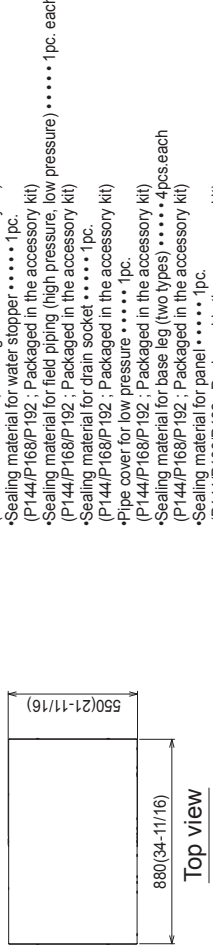

NO	Usage	Specifications
①	Front through hole	140 x 77 Knockout hole (5-9/16) (3-1/16)
②	For pipes	Front through hole (Uses when wining kit (optional parts) is mounted.) ø45 Knockout hole (1-13/16)
③	For wires	Front through hole ø62.7 or ø34.5 Knockout hole (2-1/2) (1-3/8)
④	For transmission cables	Front through hole ø43.7 or ø22.2 Knockout hole (1-3/4) (7/8)
⑤	Water pipe inlet	Front through hole ø34 Knockout hole (1-3/8)
⑥	Water pipe outlet	Front through hole NPT1-1/2 Screw
⑧	Drain pipe	RC3/4 Screw

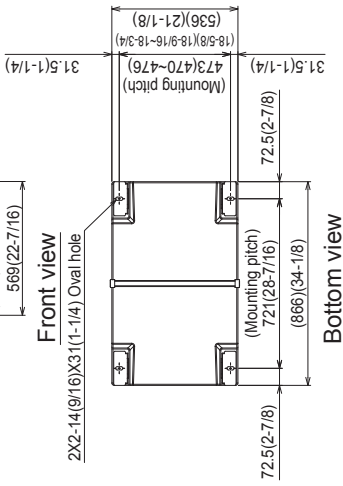

- Note1. Close a hole of the water piping, the refrigerant piping, the power supply, and the control wiring and unused knockout holes with the putty etc. so as not to infiltrate rain water etc.(field erection work)
- Note2. At the time of product shipment, the front side piping specification serves as the local drainage connection. When connecting on the rear side, please remove the rear side plug sealing corks, and attach a front side. Ensure there is no leak after the attachment has been fitted.
- Note3. Take notice of service space as Fig.A. (in case of single installation, 600mm(23-5/8) or more of back space as front side.) makes easier access when servicing the unit from rear side.)
- Note4. If water pipes or refrigerant pipes stretch upward, required space for service and maintenance due to replacement of control box is shown in Fig.B.
- Note5. Environmental condition for installation: -20~40°C(DB)(-4~104 °F) as indoor installation.
- Note6. In case the temperature around the heat source unit has possibility to drop under 0°C(32 °F), be careful for the following point to prevent the pipe burst by the water pipe freeze-up.
- Circulate the water all the time even if the heat source unit is not in operation.
 - Drain the water from inside of the heat source unit when the heat source unit will not operate for a long term.
- Note7. Ensure that the drain piping is downward with a pitch of more than 1/100.
- Note8. At brazing of pipes, wrap the refrigerant refrigerant service valve with wet cloth and keep the temperature of refrigerant service valve under 120°C(248 °F).

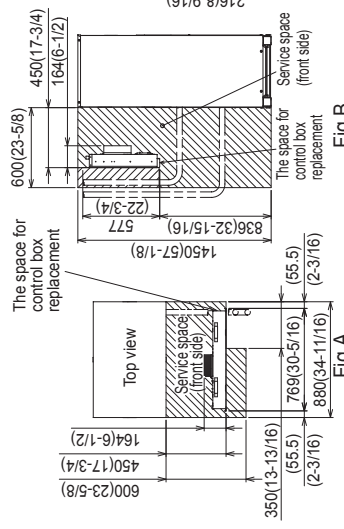

Connecting pipe specifications

Model	Refrigerant pipe	Service valve
PQR-Y-P144ZLMU-A1	High pressure Low pressure	High pressure Low pressure
PQR-Y-P168ZLMU-A1	ø22.2 Brazed (7/8) 1	ø25.4 (1)
PQR-Y-P192ZLMU-A1		ø28.58 Brazed (1-1/8) 1

*1.Connect by using the connecting pipes that are supplied.

Should this document be altered or changed without MESCA's permission, it becomes null and void. MESCA assumes no responsibility for any consequences in such cases.

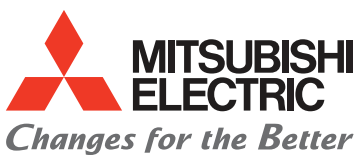

for a greener tomorrow

