

Job Name: _____ Location: _____

Engineer Name: _____ Contractor: _____

System No.: _____ Date: _____

MODULAR WATER-SOURCE VRF HEAT RECOVERY SYSTEM FEATURES

- 3-phase, 575V, 60Hz
- Modular variable refrigerant flow (VRF) systems; smaller capacity units can be piped together to form a single, large-capacity two-pipe system
- Designed for closed water loops; water quality must meet regulations
- Self-cooling cabinet design
- Compact size for each water-source module
- Max. Total Refrigerant Piping Length: 1,804' (P72,96,120), 2,461' (P144,168,192,216,240); Max. Refrigerant Line Length: 541'; Max. Control Wiring Length: 1,640'
- Connects to CITY MULTI indoor units; controlled via CITY MULTI Controls Network (CMCN)
- External finish: Galvanized Steel Sheets
- Operating Indoor Temperature Range
Cooling: 59° ~ 75°F (15° ~ 24°C) WB
Heating: 59° ~ 81°F (15° ~ 27°C) DB
- Operating Water Temperature Range
Cooling: 50° ~ 113°F (10° ~ 45°C)
Heating: 50° ~ 95°F (10° ~ 35°C)



PQRYP96ZKMU-A PQRYP72ZKMU-A

OPTIONAL PARTS

- Twinning Kit*.....CMYZ100CBK
 - Branch Joint (T-Branch: ≤ 72,000 Btu/h).....CMY-Y102SS-G2
 - Branch Joint (T-Branch: 73,000 - 144,000 Btu/h)....CMY-Y102LS-G2
 - Branch Joint (T-Branch: 145,000 - 240,000 Btu/h)....CMY-Y202S-G2
 - Branch Joint (T-Branch: ≥ 241,000.....CMY-Y302S-G2
 - Joint Adapter (Port Connector: > 54,000 Btu/h).....CMY-R160C-J
 - Main BC Controller.....CMB-P108/1010/1013/1016NU-GA/NU-HA
 - Sub BC Controller.....CMB-P104/108NU-GB/P1016NU-HB
- * Twinning Kit is necessary to combine the refrigerant flow of the modules and is sold separately.

Specifications		System	Module 1	Module 2
Unit Type		PQRYP168ZSKMU-A	PQRYP96ZKMU-A	PQRYP72ZKMU-A
Nominal Cooling Capacity	Btu/h	168,000	96,000	72,000
Nominal Heating Capacity	Btu/h	188,000	108,000	80,000
External Dimensions (H x W x D)	In. / mm	Refer to Module Data	43-5/16 x 34-11/16 x 21-11/16 / 1,100 x 880 x 550	43-5/16 x 34-11/16 x 21-11/16 / 1,100 x 880 x 550
Net Weight	Lbs. / kg	808 / 366	404 / 183	404 / 183
Electrical Power Requirements	Voltage, Phase, Hertz	575V, 3-phase, 60Hz	575V, 3-phase, 60Hz	575V, 3-phase, 60Hz
Cooling Power Input	kW	10.67	5.93	3.75
Heating Power Input	kW	10.19	6.17	3.93
Cooling Current (575V)	A	11.9	6.6	4.1
Heating Current (575V)	A	11.3	6.8	4.3
Minimum Circuit Amp. (MCA)** (*)	A	Refer to Module Data**	11**	9**
Maximum Circuit Breaker Size**	A	Refer to Module Data**	15**	15**
Circulating Water (quality must meet regulations)				
Flow Rate	GPM	Refer to Module Data**	25.4	25.4
Pressure Drop	psi	Refer to Module Data**	3.48	3.48
Operation Volume Range	GPM	Refer to Module Data**	20 - 32	20 - 32
Maximum Water Pressure	MPa / psi	Refer to Module Data**	2 / 290	2 / 290
Water-source Connections (Each for Inlet and Outlet)	In.	Refer to Module Data**	Rc1-1/2 Screw (Install strainer (more than 50 meshes) at water inlet piping of the unit)	
Piping Diameter				
From Twinning Kit to Indoor Units (Braze) (In. / mm)	Liquid (High Pressure)	7/8 / 22.2	Refer to System Data	
	Gas (Low Pressure)	1-1/8 / 28.58		
From Modules to Twinning Kit (Braze) (In. / mm)	Liquid (High Pressure)	Refer to Module Data	3/4 / 19.05	3/4 / 19.05
	Gas (Low Pressure)	Refer to Module Data	7/8 / 22.2	-
Indoor Unit	Total Capacity	50 to 150% of WSUs	Refer to System Data	
	Model / Quantity	P06 ~ P96 / 1 to 42		
Sound Pressure Level	dB(A)	50	48	46
Compressor Operating Range		Cooling:10-100%, Heating:11-100%	Refer to System Data	
Compressor Type x Quantity			Inverter-driven Scroll Hermetic x 1	Inverter-driven Scroll Hermetic x 1
Compressor Motor Output	kW	Refer to Module Data	6	4.3
Compressor Crankcase Heater	kW		-	-
Refrigerant		Refer to Module Data	R410A	
Lubricant			MEL32	
High-pressure Protection Device			601 psi / 4.15 MPa	601 psi / 4.15 MPa
Compressor / Fan Protection Device		Refer to Module Data	Overheat Protection	Overheat Protection
Inverter Protection Device			Overheat / Overcurrent Protection	Overheat / Overcurrent Protection

** Each individual module requires a separate electrical connection. Reference electrical data for each individual module.

* All electrical work shall comply with National (CEC) and local codes and regulations.

Should this document be altered or changed without MIESCA's permission, it becomes null and void. MIESCA assumes no responsibility for any consequences in such cases.

Outdoor Unit: PQRYP168ZSKMU-A – DIMENSIONS

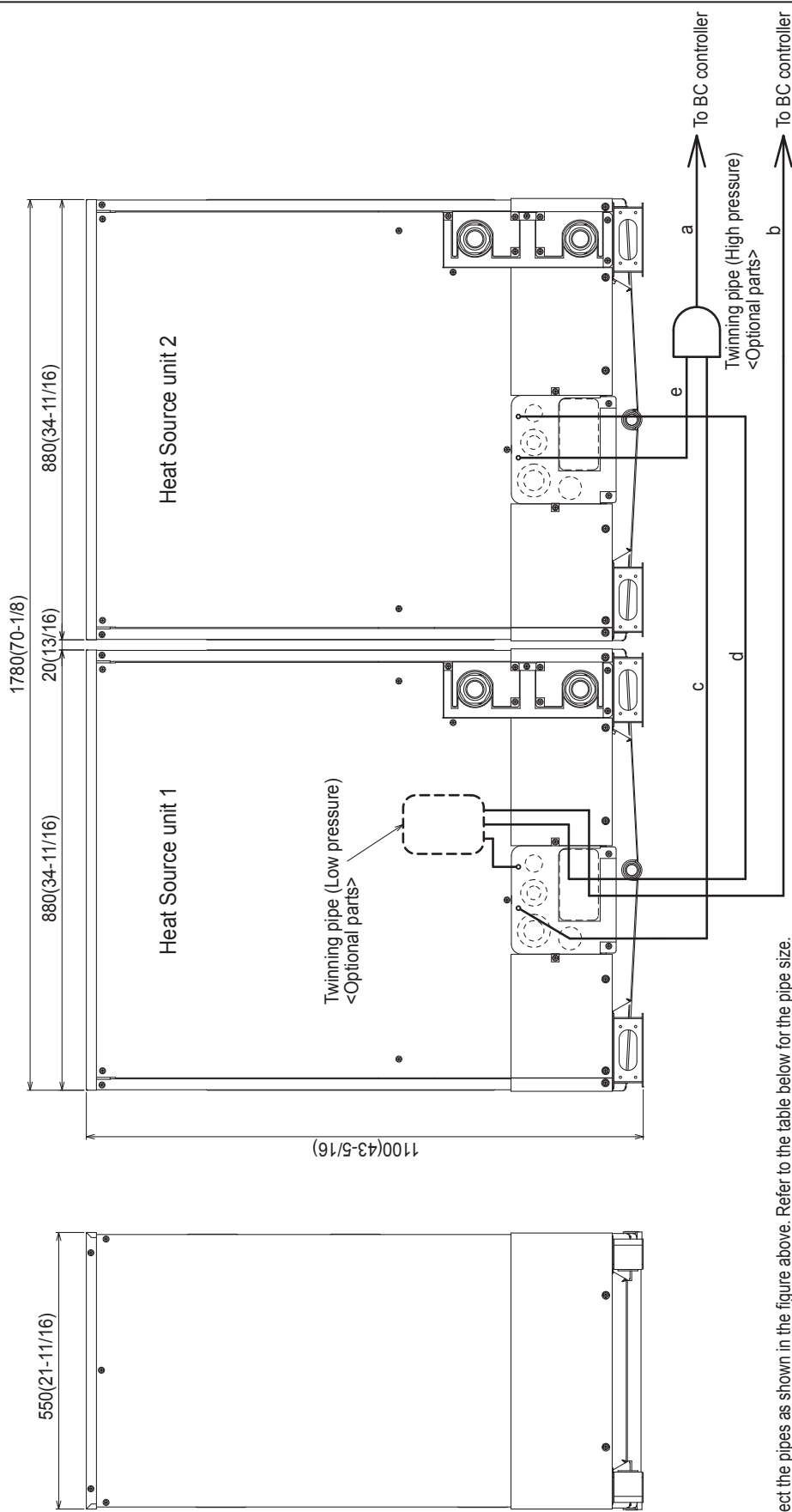

Unit : mm(in)

- Note 1. Connect the pipes as shown in the figure above. Refer to the table below for the pipe size.
 2. Twinning pipe (High pressure) should not be tilted more than 15 degrees from the horizontal plane.
 3. See the Installation Manual for the details of Twinning pipe installation.
 4. Only use the Twinning pipe by Mitsubishi (optional parts).

Twinning pipe connection size

Package unit name	PQRY-P144ZSKMU-A	PQRY-P168ZSKMU-A	PQRY-P192ZSKMU-A	PQRY-P216ZSKMU-A	PQRY-P240ZSKMU-A
Heat Source unit 1	PQRY-P72ZKMU-A	PQRY-P96ZKMU-A	PQRY-P120ZKMU-A	PQRY-P120ZKMU-A	PQRY-P120ZKMU-A
Heat Source unit 2	PQRY-P72ZKMU-A	PQRY-P96ZKMU-A	PQRY-P120ZKMU-A	PQRY-P120ZKMU-A	PQRY-P120ZKMU-A
Twinning pipe Kit(optional parts)	CMY-Z100CBK				
BC controller~ Twinning pipe	High pressure	Low pressure	a	b	
			ø22.2(7/8)	ø28.58(1-1/8)	ø28.58(1-1/8)

Unit model	High pressure	Low pressure
	c or e	d
P72	ø19.05(3/4)	ø22.2(7/8)
P96	ø19.05(3/4)	ø22.2(7/8)
P120	ø19.05(3/4)	ø22.2(7/8)

Should this document be altered or changed without MESCA's permission, it becomes null and void. MESCA assumes no responsibility for any consequences in such cases.

Twinning Kit: CMY-Z100C BK

CMY-Z100CBK

Low-pressure pipe twinning kit

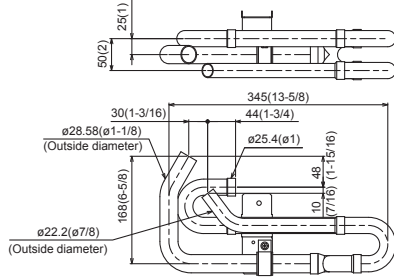

<Elbow pipe (Accessory)>

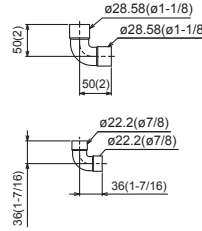

<Pipe for routing through the front (Accessory)>

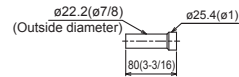

High-pressure twinning pipe

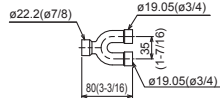

<Deformed pipe (Accessory)>

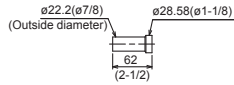

<Pipe for routing through the front (Accessory)>

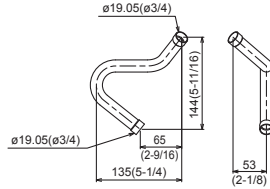

Should this document be altered or changed without MESCA's permission, it becomes null and void. MESCA assumes no responsibility for any consequences in such cases.

Modules 1 and 2: PQRY-P96ZKMU-A & PQRY-P72ZKMU-A – DIMENSIONS

Unit : mm(in)

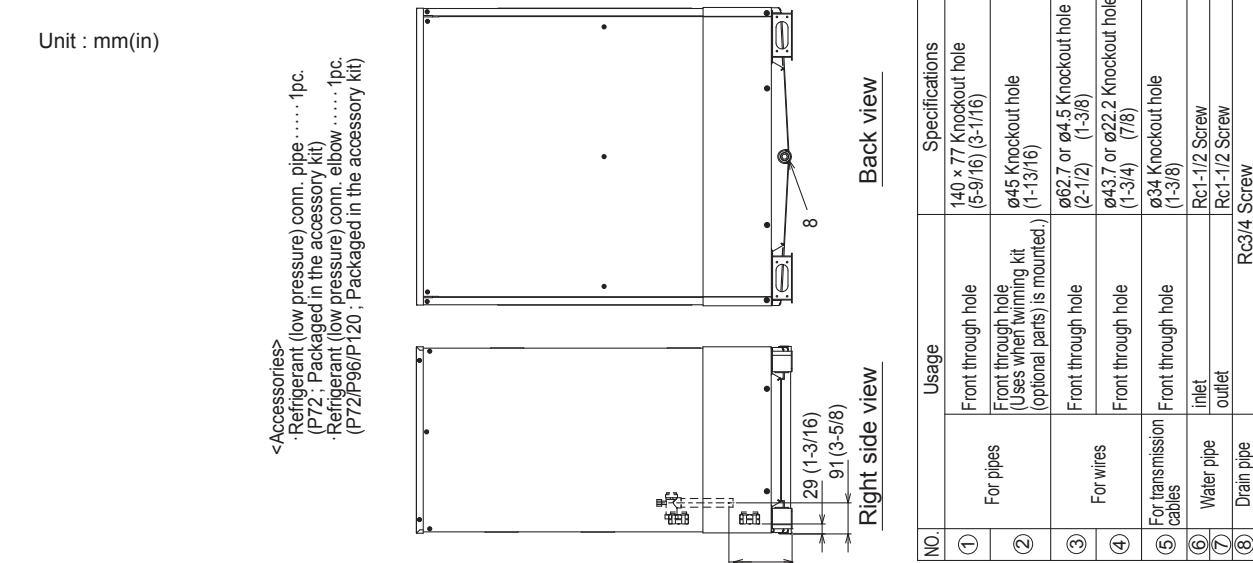

<Accessories>
 · Refrigerant (low pressure) conn. pipe 1pc.
 (P72 : Packaged in the accessory kit)
 · Refrigerant (low pressure) conn. elbow 1pc.
 (P72/P96/P120 : Packaged in the accessory kit)

NO.	Usage	Specifications
①	Front through hole	140 x 77 Knockout hole (5-9/16) (3-1/16)
②	Front through hole (Uses when trimming kit (optional parts) is mounted.)	ø45 Knockout hole (1-13/16)
③	Front through hole	ø62.7 or ø4.5 Knockout hole (2-1/2) (1-3/8)
④	Front through hole	ø43.7 or ø22.2 Knockout hole (1-3/4) (7/8)
⑤	Front through hole	ø34 Knockout hole (1-3/8)
⑥	Water pipe inlet	Rc1-1/2 Screw
⑦	Water pipe outlet	Rc1-1/2 Screw
⑧	Drain pipe	Rc3/4 Screw

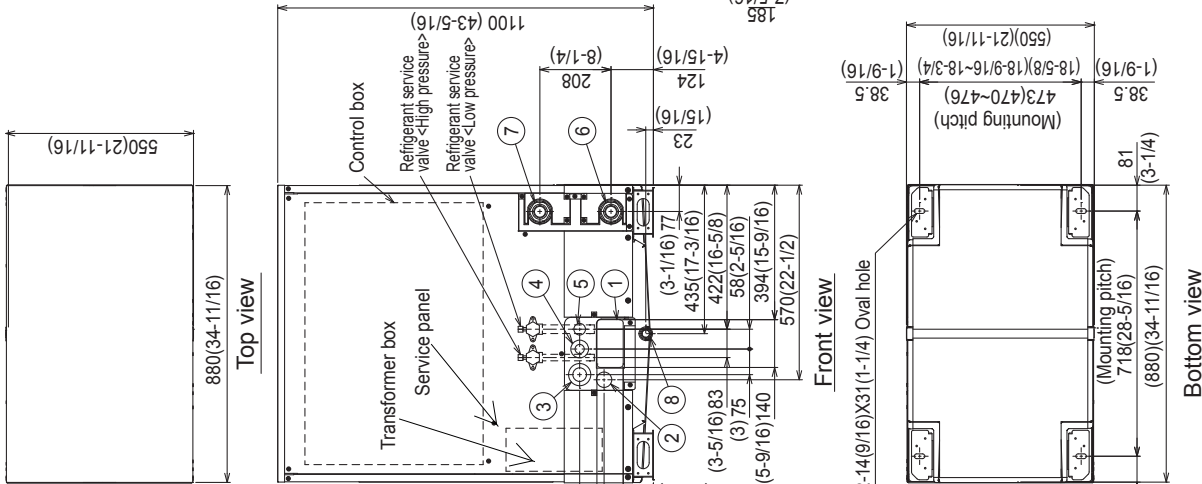

Fig. B

Fig. A

Note1. Close a hole of the water piping, the refrigerant piping, the power supply, and the control wiring and unused knockout holes with the putty etc. so as not to infiltrate rain water etc. (field erection work)
 Note2. At the time of product shipment, the front side piping specification serves as the local drainage connection. When connecting on the rear side, please remove the rear side plug sealing corks, and attach a front side. Ensure there is no leak after the attachment has been fitted.
 Note3. Take notice of service space as Fig.A. (In case of single

makes easier access when servicing the unit from rear side.)
 Note4. If water pipes or refrigerant pipes stretch upward, required space for service and maintenance due to replacement of control box is shown in Fig.B.

as indoor installation.

Note6. In case the temperature around the heat source unit has possibility to drop under 0°C(32°F), be careful for the following point to prevent the pipe burst by the water pipe freeze-up.
 · Circulate the water all the time even if the heat source unit is not in operation.

Note7. Ensure that the drain piping is downward with a pitch of more than 1/100.
 Note8. At brazing of pipes, wrap the refrigerant service valve with wet cloth and keep the temperature of refrigerant service valve under 120°C(248°F).

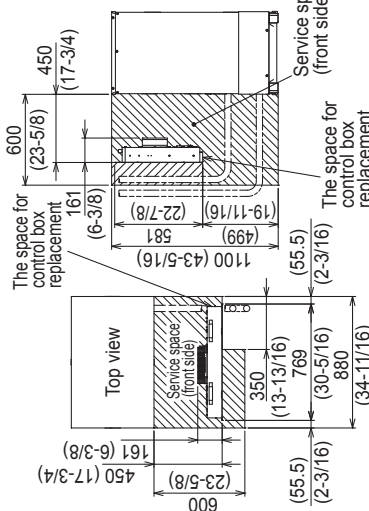

Connecting pipe specifications

Model	Connection specifications for the refrigerant service valve
PQRY-P72ZKMU-A	High pressure ø15.88 Brazed (5/8) Low pressure ø19.05 Brazed *1 (3/4)
PQRY-P96ZKMU-A	High pressure ø19.05 Brazed (3/4) Low pressure ø22.2 Brazed *1 (7/8)

*1. Connect by using the connecting pipes and elbow that are supplied.



CONFORMS TO
 ANSI/UL STD. 1995
 CERTIFIED TO
 CAN/CSA STD.
 C22. 2 NO. 236



Mitsubishi Electric Sales Canada Inc.
 www.MitsubishiElectric.ca

Specifications are subject to change without notice.

PR_SB_PQRY-P168ZSKMU-A_201710

Should this document be altered or changed without MESCA's permission, it becomes null and void. MESCA assumes no responsibility for any consequences in such cases.