

Job Name:

Schedule Reference:

Date:



OUTDOOR VRF HEAT PUMP SYSTEM

### ACCESSORIES

- Twinning Kit ... (Required - sold separately) ..... CMY-Y100CBK3
- T-Branch Joint (≤ 72,000 Btu/h) ..... CMY-Y102SS-G2
- T-Branch Joint (73,000 - 144,000 Btu/h) ..... CMY-Y102LS-G2
- T-Branch Joint (145,000 - 234,000 Btu/h) ..... CMY-Y202S-G2
- T-Branch Joint (≥ 235,000 Btu/h) ..... CMY-Y302S-G2
- Header - 4 Branch (Capacity: ≤ 72,000 Btu/h) ..... CMY-Y104C-G
- Header - 8 Branch (Capacity: ≤ 144,000 Btu/h) ..... CMY-Y108C-G
- Header - 10 Branch (Capacity: ≤ 234,000 Btu/h) ..... CMY-Y1010C-G

### UNIT OPTION

- Standard Model.....PUHY-P216ZSKMU-A
- Seacoast (BS) Model.....PUHY-P216ZSKMU-A-BS

**\* All electrical work shall comply with National (CEC) and local codes and regulations.**

Specifications		System	Module 1	Module 2
Unit Type		PUHY-P216ZSKMU-A (-BS)	PUHY-P120ZKMU-A (-BS)	PUHY-P96ZKMU-A (-BS)
Nominal Cooling Capacity (575V)	Btu/h	216,000	120,000	96,000
Nominal Heating Capacity (575V)	Btu/h	243,000	135,000	108,000
Operating Temperature Range	Cooling (Outdoor)	Refer to Module Data	23~115°F (-5~46°C) DB	
	Heating (Outdoor)		-4~60°F (-20~15.5°C) WB	
External Dimensions (H x W x D)	In. (mm)	Refer to Module Data	64-31/32 x 68-29/32 x 29-5/32 (1,650 x 1,750 x 740)	64-31/32 x 48-1/16 x 29-5/32 (1,650 x 1,220 x 740)
Net Weight	Lbs. (kg)	1,313 (595)	757 (343)	556 (252)
External Finish - Colour (+ power coating for - BS type)		Refer to Module Data	Pre-coated galvanized steel sheet - MUNSELL 5Y 8/1 or similar	
Electrical Power Requirements	Voltage, Phase, Hertz	Refer to Module Data**	575V, 3-Phase, 60Hz	
Minimum Circuit Ampacity (MCA) *	A	Refer to Module Data**	19	15
Maximum Overcurrent Protection (MOP)	A	Refer to Module Data**	30	20
<b>Piping Diameter (Brazed)</b>				
From Twinning Kit to First Joint or Header (In. / mm)	Liquid (High Pressure)	5/8 (15.88)	Refer to System Data	
	Gas (Low Pressure)	1-1/8 (28.58)		
Max. Total Refrigerant Line Length	Ft.	3,280	Refer to System Data	
Max. Refrigerant Line Length (Between ODU & IDU)	Ft.	541		
Max. Control Wiring Length	Ft.	1,640		
Indoor Unit	Total Capacity	50~130% of outdoor unit capacity	Refer to System Data	
	Model / Quantity	P06~P96/2~46	Refer to System Data	
Sound Pressure Level	dB(A)	62.5	Refer to System Data	
<b>Fan</b>				
Type x Quantity		Refer to Module Data	Propeller fan x 2	Propeller fan x 1
Airflow Rate	CFM		10,950	6,700
External Static Pressure	In. WG	Refer to Module Data	Selectable; 0, 0.12 or 0.24" WG; factory set to 0"W.G.	
Compressor Operating Range		5% to 100%	Refer to System Data	
Compressor Type x Quantity		Refer to Module Data	Inverter-driven Scroll Hermetic x 1	Inverter-driven Scroll Hermetic x 1
Refrigerant		Refer to Module Data	R410A x 26 lbs + 1 oz (11.8 kg)	R410A x 25 lbs + 6 oz (11.5 kg)
Protection Devices	High Pressure	Refer to Module Data	High pressure sensor, High pressure switch at 4.15 MPa (601 psi)	High pressure sensor, High pressure switch at 4.15 MPa (601 psi)
	Inverter Circuit (Comp. / Fan)		Over-current protection	Over-current protection
AHRI Ratings (Ducted/Non-Ducted)	EER	11.8/12.7	Refer to System Data	
	IEER	20.7/23.2		
	COP @47F - COP @17F	3.51/3.56 - 2.48/2.09		
<b>Heat Exchanger</b>		<b>Refer to Module Data</b>	<b>Salt resistant cross fin &amp; copper tube</b>	<b>Salt resistant cross fin &amp; copper tube</b>

**Note: Mitsubishi Electric (MESCA) supports the use of only MESCA supplied and approved Snow Guard / Wind Deflectors / Windscreens and accessories for proper functioning of the unit(s). Use of non-MESCA supported Snow Guard / Wind Deflectors / Windscreens and accessories will affect warranty coverage.**

\*\* Each individual module requires a separate electrical connection. Reference electrical data for each individual module.



# Module: PUHY-P216ZSKMU-A (-BS) - DIMENSIONS

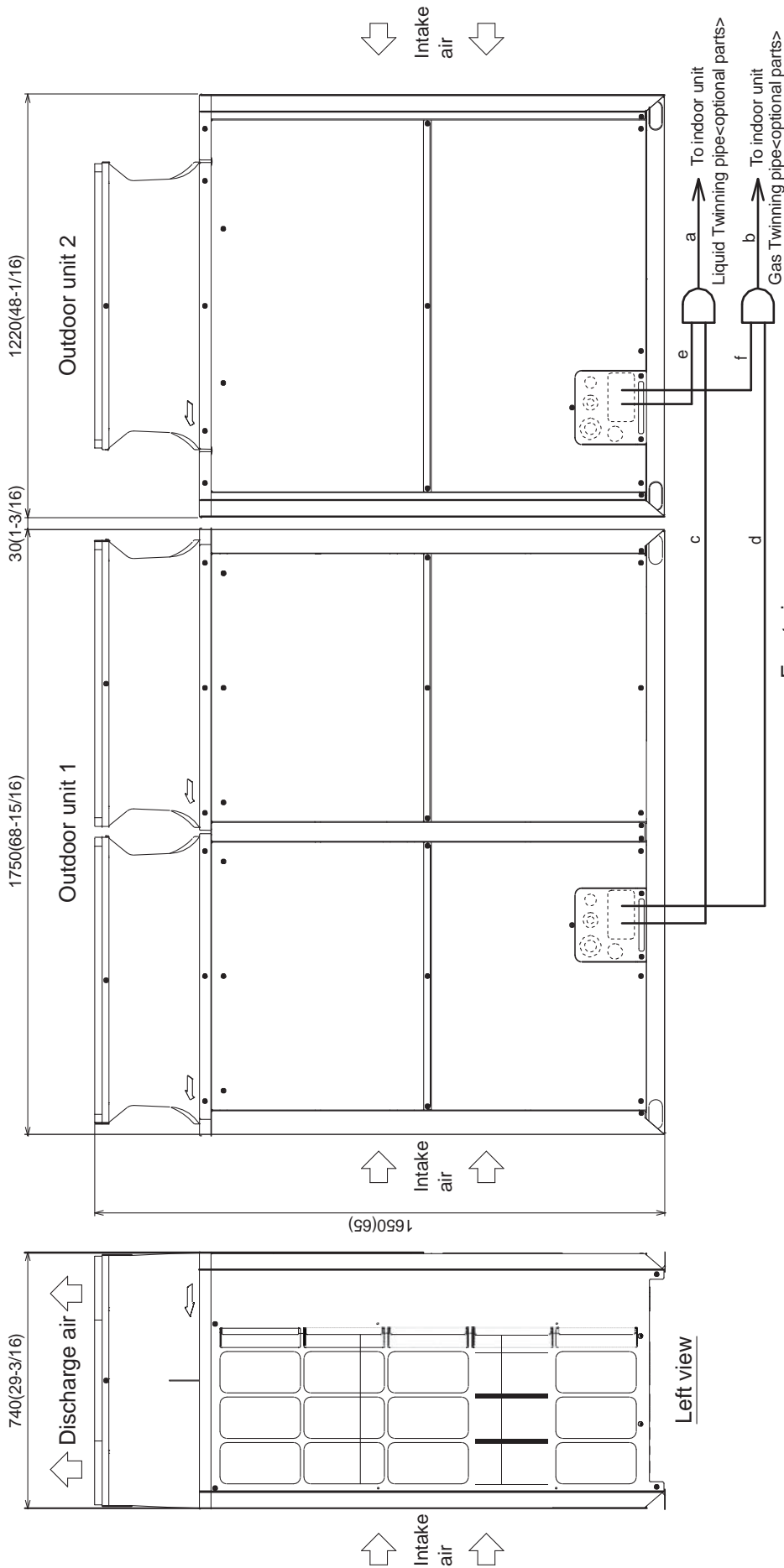

Unit : mm (in.)

Front view

Left view

Twinning pipe connection size

Package unit name	PUHY-P216ZSKMU-A(-BS)	
Outdoor unit 1	PUHY-P120ZKMU-A(-BS)	
Outdoor unit 2	PUHY-P96ZKMU-A(-BS)	
Outdoor Twinning Kit(optional parts)	CMY-Y100CBK3	
Indoor unit- Twinning pipe	Liquid a	ø15.88(5/8)
	Gas b	ø28.58(1-1/8)

Unit model	Liquid c or e	Gas d or f
P96	ø9.52(3/8)	ø22.2(7/8)
P120	ø12.7(1/2)	ø28.58(1-1/8)

- Note 1. Connect the pipes as shown in the figure above. Refer to the table above for the pipe size.  
 2. Twinning pipes should not be tilted more than 15 degrees from the horizontal plane.  
 Be sure to see the Installation Manual for details of Twinning pipe installation.  
 3. The pipe section before the Twinning pipe (sections "a" and "b" in the figure) must have at least 500mm(19-1/16) of straight section (\*including the straight pipe that is supplied with the Twinning pipe).  
 4. Only use the Twinning pipe by Mitsubishi (optional parts).

# Modules: 1 : PUHY-P96ZKMU-A (-BS) - DIMENSIONS

Unit : mm (in.)

Note 1. Please refer to the next page for information regarding necessary spacing around the unit and foundation work.  
 2. At brazing of pipes, wrap the refrigerant service valve with wet cloth and keep the temperature of refrigerant service valve under 120°C(248°F).

Connecting pipe specifications

Model	Refrigerant pipe		Service valve	
	Liquid	Gas	Liquid	Gas
PUHY-P96ZKMU	ø9.52 Braze (3/8) *1 (ø12.7 Braze) (1/2) *2 *3	ø22.2 Braze (7/8) *2	ø9.52 (3/8)	ø28.58 (1-1/8)

\*1 Expand the on-site piping and connect to the refrigerant service valve piping.  
 \*2 Use the pipe joint(field supply) and connect to the refrigerant service valve piping.  
 \*3 Furthest piping length (OU from IU) ≥ 90m(295ft)

NO.	Usage	Specifications
①	For pipes Front through hole	140 x 77 Knockout hole (5-9/16) (3-1/16)
②	Bottom through hole	150 x 94 Knockout hole (5-15/16) (3-3/4)
③	For wires Front through hole	ø62.7 or ø34.5 Knockout hole (2-1/2) (1-3/8)
④	Front through hole	ø43.7 or ø22.2 Knockout hole (1-3/4) (7/8)
⑤	Bottom through hole	ø65 Knockout hole (2-9/16)
⑥	Bottom through hole	ø52 Knockout hole (2-1/16)
⑦	For transmission cables Front through hole	ø34 Knockout hole (1-3/8)

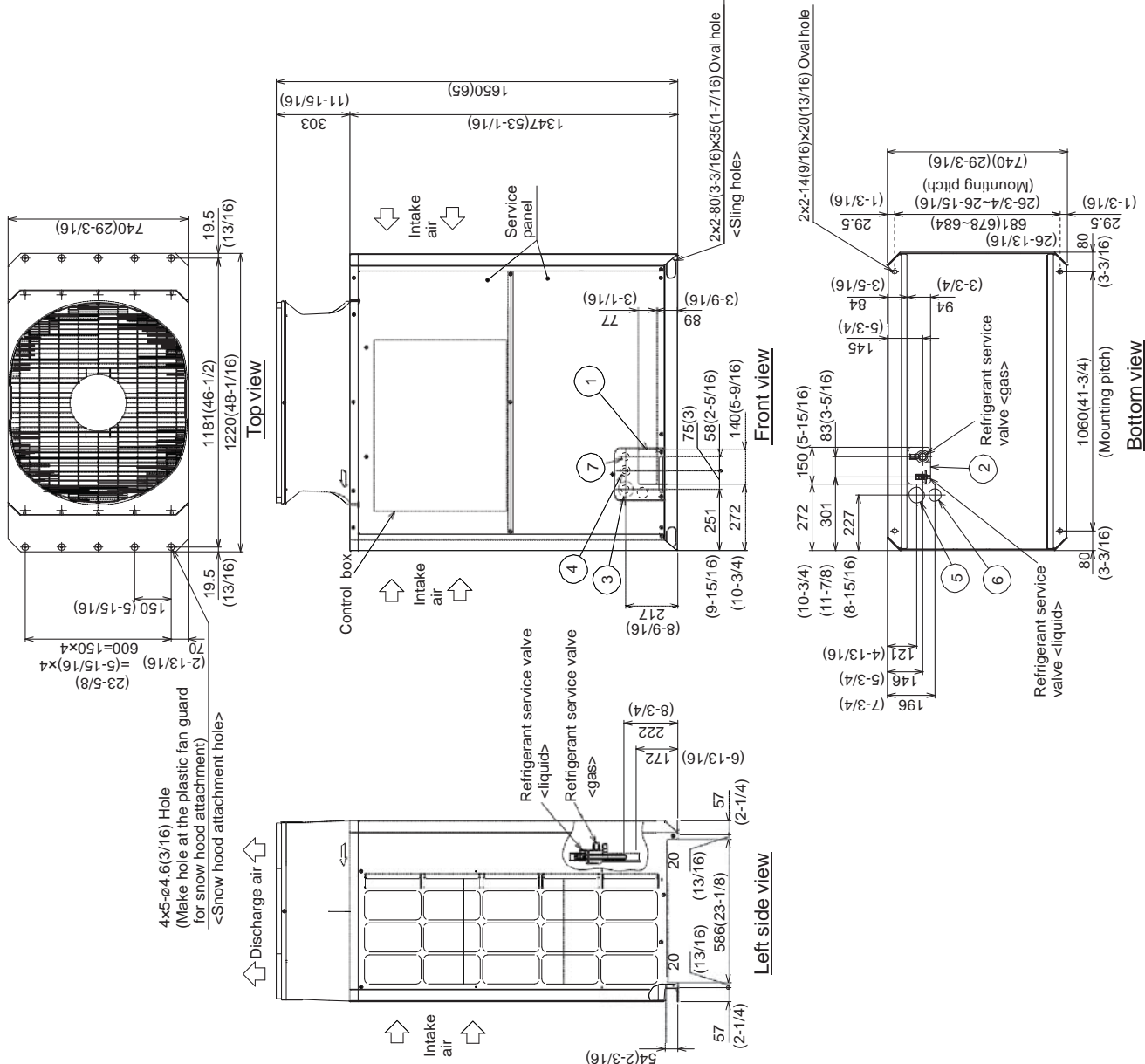

Specifications are subject to change without notice.

Should this document be altered or changed without MESCA's permission, it becomes null and void. MESCA assumes no responsibility for any consequences in such cases.

# Modules: 2 : PUHY-P120ZKMU-A (-BS) - DIMENSIONS

Unit : mm (in.)

Should this document be altered or changed without MESCA's permission, it becomes null and void. MESCA assumes no responsibility for any consequences in such cases.

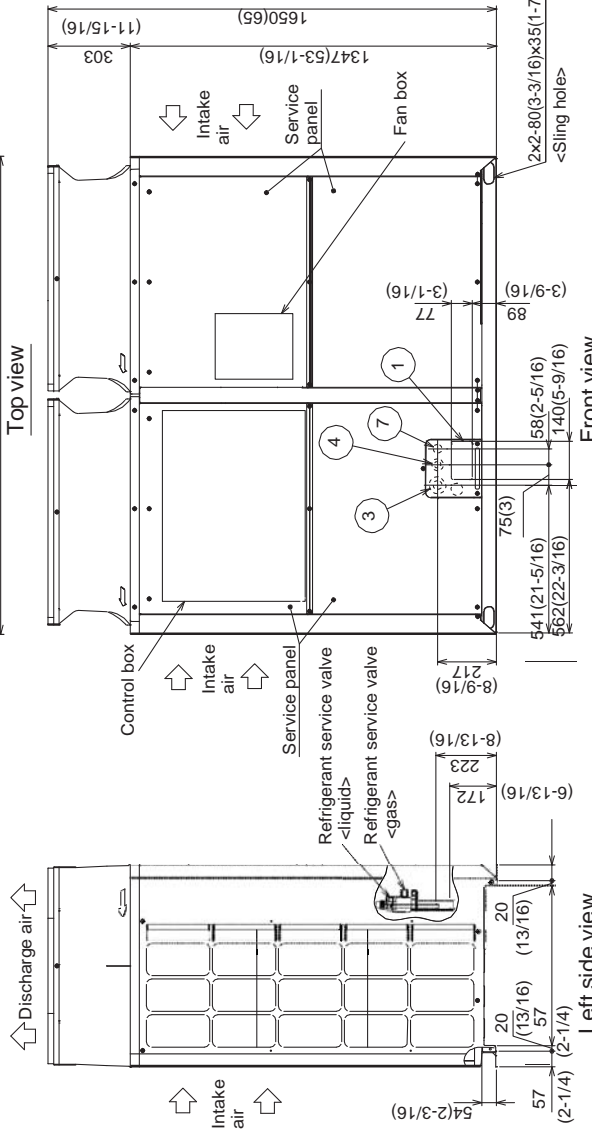
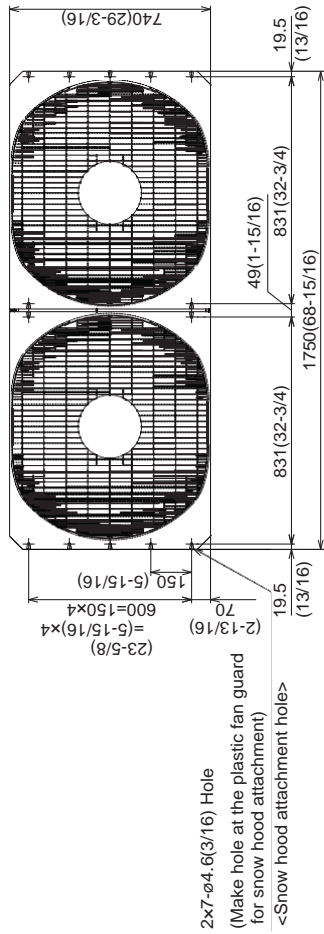

Note 1. Please refer to the next page for information regarding necessary spacing around the unit and foundation work.  
2. At brazing of pipes, wrap the refrigerant service valve with wet cloth and keep the temperature of refrigerant service valve under 120°C(248 °F).

Connecting pipe specifications

Model	Diameter			
	Refrigerant pipe		Service valve	
	Liquid	Gas	Liquid	Gas
PUHY-P120ZKMU	ø9.52 Brazed (3/8)*2 ø12.7 Brazed (1/2)*1 *3 *4	ø28.58 Brazed (1-1/8)*1	ø12.7 (1/2)	ø28.58 (1-1/8)
PUHY-P144ZKMU	ø12.7 Brazed (1/2)*1			
PUHY-P168ZSKMU	ø15.88 Brazed (5/8)*2			

- \*1 Expand the on-site piping and connect to the refrigerant service valve piping.
- \*2 Use the pipe joint(field supply) and connect to the refrigerant service valve piping.
- \*3 Indicates dimensions and connection specifications in the case the unit is used in combination with other outdoor units.
- \*4 Furthest piping length (OU from IU)≥40m(131ft)

NO.	Usage	Specifications
①	For pipes	Frontthrough hole 140 x 77 Knockout hole (5-9/16) (3-1/16)
②		Bottomthrough hole 150 x 94 Knockout hole (5-15/16)(3-3/4)
③		Frontthrough hole ø62.7 or ø34.5 Knockout hole (2-1/2) (1-3/8)
④		Frontthrough hole ø43.7 or ø22.2 Knockout hole (1-3/4) (7/8)
⑤	For wires	Bottomthrough hole ø65 Knockout hole (2-9/16)
⑥		Bottomthrough hole ø52 Knockout hole (2-1/16)
⑦	For transmission cables	Frontthrough hole ø34 Knockout hole (1-3/8)

# Twinning Kit: CMY-Y100CBK3

## CMY-Y100CBK3

For Gas pipe:

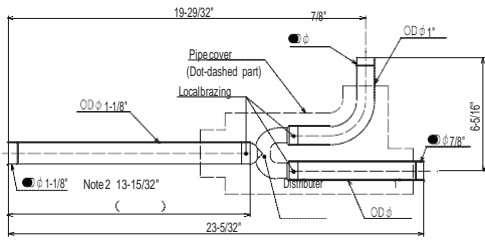

For Liquid pipe:

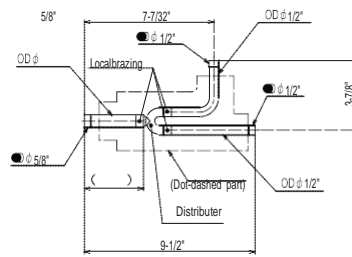

<Reducer(Accessory)>

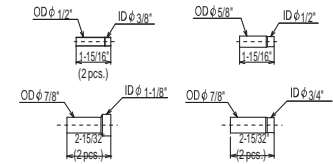

in.

ID: Inner Diameter OD: Outer Diameter

Note 1. Reference the attitude angle of the branch pipe below the fig.

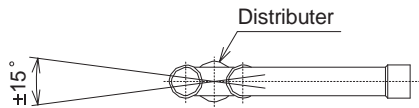

The angle of the branch pipe for high pressure is within  $\pm 5^\circ$  against the horizontal plane.

2. Use the attached pipe to braze the port-opening of the distributor.
3. Pipe diameter is indicated by inside diameter.
4. Only use the Twinning pipe by Mitsubishi (optional parts) .

## Notes:

Should this document be altered or changed without MESCA's permission, it becomes null and void. MESCA assumes no responsibility for any consequences in such cases.



for a greener tomorrow

