

SPLIT-TYPE AIR CONDITIONERS

**Revision B:**

- MUZ-GS09/12/15/18/24NA - [U1],  
 MUZ-GS09/12/15/18/24NAH - [U1],  
 MUZ-GS09/12/15/18/24NAHZ - [U1],  
 MUY-GS09/12/15/18/24NA - [U1],  
 MUZ-GS30/36NA2 - [U1], MUZ-GS30/36NAH2 - [U1]  
 and MUY-GS30/36NA2 - [U1] have been added.  
 OBH875 REVISED EDITION-A is void.

# OUTDOOR UNIT

# SERVICE MANUAL

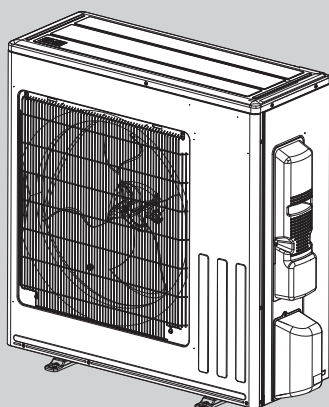


**No. OBH875  
 REVISED EDITION-B**

**Models**

- |                    |                     |                    |
|--------------------|---------------------|--------------------|
| MUZ-GS09NA - [U1]  | MUZ-GS18NAH - [U1]  | MUY-GS09NA - [U1]  |
| MUZ-GS12NA - [U1]  | MUZ-GS24NAH - [U1]  | MUY-GS12NA - [U1]  |
| MUZ-GS15NA - [U1]  | MUZ-GS30NAH - [U1]  | MUY-GS15NA - [U1]  |
| MUZ-GS18NA - [U1]  | MUZ-GS30NAH2 - [U1] | MUY-GS18NA - [U1]  |
| MUZ-GS24NA - [U1]  | MUZ-GS36NAH - [U1]  | MUY-GS24NA - [U1]  |
| MUZ-GS30NA - [U1]  | MUZ-GS36NAH2 - [U1] | MUY-GS30NA - [U1]  |
| MUZ-GS30NA2 - [U1] | MUZ-GS09NAHZ - [U1] | MUY-GS30NA2 - [U1] |
| MUZ-GS36NA - [U1]  | MUZ-GS12NAHZ - [U1] | MUY-GS36NA - [U1]  |
| MUZ-GS36NA2 - [U1] | MUZ-GS15NAHZ - [U1] | MUY-GS36NA2 - [U1] |
| MUZ-GS09NAH - [U1] | MUZ-GS18NAHZ - [U1] |                    |
| MUZ-GS12NAH - [U1] | MUZ-GS24NAHZ - [U1] |                    |
| MUZ-GS15NAH - [U1] |                     |                    |

Indoor unit service manual  
 MSZ-GS•NA, MSY-GS•NA Series (OBH874)



- |                     |                      |
|---------------------|----------------------|
| MUZ-GS18/24/30/36NA | MUZ-GS18/24/30/36NAH |
| MUZ-GS18/24NAHZ     | MUY-GS18/24/30/36NA  |
| MUZ-GS30/36NA2      | MUZ-GS30/36NAH2      |
| MUY-GS30/36NA2      |                      |

**CONTENTS**

1. TECHNICAL CHANGES .....	2
2. PART NAMES AND FUNCTIONS .....	3
3. SPECIFICATION .....	4
4. OUTLINES AND DIMENSIONS .....	10
5. WIRING DIAGRAM .....	12
6. REFRIGERANT SYSTEM DIAGRAM .....	21
7. DATA.....	26
8. ACTUATOR CONTROL .....	57
9. SERVICE FUNCTIONS.....	58
10. TROUBLESHOOTING .....	59
11. DISASSEMBLY INSTRUCTIONS.....	87

**PARTS CATALOG (OBB875)**

# Use the specified refrigerant only

## Never use any refrigerant other than that specified.

Doing so may cause a burst, an explosion, or fire when the unit is being used, serviced, or disposed of.

Correct refrigerant is specified in the manuals and on the spec labels provided with our products.

We will not be held responsible for mechanical failure, system malfunction, unit breakdown or accidents caused by failure to follow the instructions.

### <Preparation before the repair service>

- Prepare the proper tools.
- Prepare the proper protectors.
- Provide adequate ventilation.
- After stopping the operation of the air conditioner, turn off the power-supply breaker and pull the power plug.
- Discharge the capacitor before the work involving the electric parts.

### <Precautions during the repair service>

- Do not perform the work involving the electric parts with wet hands.
- Do not pour water into the electric parts.
- Do not touch the refrigerant.
- Do not touch the hot or cold areas in the refrigeration cycle.
- When the repair or the inspection of the circuit needs to be done without turning off the power, exercise great caution not to touch the live parts.

## ⚠ WARNING

- When the refrigeration circuit has a leak, do not execute pump down with the compressor.
- When pumping down the refrigerant, stop the compressor before disconnecting the refrigerant pipes. The compressor may burst if air etc. get into it.
- When opening or closing the valve below freezing temperatures, refrigerant may spurt out from the gap between the valve stem and the valve body, resulting in injuries.

### Revision A:

- A warning when opening or closing the valve has been added.

### Revision B:

- MUZ-GS09/12/15/18/24NA - [U1], MUZ-GS09/12/15/18/24NAH - [U1], MUZ-GS09/12/15/18/24NAHZ - [U1], MUY-GS09/12/15/18/24NA - [U1], MUZ-GS30/36NA2 - [U1], MUZ-GS30/36NAH2 - [U1] and MUY-GS30/36NA2 - [U1] have been added.

# 1

## TECHNICAL CHANGES

MUZ-GS30NA - [U1]

MUZ-GS36NA - [U1]

MUY-GS30NA - [U1]

MUY-GS36NA - [U1]

1. New model

MUZ-GS09NA - [U1]

MUZ-GS12NA - [U1]

MUZ-GS15NA - [U1]

MUZ-GS18NA - [U1]

MUZ-GS24NA - [U1]

MUY-GS09NA - [U1]

MUY-GS12NA - [U1]

MUY-GS15NA - [U1]

MUY-GS18NA - [U1]

MUY-GS24NA - [U1]

1. New model

MUZ-GS30NA2 - [U1]

MUZ-GS36NA2 - [U1]

MUY-GS30NA2 - [U1]

MUY-GS36NA2 - [U1]

1. Compressor protector has been added.

MUZ-GS30NAH - [U1]

MUZ-GS36NAH - [U1]

MUZ-GS09NAH - [U1]

MUZ-GS12NAH - [U1]

MUZ-GS15NAH - [U1]

MUZ-GS18NAH - [U1]

MUZ-GS24NAH - [U1]

MUZ-GS09NAHZ - [U1]

MUZ-GS12NAHZ - [U1]

MUZ-GS15NAHZ - [U1]

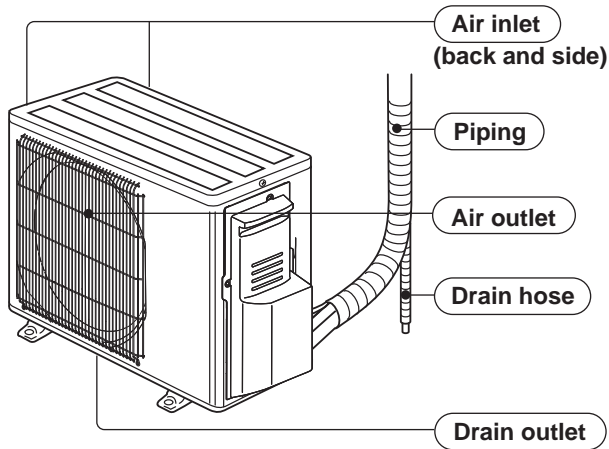
MUZ-GS18NAHZ - [U1]

MUZ-GS24NAHZ - [U1]

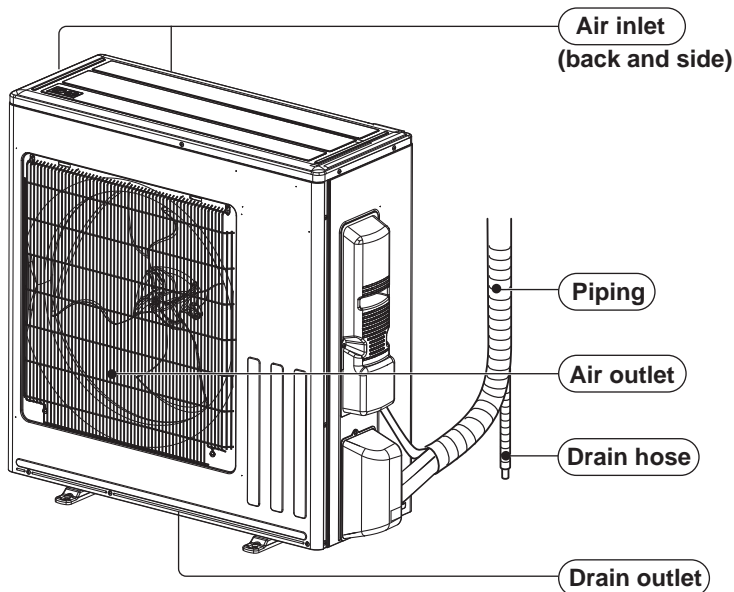
## 2

## PART NAMES AND FUNCTIONS

MUZ-GS09NA    MUZ-GS09NAH    MUZ-GS09NAHZ    MUY-GS09NA  
MUZ-GS12NA    MUZ-GS12NAH    MUZ-GS12NAHZ    MUY-GS12NA  
MUZ-GS15NA    MUZ-GS15NAH    MUZ-GS15NAHZ    MUY-GS15NA



MUZ-GS18NA    MUZ-GS18NAH    MUZ-GS18NAHZ    MUY-GS18NA  
MUZ-GS24NA    MUZ-GS24NAH    MUZ-GS24NAHZ    MUY-GS24NA  
MUZ-GS30NA    MUZ-GS30NAH    MUY-GS30NA  
MUZ-GS30NA2    MUZ-GS30NAH2    MUY-GS30NA2  
MUZ-GS36NA    MUZ-GS36NAH    MUY-GS36NA  
MUZ-GS36NA2    MUZ-GS36NAH2    MUY-GS36NA2



## 3

## SPECIFICATION

Outdoor unit model			MUZ-GS09NA MUZ-GS09NAH MUY-GS09NA	MUZ-GS09NAHZ
Capacity Rated (Minimum – Maximum)	Cooling *1	Btu/h	9,000 (3,600 – 12,200)	
	Heating 47 *1	Btu/h	10,900 (3,600 – 15,900)	9,600 (3,600 – 15,900)
Capacity Rated (Maximum)	Heating 17 *2	Btu/h	6,500 (10,200)	5,700 (11,500)
Power consumption Rated (Minimum – Maximum)	Cooling *1	W	585 (240 – 1,050)	
	Heating 47 *1	W	720 (230 – 1,740)	580 (230 – 1,750)
Power consumption Rated (Maximum)	Heating 17 *2	W	730 (1,230)	650 (1,410)
EER2 *1 [SEER2] *3	Cooling		15.4 [28.4]	
HSPF2 *4	Heating	NA:	10.9	–
		NAH:	10.2	9.6
COP	Heating *1		4.44	4.85
Power factor	Cooling	%	90	
	Heating	%	92	90
Power supply	V , phase , Hz		208/230, 1 , 60	
Max. fuse size (time delay)	A		15	
Min. circuit ampacity	A		10	
Fan motor	A		0.5	
Compressor	Model		SNB092FQAMT	
	R.L.A	A	6.7	
	L.R.A	A	8.4	
	Refrigeration oil	fl oz. (L) (Model)	11.8 (0.35)/(FV50S)	
Refrigerant control			Linear expansion valve	
Sound level *1	Cooling	dB(A)	48	
	Heating	dB(A)	50	
Airflow High - Med. - Low	Cooling	CFM	1,152 – 1,152 – 584	
	Heating	CFM	1,139 – 1,097 – 753	
Fan speed High - Med. - Low	Cooling	rpm	900 – 900 – 490	
	Heating	rpm	890 – 860 – 610	
Defrost method			Reverse cycle (MUZ only)	
Dimensions	W	in.	31-1/2	
	D	in.	11-1/4	
	H	in.	21-5/8	
Weight	lb.	NA: 79 NAH: 81	81	
External finish			Munsell 3Y 7.8/1.1	
Remote controller			Wireless type	
Control voltage (by built-in transformer)	V DC		12 - 24	
Refrigerant piping			Not supplied	
Refrigerant pipe size (Min. wall thickness)	Liquid	in.	1/4 (0.0315)	
	Gas	in.	3/8 (0.0315)	
Connection method	Indoor		Flared	
	Outdoor		Flared	
Between the indoor & outdoor units	Height difference	ft.	40	
	Piping length	ft.	65	
Refrigerant charge (R410A)			2lbs. 9oz	

**NOTE:** Test conditions are based on AHRI 210/240.

\*1: Rating conditions (Cooling) — Indoor: 80°FDB, 67°FWB, Outdoor: 95°FDB, (75°FWB)  
(Heating) — Indoor: 70°FDB, 60°FWB, Outdoor: 47°FDB, 43°FWB

\*2: Rating conditions (Heating) — Indoor: 70°FDB, 60°FWB, Outdoor: 17°FDB, 15°FWB

\*3: Test condition (Refer to page 9.)

\*4: Test condition (Refer to page 9.)





Outdoor unit model			MUZ-GS12NA MUZ-GS12NAH MUY-GS12NA	MUZ-GS12NAHZ	MUZ-GS15NA MUZ-GS15NAH MUY-GS15NA	MUZ-GS15NAHZ
Capacity Rated (Minimum – Maximum)	Cooling *1	Btu/h	12,000 (1,500 – 13,600)		14,000 (3,100 – 18,200)	
	Heating 47 *1	Btu/h	14,400 (1,500 – 18,100)	12,300 (3,600 – 18,100)	18,000 (4,800 – 20,900)	14,000 (4,800 – 20,900)
Capacity Rated (Maximum)	Heating 17 *2	Btu/h	9,000 (12,000)	7,600 (14,700)	12,100 (16,400)	8,700 (16,800)
Power consumption Rated (Minimum – Maximum)	Cooling *1	W	920 (100 – 1,450)		1,100 (210 – 2,020)	
	Heating 47 *1	W	1,100 (110 – 1,750)	830 (240 – 2,020)	1,600 (240 – 2,030)	1,140 (240 – 2,030)
Power consumption Rated (Maximum)	Heating 17 *2	W	1,000 (1,670)	820 (1,820)	1,330 (2,020)	950 (2,020)
EER2 *1 [SEER2] *3	Cooling		13.05 [25.6]	13.05 [21.7]	12.75 [21.0]	
HSPF2 *4	Heating	NA:	10.7	–	11.0	–
		NAH:	10.0	9.6	10.4	9.4
COP	Heating *1		3.84	4.34	3.3	3.6
Power factor	Cooling	%	95		93	
	Heating	%	97	90	96	95
Power supply	V , phase , Hz		208/230, 1 , 60			
Max. fuse size (time delay)	A		15			
Min. circuit ampacity	A		10			
Fan motor	A		0.5			
Compressor	Model		SNB092FQAMT	SNB140FQUMT		
	R.L.A	A	6.7	7.4		
	L.R.A	A	8.4	9.2		
	Refrigeration oil	fl oz. (L) (Model)	11.8 (0.35)/(FV50S)			
Refrigerant control	Linear expansion valve					
Sound level *1	Cooling	dB(A)	49			
	Heating	dB(A)	51			
Airflow High - Med. - Low	Cooling	CFM	1,152 – 1,152 – 584	1,166 – 1,152 – 584	1,166 – 1,166 – 584	
	Heating	CFM	1,139 – 1,097 – 753	1,139 – 1,097 – 753	1,152 – 1,152 – 753	
Fan speed High - Med. - Low	Cooling	rpm	900 – 900 – 490	910 – 900 – 490	910 – 910 – 490	
	Heating	rpm	890 – 860 – 610	900 – 860 – 610	900 – 900 – 610	
Defrost method	Reverse cycle (MUZ only)					
Dimensions	W	in.	31-1/2			
	D	in.	11-1/4			
	H	in.	21-5/8			
Weight	lb.	NA: 79 NAH: 81	85	NA: 84 NAH: 85	85	
External finish	Munsell 3Y 7.8/1.1					
Remote controller	Wireless type					
Control voltage (by built-in transformer)	V DC		12 - 24			
Refrigerant piping	Not supplied					
Refrigerant pipe size (Min. wall thickness)	Liquid	in.	1/4 (0.0315)			
	Gas	in.	3/8 (0.0315)		1/2 (0.0315)	
Connection method	Indoor		Flared			
	Outdoor		Flared			
Between the indoor & outdoor units	Height difference	ft.	40			
	Piping length	ft.	65			
Refrigerant charge (R410A)	2lbs. 9oz					

**NOTE:** Test conditions are based on AHRI 210/240.

\*1: Rating conditions (Cooling) — Indoor: 80°FDB, 67°FWB, Outdoor: 95°FDB, (75°FWB)  
(Heating) — Indoor: 70°FDB, 60°FWB, Outdoor: 47°FDB, 43°FWB

\*2: Rating conditions (Heating) — Indoor: 70°FDB, 60°FWB, Outdoor: 17°FDB, 15°FWB

\*3: Test condition (Refer to page 9.)

\*4: Test condition (Refer to page 9.)

Outdoor unit model			MUZ-GS18NA MUZ-GS18NAH MUY-GS18NA	MUZ-GS18NAHZ	MUZ-GS24NA MUZ-GS24NAH MUY-GS24NA	MUZ-GS24NAHZ
Capacity Rated (Minimum – Maximum)	Cooling *1	Btu/h	18,000 (5,800 – 22,000)		22,400 (8,200 – 31,400)	
	Heating 47 *1	Btu/h	NA:21,600 NAH:20,600 (5,400 – 25,000)	19,000 (6,600 – 25,000)	27,600 (7,500 – 31,400)	21,200 (7,500 – 31,400)
Capacity Rated (Maximum)	Heating 17 *2	Btu/h	13,300 (18,200)	11,700 (22,400)	17,600 (24,600)	13,300 (25,400)
Power consumption Rated (Minimum – Maximum)	Cooling *1	W	1,340 (330 – 2,150)		1,780 (570 – 4,000)	
	Heating 47 *1	W	1,680 (320 – 2,500)	1,340 (400 – 4,000)	2,340 (520 – 4,050)	1,540 (520 – 4,050)
Power consumption Rated (Maximum)	Heating 17 *2	W	1,460 (2,080)	1,230 (3,570)	1,930 (2,950)	1,400 (3,350)
EER2 *1 [SEER2] *3	Cooling		13.45 [21.5]		12.6 [21.5]	
HSPF2 *4	Heating	NA:	10.3	–	10.3	–
		NAH:	10.0	9.6	10.1	9.0
COP	Heating *1		3.77	4.16	3.46	4.03
Power factor	Cooling	%	97	98	99	
	Heating	%	97	98	95	98
Power supply	V , phase , Hz		208/230, 1 , 60			
Max. fuse size (time delay)	A		15	20		
Min. circuit ampacity	A		12	18		
Fan motor	A		0.93			
Compressor	Model		SNB130FQBMT	SNB172FQKMT		
	R.L.A	A	8.4	13.6		
	L.R.A	A	10.5	17		
	Refrigeration oil	fl oz. (L) (Model)	11.8 (0.35)/(FV50S)	13.5 (0.40)/(FV50S)		
Refrigerant control	Linear expansion valve					
Sound level *1	Cooling	dB(A)	54		55	
	Heating	dB(A)	55			
Airflow High - Med. - Low	Cooling	CFM	2,662 – 1,947 – 1,334	2,191 – 1,800 – 1,024	2,191 – 1,950 – 1,034	
	Heating	CFM	2,187 – 1,732 – 1,251	1,950 – 1,646 – 1,219	1,950 – 1,950 – 1,328	
Fan speed High - Med. - Low	Cooling	rpm	900 – 740 – 550	900 – 740 – 450	900 – 800 – 450	
	Heating	rpm	800 – 680 – 520	800 – 680 – 520	800 – 800 – 560	
Defrost method	Reverse cycle (MUZ only)					
Dimensions	W	in.	33-1/16			
	D	in.	13			
	H	in.	34-5/8			
Weight	lb.	NA: 119 NAH: 120	118	NA: 118 NAH: 120	120	
External finish	Munsell 3Y 7.8/1.1					
Remote controller	Wireless type					
Control voltage (by built-in transformer)	V DC		12 - 24			
Refrigerant piping	Not supplied					
Refrigerant pipe size (Min. wall thickness)	Liquid	in.	1/4 (0.0315)			
	Gas	in.	1/2 (0.0315)		5/8 (0.0394)	
Connection method	Indoor		Flared			
	Outdoor		Flared			
Between the indoor & outdoor units	Height difference	ft.	50			
	Piping length	ft.	100			
Refrigerant charge (R410A)			3lbs. 7oz		4lbs. 5oz	

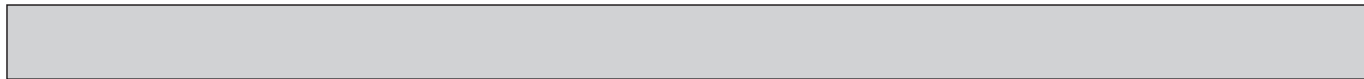
**NOTE:** Test conditions are based on AHRI 210/240.

\*1: Rating conditions (Cooling) — Indoor: 80°FDB, 67°FWB, Outdoor: 95°FDB, (75°FWB)  
(Heating) — Indoor: 70°FDB, 60°FWB, Outdoor: 47°FDB, 43°FWB

\*2: Rating conditions (Heating) — Indoor: 70°FDB, 60°FWB, Outdoor: 17°FDB, 15°FWB

\*3: Test condition (Refer to page 9.)

\*4: Test condition (Refer to page 9.)



Outdoor unit model			MUZ-GS30NA MUZ-GS30NAH	MUY-GS30NA	MUZ-GS36NA MUZ-GS36NAH	MUY-GS36NA
Capacity Rated (Minimum – Maximum)	Cooling *1	Btu/h	30,700 (10,300 – 30,700)		32,000/33,200 (10,300 – 32,000)/(10,300 – 33,200)	
	Heating 47 *1	Btu/h	32,600 (9,800 – 34,000)	–	35,200 (9,800 – 36,000)	–
Capacity Rated (Maximum)	Heating 17 *2	Btu/h	20,000 (20,800)	–	21,600 (22,800)	–
Power consumption Rated (Minimum – Maximum)	Cooling *1	W	3,320 (650 – 3,320)		3,630/3,770 (650 – 3,630)/(650 – 3,770)	
	Heating 47 *1	W	3,340 (590 – 3,580)	–	3,740 (590 – 4,000)	–
Power consumption Rated (Maximum)	Heating 17 *2	W	2,500 (2,600)	–	2,770 (2,920)	–
EER *1 [SEER] *3	Cooling		9.2 [18.1]		8.8 [16.2]	
HSPF IV *4	Heating	NA:	9.6	–	10	–
		NAH:	9.4	–	9.8	–
COP	Heating *1		2.86	–	2.76	–
Power supply	V , phase , Hz		208/230, 1 , 60			
Max. fuse size (time delay)	A		20			
Min. circuit ampacity	A		19			
Fan motor	F.L.A	A	0.93			
Compressor	Model		SNB220FQAM1T			
	R.L.A	A	13.8			
	L.R.A	A	17.3			
	Refrigeration oil	fl oz. (L)/ (Model)	15.6 (0.46)/(FV50S)			
Refrigerant control	Linear expansion valve					
Sound level *1	Cooling	dB(A)	55		56	
	Heating	dB(A)	57	–	57	–
Defrost method	Reverse cycle					
Dimensions	W	in.	33-1/16			
	D	in.	13			
	H	in.	34-5/8			
Weight	lb.		NA: 121 NAH: 122			
External finish	Munsell 3Y 7.8/1.1					
Remote controller	Wireless type					
Control voltage (by built-in transformer)	V DC		12 – 24			
Refrigerant piping	Not supplied					
Refrigerant pipe size (Min. wall thickness)	Liquid	in.	1/4 (0.0315)			
	Gas	in.	5/8 (0.0394)			
Connection method	Indoor		Flared			
	Outdoor		Flared			
Between the indoor & outdoor units	Height difference	ft.	50			
	Piping length	ft.	100			
Refrigerant charge (R410A)	4 lb.					

**NOTE:** Test conditions are based on AHRI 210/240.

\*1: Rating conditions (Cooling) — Indoor: 80°FDB, 67°FWB, Outdoor: 95°FDB, (75°FWB)  
(Heating) — Indoor: 70°FDB, 60°FWB, Outdoor: 47°FDB, 43°FWB

\*2: Rating conditions (Heating) — Indoor: 70°FDB, 60°FWB, Outdoor: 17°FDB, 15°FWB

\*3: Test condition (Refer to page 9.)

\*4: Test condition (Refer to page 9.)

Outdoor unit model			MUZ-GS30NA2 MUZ-GS30NAH2	MUY-GS30NA2	MUZ-GS36NA2 MUZ-GS36NAH2	MUY-GS36NA2
Capacity Rated (Minimum – Maximum)	Cooling *1	Btu/h	30,600(10,300-30,700)		33,200 (10,300 – 33,200)	
	Heating 47 *1	Btu/h	32,600 (9,800 – 34,000)	–	35,200 (9,800 – 36,000)	–
Capacity Rated (Maximum)	Heating 17 *2	Btu/h	20,000 (20,800)	–	21,600 (22,800)	–
Power consumption Rated (Minimum – Maximum)	Cooling *1	W	3,320 (650 – 3,320)		3,770 (650 – 3,770)	
	Heating 47 *1	W	3,340 (590 – 3,580)	–	3,740 (590 – 4,000)	–
Power consumption Rated (Maximum)	Heating 17 *2	W	2,500 (2,600)	–	2,770 (2,920)	–
EEER2 *1 [SEER2] *3	Cooling		9.2 [19.1]	9.2 [19.2]	8.8 [18.4]	8.8 [18.5]
HSPF2 *4	Heating	NA:	8.9	–	8.5	–
		NAH:	8.7	–	8.3	–
COP	Heating *1		2.86	–	2.76	–
Power factor	Cooling		98	98	98	98
	Heating		98	–	99	–
Power supply	V , phase , Hz		208/230, 1 , 60			
Max. fuse size (time delay)	A		25			
Min. circuit ampacity	A		NA: 22 NAH: 23			
Fan motor	F.L.A	A	0.93			
Compressor	Model		SNB220FQAM1T			
	R.L.A	A	13.8			
	L.R.A	A	17.3			
	Refrigeration oil	fl oz. (L)/ (Model)	15.6 (0.46)/(FV50S)			
Refrigerant control	Linear expansion valve					
Sound level *1	Cooling	dB(A)	55		56	
	Heating	dB(A)	57	–	57	–
Airflow High - Med. - Low	Cooling	CFM	2,191 – 1,975 – 1,024	2,229 – 1,990 – 1,010	2,191 – 2,191 – 1,024	2,229 – 2,070 – 1,010
	Heating	CFM	1,950 – 1,950 – 1,328	–	1,950 – 1,950 – 1,328	–
Fan speed High - Med. - Low	Cooling	rpm	900 – 810 – 450	900 – 810 – 450	900 – 900 – 450	900 – 840 – 450
	Heating	rpm	800 – 800 – 560	–	800 – 800 – 560	–
Defrost method	Reverse cycle					
Dimensions	W	in.	33 - 1/16			
	D	in.	13			
	H	in.	34 - 5/8			
Weight	lb.	NA: 122 NAH: 123	112	NA: 122 NAH: 123	112	
External finish	Munsell 3Y 7.8/1.1					
Remote controller	Wireless type					
Control voltage (by built-in transformer)	V DC		12 - 24			
Refrigerant piping	Not supplied					
Refrigerant pipe size (Min. wall thickness)	Liquid	in.	1/4 (0.0315)			
	Gas	in.	5/8 (0.0394)			
Connection method	Indoor		Flared			
	Outdoor		Flared			
Between the indoor & outdoor units	Height difference	ft.	50			
	Piping length	ft.	100			
Refrigerant charge (R410A)	4lb. 5oz					

**NOTE:** Test conditions are based on AHRI 210/240.

\*1: Rating conditions (Cooling) — Indoor: 80°FDB, 67°FWB, Outdoor: 95°FDB, (75°FWB)  
(Heating) — Indoor: 70°FDB, 60°FWB, Outdoor: 47°FDB, 43°FWB

\*2: Rating conditions (Heating) — Indoor: 70°FDB, 60°FWB, Outdoor: 17°FDB, 15°FWB

\*3: Test condition (Refer to page 9.)

\*4: Test condition (Refer to page 9.)

## Test condition

\*3, \*4

AHRI 210/240	Mode	Test	Indoor air condition (°F)		Outdoor air condition (°F)	
			Dry bulb	Wet bulb	Dry bulb	Wet bulb
	SEER (Cooling)	"A-Full" Cooling Steady State at rated compressor speed	80	67	95	(75)
		"B-Full" Cooling Steady State at rated compressor speed	80	67	82	(65)
		"B-Low" Cooling Steady State at minimum compressor speed	80	67	82	(65)
		"F-Low" Cooling Steady State at minimum compressor speed	80	67	67	(53.5)
		"E-Int" Cooling Steady State at intermediate compressor speed *5	80	67	87	(69)
	HSPF (Heating)	"H1-Nom" Heating Steady State at rated compressor speed	70	60	47	43
		"H3-Full" Heating at rated compressor speed	70	60	17	15
		"H0-Low" Heating Steady State at minimum compressor speed	70	60	62	56.5
		"H1-Low" Heating Steady State at minimum compressor speed	70	60	47	43
		"H2-Int" Heating at intermediate compressor speed *5	70	60	35	33

\*5: At intermediate compressor speed  
= ("Rated compressor speed" - "minimum compressor speed") / 3 + "minimum compressor speed".

## OPERATING RANGE

### (1) POWER SUPPLY

	Rated voltage	Guaranteed voltage (V)
Outdoor unit	208/230 V 1 phase 60 Hz	Min. 187    208    230    Max. 253 ----- ----- ----- ----- -----

### (2) OPERATION

Mode	Condition	Intake air temperature (°F)	
		Outdoor	
		DB	WB
Cooling	Standard temperature	95	—
	Maximum temperature	115	—
	Minimum temperature	14	—
	Maximum humidity	—	
Heating	Standard temperature	47	43
	Maximum temperature	75	65
	Minimum temperature	<b>NA, NAH: -4</b> <b>NAHZ: -13</b>	<b>NA, NAH: -5</b> <b>NAHZ: -14</b>

# 4

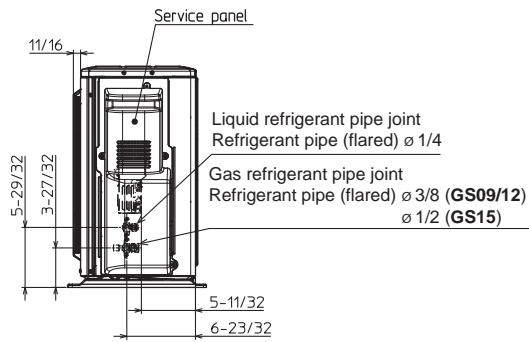
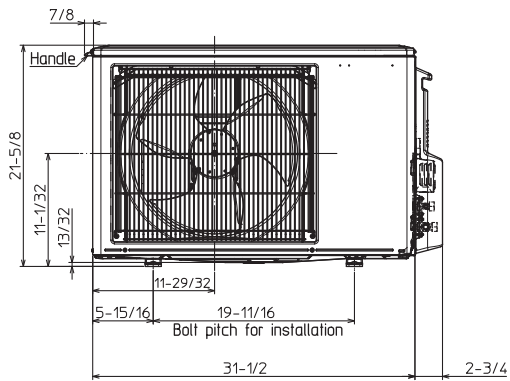
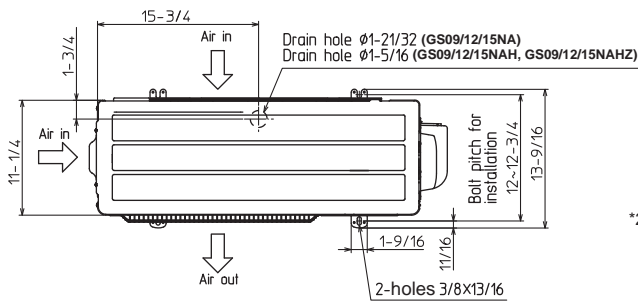
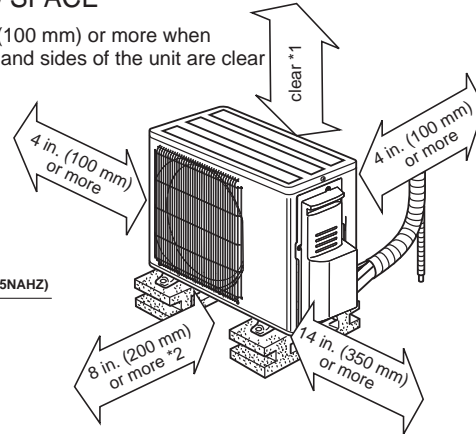
# OUTLINES AND DIMENSIONS

MUZ-GS09NA MUZ-GS09NAH MUZ-GS09NAHZ MUY-GS09NA  
 MUZ-GS12NA MUZ-GS12NAH MUZ-GS12NAHZ MUY-GS12NA  
 MUZ-GS15NA MUZ-GS15NAH MUZ-GS15NAHZ MUY-GS15NA

Unit: inch

### REQUIRED SPACE

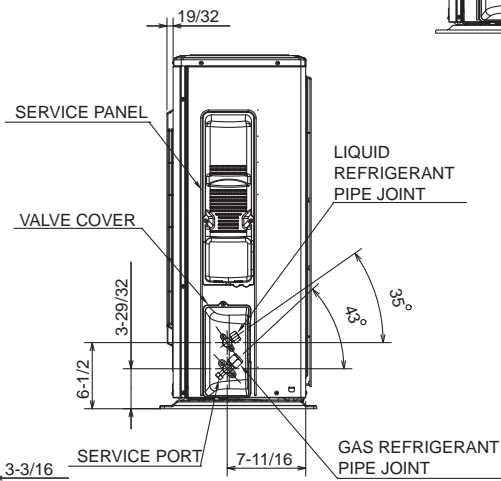
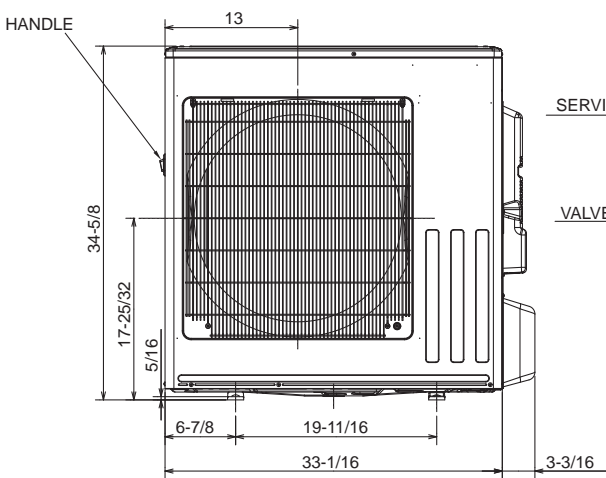
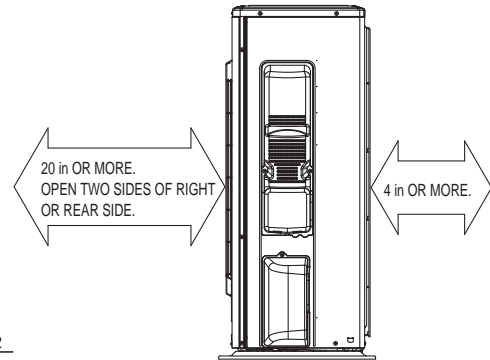
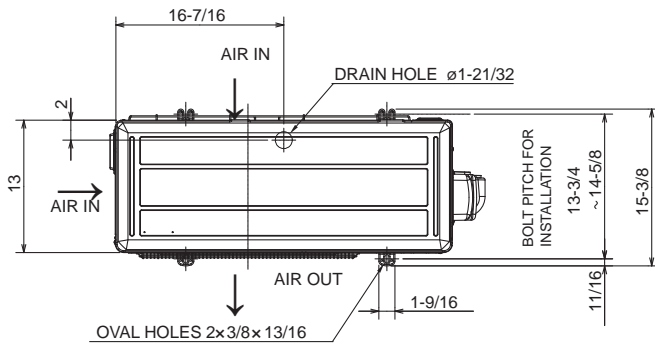
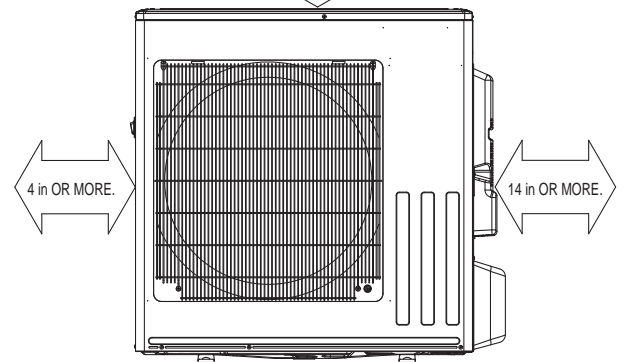
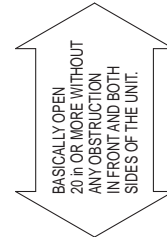
\*1 4 in. (100 mm) or more when front and sides of the unit are clear



**MUZ-GS18NA    MUZ-GS18NAH    MUZ-GS18NAHZ    MUY-GS18NA**  
**MUZ-GS24NA    MUZ-GS24NAH    MUZ-GS24NAHZ    MUY-GS24NA**  
**MUZ-GS30NA    MUZ-GS30NAH    MUY-GS30NA**  
**MUZ-GS30NA2    MUZ-GS30NAH2    MUY-GS30NA2**  
**MUZ-GS36NA    MUZ-GS36NAH    MUY-GS36NA**  
**MUZ-GS36NA2    MUZ-GS36NAH2    MUY-GS36NA2**

Unit: inch

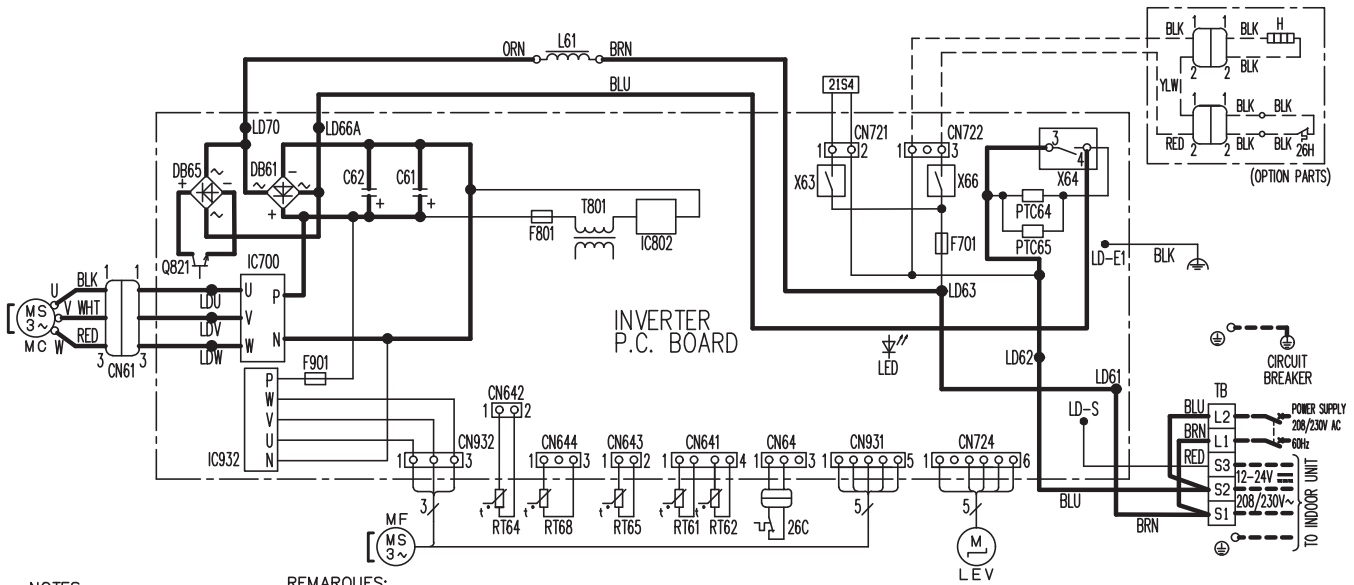
REQUIRED SPACE



REFRIGERANT PIPE JOINT	LIQUID REFRIGERANT PIPE	FLARED ø6.35 (1/4")
	GAS REFRIGERANT PIPE	GS18: FLARED ø12.7 (1/2")
		GS24/30/36: FLARED ø15.88 (5/8")



MUZ-GS09NA MUZ-GS12NA MUZ-GS15NA



NOTES:

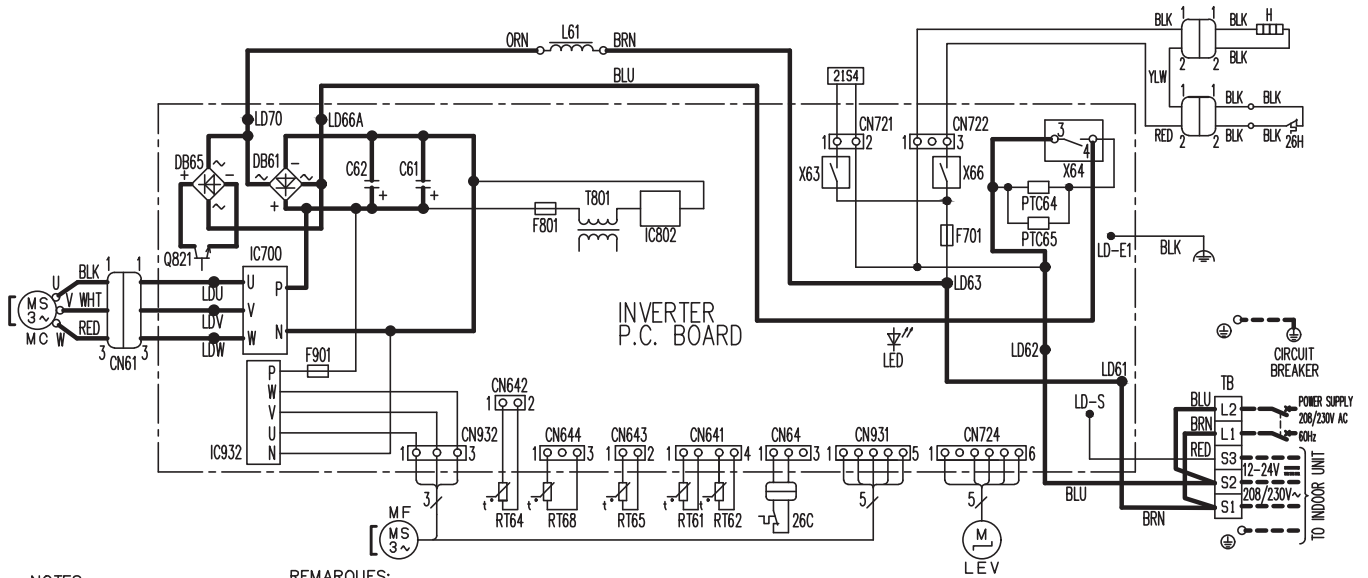
- About the indoor side electric wiring, refer to the indoor unit electric wiring diagram for servicing.
- Use copper supply wires.
- Symbols indicate, : Terminal block : Connector

REMARQUES:

- Pour le câblage électronique côté intérieur, se reporter au schéma d'entretien du câblage électronique de l'appareil intérieur.
- Utiliser des fils d'alimentation en cuivre.
- Les symboles ont les significations suivantes, : Borne : Connecteur

SYMBOL	NAME	SYMBOL	NAME	SYMBOL	NAME
CN61	CONNECTOR	L61	REACTOR	RT68	OUTDOOR HEAT EXCHANGER TEMP. THERMISTOR
C61,C62	SMOOTHING CAPACITOR	MC	COMPRESSOR	TB	TERMINAL BLOCK
DB61,DB65	DIODE MODULE	MF	FAN MOTOR	T801	TRANSFORMER
F701,F801,F901	FUSE (T3, 15AL250V)	PTC64,PTC65	CIRCUIT PROTECTION	X63,X64,X66	RELAY
H	DEFROST HEATER (OPTION PARTS)	Q821	SWITCHING POWER TRANSISTOR	21S4	REVERSING VALVE COIL
IC700,IC932	POWER MODULE	RT61	DEFROST THERMISTOR	26C	COMPRESSOR PROTECTOR
IC802	POWER DEVICE	RT62	DISCHARGE TEMP. THERMISTOR	26H	HEATER PROTECTOR (OPTION PARTS)
LED	LED	RT64	FIN TEMP. THERMISTOR		
LEV	EXPANSION VALVE COIL	RT65	AMBIENT TEMP. THERMISTOR		

**MUZ-GS09NAH MUZ-GS09NAHZ MUZ-GS12NAH MUZ-GS12NAHZ  
MUZ-GS15NAH MUZ-GS15NAHZ**

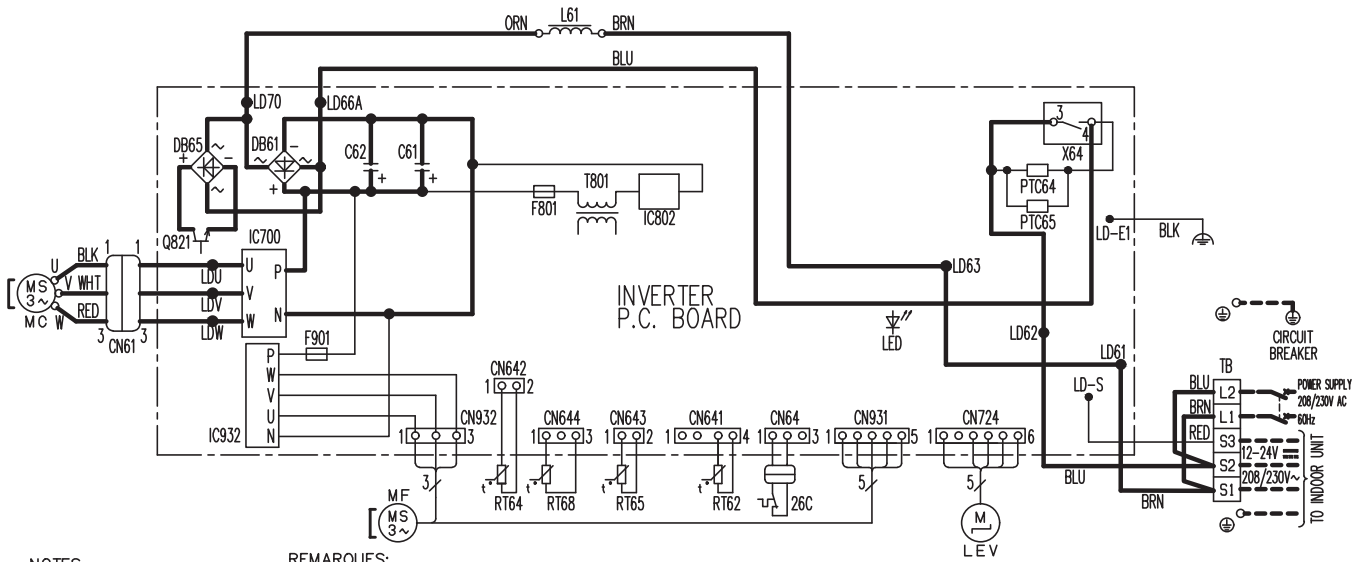


**NOTES:**  
 1.About the indoor side electric wiring, refer to the indoor unit electric wiring diagram for servicing.  
 2.Use copper supply wires.  
 3.Symbols indicate, :Terminal block :Connector

**REMARQUES:**  
 1.Pour le câblage électronique côté intérieur, se reporter au schéma d'entretien du câblage électronique de l'appareil intérieur.  
 2.Utiliser des fils d'alimentation en cuivre.  
 3.Les symboles ont les significations suivantes, :Borne :Connecteur

SYMBOL	NAME	SYMBOL	NAME	SYMBOL	NAME
CN61	CONNECTOR	L61	REACTOR	RT68	OUTDOOR HEAT EXCHANGER TEMP. THERMISTOR
C61,C62	SMOOTHING CAPACITOR	MC	COMPRESSOR	TB	TERMINAL BLOCK
DB61,DB65	DIODE MODULE	MF	FAN MOTOR	T801	TRANSFORMER
F701,F801,F901	FUSE (T3, 15AL250V)	PTC64,PTC65	CIRCUIT PROTECTION	X63,X64,X66	RELAY
H	DEFROST HEATER	Q821	SWITCHING POWER TRANSISTOR	21S4	REVERSING VALVE COIL
IC700,IC932	POWER MODULE	RT61	DEFROST THERMISTOR	26C	COMPRESSOR PROTECTOR
IC802	POWER DEVICE	RT62	DISCHARGE TEMP. THERMISTOR	26H	HEATER PROTECTOR
LED	LED	RT64	FIN TEMP. THERMISTOR		
LEV	EXPANSION VALVE COIL	RT65	AMBIENT TEMP. THERMISTOR		

# MUY-GS09NA MUY-GS12NA MUY-GS15NA



**NOTES:**

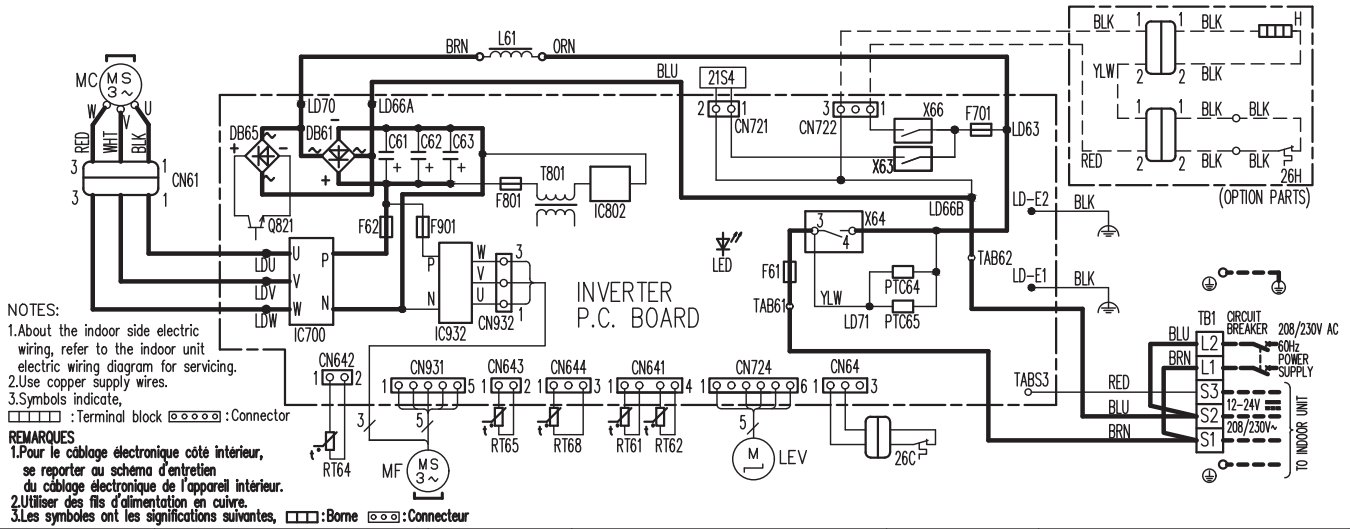
- About the indoor side electric wiring, refer to the indoor unit electric wiring diagram for servicing.
- Use copper supply wires.
- Symbols indicate, : Terminal block : Connector

**REMARQUES:**

- Pour le câblage électronique côté intérieur, se reporter au schéma d'entretien du câblage électronique de l'appareil intérieur.
- Utiliser des fils d'alimentation en cuivre.
- Les symboles ont les significations suivantes, : Borne : Connecteur

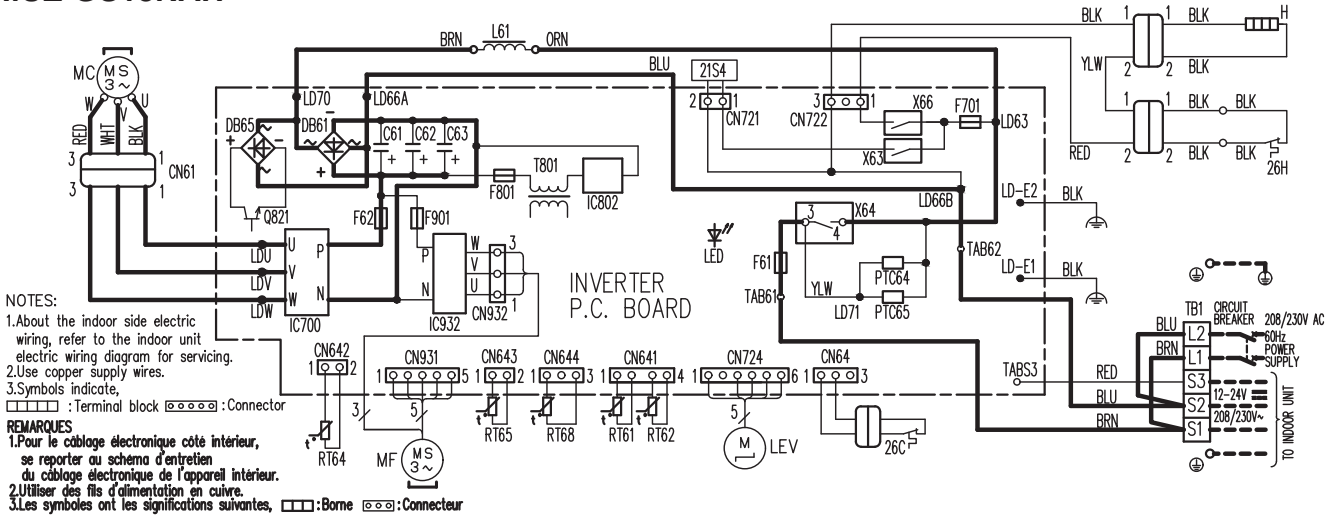
SYMBOL	NAME	SYMBOL	NAME	SYMBOL	NAME
CN61	CONNECTOR	L61	REACTOR	RT68	OUTDOOR HEAT EXCHANGER TEMP. THERMISTOR
C61,C62	SMOOTHING CAPACITOR	MC	COMPRESSOR	TB	TERMINAL BLOCK
DB61,DB65	DIODE MODULE	MF	FAN MOTOR	T801	TRANSFORMER
F801,F901	FUSE (T3, 15A/250V)	PTC64,PTC65	CIRCUIT PROTECTION	X64	RELAY
IC700,IC932	POWER MODULE	Q821	SWITCHING POWER TRANSISTOR	26C	COMPRESSOR PROTECTOR
IC802	POWER DEVICE	RT62	DISCHARGE TEMP. THERMISTOR		
LED	LED	RT64	FIN TEMP. THERMISTOR		
LEV	EXPANSION VALVE COIL	RT65	AMBIENT TEMP. THERMISTOR		

# MUZ-GS18NA



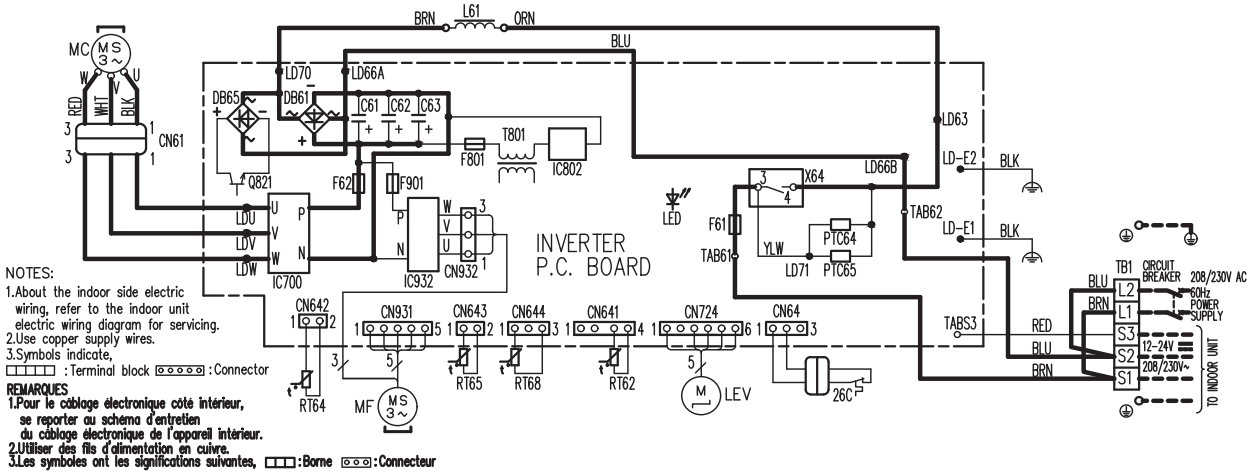
SYMBOL	NAME	SYMBOL	NAME	SYMBOL	NAME
CN61	CONNECTOR	LEV	EXPANSION VALVE COIL	RT68	OUTDOOR HEAT EXCHANGER TEMP. THERMISTOR
C61,C62,C63	SMOOTHING CAPACITOR	L61	REACTOR	TB1	TERMINAL BLOCK
DB61,DB65	DIODE MODULE	MC	COMPRESSOR	T801	TRANSFORMER
F61	FUSE (25A 250V)	MF	FAN MOTOR	PTC64, PTC65	CIRCUIT PROTECTION
F62	FUSE (15A 250V)	Q821	SWITCHING POWER TRANSISTOR	X63, X64, X66	RELAY
F701,F801,F901	FUSE (T3.15AL250V)	21S4	REVERSING VALVE COIL	26C	COMPRESSOR PROTECTOR
H	DEFROST HEATER	IC700, IC932	POWER MODULE	26H	HEATER PROTECTOR (OPTION PARTS)
IC700, IC932	POWER MODULE	IC802	POWER DEVICE		
IC802	POWER DEVICE	LED	LED		

# MUZ-GS18NAH



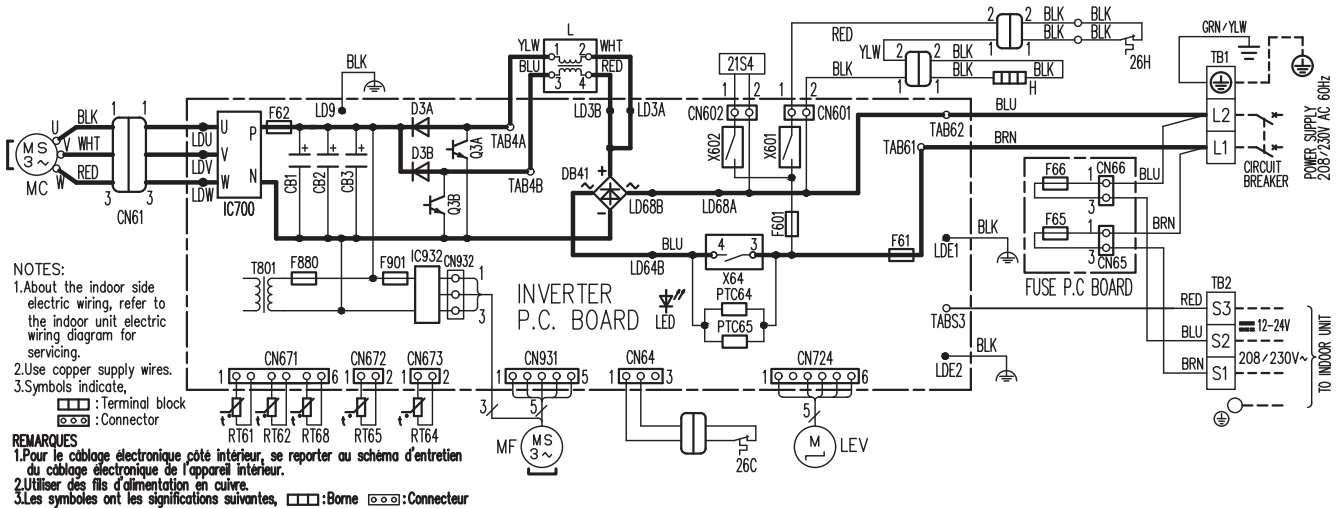
SYMBOL	NAME	SYMBOL	NAME	SYMBOL	NAME
CN61	CONNECTOR	LEV	EXPANSION VALVE COIL	RT68	OUTDOOR HEAT EXCHANGER TEMP. THERMISTOR
C61,C62,C63	SMOOTHING CAPACITOR	L61	REACTOR	TB1	TERMINAL BLOCK
DB61,DB65	DIODE MODULE	MC	COMPRESSOR	T801	TRANSFORMER
F61	FUSE (25A 250V)	MF	FAN MOTOR	PTC64, PTC65	CIRCUIT PROTECTION
F62	FUSE (15A 250V)	Q821	SWITCHING POWER TRANSISTOR	X63, X64, X66	RELAY
F701,F801,F901	FUSE (T3.15AL250V)	21S4	REVERSING VALVE COIL	26C	COMPRESSOR PROTECTOR
H	DEFROST HEATER	IC700, IC932	POWER MODULE	26H	HEATER PROTECTOR
IC700, IC932	POWER MODULE	IC802	POWER DEVICE		
IC802	POWER DEVICE	LED	LED		

## MUY-GS18NA



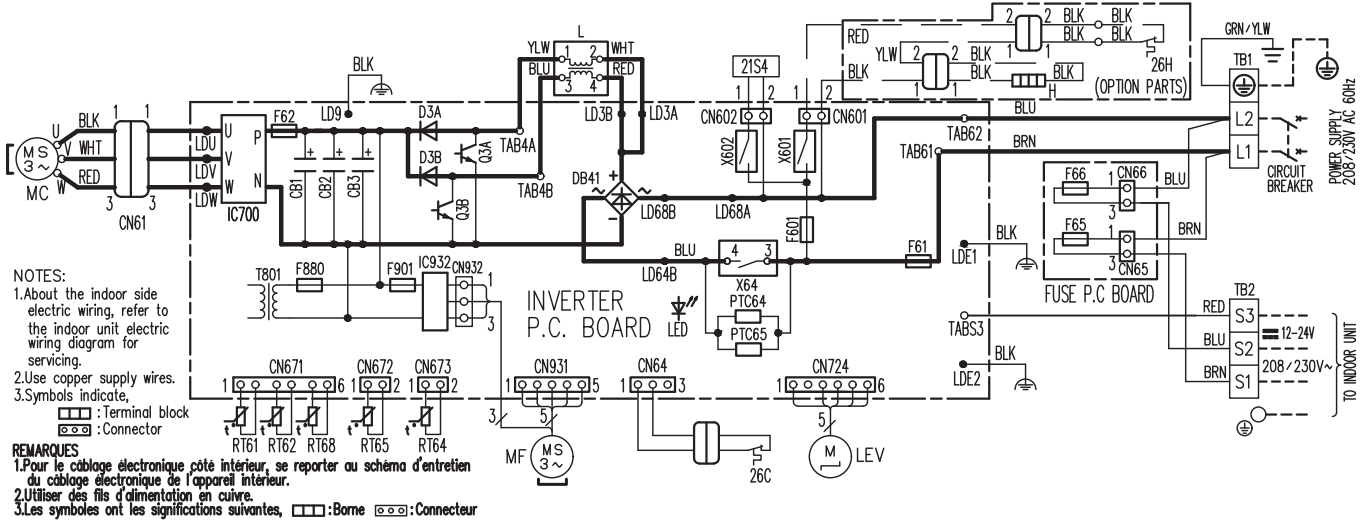
SYMBOL	NAME	SYMBOL	NAME	SYMBOL	NAME
CN61	CONNECTOR	LEV	EXPANSION VALVE COIL	RT68	OUTDOOR HEAT EXCHANGER TEMP. THERMISTOR
C61,C62,C63	SMOOTHING CAPACITOR	MC	COMPRESSOR	TB1	TERMINAL BLOCK
DB61,DB65	DIODE MODULE	MF	FAN MOTOR	T801	TRANSFORMER
F61	FUSE (25A 250V)	PTC64,PTC65	CIRCUIT PROTECTION	X64	RELAY
F62	FUSE (15A 250V)	Q821	SWITCHING POWER TRANSISTOR	26C	COMPRESSOR PROTECTOR
F801,F901	FUSE (T3.15AL250V)	RT62	DISCHARGE TEMP. THERMISTOR		
IC700,IC932	POWER MODULE	RT64	FIN TEMP. THERMISTOR		
IC802	POWER DEVICE	RT65	AMBIENT TEMP. THERMISTOR		
LED	LED				

## MUZ-GS18NAHZ MUZ-GS24NAH MUZ-GS24NAHZ



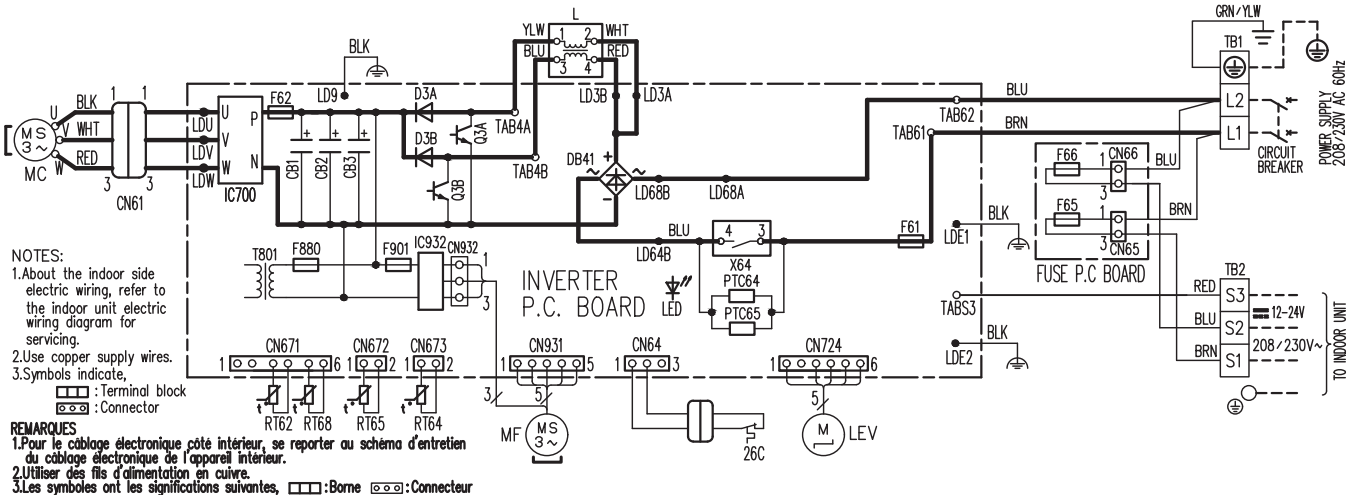
SYMBOL	NAME	SYMBOL	NAME	SYMBOL	NAME
CB1,CB2,CB3	SMOOTHING CAPACITOR	L	REACTOR	RT65	AMBIENT TEMP. THERMISTOR
CN61	CONNECTOR	LED	LED	RT68	OUTDOOR HEAT EXCHANGER TEMP. THERMISTOR
DB41	DIODE MODULE	LEV	EXPANSION VALVE COIL	TB1,TB2	TERMINAL BLOCK
D3A,D3B	DIODE	MC	COMPRESSOR	T801	TRANSFORMER
F61	FUSE (25A 250V)	MF	FAN MOTOR	X64,X601,X602	RELAY
F62	FUSE (15A 250V)	PTC64,PTC65	CIRCUIT PROTECTION	21S4	REVERSING VALVE COIL
F65,F66	FUSE (T6.3AL250V)	Q3A,Q3B	SWITCHING POWER TRANSISTOR	26C	COMPRESSOR PROTECTOR
F601,F880,F901	FUSE (T3.15AL250V)	RT61	DEFROST TEMP. THERMISTOR	26H	HEATER PROTECTOR
H	DEFROST HEATER	RT62	DISCHARGE TEMP. THERMISTOR		
IC700,IC932	POWER MODULE	RT64	FIN TEMP. THERMISTOR		

# MUZ-GS24NA



SYMBOL	NAME	SYMBOL	NAME	SYMBOL	NAME
CB1, CB2, CB3	SMOOTHING CAPACITOR	L	REACTOR	RT65	AMBIENT TEMP. THERMISTOR
CN61	CONNECTOR	LED	LED	RT68	OUTDOOR HEAT EXCHANGER TEMP. THERMISTOR
DB41	DIODE MODULE	LEV	EXPANSION VALVE COIL	TB1, TB2	TERMINAL BLOCK
D3A, D3B	DIODE	MC	COMPRESSOR	T801	TRANSFORMER
F61	FUSE (25A 250V)	MF	FAN MOTOR	X64, X601, X602	RELAY
F62	FUSE (15A 250V)	PTC64, PTC65	CIRCUIT PROTECTION	21S4	REVERSING VALVE COIL
F65, F66	FUSE (T6.3AL250V)	Q3A, Q3B	SWITCHING POWER TRANSISTOR	26C	COMPRESSOR PROTECTOR
F601, F880, F901	FUSE (T3.15AL250V)	RT61	DEFROST TEMP. THERMISTOR	26H	HEATER PROTECTOR (OPTION PARTS)
H	DEFROST HEATER	RT62	DISCHARGE TEMP. THERMISTOR		
IC700, IC932	POWER MODULE	RT64	FIN TEMP. THERMISTOR		

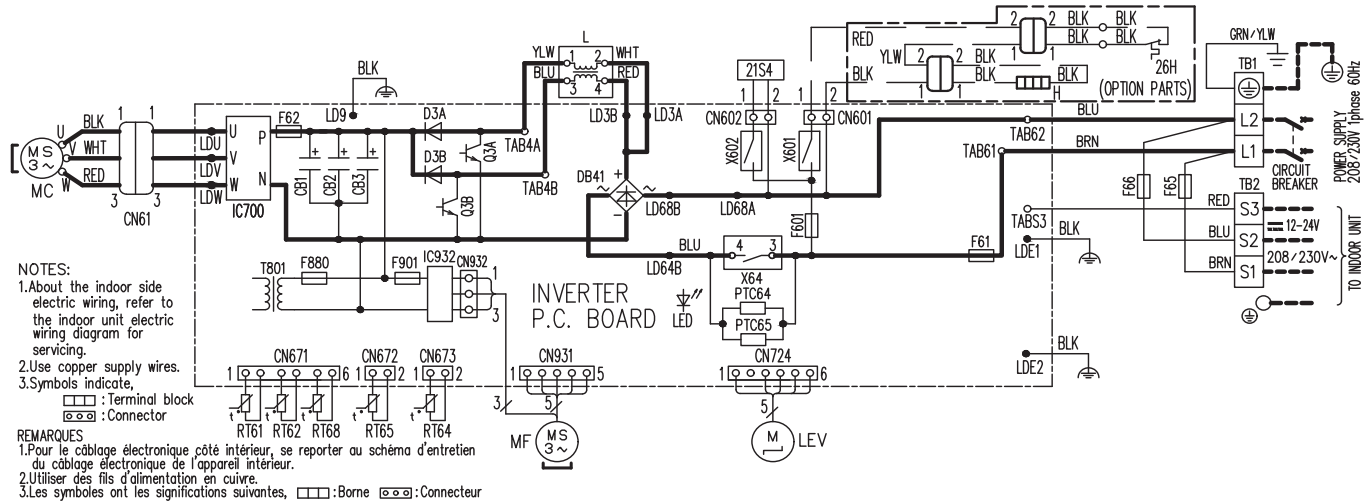
# MUY-GS24NA



SYMBOL	NAME	SYMBOL	NAME	SYMBOL	NAME
CB1, CB2, CB3	SMOOTHING CAPACITOR	L	REACTOR	RT65	AMBIENT TEMP. THERMISTOR
CN61	CONNECTOR	LED	LED	RT68	OUTDOOR HEAT EXCHANGER TEMP. THERMISTOR
DB41	DIODE MODULE	LEV	EXPANSION VALVE COIL	TB1, TB2	TERMINAL BLOCK
D3A, D3B	DIODE	MC	COMPRESSOR	T801	TRANSFORMER
F61	FUSE (25A 250V)	MF	FAN MOTOR	X64	RELAY
F62	FUSE (15A 250V)	PTC64, PTC65	CIRCUIT PROTECTION	26C	COMPRESSOR PROTECTOR
F65, F66	FUSE (T6.3AL250V)	Q3A, Q3B	SWITCHING POWER TRANSISTOR		
F880, F901	FUSE (T3.15AL250V)	RT62	DISCHARGE TEMP. THERMISTOR		
IC700, IC932	POWER MODULE	RT64	FIN TEMP. THERMISTOR		

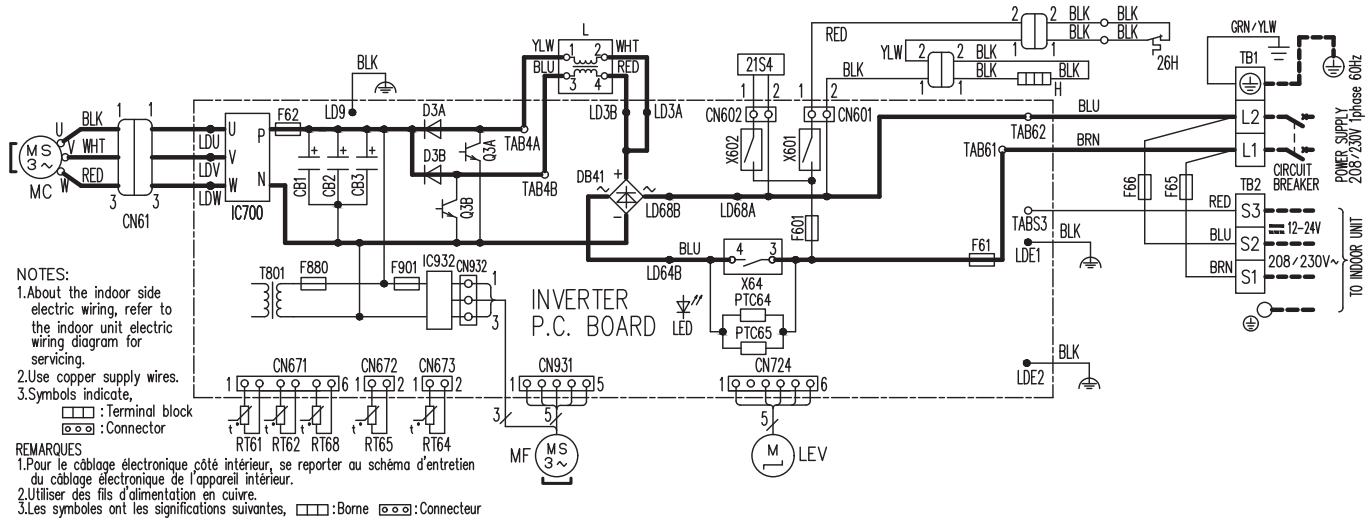


## MUZ-GS30NA MUZ-GS36NA



SYMBOL	NAME	SYMBOL	NAME	SYMBOL	NAME
CB1,CB2,CB3	SMOOTHING CAPACITOR	LED	LED	RT68	OUTDOOR HEAT EXCHANGER TEMP. THERMISTOR
CN61	CONNECTOR	LEV	EXPANSION VALVE COIL	TB1,TB2	TERMINAL BLOCK
DB41	DIODE MODULE	MC	COMPRESSOR	T801	TRANSFORMER
D3A,D3B	DIODE	MF	FAN MOTOR	X64,X601,X602	RELAY
F61	FUSE (25A 250V)	PTC64,PTC65	CIRCUIT PROTECTION	21S4	REVERSING VALVE COIL
F62	FUSE (15A 250V)	Q3A,Q3B	SWITCHING POWER TRANSISTOR	26H	HEATER PROTECTOR (OPTION PARTS)
F65,F66	FUSE (T6.3AL250V)	RT61	DEFROST TEMP. THERMISTOR		
F601,F880,F901	FUSE (T3.15AL250V)	RT62	DISCHARGE TEMP. THERMISTOR		
IC700,IC932	POWER MODULE	RT64	FIN TEMP. THERMISTOR		
L	REACTOR	RT65	AMBIENT TEMP. THERMISTOR		

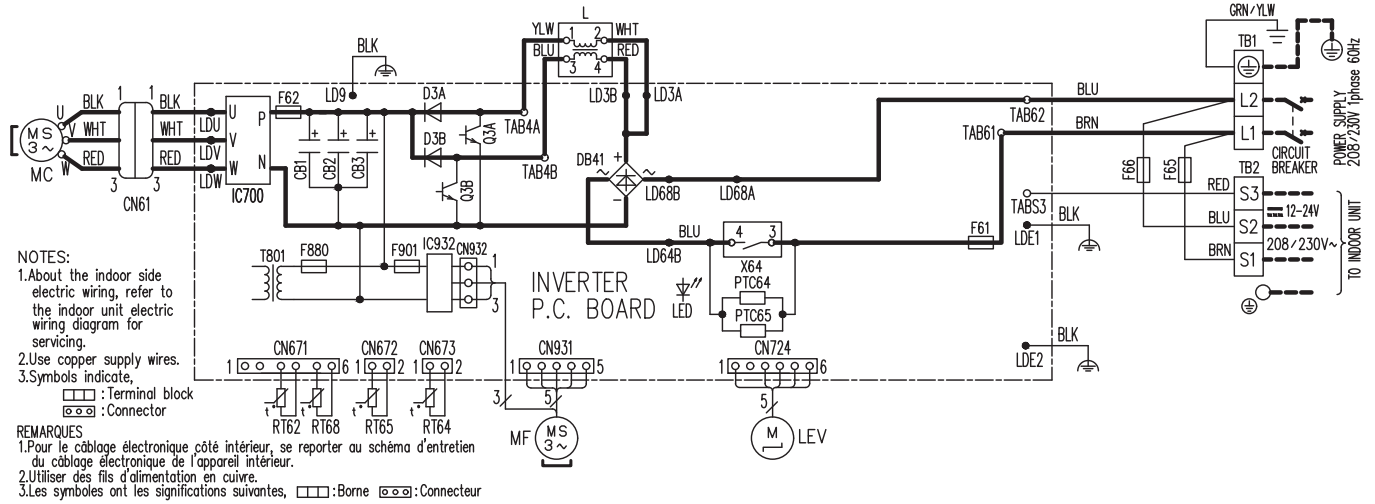
## MUZ-GS30NAH MUZ-GS36NAH



SYMBOL	NAME	SYMBOL	NAME	SYMBOL	NAME
CB1,CB2,CB3	SMOOTHING CAPACITOR	L	REACTOR	RT65	AMBIENT TEMP. THERMISTOR
CN61	CONNECTOR	LED	LED	RT68	OUTDOOR HEAT EXCHANGER TEMP. THERMISTOR
DB41	DIODE MODULE	LEV	EXPANSION VALVE COIL	TB1,TB2	TERMINAL BLOCK
D3A,D3B	DIODE	MC	COMPRESSOR	T801	TRANSFORMER
F61	FUSE (25A 250V)	MF	FAN MOTOR	X64,X601,X602	RELAY
F62	FUSE (15A 250V)	PTC64,PTC65	CIRCUIT PROTECTION	21S4	REVERSING VALVE COIL
F65,F66	FUSE (T6.3AL250V)	Q3A,Q3B	SWITCHING POWER TRANSISTOR	26H	HEATER PROTECTOR
F601,F880,F901	FUSE (T3.15AL250V)	RT61	DEFROST TEMP. THERMISTOR		
H	DEFROST HEATER	RT62	DISCHARGE TEMP. THERMISTOR		
IC700,IC932	POWER MODULE	RT64	FIN TEMP. THERMISTOR		

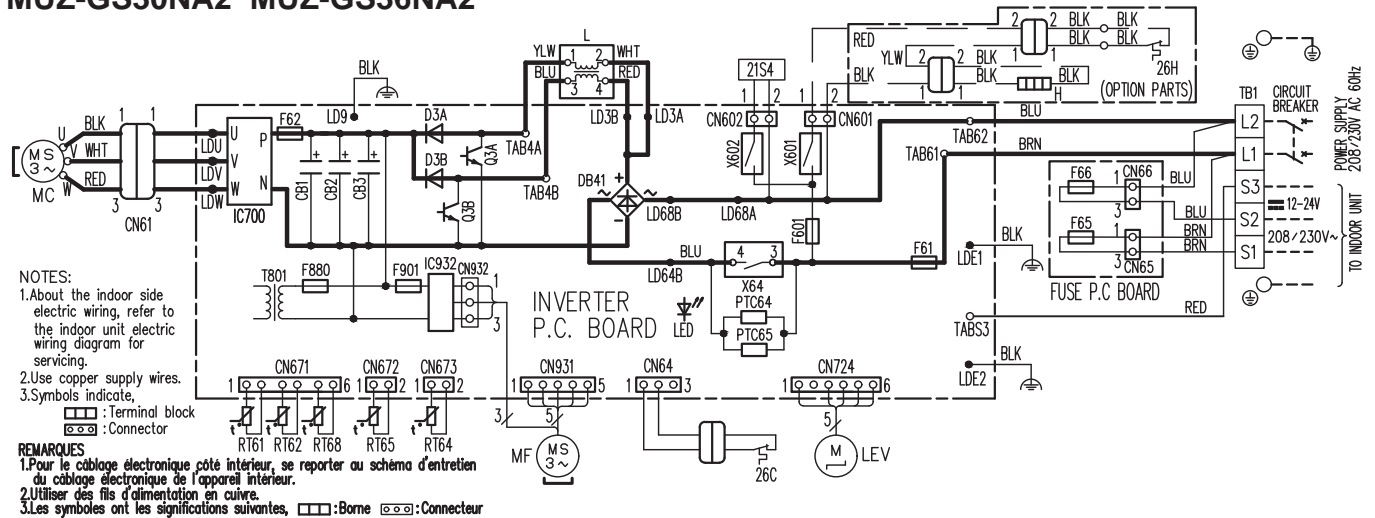


## MUY-GS30NA MUY-GS36NA



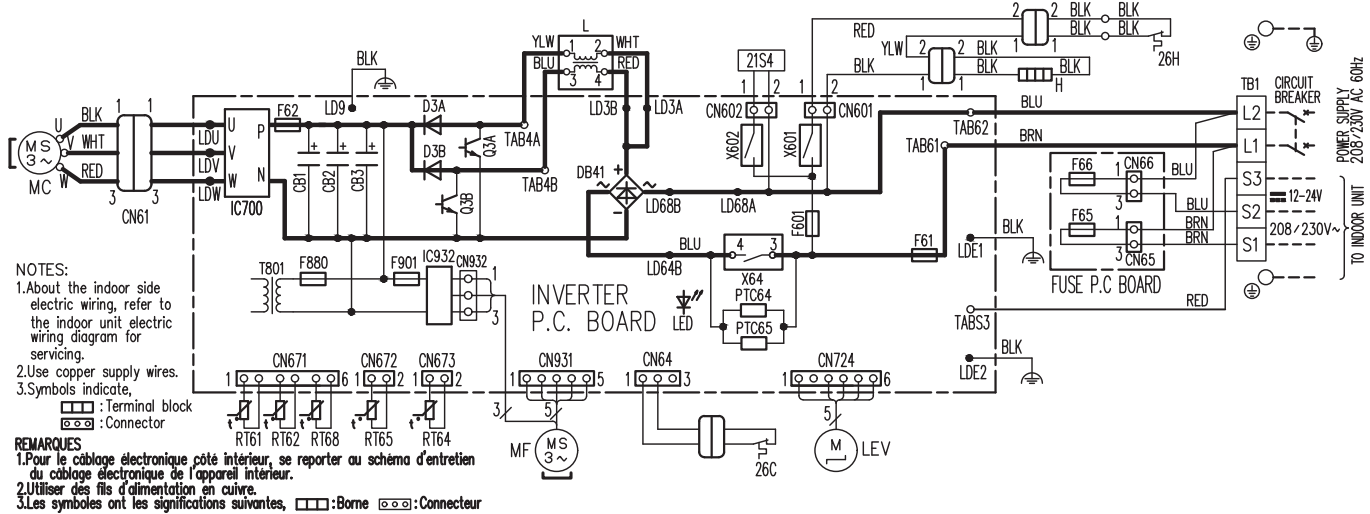
SYMBOL	NAME	SYMBOL	NAME	SYMBOL	NAME
CB1, CB2, CB3	SMOOTHING CAPACITOR	L	REACTOR	RT65	AMBIENT TEMP. THERMISTOR
CN61	CONNECTOR	LED	LED	RT68	OUTDOOR HEAT EXCHANGER TEMP. THERMISTOR
DB41	DIODE MODULE	LEV	EXPANSION VALVE COIL	TB1, TB2	TERMINAL BLOCK
D3A, D3B	DIODE	MC	COMPRESSOR	T801	TRANSFORMER
F61	FUSE (25A 250V)	MF	FAN MOTOR	X64	RELAY
F62	FUSE (15A 250V)	PTC64, PTC65	CIRCUIT PROTECTION		
F65, F66	FUSE (T6.3AL250V)	Q3A, Q3B	SWITCHING POWER TRANSISTOR		
F880, F901	FUSE (T3.15AL250V)	RT62	DISCHARGE TEMP. THERMISTOR		
IC700, IC932	POWER MODULE	RT64	FIN TEMP. THERMISTOR		

## MUZ-GS30NA2 MUZ-GS36NA2



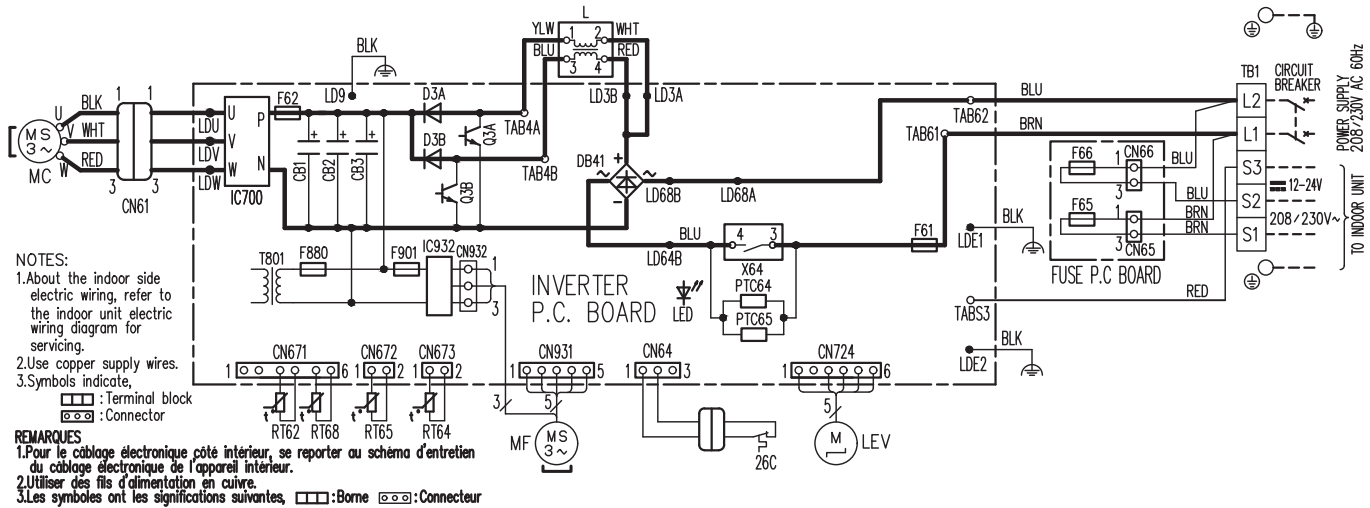
SYMBOL	NAME	SYMBOL	NAME	SYMBOL	NAME
CB1, CB2, CB3	SMOOTHING CAPACITOR	L	REACTOR	RT65	AMBIENT TEMP. THERMISTOR
CN61	CONNECTOR	LED	LED	RT68	OUTDOOR HEAT EXCHANGER TEMP. THERMISTOR
DB41	DIODE MODULE	LEV	EXPANSION VALVE COIL	TB1	TERMINAL BLOCK
D3A, D3B	DIODE	MC	COMPRESSOR	T801	TRANSFORMER
F61	FUSE (25A 250V)	MF	FAN MOTOR	X64, X601, X602	RELAY
F62	FUSE (15A 250V)	PTC64, PTC65	CIRCUIT PROTECTION	21S4	REVERSING VALVE COIL
F65, F66	FUSE (T6.3AL250V)	Q3A, Q3B	SWITCHING POWER TRANSISTOR	26C	COMPRESSOR PROTECTOR
F601, F880, F901	FUSE (T3.15AL250V)	RT61	DEFROST TEMP. THERMISTOR	26H	HEATER PROTECTOR (OPTION PARTS)
H	DEFROST HEATER	RT62	DISCHARGE TEMP. THERMISTOR		
IC700, IC932	POWER MODULE	RT64	FIN TEMP. THERMISTOR		

## MUZ-GS30NAH2 MUZ-GS36NAH2



SYMBOL	NAME	SYMBOL	NAME	SYMBOL	NAME
CB1,CB2,CB3	SMOOTHING CAPACITOR	L	REACTOR	RT65	AMBIENT TEMP. THERMISTOR
CN61	CONNECTOR	LED	LED	RT68	OUTDOOR HEAT EXCHANGER TEMP. THERMISTOR
DB41	DIODE MODULE	LEV	EXPANSION VALVE COIL	TB1	TERMINAL BLOCK
D3A,D3B	DIODE	MC	COMPRESSOR	T801	TRANSFORMER
F61	FUSE (25A 250V)	MF	FAN MOTOR	X64,X601,X602	RELAY
F62	FUSE (15A 250V)	PTC64,PTC65	CIRCUIT PROTECTION	21S4	REVERSING VALVE COIL
F65,F66	FUSE (T6.3AL250V)	Q3A,Q3B	SWITCHING POWER TRANSISTOR	26C	COMPRESSOR PROTECTOR
F601,F880,F901	FUSE (T3.15AL250V)	RT61	DEFROST TEMP. THERMISTOR	26H	HEATER PROTECTOR
H	DEFROST HEATER	RT62	DISCHARGE TEMP. THERMISTOR		
IC700,IC932	POWER MODULE	RT64	FIN TEMP. THERMISTOR		

## MUY-GS30NA2 MUY-GS36NA2



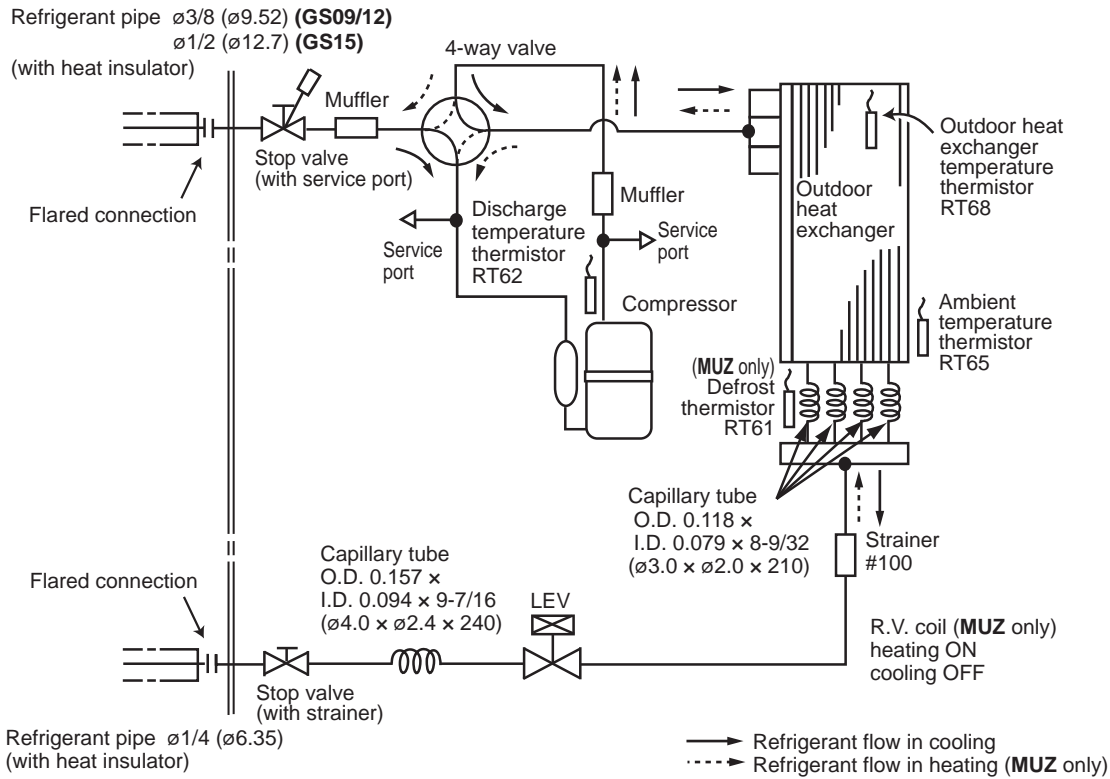
SYMBOL	NAME	SYMBOL	NAME	SYMBOL	NAME
CB1,CB2,CB3	SMOOTHING CAPACITOR	L	REACTOR	RT65	AMBIENT TEMP. THERMISTOR
CN61	CONNECTOR	LED	LED	RT68	OUTDOOR HEAT EXCHANGER TEMP. THERMISTOR
DB41	DIODE MODULE	LEV	EXPANSION VALVE COIL	TB1	TERMINAL BLOCK
D3A,D3B	DIODE	MC	COMPRESSOR	T801	TRANSFORMER
F61	FUSE (25A 250V)	MF	FAN MOTOR	X64	RELAY
F62	FUSE (15A 250V)	PTC64,PTC65	CIRCUIT PROTECTION	26C	COMPRESSOR PROTECTOR
F65,F66	FUSE (T6.3AL250V)	Q3A,Q3B	SWITCHING POWER TRANSISTOR		
F880,F901	FUSE (T3.15AL250V)	RT62	DISCHARGE TEMP. THERMISTOR		
IC700,IC932	POWER MODULE	RT64	FIN TEMP. THERMISTOR		

6

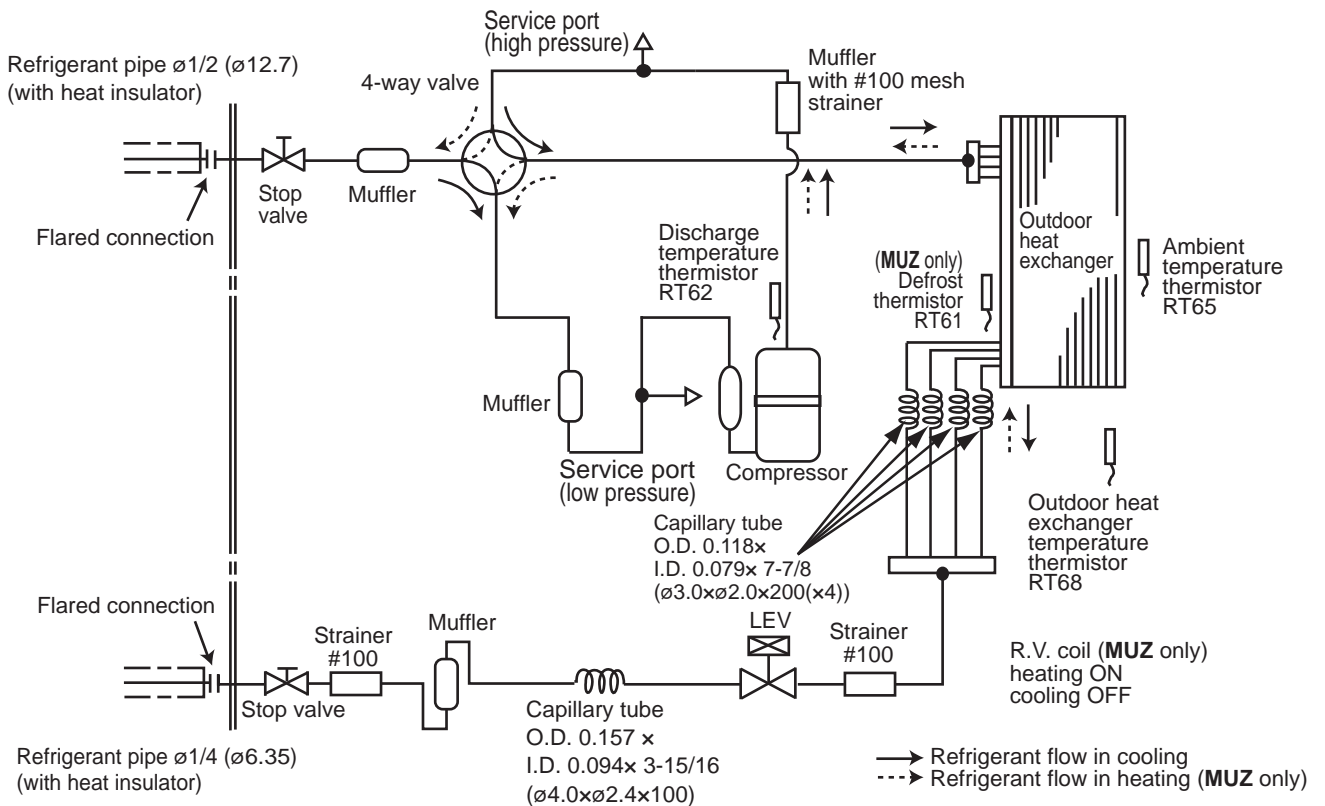
REFRIGERANT SYSTEM DIAGRAM

MUZ-GS09NA MUZ-GS09NAH MUZ-GS09NAHZ MUY-GS09NA  
 MUZ-GS12NA MUZ-GS12NAH MUZ-GS12NAHZ MUY-GS12NA  
 MUZ-GS15NA MUZ-GS15NAH MUZ-GS15NAHZ MUY-GS15NA

Unit: Inch (mm)

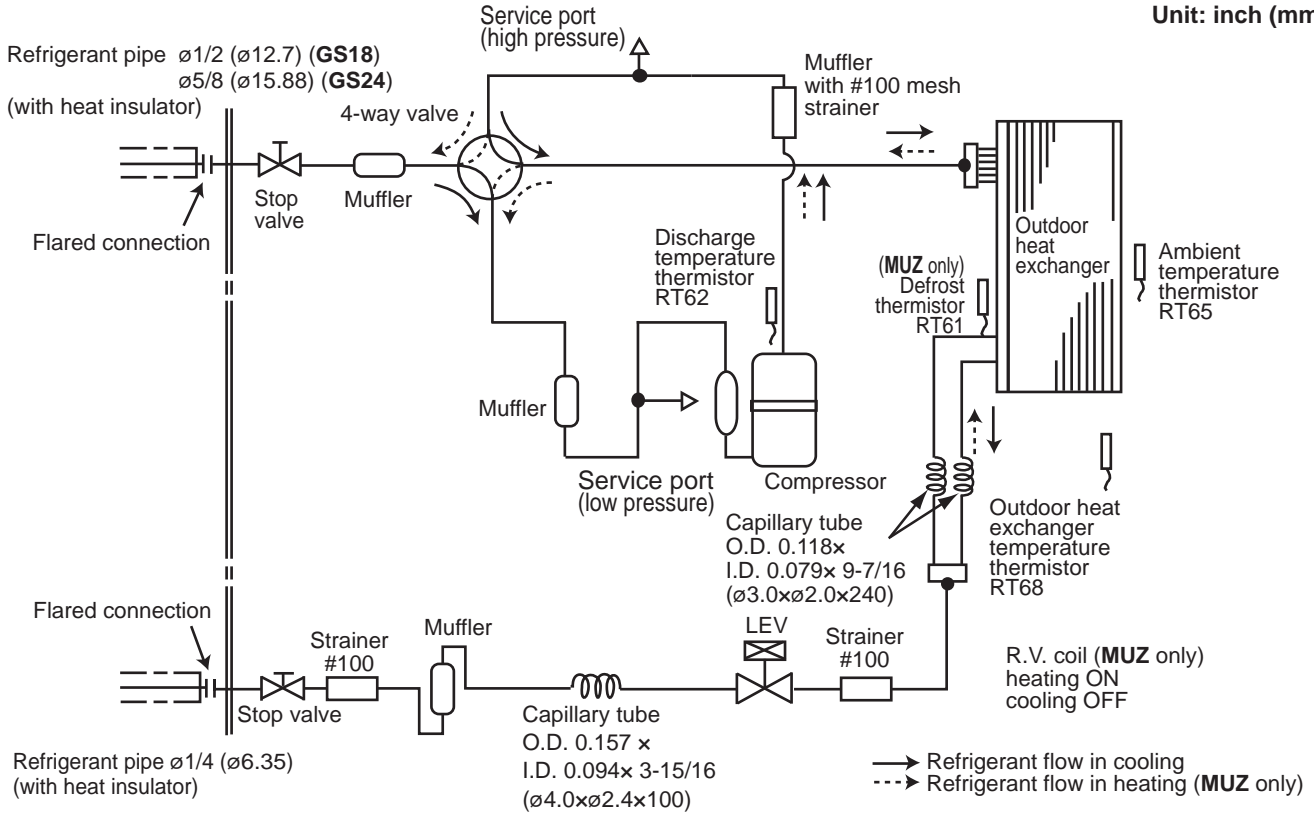


MUZ-GS18NA MUZ-GS18NAH MUY-GS18NA

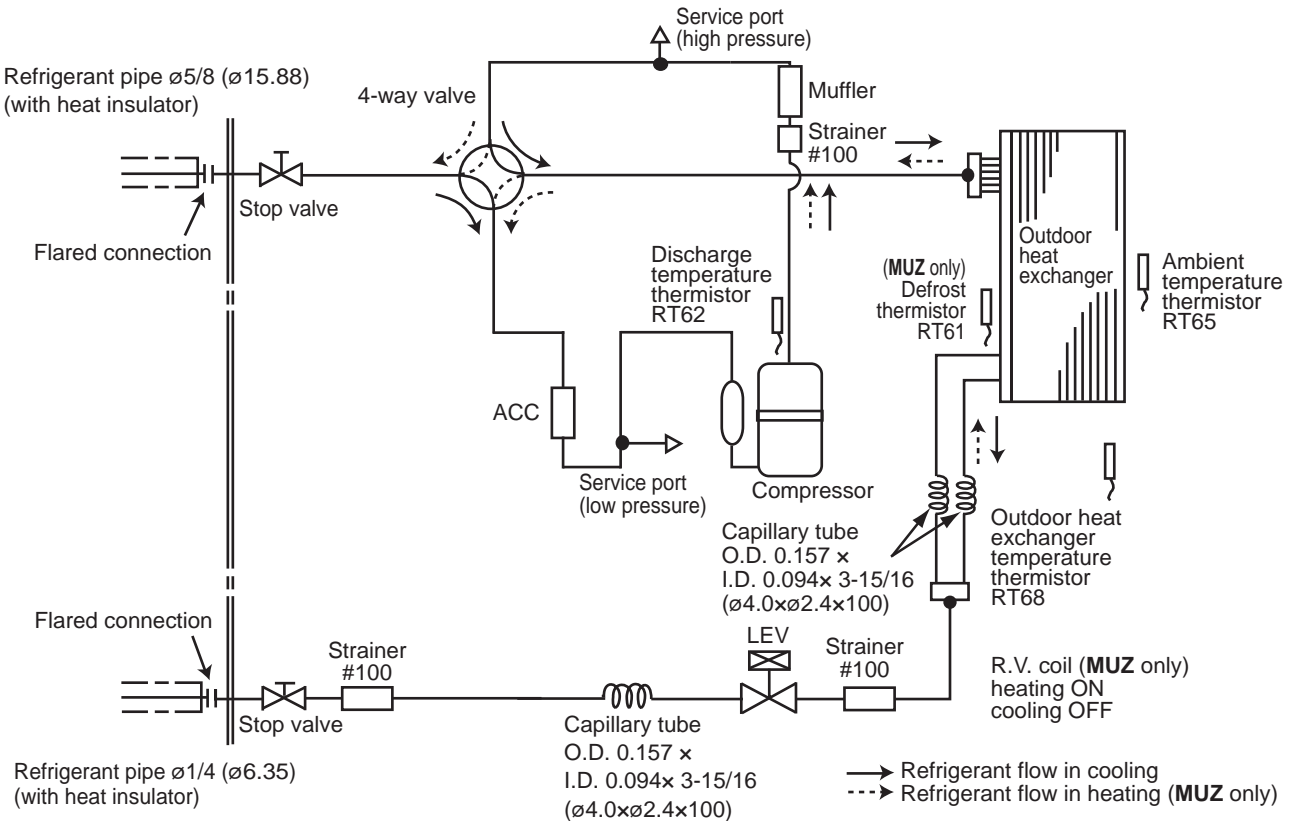


**MUZ-GS18NAHZ MUZ-GS24NA MUZ-GS24NAH MUZ-GS24NAHZ MUY-GS24NA**

Unit: inch (mm)

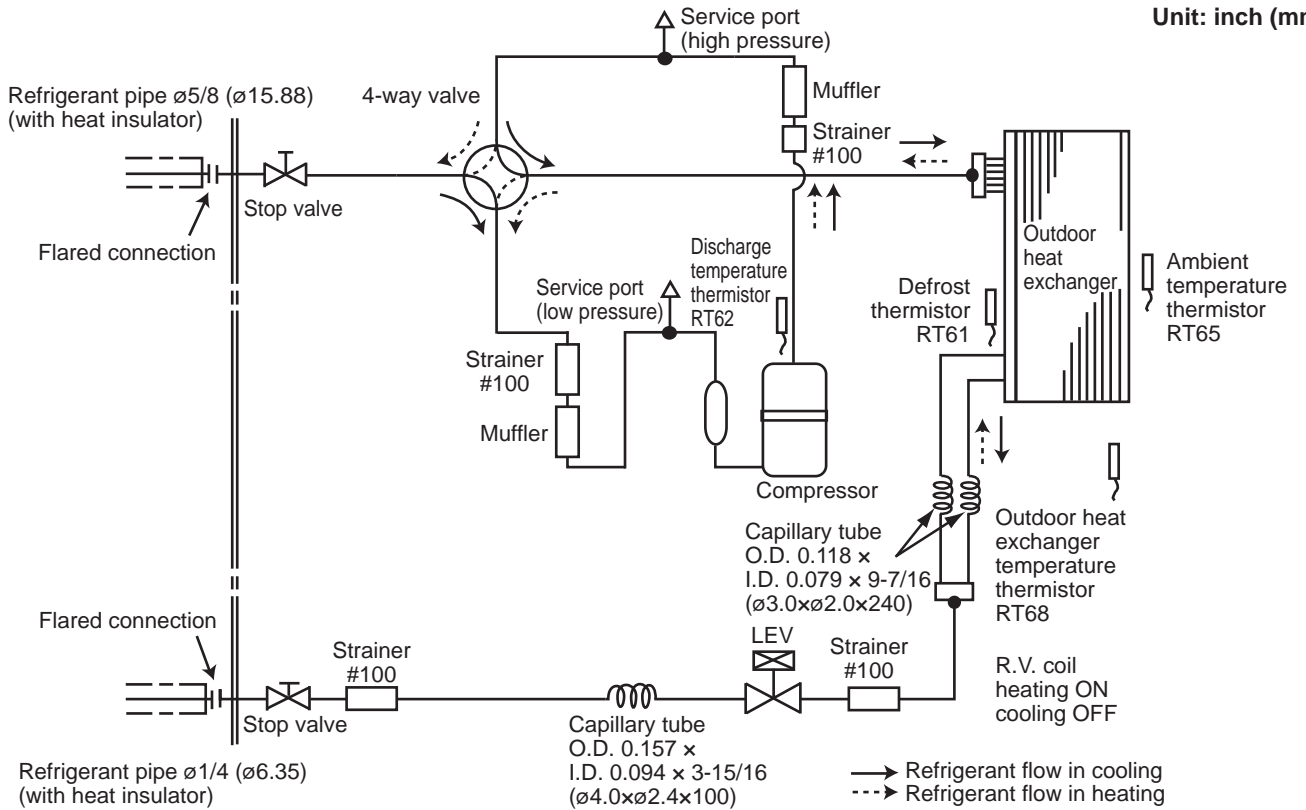


**MUZ-GS30NA MUZ-GS30NAH MUZ-GS36NA MUZ-GS36NAH MUY-GS30NA MUY-GS36NA**

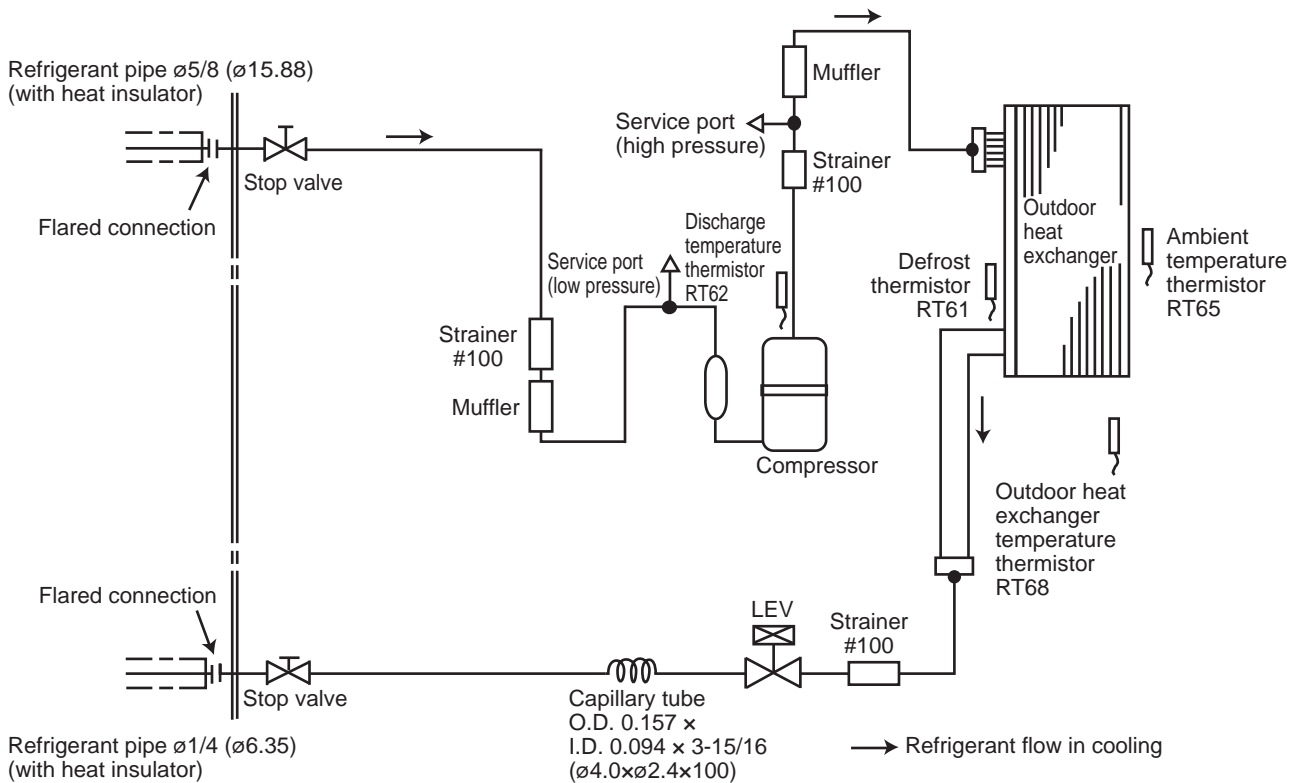


**MUZ-GS30NA2 MUZ-GS30NAH2 MUZ-GS36NA2 MUZ-GS36NAH2**

Unit: inch (mm)

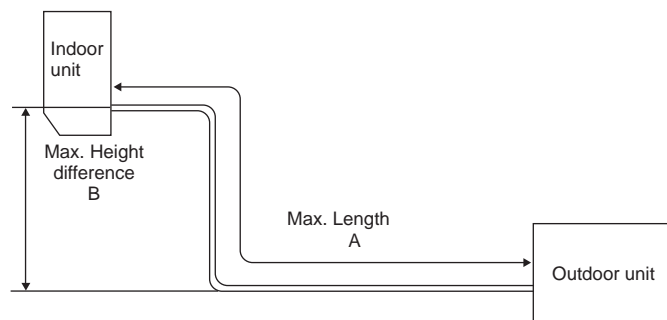


**MUY-GS30NA2 MUY-GS36NA2**



## MAX. REFRIGERANT PIPING LENGTH and MAX. HEIGHT DIFFERENCE

Model	Refrigerant piping: ft.		Piping size O.D: in.	
	Max. Length A	Max. Height difference B	Gas	Liquid
MUZ-GS09NA MUZ-GS09NAH MUZ-GS09NAHZ MUY-GS09NA MUZ-GS12NA MUZ-GS12NAH MUZ-GS12NAHZ MUY-GS12NA	65	40	3/8	1/4
MUZ-GS15NA MUZ-GS15NAH MUZ-GS15NAHZ MUY-GS15NA	65	40	1/2	1/4
MUZ-GS18NA MUZ-GS18NAH MUZ-GS18NAHZ MUY-GS18NA	100	50	1/2	1/4
MUZ-GS24NA MUZ-GS24NAH MUZ-GS24NAHZ MUY-GS24NA MUZ-GS30NA MUZ-GS30NAH MUZ-GS30NA2 MUZ-GS30NAH2 MUY-GS30NA MUY-GS30NA2 MUZ-GS36NA MUZ-GS36NAH MUZ-GS36NA2 MUZ-GS36NAH2 MUY-GS36NA MUY-GS36NA2	100	50	5/8	1/4



### ADDITIONAL REFRIGERANT CHARGE (R410A: oz.)

**NOTE:** Refrigerant piping exceeding 25 ft. requires additional refrigerant charge according to the calculation.

Model	Outdoor unit precharged	Refrigerant piping length (one way): ft.					
		25	30	40	50	60	65
MUZ-GS09NA MUZ-GS09NAH MUZ-GS09NAHZ MUY-GS09NA MUZ-GS12NA MUZ-GS12NAH MUZ-GS12NAHZ MUY-GS12NA MUZ-GS15NA MUZ-GS15NAH MUZ-GS15NAHZ MUY-GS15NA	2 lb. 9 oz.	0	1.08	3.24	5.40	7.56	8.64

Calculation: X oz. = 1.08/5 oz./ft. × (Refrigerant piping length (ft.) - 25)

**NOTE:** Refrigerant piping exceeding 25 ft. requires additional refrigerant charge according to the calculation.

Model	Outdoor unit precharged	Refrigerant piping length (one way): ft.								
		25	30	40	50	60	70	80	90	100
MUZ-GS18NA MUZ-GS18NAH MUZ-GS18NAHZ MUY-GS18NA	3 lb. 7 oz.	0	1.08	3.24	5.40	7.56	9.72	11.88	14.04	16.20
MUZ-GS24NA MUZ-GS24NAH MUZ-GS24NAHZ MUY-GS24NA	4 lb. 5 oz.									
MUZ-GS30NA MUZ-GS30NAH MUY-GS30NA MUZ-GS36NA MUZ-GS36NAH MUY-GS36NA	4 lb. 0 oz.									
MUZ-GS30NA2 MUZ-GS30NAH2 MUY-GS30NA2 MUZ-GS36NA2 MUZ-GS36NAH2 MUY-GS36NA2	4 lb. 5 oz.									

Calculation: X oz. = 1.08/5 oz./ft. × (Refrigerant piping length (ft.) - 25)



**MUZ-GS09NA MUZ-GS09NAH MUZ-GS09NAHZ MUY-GS09NA**  
**MUZ-GS12NA MUZ-GS12NAH MUZ-GS12NAHZ MUY-GS12NA**  
**MUZ-GS15NA MUZ-GS15NAH MUZ-GS15NAHZ MUY-GS15NA**  
**MUZ-GS18NA MUZ-GS18NAH MUZ-GS18NAHZ MUY-GS18NA**  
**MUZ-GS24NA MUZ-GS24NAH MUZ-GS24NAHZ MUY-GS24NA**  
**MUZ-GS30NA MUZ-GS30NAH MUY-GS30NA MUZ-GS30NA2 MUZ-GS30NAH2 MUY-GS30NA2**  
**MUZ-GS36NA MUZ-GS36NAH MUY-GS36NA MUZ-GS36NA2 MUZ-GS36NAH2 MUY-GS36NA2**

### 7-1. PERFORMANCE DATA

#### 1) COOLING CAPACITY

Model	Indoor air IWB (°F)	Outdoor intake air DB temperature (°F)											
		75				85				95			
		TC	SHC	SHF	TPC	TC	SHC	SHF	TPC	TC	SHC	SHF	TPC
<b>MUZ-GS09NA</b>	71	11.0	8.5	0.77	0.52	10.3	7.9	0.77	0.57	9.7	7.4	0.77	0.61
<b>MUZ-GS09NAH</b>	67	10.4	9.4	0.90	0.49	9.7	8.7	0.90	0.54	9.0	8.1	0.90	0.59
<b>MUY-GS09NA</b>	63	9.8	10.1	1.03	0.47	9.1	9.4	1.03	0.52	8.5	8.7	1.03	0.56
<b>MUZ-GS09NAHZ</b>	63	9.8	10.1	1.03	0.47	9.1	9.4	1.03	0.52	8.5	8.7	1.03	0.56
<b>MUZ-GS12NA</b>	71	14.7	9.4	0.64	0.82	13.7	8.7	0.64	0.90	12.9	8.2	0.64	0.97
<b>MUZ-GS12NAH</b>	67	13.9	10.7	0.77	0.77	13.0	10.0	0.77	0.85	12.0	9.2	0.77	0.92
<b>MUY-GS12NA</b>	63	13.1	11.8	0.90	0.74	12.1	10.9	0.90	0.81	11.3	10.2	0.90	0.88
<b>MUZ-GS12NAHZ</b>	63	13.1	11.8	0.90	0.74	12.1	10.9	0.90	0.81	11.3	10.2	0.90	0.88
<b>MUZ-GS15NA</b>	71	17.2	11.4	0.67	0.98	16.0	10.7	0.67	1.07	15.1	10.0	0.67	1.16
<b>MUZ-GS15NAH</b>	67	16.2	13.0	0.80	0.92	15.1	12.1	0.80	1.02	14.0	11.2	0.80	1.10
<b>MUY-GS15NA</b>	63	15.3	14.2	0.93	0.88	14.1	13.2	0.93	0.97	13.2	12.3	0.93	1.05
<b>MUZ-GS15NAHZ</b>	63	15.3	14.2	0.93	0.88	14.1	13.2	0.93	0.97	13.2	12.3	0.93	1.05
<b>MUZ-GS18NA</b>	71	22.1	14.0	0.64	1.19	20.6	13.1	0.64	1.31	19.4	12.3	0.64	1.41
<b>MUZ-GS18NAH</b>	67	20.9	16.1	0.77	1.13	19.4	15.0	0.77	1.24	18.0	13.9	0.77	1.34
<b>MUY-GS18NA</b>	63	19.6	17.7	0.90	1.07	18.2	16.4	0.90	1.19	16.9	15.3	0.90	1.28
<b>MUZ-GS18NAHZ</b>	63	19.6	17.7	0.90	1.07	18.2	16.4	0.90	1.19	16.9	15.3	0.90	1.28
<b>MUZ-GS24NA</b>	71	27.6	17.0	0.62	1.60	25.8	15.9	0.62	1.76	24.2	14.9	0.62	1.89
<b>MUZ-GS24NAH</b>	67	26.1	19.6	0.75	1.51	24.3	18.2	0.75	1.67	22.5	16.9	0.75	1.80
<b>MUY-GS24NA</b>	63	24.5	21.7	0.88	1.44	22.7	20.1	0.88	1.59	21.2	18.7	0.88	1.72
<b>MUZ-GS24NAHZ</b>	63	24.5	21.7	0.88	1.44	22.7	20.1	0.88	1.59	21.2	18.7	0.88	1.72
<b>MUZ-GS30NA</b>	71	37.6	22.1	0.59	2.95	35.2	20.6	0.59	3.24	33.0	19.4	0.59	3.49
<b>MUZ-GS30NAH</b>	67	35.6	25.6	0.72	2.79	33.2	23.9	0.72	3.07	30.7	22.1	0.72	3.32
<b>MUY-GS30NA</b>	63	33.5	28.6	0.85	2.66	31.0	26.5	0.85	2.94	28.9	24.6	0.85	3.17
<b>MUZ-GS30NA2</b>	71	37.5	22.0	0.59	2.95	35.0	20.6	0.59	3.24	32.9	19.3	0.59	3.49
<b>MUZ-GS30NAH2</b>	67	35.5	25.6	0.72	2.79	33.0	23.8	0.72	3.07	30.6	22.0	0.72	3.32
<b>MUY-GS30NA2</b>	63	33.4	28.5	0.85	2.66	30.9	26.4	0.85	2.94	28.8	24.5	0.85	3.17
<b>MUZ-GS36NA</b>	71	39.2	21.8	0.56	3.23	36.6	20.4	0.56	3.54	34.4	19.1	0.56	3.81
<b>MUZ-GS36NAH</b>	67	37.1	25.6	0.69	3.05	34.6	23.8	0.69	3.36	32.0	22.1	0.69	3.63
<b>MUY-GS36NA</b> (208V)	63	34.9	28.7	0.82	2.90	32.3	26.6	0.82	3.21	30.1	24.8	0.82	3.47
<b>MUZ-GS36NA</b>	71	40.7	22.6	0.56	3.36	38.0	21.2	0.56	3.68	35.7	19.9	0.56	3.96
<b>MUZ-GS36NAH</b>	67	38.5	26.6	0.69	3.17	35.9	24.7	0.69	3.49	33.2	22.9	0.69	3.77
<b>MUY-GS36NA</b> (230V)	63	36.2	29.8	0.82	3.02	33.5	27.6	0.82	3.34	31.2	25.7	0.82	3.60
<b>MUZ-GS36NA2</b>	71	40.7	22.6	0.56	3.36	38.0	21.2	0.56	3.68	35.7	19.9	0.56	3.96
<b>MUZ-GS36NAH2</b>	67	38.5	26.6	0.69	3.17	35.9	24.7	0.69	3.49	33.2	22.9	0.69	3.77
<b>MUY-GS36NA2</b>	63	36.2	29.8	0.82	3.02	33.5	27.6	0.82	3.34	31.2	25.7	0.82	3.60

**NOTE:** 1. IWB : Intake air wet-bulb temperature      TC : Total Capacity (x10<sup>3</sup> Btu/h)  
 SHC : Sensible Heat Capacity (x10<sup>3</sup> Btu/h)      SHF : Sensible Heat Factor  
 TPC : Total Power Consumption (kW)  
 2. SHC is based on 80°F of indoor Intake air DB temperature.

Model	Indoor air		Outdoor intake air DB temperature (°F)						
	IWB (°F)	105				115			
		TC	SHC	SHF	TPC	TC	SHC	SHF	TPC
MUZ-GS09NA	71	9.0	6.9	0.77	0.65	8.3	6.3	0.77	0.67
MUZ-GS09NAH	67	8.4	7.5	0.90	0.62	7.7	6.9	0.90	0.65
MUY-GS09NA	63	7.7	8.0	1.03	0.60	7.0	7.3	1.03	0.62
MUZ-GS09NAHZ	63	7.7	8.0	1.03	0.60	7.0	7.3	1.03	0.62
MUZ-GS12NA	71	12.0	7.6	0.64	1.02	11.0	7.0	0.64	1.06
MUZ-GS12NAH	67	11.2	8.6	0.77	0.98	10.3	7.9	0.77	1.02
MUY-GS12NA	63	10.3	9.3	0.90	0.94	9.4	8.5	0.90	0.98
MUZ-GS12NAHZ	63	10.3	9.3	0.90	0.94	9.4	8.5	0.90	0.98
MUZ-GS15NA	71	14.0	9.3	0.67	1.22	12.9	8.6	0.67	1.27
MUZ-GS15NAH	67	13.0	10.4	0.80	1.17	12.0	9.6	0.80	1.22
MUY-GS15NA	63	12.0	11.2	0.93	1.12	10.9	10.2	0.93	1.17
MUZ-GS15NAHZ	63	12.0	11.2	0.93	1.12	10.9	10.2	0.93	1.17
MUZ-GS18NA	71	18.0	11.5	0.64	1.48	16.6	10.5	0.64	1.54
MUZ-GS18NAH	67	16.7	12.9	0.77	1.42	15.4	11.9	0.77	1.49
MUY-GS18NA	63	15.4	13.9	0.90	1.37	14.0	12.7	0.90	1.42
MUZ-GS18NAHZ	63	15.4	13.9	0.90	1.37	14.0	12.7	0.90	1.42
MUZ-GS24NA	71	22.5	13.9	0.62	1.99	20.7	12.8	0.62	2.07
MUZ-GS24NAH	67	20.9	15.7	0.75	1.91	19.2	14.4	0.75	2.00
MUY-GS24NA	63	19.2	17.0	0.88	1.84	17.6	15.5	0.88	1.91
MUZ-GS24NAHZ	63	19.2	17.0	0.88	1.84	17.6	15.5	0.88	1.91
MUZ-GS30NA	71	30.7	18.0	0.59	3.67	28.2	16.6	0.59	3.82
MUZ-GS30NAH	67	28.6	20.6	0.72	3.52	26.2	18.9	0.72	3.69
MUY-GS30NA	63	26.2	22.4	0.85	3.39	23.9	20.4	0.85	3.52
MUZ-GS30NA2	71	30.6	18.0	0.59	3.67	28.2	16.5	0.59	3.82
MUZ-GS30NAH2	67	28.5	20.5	0.72	3.52	26.2	18.8	0.72	3.69
MUY-GS30NA2	63	26.2	22.3	0.85	3.39	23.9	20.4	0.85	3.52
MUZ-GS36NA	71	32.0	17.8	0.56	4.01	29.4	16.4	0.56	4.17
MUZ-GS36NAH	67	29.8	20.5	0.69	3.85	27.4	18.9	0.69	4.03
MUY-GS36NA (208V)	63	27.4	22.5	0.82	3.70	25.0	20.6	0.82	3.85
MUZ-GS36NA	71	33.2	18.5	0.56	4.17	30.5	17.0	0.56	4.34
MUZ-GS36NAH	67	30.9	21.3	0.69	4.00	28.4	19.6	0.69	4.18
MUY-GS36NA (230V)	63	28.4	23.4	0.82	3.85	25.9	21.3	0.82	4.00
MUZ-GS36NA2	71	33.2	18.5	0.56	4.17	30.5	17.0	0.56	4.34
MUZ-GS36NAH2	67	30.9	21.3	0.69	4.00	28.4	19.6	0.69	4.18
MUY-GS36NA2	63	28.4	23.4	0.82	3.85	25.9	21.3	0.82	4.00

NOTE: 1. IWB : Intake air wet-bulb temperature      TC : Total Capacity (x10<sup>3</sup> Btu/h)  
SHC : Sensible Heat Capacity (x10<sup>3</sup> Btu/h)      SHF : Sensible Heat Factor  
TPC : Total Power Consumption (kW)  
2. SHC is based on 80°F of indoor Intake air DB temperature.

## 2) COOLING CAPACITY CORRECTIONS

		Refrigerant piping length (one way: ft.)			
		25 (std.)	40	65	100
MUZ-GS09NA MUZ-GS09NAH MUZ-GS09NAHZ MUZ-GS12NA MUZ-GS12NAH MUZ-GS12NAHZ MUZ-GS15NA MUZ-GS15NAH MUZ-GS15NAHZ	MUY-GS09NA MUY-GS12NA MUY-GS15NA	1.0	0.988	0.967	-
MUZ-GS18NA MUZ-GS18NAH MUZ-GS18NAHZ	MUY-GS18NA	1.0	0.985	0.963	0.933
MUZ-GS24NA MUZ-GS24NAH MUZ-GS24NAHZ	MUY-GS24NA	1.0	0.983	0.956	0.921
MUZ-GS30NA MUZ-GS30NAH MUZ-GS30NA2 MUZ-GS30NAH2	MUY-GS30NA MUY-GS30NA2	1.0	0.976	0.937	0.887
MUZ-GS36NA MUZ-GS36NAH MUZ-GS36NA2 MUZ-GS36NAH2	MUY-GS36NA MUY-GS36NA2	1.0	0.974	0.932	0.878

## 3) HEATING CAPACITY CORRECTIONS

Refrigerant piping length (one way: ft.)				
	25 (std.)	40	65	100
MUZ-GS09NA MUZ-GS09NAH MUZ-GS09NAHZ MUZ-GS12NA MUZ-GS12NAH MUZ-GS12NAHZ MUZ-GS15NA MUZ-GS15NAH MUZ-GS15NAHZ	1.0	0.997	0.993	-
MUZ-GS18NA MUZ-GS18NAH MUZ-GS18NAHZ MUZ-GS24NA MUZ-GS24NAH MUZ-GS24NAHZ	1.0	0.977	0.993	0.987
MUZ-GS30NA MUZ-GS30NAH MUZ-GS30NA2 MUZ-GS30NAH2 MUZ-GS36NA MUZ-GS36NAH MUZ-GS36NA2 MUZ-GS36NAH2	1.0	0.997	0.993	0.987

#### 4) HEATING CAPACITY

Model	Indoor air IDB (°F)	Outdoor intake air WB temperature (°F)													
		5		15		25		35		43		45		55	
		TC	TPC	TC	TPC	TC	TPC	TC	TPC	TC	TPC	TC	TPC	TC	TPC
MUZ-GS09NA	75	4.8	0.42	6.3	0.54	7.9	0.63	9.4	0.70	10.6	0.74	11.0	0.75	12.4	0.78
	70	5.2	0.41	6.7	0.52	8.2	0.62	9.6	0.68	10.9	0.72	11.2	0.73	12.7	0.76
	65	5.5	0.39	6.9	0.50	8.6	0.59	10.0	0.67	11.2	0.70	11.6	0.71	13.0	0.75
MUZ-GS09NAH	75	4.8	0.55	6.3	0.67	7.9	0.76	9.4	0.70	10.6	0.74	11.0	0.75	12.4	0.78
	70	5.2	0.54	6.7	0.65	8.2	0.75	9.6	0.68	10.9	0.72	11.2	0.73	12.7	0.76
	65	5.5	0.52	6.9	0.63	8.6	0.72	10.0	0.67	11.2	0.70	11.6	0.71	13.0	0.75
MUZ-GS09NAHZ	75	4.2	0.47	5.6	0.56	7.0	0.64	8.3	0.57	9.4	0.59	9.6	0.60	10.9	0.63
	70	4.6	0.46	5.9	0.55	7.2	0.63	8.5	0.55	9.6	0.58	9.9	0.59	11.2	0.61
	65	4.8	0.44	6.0	0.53	7.5	0.61	8.8	0.54	9.9	0.57	10.2	0.57	11.4	0.60
MUZ-GS12NA	75	6.3	0.65	8.4	0.82	10.4	0.96	12.5	1.07	14.0	1.13	14.5	1.14	16.4	1.19
	70	6.8	0.62	8.9	0.79	10.8	0.94	12.7	1.05	14.4	1.10	14.8	1.12	16.8	1.17
	65	7.2	0.59	9.1	0.76	11.3	0.91	13.2	1.02	14.8	1.07	15.3	1.09	17.1	1.14
MUZ-GS12NAH	75	6.3	0.78	8.4	0.95	10.4	1.09	12.5	1.07	14.0	1.13	14.5	1.14	16.4	1.19
	70	6.8	0.75	8.9	0.92	10.8	1.07	12.7	1.05	14.4	1.10	14.8	1.12	16.8	1.17
	65	7.2	0.72	9.1	0.89	11.3	1.04	13.2	1.02	14.8	1.07	15.3	1.09	17.1	1.14
MUZ-GS12NAHZ	75	5.4	0.62	7.1	0.75	8.9	0.86	10.6	0.81	12.0	0.85	12.4	0.86	14.0	0.90
	70	5.8	0.60	7.6	0.73	9.2	0.84	10.9	0.79	12.3	0.83	12.7	0.85	14.3	0.88
	65	6.2	0.58	7.7	0.70	9.7	0.81	11.3	0.77	12.7	0.81	13.0	0.82	14.6	0.86
MUZ-GS15NA	75	7.9	0.94	10.4	1.19	13.1	1.40	15.6	1.56	17.6	1.64	18.1	1.66	20.5	1.73
	70	8.6	0.90	11.1	1.15	13.5	1.37	15.9	1.52	18.0	1.60	18.5	1.63	21.0	1.70
	65	9.0	0.86	11.3	1.10	14.1	1.32	16.5	1.48	18.5	1.56	19.1	1.58	21.4	1.66
MUZ-GS15NAH	75	7.9	1.07	10.4	1.32	13.1	1.53	15.6	1.56	17.6	1.64	18.1	1.66	20.5	1.73
	70	8.6	1.03	11.1	1.28	13.5	1.50	15.9	1.52	18.0	1.60	18.5	1.63	21.0	1.70
	65	9.0	0.99	11.3	1.23	14.1	1.45	16.5	1.48	18.5	1.56	19.1	1.58	21.4	1.66
MUZ-GS15NAHZ	75	6.2	0.80	8.1	0.98	10.2	1.13	12.1	1.11	13.7	1.17	14.1	1.19	16.0	1.23
	70	6.7	0.77	8.6	0.95	10.5	1.10	12.4	1.08	14.0	1.14	14.4	1.16	16.3	1.21
	65	7.0	0.75	8.8	0.92	11.0	1.07	12.8	1.05	14.4	1.11	14.8	1.13	16.7	1.19
MUZ-GS18NA	75	8.4	0.79	11.0	1.00	13.8	1.17	16.4	1.31	18.5	1.37	19.1	1.39	21.7	1.45
	70	9.0	0.76	11.7	0.96	14.3	1.15	16.8	1.27	19.0	1.34	19.6	1.37	22.1	1.42
	65	9.5	0.72	12.0	0.92	14.9	1.11	17.4	1.24	19.6	1.31	20.1	1.33	22.6	1.39
MUZ-GS18NAH MUZ-GS18NAHZ	75	8.4	0.91	11.0	1.12	13.8	1.29	16.4	1.31	18.5	1.37	19.1	1.39	21.7	1.45
	70	9.0	0.88	11.7	1.08	14.3	1.27	16.8	1.27	19.0	1.34	19.6	1.37	22.1	1.42
	65	9.5	0.84	12.0	1.04	14.9	1.23	17.4	1.24	19.6	1.31	20.1	1.33	22.6	1.39
MUZ-GS24NA	75	12.1	1.38	16.0	1.74	20.0	2.05	23.9	2.28	26.9	2.40	27.7	2.43	31.5	2.53
	70	13.1	1.32	17.0	1.68	20.7	2.00	24.4	2.22	27.6	2.34	28.4	2.39	32.2	2.48
	65	13.8	1.26	17.4	1.61	21.7	1.93	25.3	2.16	28.4	2.28	29.3	2.32	32.8	2.43
MUZ-GS24NAH	75	12.1	1.50	16.0	1.86	20.0	2.17	23.9	2.28	26.9	2.40	27.7	2.43	31.5	2.53
	70	13.1	1.44	17.0	1.80	20.7	2.12	24.4	2.22	27.6	2.34	28.4	2.39	32.2	2.48
	65	13.8	1.38	17.4	1.73	21.7	2.05	25.3	2.16	28.4	2.28	29.3	2.32	32.8	2.43
MUZ-GS24NAHZ	75	9.2	1.02	12.1	1.25	15.1	1.45	18.0	1.48	20.3	1.56	20.9	1.58	23.7	1.64
	70	9.9	0.98	12.8	1.21	15.6	1.42	18.4	1.44	20.8	1.52	21.4	1.55	24.2	1.61
	65	10.4	0.94	13.1	1.17	16.3	1.37	19.0	1.41	21.4	1.48	22.0	1.50	24.8	1.58
MUZ-GS30NA MUZ-GS30NA2	75	14.3	1.97	18.9	2.49	23.6	2.92	28.2	3.26	31.8	3.42	32.8	3.47	37.2	3.61
	70	15.5	1.89	20.0	2.40	24.5	2.86	28.9	3.17	32.6	3.34	33.6	3.41	38.0	3.54
	65	16.3	1.80	20.5	2.30	25.6	2.76	29.8	3.09	33.6	3.26	34.6	3.31	38.8	3.47
MUZ-GS30NAH MUZ-GS30NAH2	75	14.3	2.09	18.9	2.61	23.6	3.04	28.2	3.26	31.8	3.42	32.8	3.47	37.2	3.61
	70	15.5	2.01	20.0	2.52	24.5	2.98	28.9	3.17	32.6	3.34	33.6	3.41	38.0	3.54
	65	16.3	1.92	20.5	2.42	25.6	2.88	29.8	3.09	33.6	3.26	34.6	3.31	38.8	3.47
MUZ-GS36NA MUZ-GS36NA2	75	15.5	2.21	20.4	2.79	25.5	3.27	30.4	3.65	34.3	3.83	35.4	3.89	40.1	4.04
	70	16.7	2.11	21.6	2.69	26.4	3.20	31.2	3.55	35.2	3.74	36.3	3.81	41.0	3.96
	65	17.6	2.02	22.2	2.58	27.6	3.09	32.2	3.46	36.3	3.65	37.3	3.70	41.9	3.89
MUZ-GS36NAH MUZ-GS36NAH2	75	15.5	2.33	20.4	2.91	25.5	3.39	30.4	3.65	34.3	3.83	35.4	3.89	40.1	4.04
	70	16.7	2.23	21.6	2.81	26.4	3.32	31.2	3.55	35.2	3.74	36.3	3.81	41.0	3.96
	65	17.6	2.14	22.2	2.70	27.6	3.21	32.2	3.46	36.3	3.65	37.3	3.70	41.9	3.89

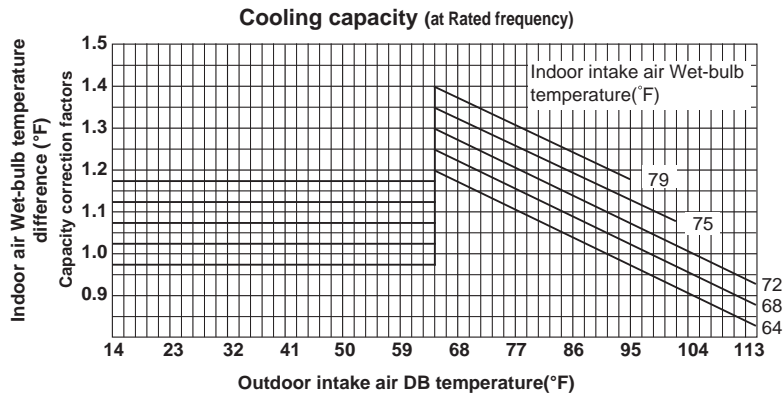
**NOTE:** 1. IDB : Intake air dry-bulb temperature  
 TC : Total Capacity (x10<sup>3</sup> Btu/h)      TPC : Total Power Consumption (kW)  
 2. Above data is for heating operation without any frost.

How to operate with fixed operational frequency of the compressor.

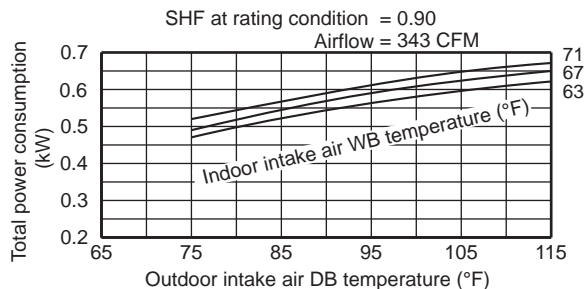
1. Press the emergency operation switch on the front of the indoor unit, and select either EMERGENCY COOL mode or EMERGENCY HEAT mode before starting to operate the air conditioner.
2. The compressor starts with operational frequency.
3. The fan speed of the indoor unit is High.
4. This operation continues for 30 minutes.
5. In order to release this operation, press the emergency operation switch twice or once, or press any button on the remote controller.

## 7-2. PERFORMANCE CURVE

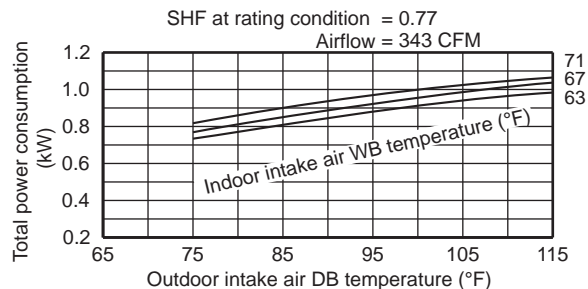
### Cooling



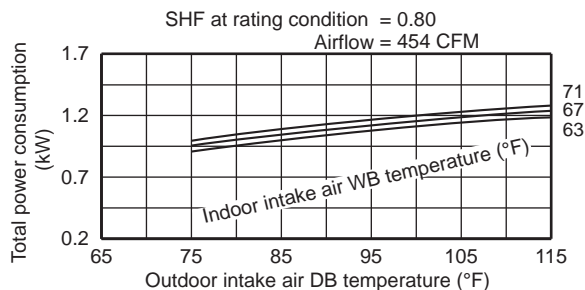
#### MUZ-GS09NA MUZ-GS09NAH MUZ-GS09NAHZ MUY-GS09NA



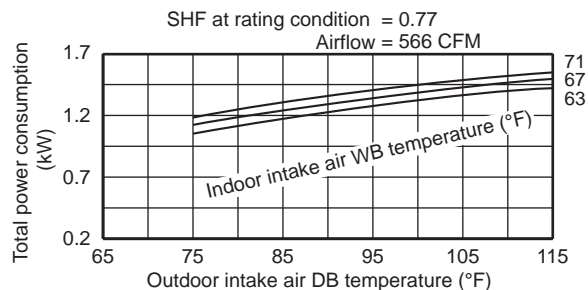
#### MUZ-GS12NA MUZ-GS12NAH MUZ-GS12NAHZ MUY-GS12NA



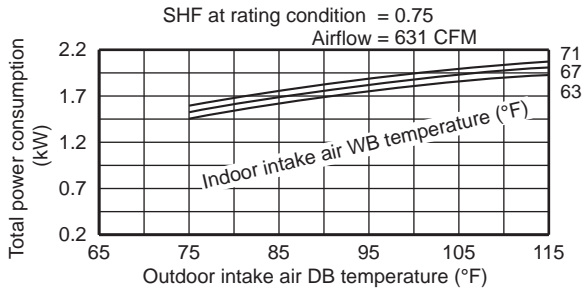
#### MUZ-GS15NA MUZ-GS15NAH MUZ-GS15NAHZ MUY-GS15NA



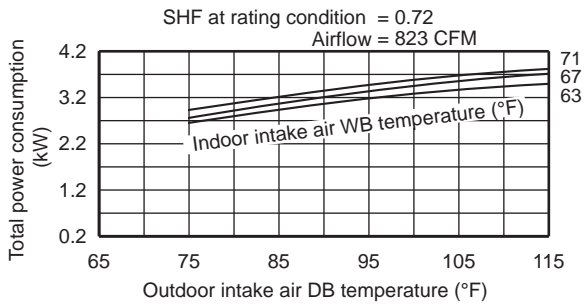
#### MUZ-GS18NA MUZ-GS18NAH MUZ-GS18NAHZ MUY-GS18NA



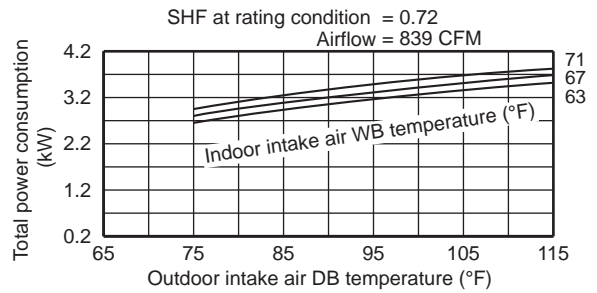
**MUZ-GS24NA MUZ-GS24NAH MUZ-GS24NAHZ  
MUY-GS24NA**



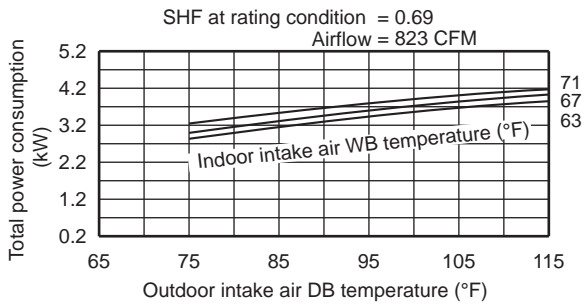
**MUZ-GS30NA MUZ-GS30NAH MUY-GS30NA**



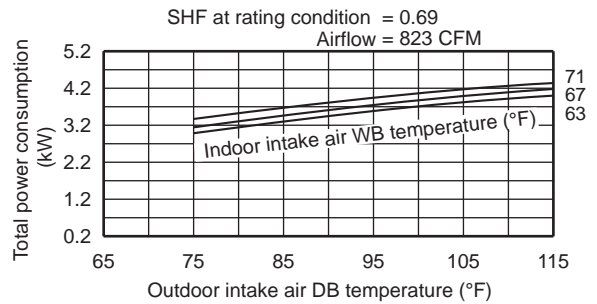
**MUZ-GS30NA2 MUZ-GS30NAH2 MUY-GS30NA2**



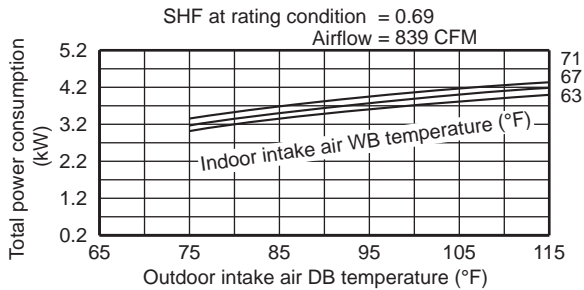
**MUZ-GS36NA MUZ-GS36NAH MUY-GS36NA (208V)**



**MUZ-GS36NA MUZ-GS36NAH MUY-GS36NA (230V)**



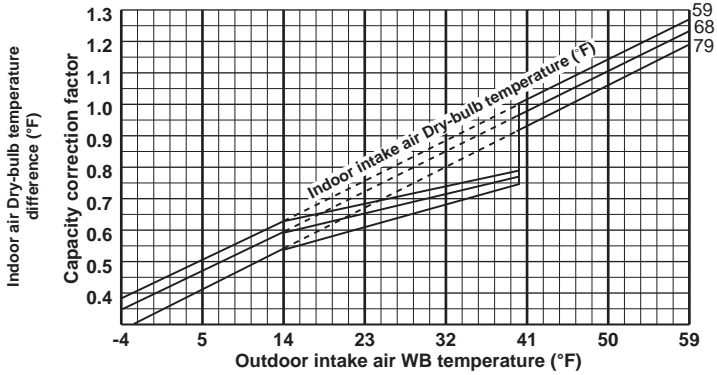
**MUZ-GS36NA2 MUZ-GS36NAH2 MUY-GS36NA2  
MUY-GS36NA2**



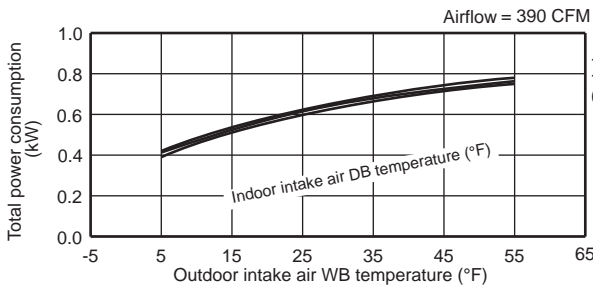
This value of frequency is not the same as the actual frequency in operating. Refer to 7-5 and 7-6 for the relationships between frequency and capacity.

# Heating

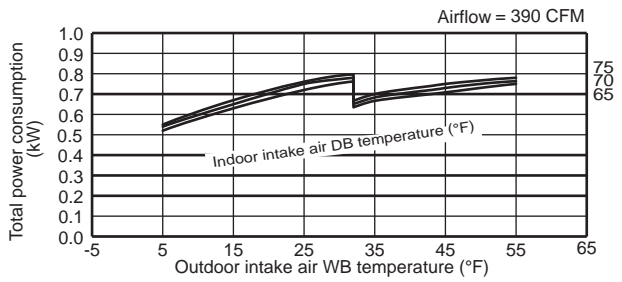
Heating capacity (at Rated frequency)



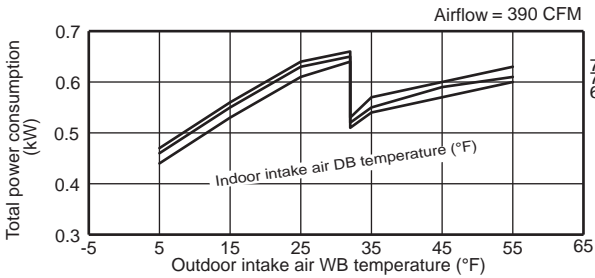
MUZ-GS09NA



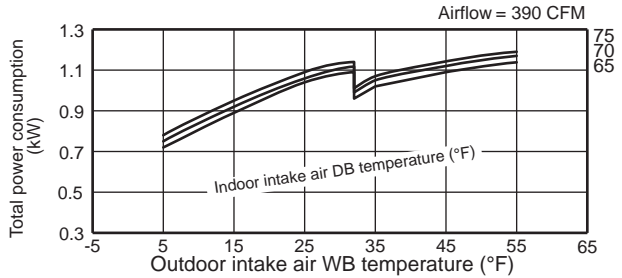
MUZ-GS09NAH



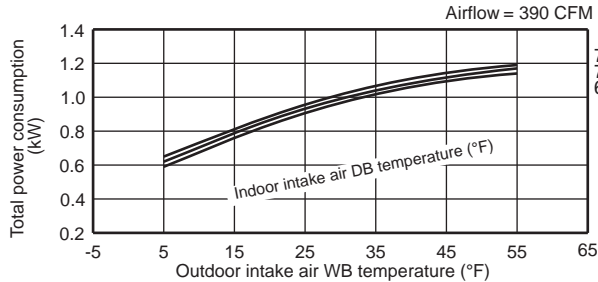
MUZ-GS09NAHZ



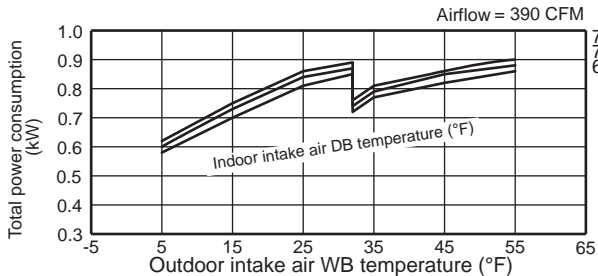
MUZ-GS12NAH



MUZ-GS12NA

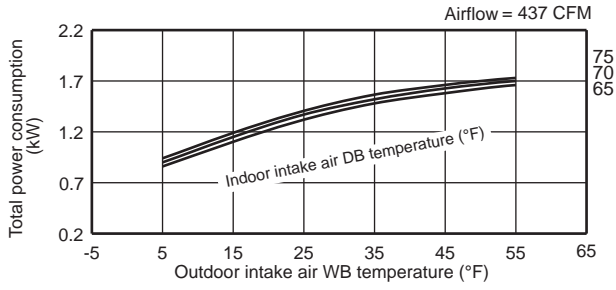


MUZ-GS12NAHZ

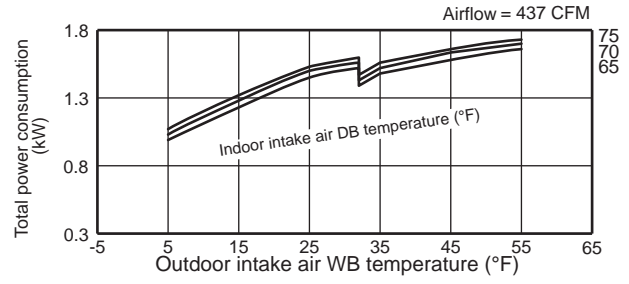




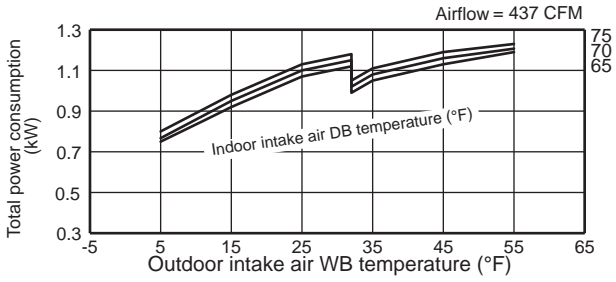
### MUZ-GS15NA



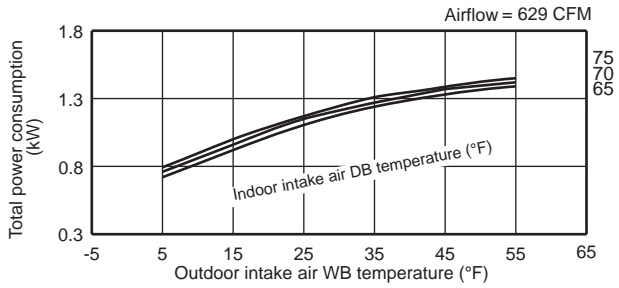
### MUZ-GS15NAH



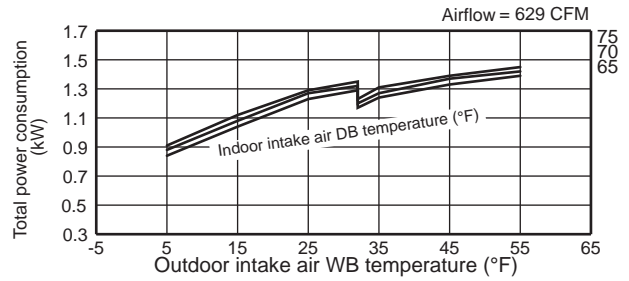
### MUZ-GS15NAHZ



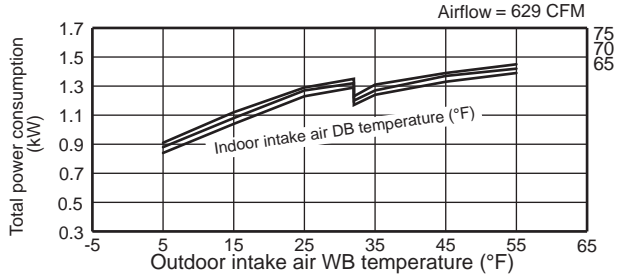
### MUZ-GS18NA



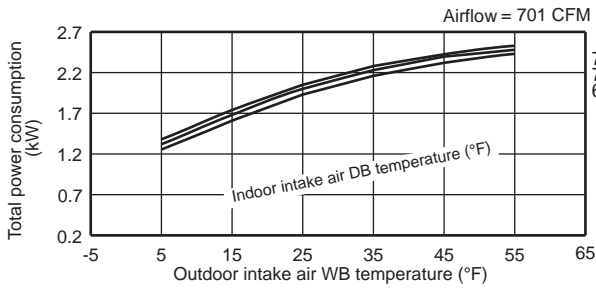
### MUZ-GS18NAH



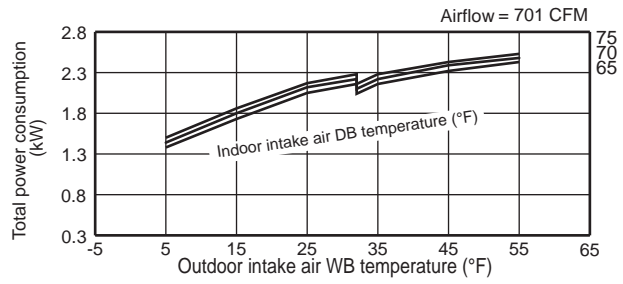
### MUZ-GS18NAHZ



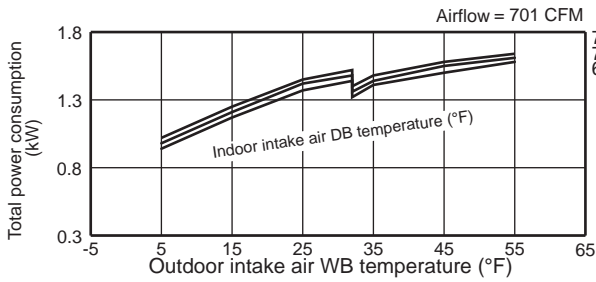
### MUZ-GS24NA



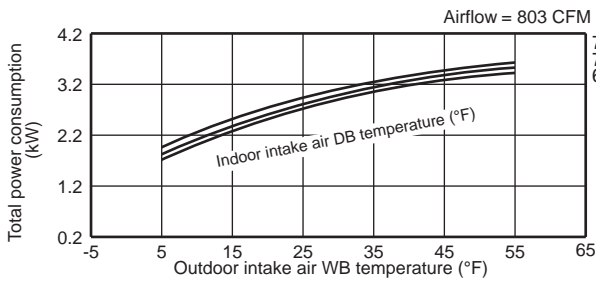
### MUZ-GS24NAH



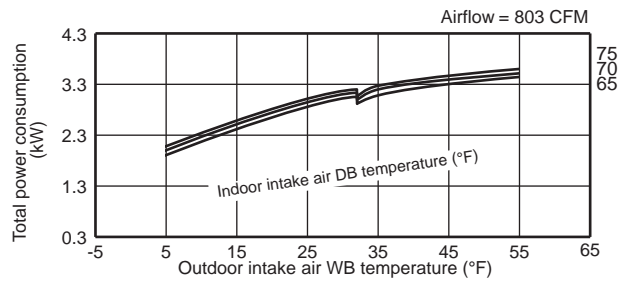
### MUZ-GS24NAHZ



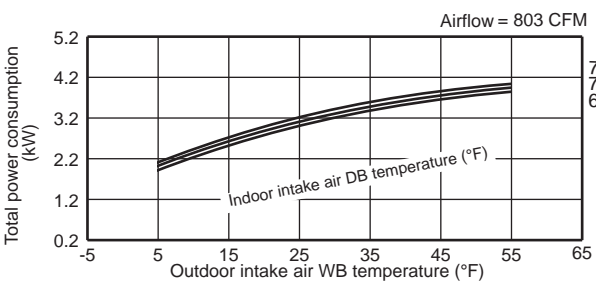
### MUZ-GS30NA



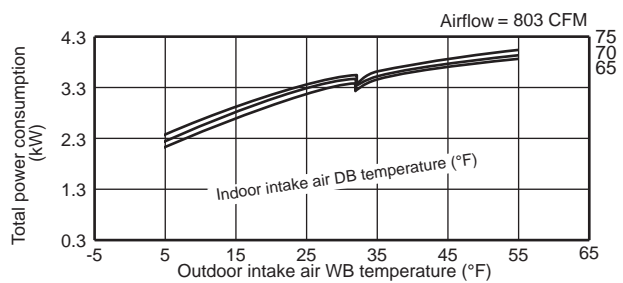
### MUZ-GS30NAH



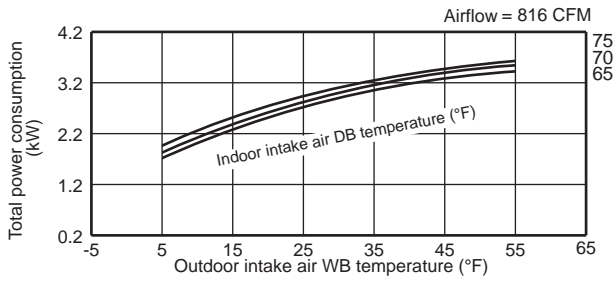
### MUZ-GS36NA



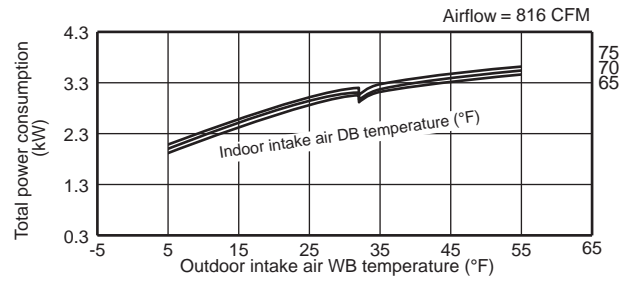
### MUZ-GS36NAH



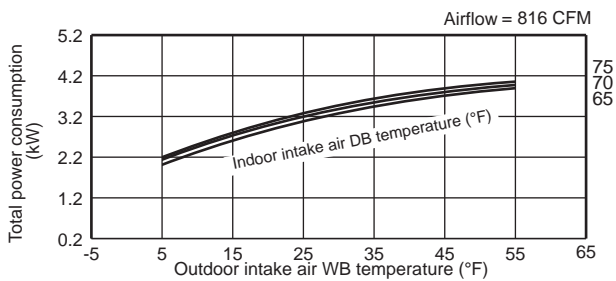
### MUZ-GS30NA2



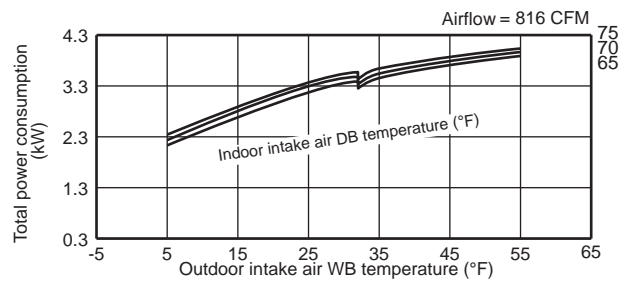
### MUZ-GS30NAH2



### MUZ-GS36NA2



### MUZ-GS36NAH2



This value of frequency is not the same as the actual frequency in operating. Refer to 7-5 and 7-6 for the relationships between frequency and capacity.

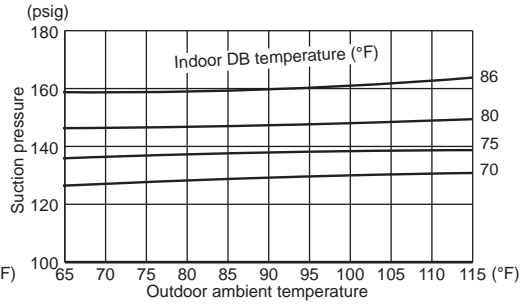
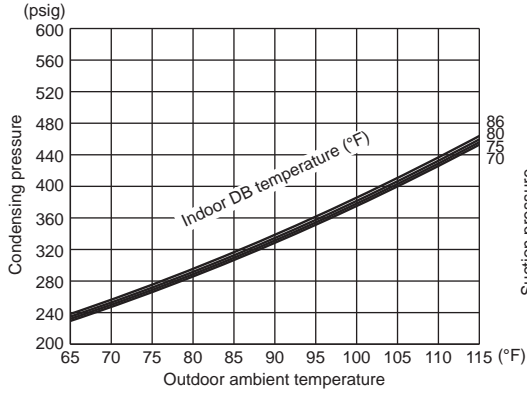
### 7-3. CONDENSING PRESSURE

#### Cooling

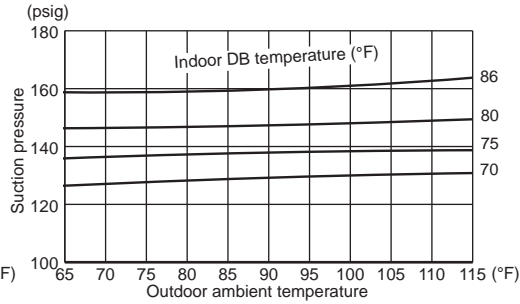
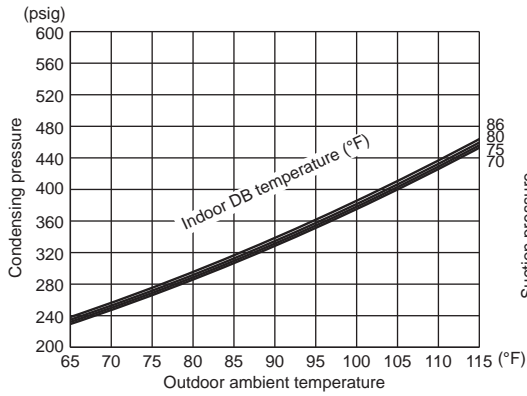
Data are based on the condition of indoor humidity 50 %.

Air flow should be set to High speed.

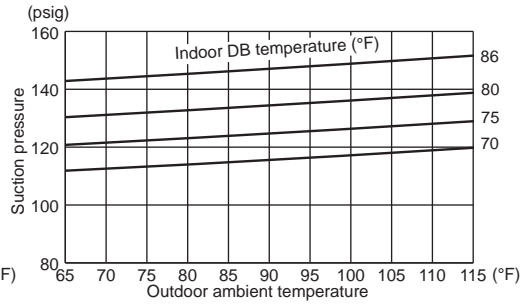
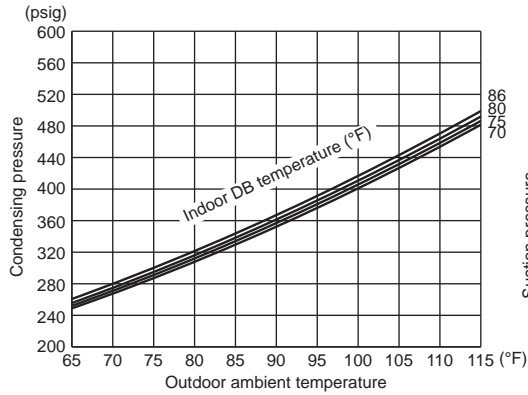
#### MUZ-GS09NA MUZ-GS09NAH MUY-GS09NA



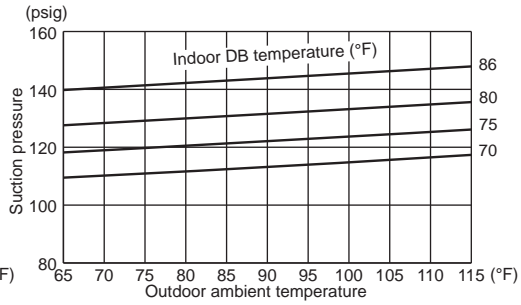
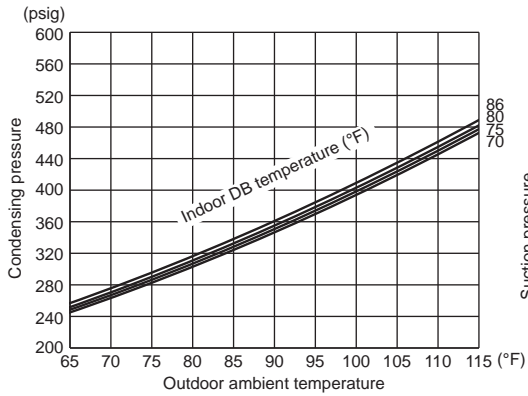
#### MUZ-GS09NAHZ



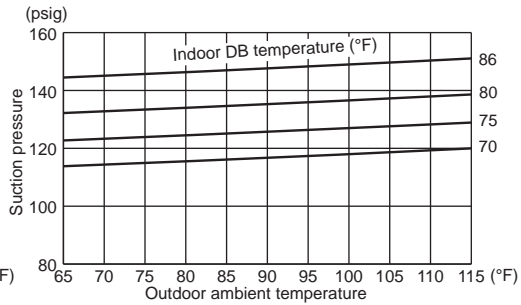
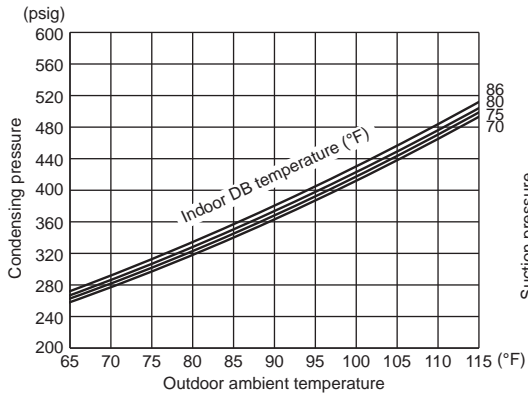
**MUZ-GS12NA MUZ-GS12NAH MUY-GS12NA**



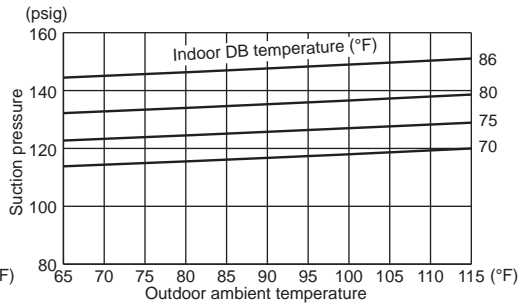
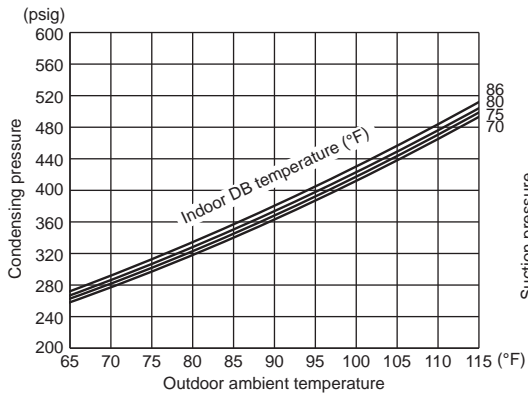
**MUZ-GS12NAHZ**



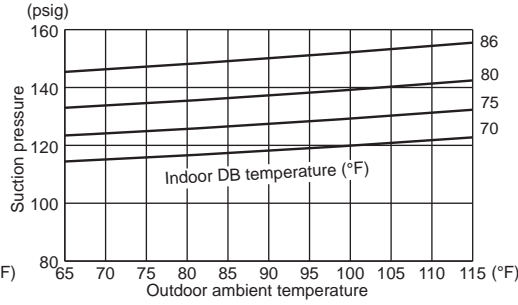
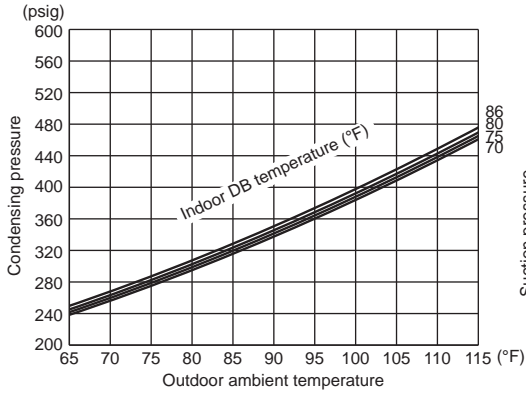
**MUZ-GS15NA MUZ-GS15NAH MUY-GS15NA**



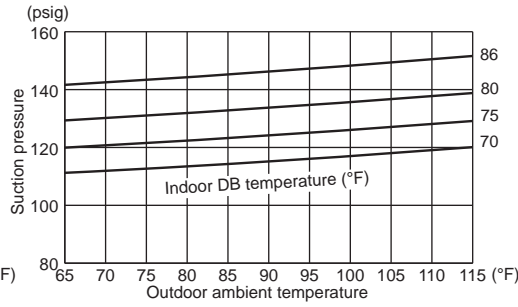
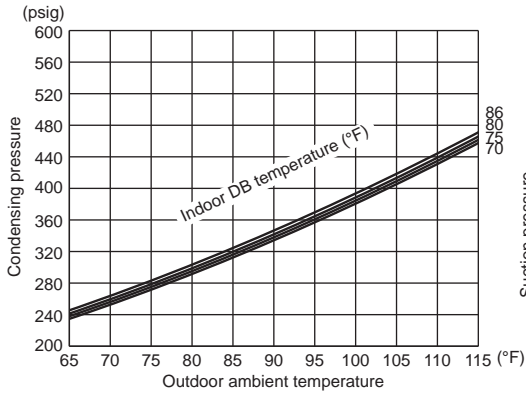
**MUZ-GS15NAHZ**



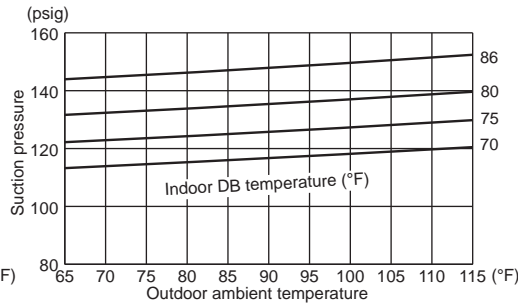
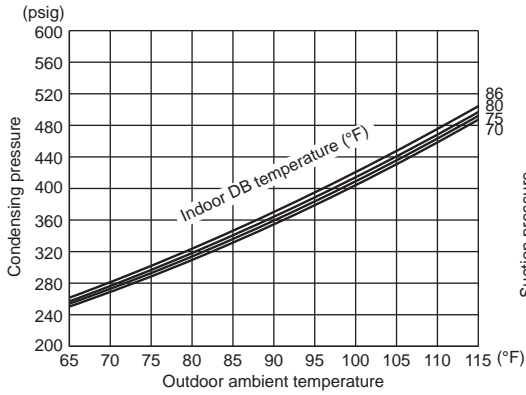
**MUZ-GS18NA MUZ-GS18NAH MUY-GS18NA**



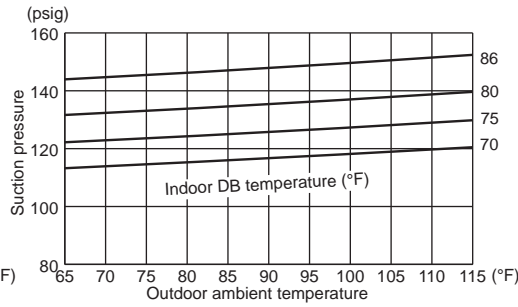
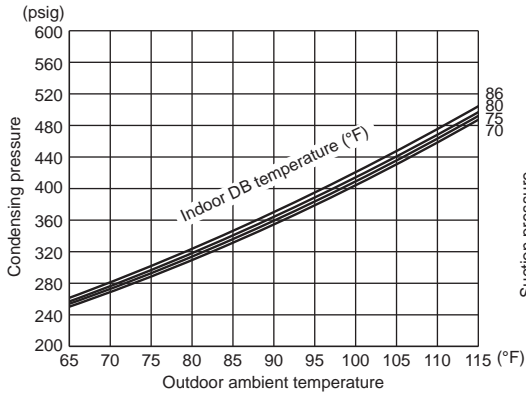
**MUZ-GS18NAHZ**



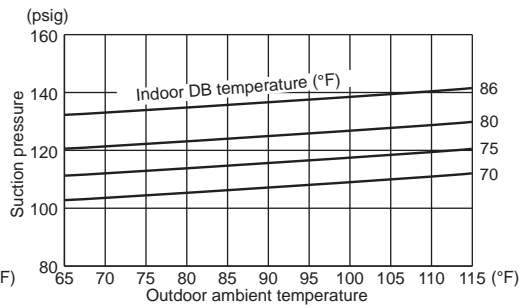
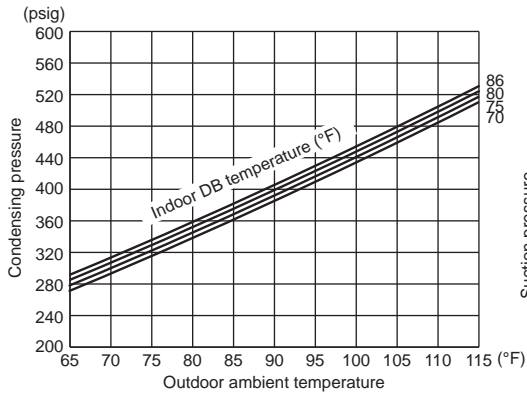
**MUZ-GS24NA MUZ-GS24NAH MUY-GS24NA**



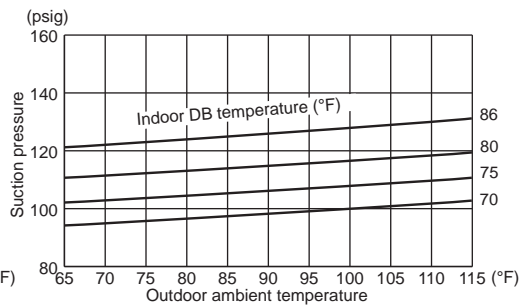
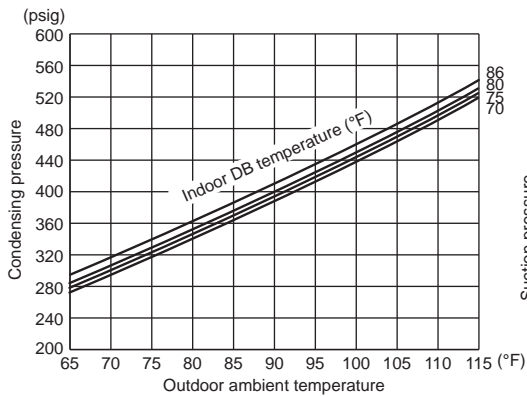
**MUZ-GS24NAHZ**



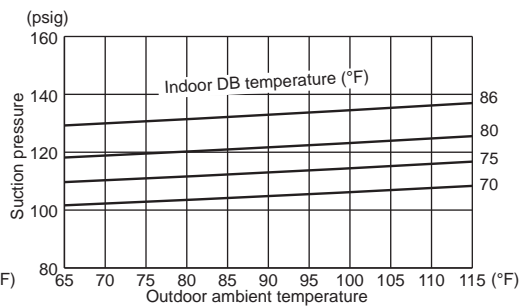
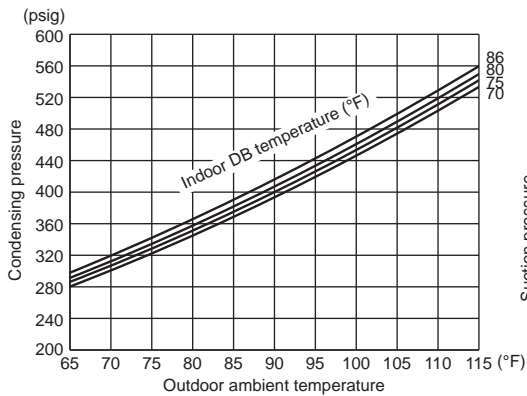
**MUZ-GS30NA MUZ-GS30NAH MUY-GS30NA**



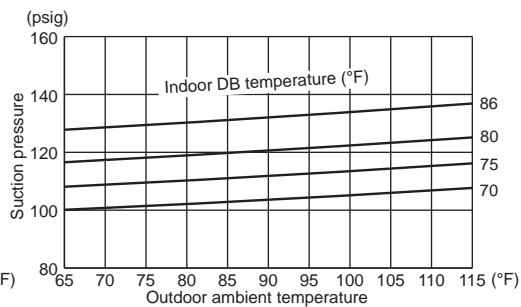
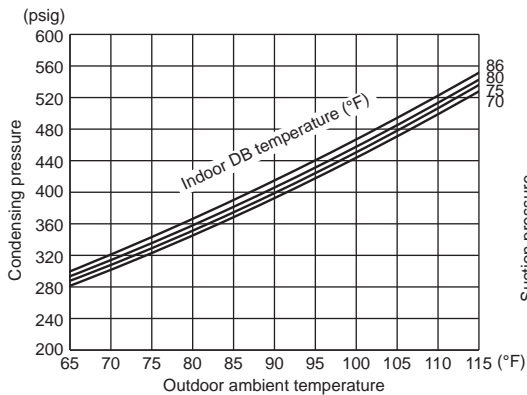
**MUZ-GS36NA MUZ-GS36NAH MUY-GS36NA**



**MUZ-GS30NA2 MUZ-GS30NAH2**

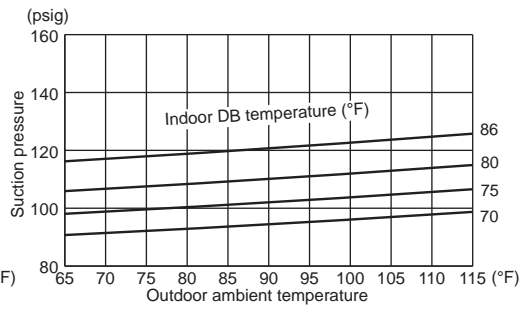
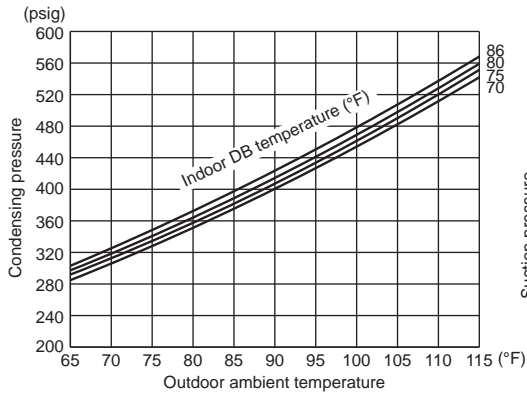


**MUY-GS30NA2**

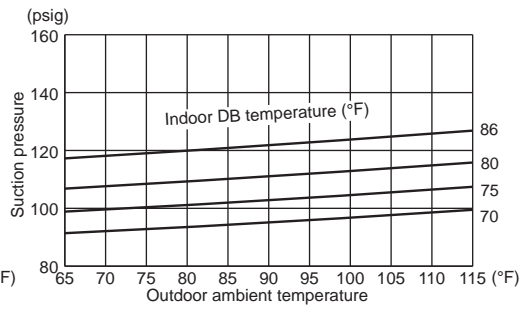
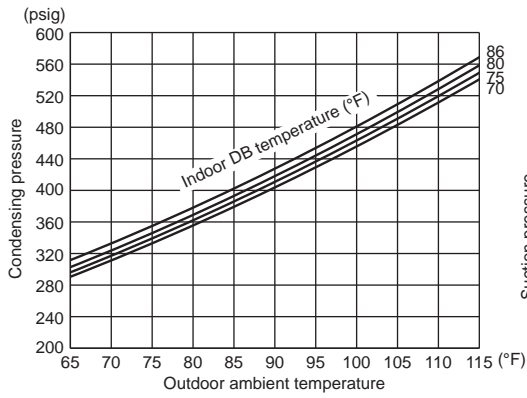




**MUZ-GS36NA2 MUZ-GS36NAH2**



**MUY-GS36NA2**



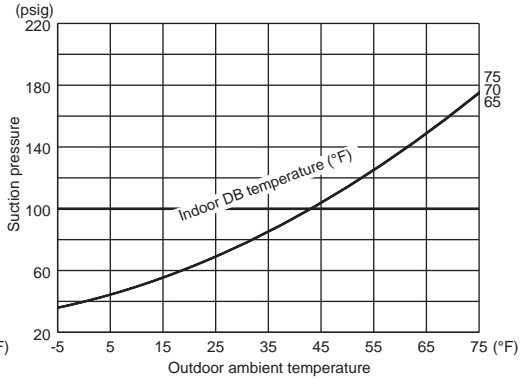
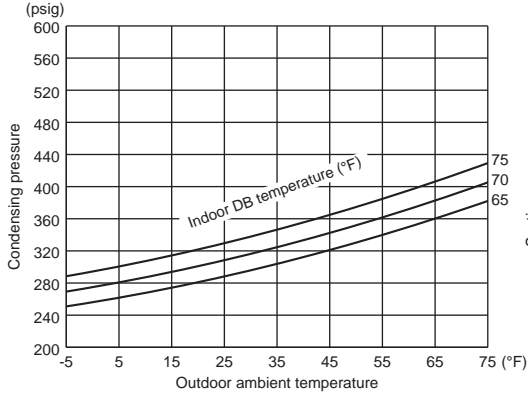
## Heating

Data are based on the condition of outdoor humidity 75%.

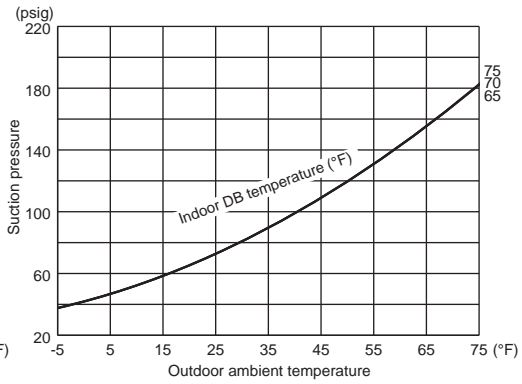
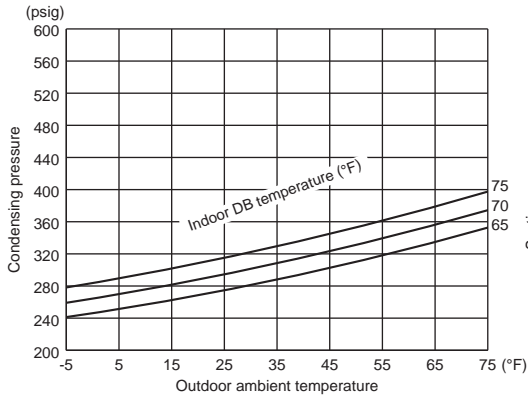
Air flow should be set to High speed.

Data are for heating operation without any frost.

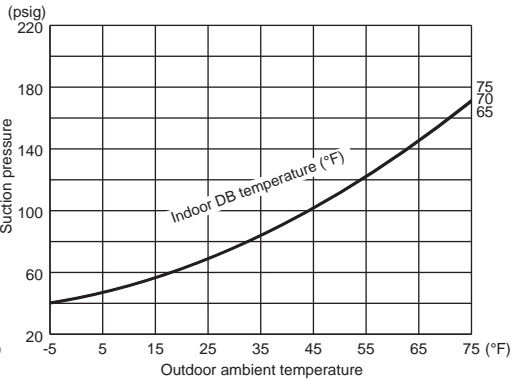
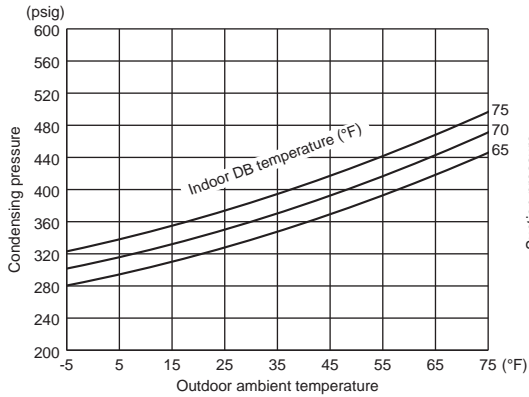
### MUZ-GS09NA MUZ-GS09NAH



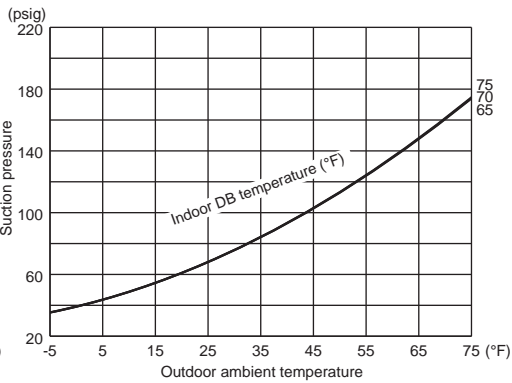
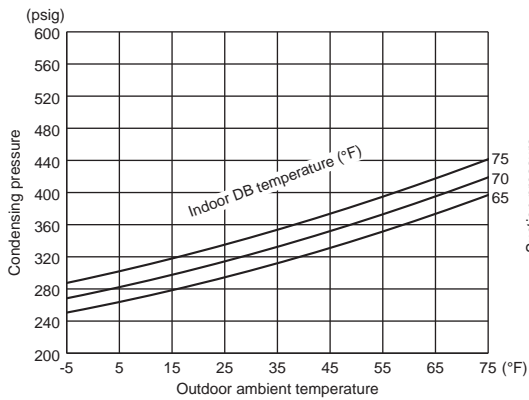
### MUZ-GS09NAHZ



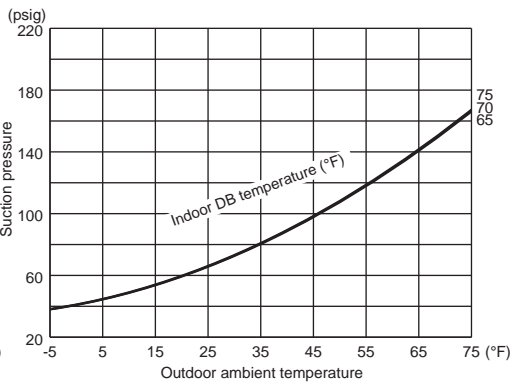
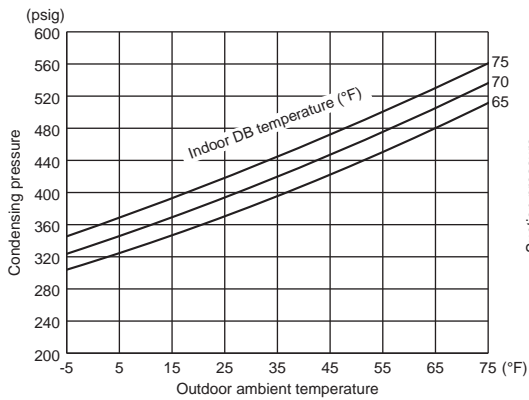
**MUZ-GS12NA MUZ-GS12NAH**



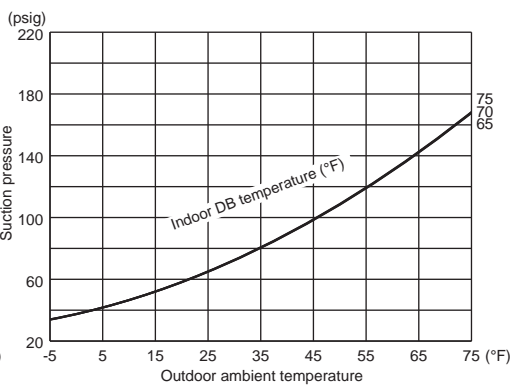
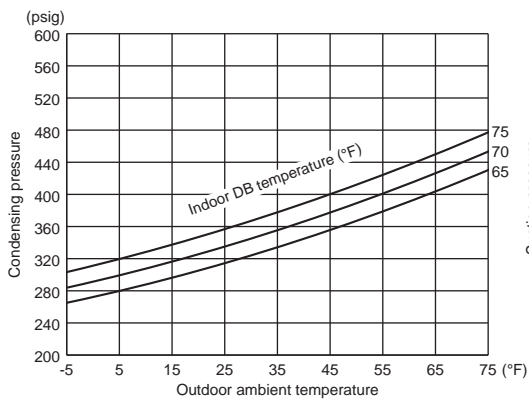
**MUZ-GS12NAHZ**



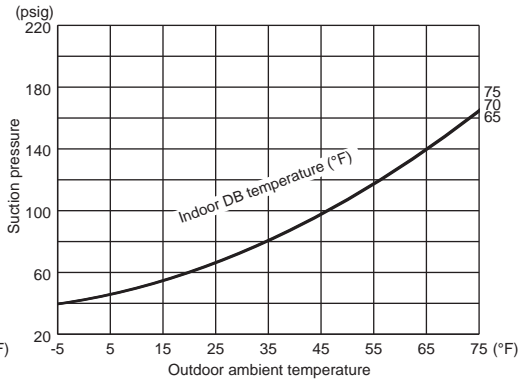
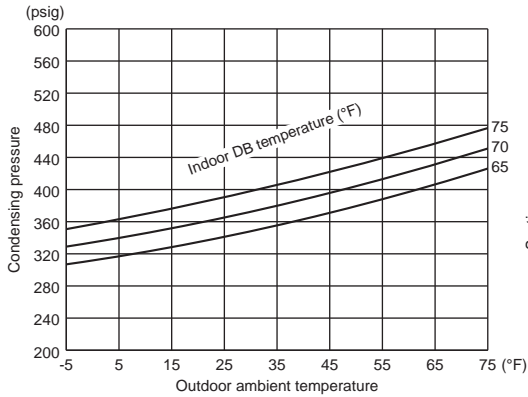
**MUZ-GS15NA MUZ-GS15NAH**



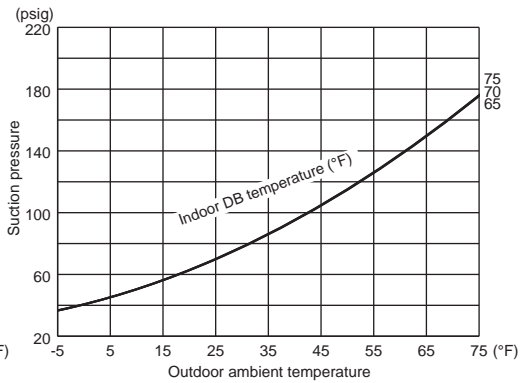
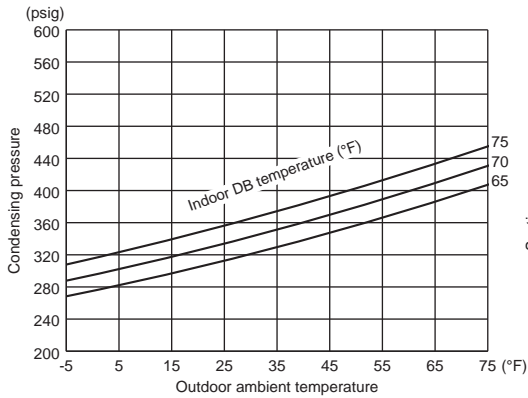
**MUZ-GS15NAHZ**



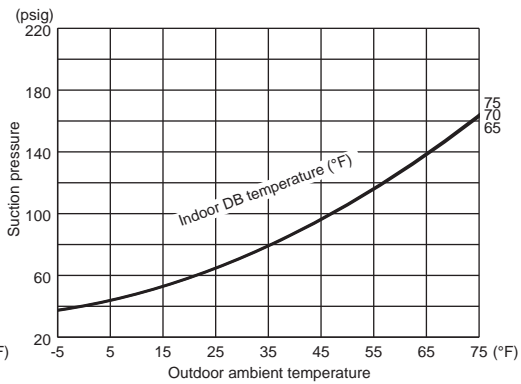
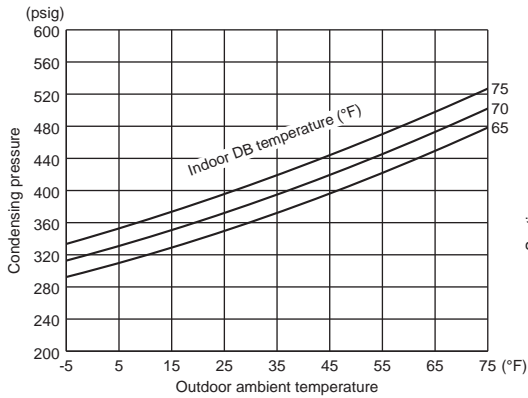
**MUZ-GS18NA MUZ-GS18NAH**



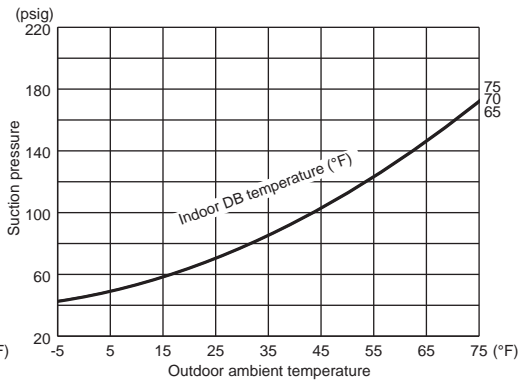
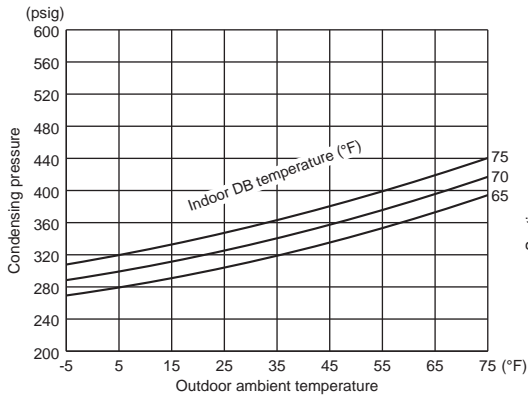
**MUZ-GS18NAHZ**



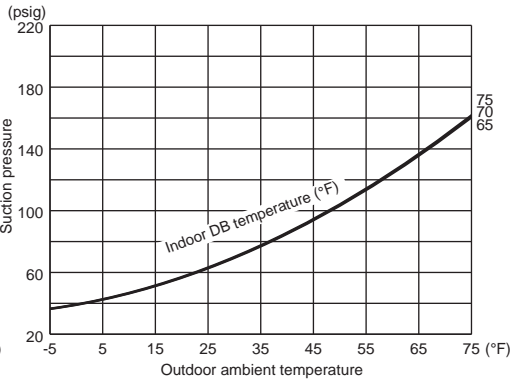
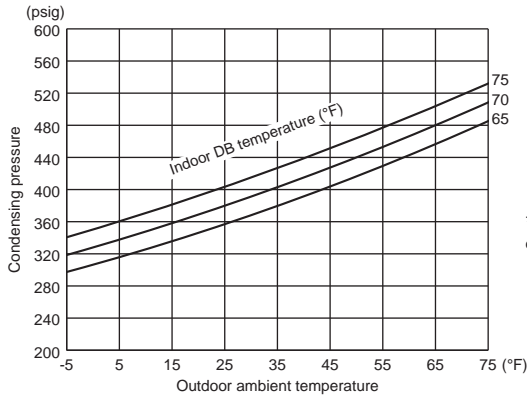
**MUZ-GS24NA MUZ-GS24NAH**



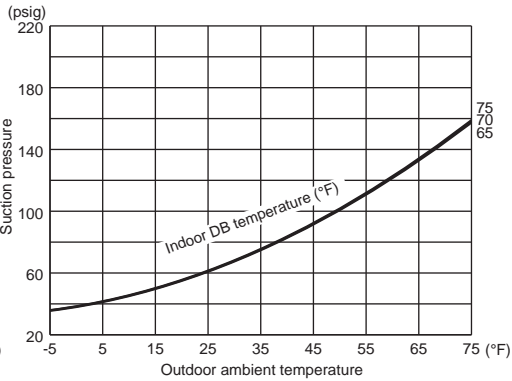
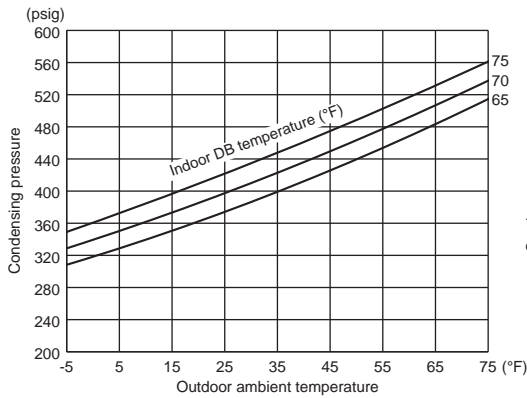
**MUZ-GS24NAHZ**



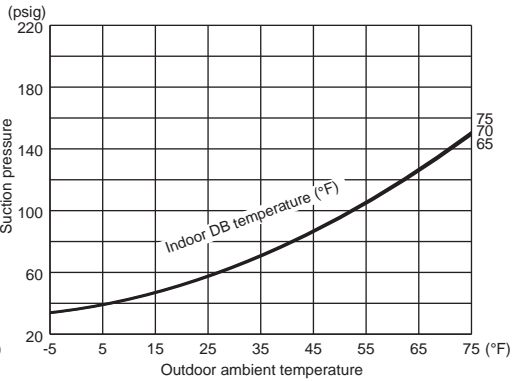
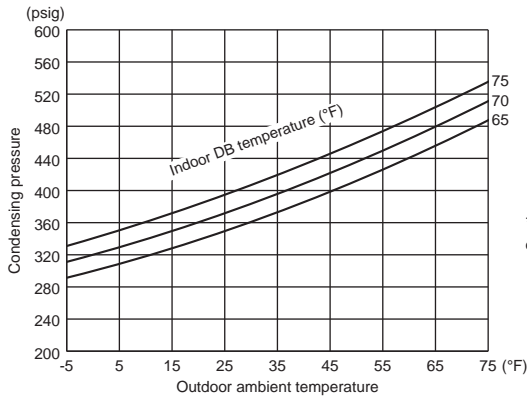
**MUZ-GS30NA MUZ-GS30NAH**



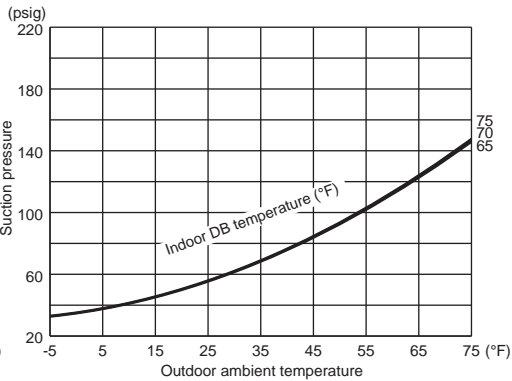
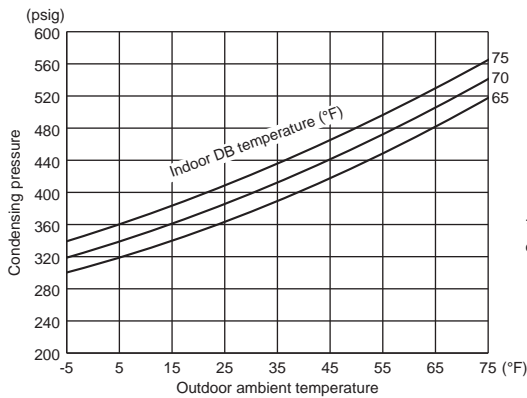
**MUZ-GS36NA MUZ-GS36NAH**



**MUZ-GS30NA2 MUZ-GS30NAH2**



**MUZ-GS36NA2 MUZ-GS36NAH2**



#### 7-4. STANDARD OPERATION DATA

Model			MSZ-GS09NA		MSZ-GS09NA		MSY-GS09NA	
Item		Unit	COOL	HEAT	COOL	HEAT	COOL	
Total	Capacity	Btu/h	9,000	10,900	9,000	9,600	9,000	
	SHF	—	0.9	—	0.9	—	0.9	
	Input	kW	0.585	0.72	0.585	0.58	0.585	
	Rated frequency	Hz	47	57.5	47	50	47	
Electrical circuit	Indoor unit		MSZ-GS09NA		MSZ-GS09NA		MSY-GS09NA	
	Power supply V, phase, Hz		208/230, 1, 60		208/230, 1, 60		208/230, 1, 60	
	Input	kW	0.021	0.023	0.021	0.023	0.021	
	Fan motor current	A	0.23/0.21	0.24/0.22	0.23/0.21	0.24/0.22	0.23/0.21	
	Outdoor unit		MUZ-GS09NA MUZ-GS09NAH		MUZ-GS09NAHZ		MUY-GS09NA	
	Power supply V, phase, Hz		208/230, 1, 60		208/230, 1, 60		208/230, 1, 60	
	Input	kW	0.564	0.697	0.564	0.557	0.564	
	Comp. current	A	2.29/2.07	2.90/2.63	2.29/2.07	2.37/2.15	2.29/2.07	
Fan motor current	A	0.45/0.41	0.41/0.37	0.45/0.41	0.41/0.37	0.45/0.41		
Refrigerant circuit	Condensing pressure	psig	359	347	359	324	359	
	Suction pressure	psig	153	109	153	112	153	
	Discharge temperature	°F	148	158	148	146	148	
	Condensing temperature	°F	109	106	109	101	109	
	Suction temperature	°F	64	46	64	45	64	
	Comp. shell bottom temperature	°F	138	144	138	133	138	
	Ref. pipe length	ft.	25		25		25	
	Refrigerant charge (R410A)		2lb. 9oz.		2lb. 9oz.		2lb. 9oz.	
Indoor unit	Intake air temperature	DB	°F	80	70	80	70	80
		WB	°F	67	60	67	60	67
	Discharge air temperature	DB	°F	60	98	60	94	60
		WB	°F	59	—	59	—	59
	Fan speed (High)	rpm	1,020	1,040	1,020	1,040	1,020	
Air flow (High)	CFM	343 (wet)	390	343 (wet)	390	343 (wet)		
Outdoor unit	Intake air temperature	DB	°F	95	47	95	47	95
		WB	°F	—	43	—	43	—
	Fan speed	rpm	900	860	900	860	900	
	Air flow	CFM	1,152	1,098	1,152	1,098	1,152	



Model			MSZ-GS12NA		MSZ-GS12NA		MSY-GS12NA	
Item		Unit	COOL	HEAT	COOL	HEAT	COOL	
Total	Capacity	Btu/h	12,000	14,400	12,000	12,300	12,000	
	SHF	—	0.77	—	0.77	—	0.77	
	Input	kW	0.92	1.1	0.92	0.83	0.92	
	Rated frequency	Hz	70	78	47.5	45.5	70	
Electrical circuit	Indoor unit		MSZ-GS12NA		MSZ-GS12NA		MSY-GS12NA	
	Power supply	V, phase, Hz	208/230, 1, 60		208/230, 1, 60		208/230, 1, 60	
	Input	kW	0.021	0.023	0.021	0.023	0.021	
	Fan motor current	A	0.23/0.21	0.24/0.22	0.23/0.21	0.24/0.22	0.23/0.21	
	Outdoor unit		MUZ-GS12NA MUZ-GS12NAH		MUZ-GS12NAHZ		MUY-GS12NA	
	Power supply	V, phase, Hz	208/230, 1, 60		208/230, 1, 60		208/230, 1, 60	
	Input	kW	0.899	1.077	0.899	0.807	0.899	
	Comp. current	A	3.88/3.51	4.60/4.16	3.85/3.48	3.67/3.32	3.88/3.51	
	Fan motor current	A	0.45/0.41	0.41/0.37	0.45/0.41	0.41/0.37	0.45/0.41	
	Refrigerant circuit	Condensing pressure	psig	386	395	379	372	386
Suction pressure		psig	136	105	135	107	136	
Discharge temperature		°F	161	165	162	161	161	
Condensing temperature		°F	114	116	113	111	114	
Suction temperature		°F	56	34	60	39	56	
Comp. shell bottom temperature		°F	150	153	151	147	150	
Ref. pipe length		ft.	25		25		25	
Refrigerant charge (R410A)			2lb. 9oz.		2lb. 9oz.		2lb. 9oz.	
Indoor unit	Intake air temperature	DB	°F	80	70	80	70	80
		WB	°F	67	60	67	60	67
	Discharge air temperature	DB	°F	56	108	56	103	56
		WB	°F	55	—	55	—	55
	Fan speed (High)	rpm	1,020	1,040	1,020	1,040	1,020	
Air flow (High)	CFM	343 (wet)	390	343 (wet)	390	343 (wet)		
Outdoor unit	Intake air temperature	DB	°F	95	47	95	47	95
		WB	°F	—	43	—	43	—
	Fan speed	rpm	900	860	900	860	900	
	Air flow	CFM	1,152	1,098	1,152	1,098	1,152	



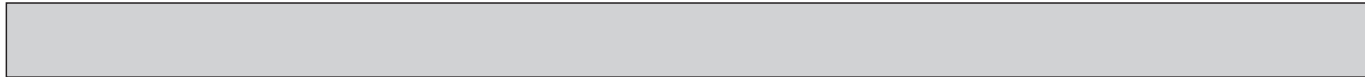


Model			MSZ-GS15NA		MSZ-GS15NA		MSY-GS15NA	
Item		Unit	COOL	HEAT	COOL	HEAT	COOL	
Total	Capacity	Btu/h	14,000	18,000	14,000	14,000	14,000	
	SHF	—	0.8	—	0.8	—	0.8	
	Input	kW	1.1	1.6	1.1	1.14	1.1	
	Rated frequency	Hz	55	71	55	57.5	55	
Electrical circuit	Indoor unit		MSZ-GS15NA		MSZ-GS15NA		MSY-GS15NA	
	Power supply	V, phase, Hz	208/230, 1, 60		208/230, 1, 60		208/230, 1, 60	
	Input	kW	0.045	0.030	0.045	0.030	0.045	
	Fan motor current	A	0.43/0.39	0.32/0.29	0.43/0.39	0.32/0.29	0.43/0.39	
	Outdoor unit		MUZ-GS15NA MUZ-GS15NAH		MUZ-GS15NAHZ		MUY-GS15NA	
	Power supply	V, phase, Hz	208/230, 1, 60		208/230, 1, 60		208/230, 1, 60	
	Input	kW	1.055	1.570	1.055	1.110	1.055	
	Comp. current	A	4.71/4.26	7.04/6.36	4.71/4.26	4.29/3.88	4.71/4.26	
	Fan motor current	A	0.46/0.42	0.45/0.41	0.46/0.42	0.45/0.41	0.46/0.42	
Refrigerant circuit	Condensing pressure	psig	398	449	398	381	398	
	Suction pressure	psig	139	101	139	103	139	
	Discharge temperature	°F	167	183	167	170	167	
	Condensing temperature	°F	116	125	116	113	116	
	Suction temperature	°F	61	32	61	44	61	
	Comp. shell bottom temperature	°F	153	169	153	150	153	
	Ref. pipe length	ft.	25		25		25	
	Refrigerant charge (R410A)		2lb. 9oz.		2lb. 9oz.		2lb. 9oz.	
Indoor unit	Intake air temperature	DB	°F	80	70	80	70	80
		WB	°F	67	60	67	60	67
	Discharge air temperature	DB	°F	59	118	59	103	59
		WB	°F	58	—	58	—	58
	Fan speed (High)	rpm	1,280	1,140	1,280	1,140	1,280	
Airflow (High)	CFM	454 (wet)	437	454 (wet)	437	454 (wet)		
Outdoor unit	Intake air temperature	DB	°F	95	47	95	47	95
		WB	°F	—	43	—	43	—
	Fan speed	rpm	910	900	910	900	910	
	Airflow	CFM	1,166	1,152	1,166	1,152	1,166	

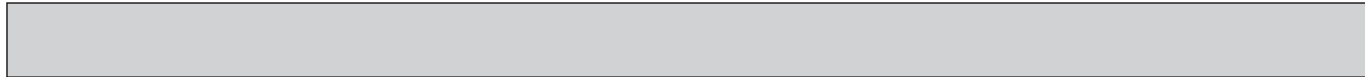
Model			MSZ-GS18NA		MSZ-GS18NA		MSY-GS18NA	
Item		Unit	COOL	HEAT	COOL	HEAT	COOL	
Total	Capacity	Btu/h	18,000	19,000	18,000	19,000	18,000	
	SHF	—	0.77	—	0.77	—	0.77	
	Input	kW	1.34	1.34	1.34	1.34	1.34	
	Rated frequency	Hz	71	83	54	55	71	
Electrical circuit	Indoor unit		MSZ-GS18NA		MSZ-GS18NA		MSY-GS18NA	
	Power supply	V, phase, Hz	208/230, 1, 60		208/230, 1, 60		208/230, 1, 60	
	Input	kW	0.042	0.042	0.042	0.042	0.042	
	Fan motor current	A	0.42/0.38	0.42/0.38	0.42/0.38	0.42/0.38	0.42/0.38	
	Outdoor unit		MUZ-GS18NA MUZ-GS18NAH		MUZ-GS18NAHZ		MUY-GS18NA	
	Power supply	V, phase, Hz	208/230, 1, 60		208/230, 1, 60		208/230, 1, 60	
	Input	kW	1.298	1.298	1.298	1.298	1.298	
	Comp. current	A	5.56/5.03	7.40/6.69	4.94/4.47	5.29/4.78	5.56/5.03	
	Fan motor current	A	0.45/0.41	0.35/0.32	0.86/0.77	0.74/0.67	0.45/0.41	
	Refrigerant circuit	Condensing pressure	psig	369	400	365	372	369
Suction pressure		psig	138	101	139	110	138	
Discharge temperature		°F	151	168	153	163	151	
Condensing temperature		°F	111	117	110	111	111	
Suction temperature		°F	53	33	56	43	53	
Comp. shell bottom temperature		°F	133	150	138	143	133	
Ref. pipe length		ft.	25		25		25	
Refrigerant charge (R410A)			3lb. 7oz.		3lb. 7oz.		3lb. 7oz.	
Indoor unit	Intake air temperature	DB	°F	80	70	80	70	80
		WB	°F	67	60	67	60	67
	Discharge air temperature	DB	°F	57	107	58	103	57
		WB	°F	56	—	57	—	56
	Fan speed (High)	rpm	1,170	1,170	1,170	1,170	1,170	
Airflow (High)	CFM	566 (wet)	629	566 (wet)	629	566 (wet)		
Outdoor unit	Intake air temperature	DB	°F	95	47	95	47	95
		WB	°F	—	43	—	43	—
	Fan speed	rpm	740	680	740	680	740	
	Airflow	CFM	1,947	1,732	1,800	1,646	1,947	



Model			MSZ-GS24NA		MSZ-GS24NA		MSY-GS24NA	
Item		Unit	COOL	HEAT	COOL	HEAT	COOL	
Total	Capacity	Btu/h	22,500	27,600	22,500	20,800	22,500	
	SHF	—	0.75	—	0.75	—	0.75	
	Input	kW	1.8	2.34	1.8	1.52	1.8	
	Rated frequency	Hz	67	81.5	67	62	67	
Electrical circuit	Indoor unit		MSZ-GS24NA		MSZ-GS24NA		MSY-GS24NA	
	Power supply	V, phase, Hz	208/230, 1, 60		208/230, 1, 60		208/230, 1, 60	
	Input	kW	0.055	0.055	0.055	0.055	0.055	
	Fan motor current	A	0.51/0.46	0.51/0.46	0.51/0.46	0.51/0.46	0.51/0.46	
	Outdoor unit		MUZ-GS24NA MUZ-GS24NAH		MUZ-GS24NAHZ		MUY-GS24NA	
	Power supply	V, phase, Hz	208/230, 1, 60		208/230, 1, 60		208/230, 1, 60	
	Input	kW	1.745	2.285	1.745	1.465	1.745	
	Comp. current	A	6.92/6.26	9.70/8.77	6.92/6.26	5.83/5.27	6.92/6.26	
Refrigerant circuit	Fan motor current	A	1.00/0.91	0.95/0.86	1.00/0.91	0.95/0.86	1.00/0.91	
	Condensing pressure	psig	389	422	389	359	389	
	Suction pressure	psig	134	99	134	106	134	
	Discharge temperature	°F	159	170	159	147	159	
	Condensing temperature	°F	115	121	115	109	115	
	Suction temperature	°F	51	32	51	35	51	
	Comp. shell bottom temperature	°F	150	158	150	135	150	
	Ref. pipe length	ft.	25		25		25	
Refrigerant charge (R410A)		4lb. 5oz		4lb. 5oz		4lb. 5oz		
Indoor unit	Intake air temperature	DB	°F	80	70	80	70	80
		WB	°F	67	60	67	60	67
	Discharge air temperature	DB	°F	56	112	56	101	56
		WB	°F	55	—	55	—	55
	Fan speed (High)	rpm	1,300	1,300	1,300	1,300	1,300	
Airflow (High)	CFM	631 (wet)	701	631 (wet)	701	631 (wet)		
Outdoor unit	Intake air temperature	DB	°F	95	47	95	47	95
		WB	°F	—	43	—	43	—
	Fan speed	rpm	800	800	800	800	800	
	Airflow	CFM	1,950	1,900	1,950	1,900	1,950	



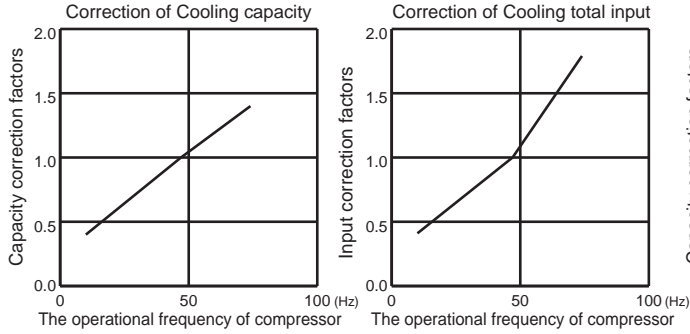
Model			MSZ-GS30NA		MSY-GS30NA	MSZ-GS36NA		MSY-GS36NA	
Item		Unit	Cooling	Heating	Cooling	Cooling	Heating	Cooling	
Total	Capacity	Btu/h	30,700	32,600	30,700	32,000/33,200	35,200	32,000/33,200	
	SHF	—	0.72	—	0.72	0.69	—	0.69	
	Input	kW	3.32	3.34	3.32	3.63/3.77	3.74	3.63/3.77	
	Rated frequency	Hz	78	82	78	92	89	92	
Electrical circuit	Indoor unit		MSZ-GS30NA		MSY-GS30NA	MSZ-GS36NA		MSY-GS36NA	
	Power supply		V, phase, Hz		208/230, 1, 60				
	Input	kW	0.078	0.055	0.078	0.078	0.055	0.078	
	Fan motor current	A	0.70/0.63	0.52/0.47	0.70/0.63	0.70/0.63	0.52/0.47	0.70/0.63	
	Outdoor unit		MUZ-GS30NA MUZ-GS30NAH		MUY-GS30NA	MUZ-GS36NA MUZ-GS36NAH		MUY-GS36NA	
	Power supply		V, phase, Hz		208/230, 1, 60				
	Input	kW	3.242	3.285	3.242	3.552/3.692	3.685	3.552/3.692	
	Comp. current	A	12.61/11.41	13.25/11.98	12.61/11.41	14.42/15.18	15.68/14.18	14.42/15.18	
	Fan motor current	A	0.84/0.76	0.83/0.75	0.84/0.76	0.98/0.89	0.83/0.75	0.98/0.89	
	Refrigerant circuit	Condensing pressure	psig	423	430	423	426	452	426
Suction pressure		psig	125	97	125	114	95	114	
Discharge temperature		°F	175	180	175	182	185	182	
Condensing temperature		°F	121	122	121	121	126	121	
Suction temperature		°F	49	30	49	44	29	44	
Comp. shell bottom temperature		°F	164	169	164	170	172	170	
Ref. pipe length		ft.	25						
Refrigerant charge (R410A)			4 lb.						
Indoor unit	Intake air temperature	DB	°F	80	70	80	80	70	80
		WB	°F	67	60	67	67	60	67
	Discharge air temperature	DB	°F	54	116	54	53	119	53
		WB	°F	53	—	53	52	—	52
	Fan speed (High)	rpm	1,230	1,100	1,230	1,230	1,100	1,230	
Airflow (High)	CFM	823 (Wet)	803	823 (Wet)	823 (Wet)	803	823 (Wet)		
Outdoor unit	Intake air temperature	DB	°F	95	47	95	95	47	95
		WB	°F	—	43	—	—	43	—
	Fan speed	rpm	810	800	810	900	800	900	
	Airflow	CFM	1,974	1,950	1,974	2,191	1,950	2,191	



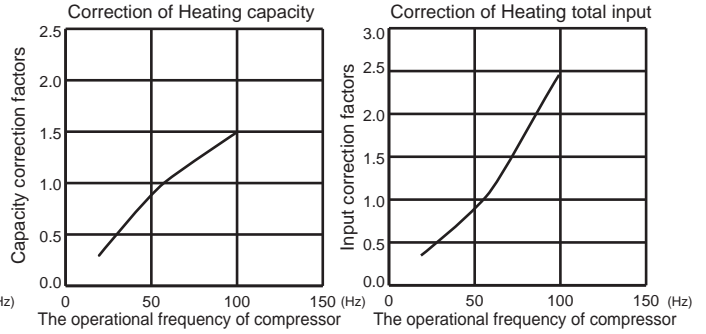
Model			MSZ-GS30NA2		MSY-GS30NA2	MSZ-GS36NA2		MSY-GS36NA2	
Item		Unit	COOL	HEAT	COOL	COOL	HEAT	COOL	
Total	Capacity	Btu/h	30,600	32,600	30,600	33,200	35,200	33,200	
	SHF	—	0.72	—	0.72	0.69	—	0.69	
	Input	kW	3.32	3.34	3.32	3.77	3.74	3.77	
	Rated frequency	Hz	78	82	78	92	91	92	
Electrical circuit	Indoor unit		MSZ-GS30NA2		MSY-GS30NA2	MSZ-GS36NA2		MSY-GS36NA2	
	Power supply	V, phase, Hz	208/230, 1, 60		208/230, 1, 60	208/230, 1, 60		208/230, 1, 60	
	Input	kW	0.084	0.058	0.084	0.084	0.058	0.084	
	Fan motor current	A	0.74/0.67	0.54/0.49	0.74/0.67	0.74/0.67	0.54/0.49	0.74/0.67	
	Outdoor unit		MUZ-GS30NA2 MUZ-GS30NAH2		MUY-GS30NA2	MUZ-GS36NA2 MUZ-GS36NAH2		MUY-GS36NA2	
	Power supply	V, phase, Hz	208/230, 1, 60		208/230, 1, 60	208/230, 1, 60		208/230, 1, 60	
	Input	kW	3.236	3.282	3.236	3.686	3.682	3.686	
	Comp. current	A	12.22/11.05	12.41/11.22	12.51/11.31	15.29/13.83	15.11/13.67	16.14/14.60	
	Fan motor current	A	1.03/0.93	1.01/0.91	0.92/0.84	1.33/1.21	1.01/0.91	0.99/0.89	
	Refrigerant circuit	Condensing pressure	psig	434	426	432	437	446	446
Suction pressure		psig	122	89	121	112	87	111	
Discharge temperature		°F	179	184	173	184	181	178	
Condensing temperature		°F	123	121	122	123	125	125	
Suction temperature		°F	49	30	48	44	27	42	
Comp. shell bottom temperature		°F	152	151	156	169	149	159	
Ref. pipe length		ft.	25		25	25		25	
Refrigerant charge (R410A)		4lb. 5oz.		4lb. 5oz.	4lb. 5oz.		4lb. 5oz.		
Indoor unit		Intake air temperature	DB	°F	80	70	80	80	70
	WB		°F	67	60	67	67	60	67
	Discharge air temperature	DB	°F	56	112	56	55	116	55
		WB	°F	55	—	55	54	—	54
	Fan speed (High)	rpm	1,230	1,100	1,230	1,230	1,100	1,230	
	Airflow (High)	CFM	839 (wet)	816	839 (wet)	839 (wet)	816	839 (wet)	
Outdoor unit	Intake air temperature	DB	°F	95	47	95	95	47	95
		WB	°F	—	43	—	—	43	—
	Fan speed	rpm	810	800	810	900	800	840	
	Airflow	CFM	1,974	1,950	1,990	2,191	1,950	2,070	

## 7-5. CAPACITY AND INPUT CORRECTION BY INVERTER OUTPUT FREQUENCY

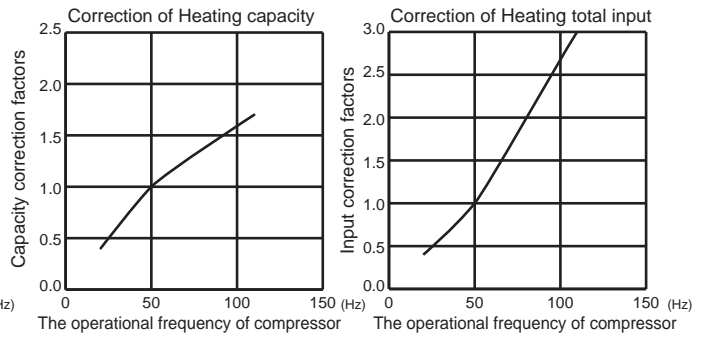
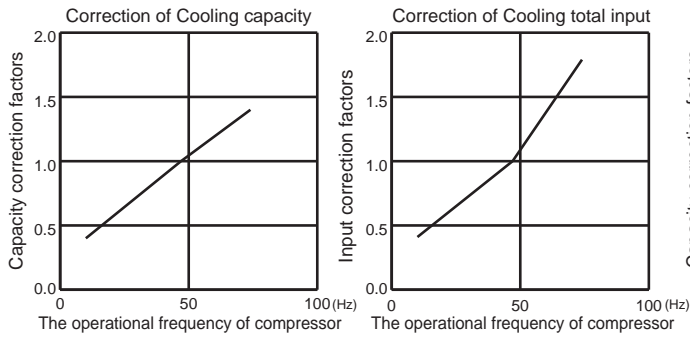
### MUZ-GS09NA MUZ-GS09NAH MUY-GS09NA



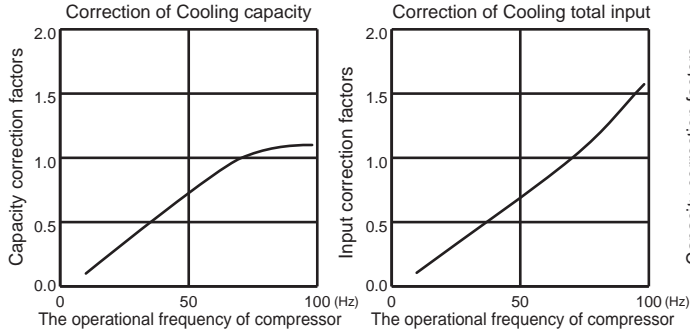
### MUZ-GS09NA MUZ-GS09NAH



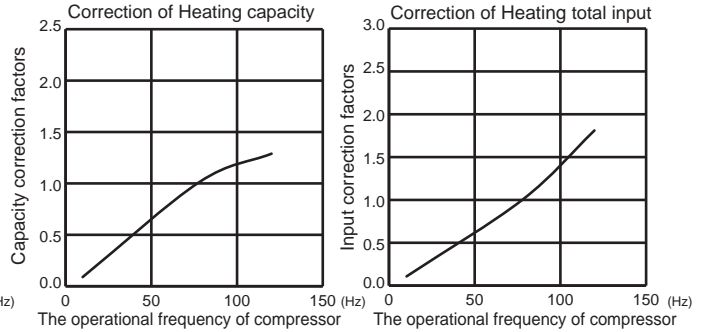
### MUZ-GS09NAHZ



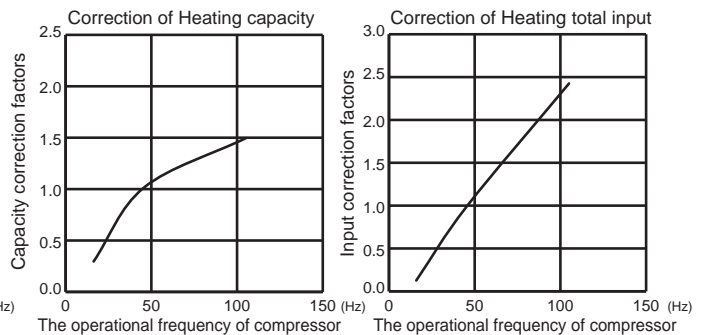
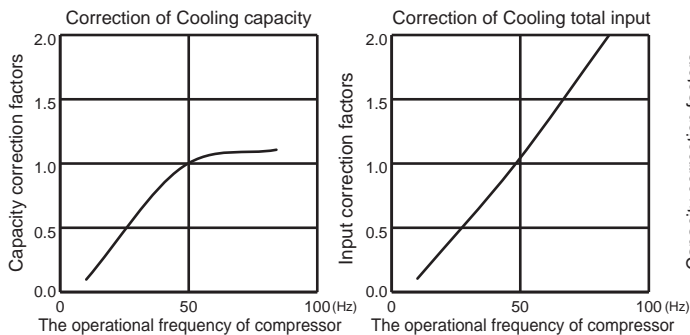
### MUZ-GS12NA MUZ-GS12NAH MUY-GS12NA



### MUZ-GS12NA MUZ-GS12NAH



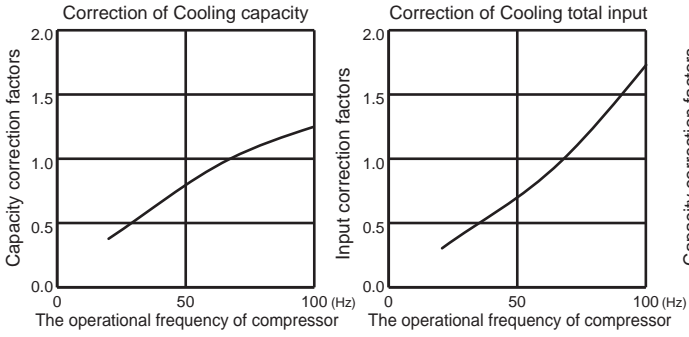
### MUZ-GS12NAHZ



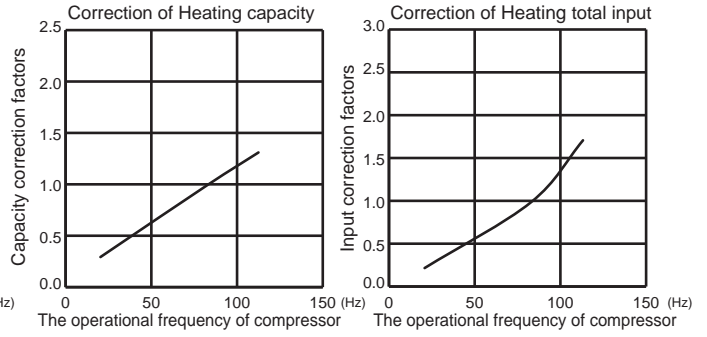




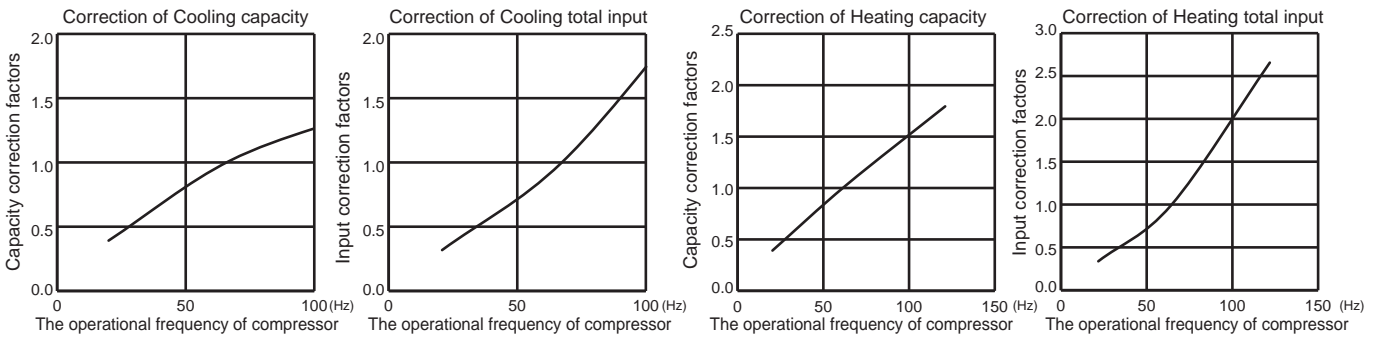
**MUZ-GS24NA MUZ-GS24NAH MUY-GS24NA**



**MUZ-GS24NA MUZ-GS24NAH**

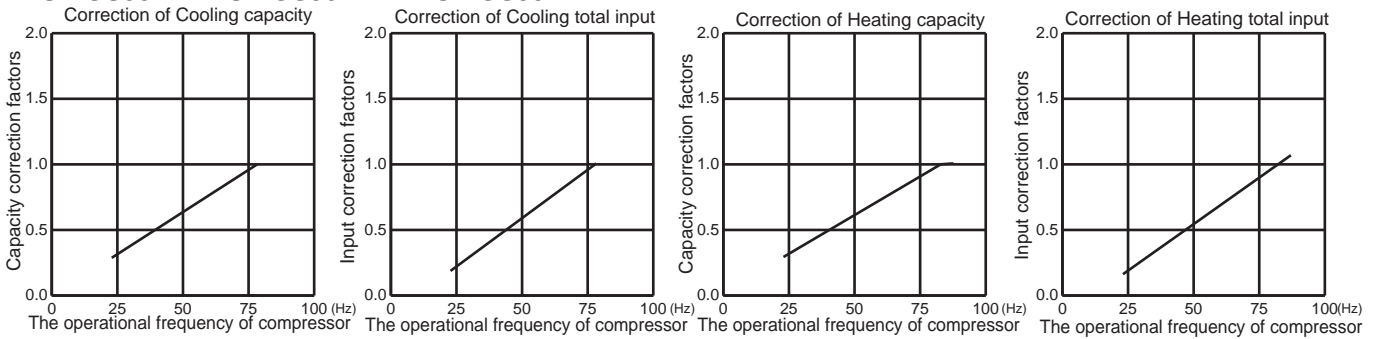


**MUZ-GS24NAHZ**

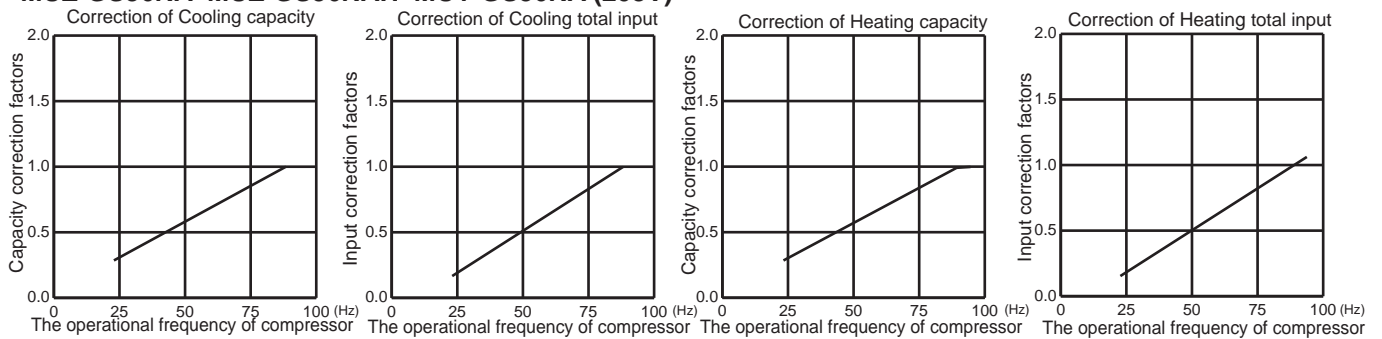




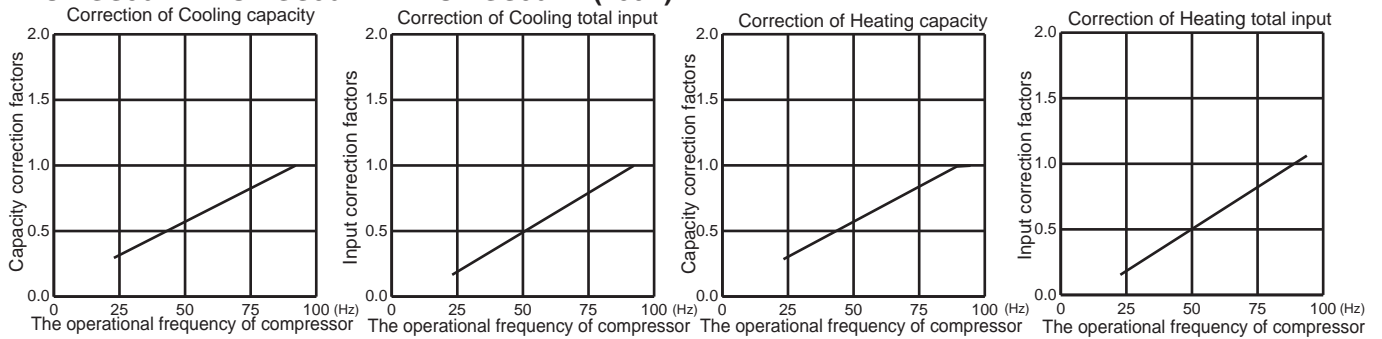
**MUZ-GS30NA MUZ-GS30NAH MUY-GS30NA**



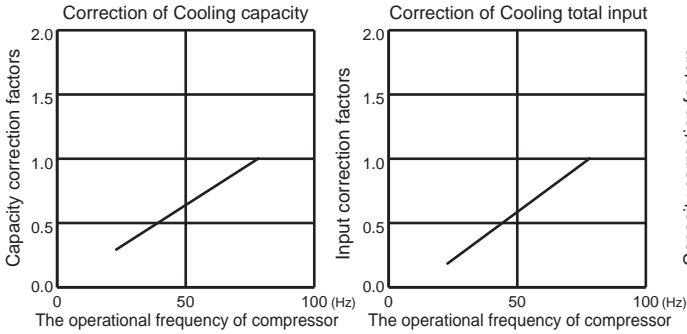
**MUZ-GS36NA MUZ-GS36NAH MUY-GS36NA (208V)**



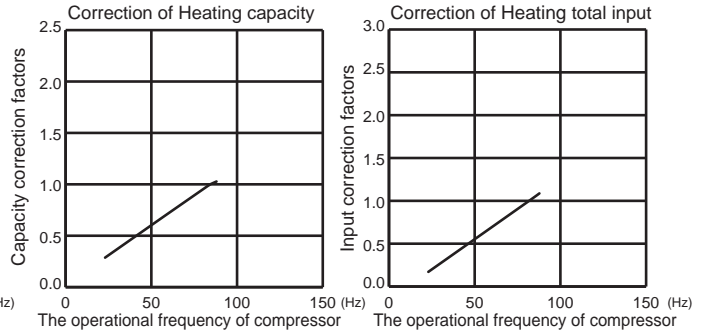
**MUZ-GS36NA MUZ-GS36NAH MUY-GS36NA (230V)**



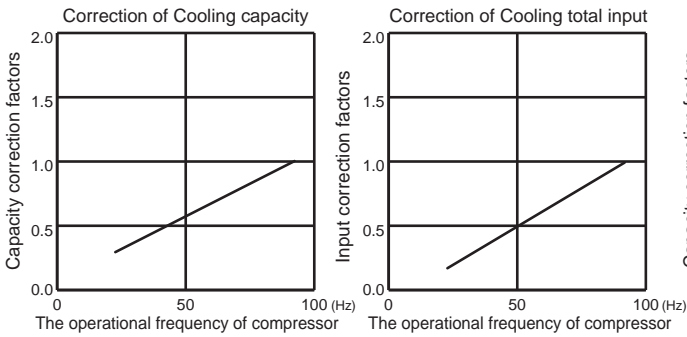
**MUZ-GS30NA2 MUZ-GS30NAH2 MUY-GS30NA2**



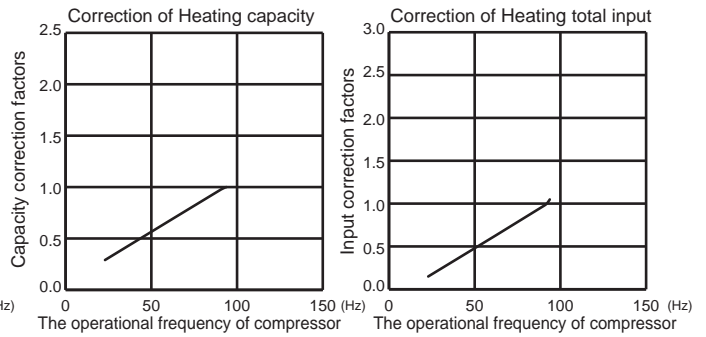
**MUZ-GS30NA2 MUZ-GS30NAH2**



**MUZ-GS36NA2 MUZ-GS36NAH2 MUY-GS36NA2**



**MUZ-GS36NA2 MUZ-GS36NAH2**



**7-6. HOW TO OPERATE FIXED-FREQUENCY OPERATION (Test run operation)**

1. Press the emergency operation switch to start COOL or HEAT mode (COOL: Press once, HEAT: Press twice).
2. Test run operation starts and continues to operate for 30 minutes.
3. Compressor operates at rated frequency in COOL mode or 58 Hz in HEAT mode.
4. Indoor fan operates at High speed.
5. After 30 minutes, test run operation finishes and EMERGENCY OPERATION starts (operation frequency of compressor varies).
6. To cancel test run operation (EMERGENCY OPERATION), press the emergency operation switch or any button on remote controller.

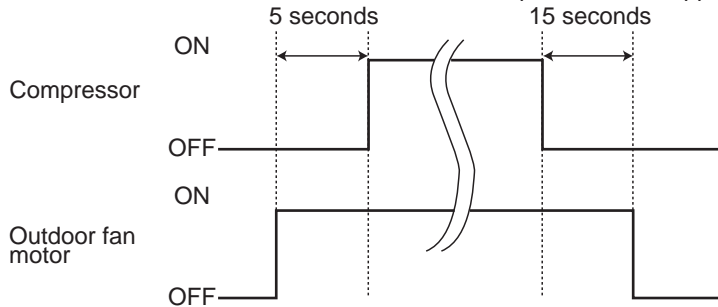
MUZ-GS09NA MUZ-GS09NAH MUZ-GS09NAHZ MUY-GS09NA  
 MUZ-GS12NA MUZ-GS12NAH MUZ-GS12NAHZ MUY-GS12NA  
 MUZ-GS15NA MUZ-GS15NAH MUZ-GS15NAHZ MUY-GS15NA  
 MUZ-GS18NA MUZ-GS18NAH MUZ-GS18NAHZ MUY-GS18NA  
 MUZ-GS24NA MUZ-GS24NAH MUZ-GS24NAHZ MUY-GS24NA  
 MUZ-GS30NA MUZ-GS30NAH MUY-GS30NA MUZ-GS30NA2 MUZ-GS30NAH2 MUY-GS30NA2  
 MUZ-GS36NA MUZ-GS36NAH MUY-GS36NA MUZ-GS36NA2 MUZ-GS36NAH2 MUY-GS36NA2

**8-1. OUTDOOR FAN MOTOR CONTROL**

The fan motor turns ON/OFF, interlocking with the compressor.

[ON] The fan motor turns ON 5 seconds before the compressor starts up.

[OFF] The fan motor turns OFF 15 seconds after the compressor has stopped running.



**8-2. R.V. COIL CONTROL**

Heating . . . . . ON

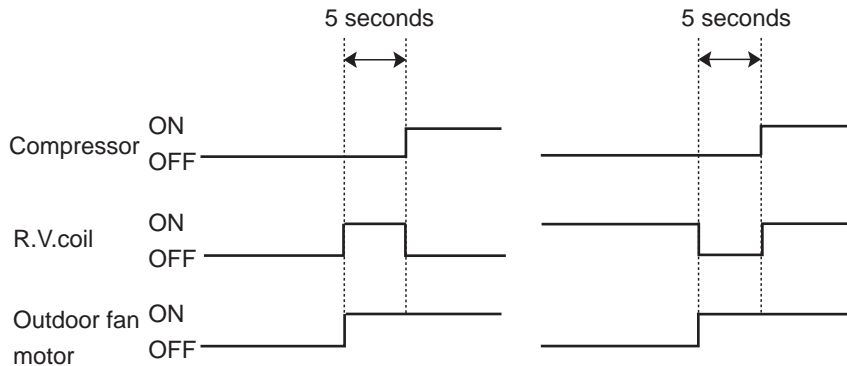
Cooling . . . . . OFF

Dry . . . . . OFF

**NOTE:** The 4-way valve reverses for 5 seconds right before startup of the compressor.

<COOL>

<HEAT>



**8-3. RELATION BETWEEN MAIN SENSOR AND ACTUATOR**

Sensor	Purpose	Actuator					
		Compressor	LEV	Outdoor fan motor	R.V.coil	Indoor fan motor	Defrost heater *
Discharge temperature thermistor	Protection	○	○				
Indoor coil temperature thermistor	Cooling: Coil frost prevention	○					
	Heating: High pressure protection	○	○				
Defrost thermistor	Heating: Defrosting	○	○	○	○	○	
Fin temperature thermistor	Protection	○		○			
Ambient temperature thermistor	Cooling: Low ambient temperature operation	○	○	○			
	Heating: Defrosting (Heater)						○
Outdoor heat exchanger temperature thermistor	Cooling: Low ambient temperature operation	○	○	○			
	Cooling: High pressure protection	○	○	○			

\* MUZ-GS•NAH/NAHZ only.

**MUZ-GS09NA MUZ-GS09NAH MUZ-GS09NAHZ MUY-GS09NA**  
**MUZ-GS12NA MUZ-GS12NAH MUZ-GS12NAHZ MUY-GS12NA**  
**MUZ-GS15NA MUZ-GS15NAH MUZ-GS15NAHZ MUY-GS15NA**  
**MUZ-GS18NA MUZ-GS18NAH MUZ-GS18NAHZ MUY-GS18NA**  
**MUZ-GS24NA MUZ-GS24NAH MUZ-GS24NAHZ MUY-GS24NA**  
**MUZ-GS30NA MUZ-GS30NAH MUY-GS30NA**  
**MUZ-GS30NA2 MUZ-GS30NAH2 MUY-GS30NA2**  
**MUZ-GS36NA MUZ-GS36NAH MUY-GS36NA**  
**MUZ-GS36NA2 MUZ-GS36NAH2 MUY-GS36NA2**

### 9-1. CHANGE IN DEFROST SETTING

Changing defrost finish temperature

<JS> To change the defrost finish temperature, cut/solder the JS wire of the outdoor inverter P.C. board (Refer to 10-6.1.).

Jumper		Defrost finish temperature		
		MUZ-GS09/12/15NA MUZ-GS09/12/15NAH MUZ-GS09/12/15NAHZ	MUZ-GS18/24NA MUZ-GS18/24NAH MUZ-GS18/24NAHZ	MUZ-GS30/36NA MUZ-GS30/36NAH MUZ-GS30/36NA2 MUZ-GS30/36NAH2
JS	Soldered (Initial setting)	41°F (5°C)	50°F (10°C) 50°F (10°C)	
	None (Cut)	50°F (10°C)	64°F (18°C) 64°F (18°C)	

### 9-2. PRE-HEAT CONTROL SETTING

Prolonged low load operation, in which the thermostat is OFF for a long time, at low outside temperature [32°F (0°C) or less] may cause the following troubles. To prevent those troubles, activate the pre-heat control.

- 1) If moisture gets into the refrigerant cycle and freezes, it may interfere the startup of the compressor.
- 2) If liquid refrigerant collects in the compressor, a failure in the compressor may occur.

The pre-heat control turns ON when the compressor temperature is 68°F (20°C) or below. When the pre-heat control turns ON, the compressor is energized. (About 70 W)

#### Pre-heat control setting

<JK>

ON: To activate the pre-heat control, cut JK wire of the inverter P.C. board.

OFF: To deactivate the pre-heat control, solder JK wire of the inverter P.C. board.

(Refer to 10-6.1)

Jumper		Pre-heat control setting		
		MUZ-GS09/12/15NA MUZ-GS09/12/15NAH MUZ-GS09/12/15NAHZ MUY-GS09/12/15NA	MUZ-GS18/24NA MUZ-GS18/24NAH MUZ-GS18/24NAHZ MUY-GS18/24NA	MUZ-GS30/36NA MUZ-GS30/36NAH MUY-GS30/36NA MUZ-GS30/36NA2 MUZ-GS30/36NAH2 MUY-GS30/36NA2
JK	Soldered	Deactivated (Initial setting)	Deactivated (Initial setting)	
	Cut	Activated	Activated	

**NOTE:** When the inverter P.C. board is replaced, check the jumper wires, and cut/solder them if necessary.

MUZ-GS09NA MUZ-GS09NAH MUZ-GS09NAHZ MUY-GS09NA  
 MUZ-GS12NA MUZ-GS12NAH MUZ-GS12NAHZ MUY-GS12NA  
 MUZ-GS15NA MUZ-GS15NAH MUZ-GS15NAHZ MUY-GS15NA  
 MUZ-GS18NA MUZ-GS18NAH MUZ-GS18NAHZ MUY-GS18NA  
 MUZ-GS24NA MUZ-GS24NAH MUZ-GS24NAHZ MUY-GS24NA  
 MUZ-GS30NA MUZ-GS30NAH MUY-GS30NA  
 MUZ-GS30NA2 MUZ-GS30NAH2 MUY-GS30NA2  
 MUZ-GS36NA MUZ-GS36NAH MUY-GS36NA  
 MUZ-GS36NA2 MUZ-GS36NAH2 MUY-GS36NA2

### 10-1. CAUTIONS ON TROUBLESHOOTING

#### 1. Before troubleshooting, check the following

- 1) Check the power supply voltage.
- 2) Check the indoor/outdoor connecting wire for miswiring.

#### 2. Take care of the following during servicing

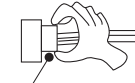
- 1) Before servicing the air conditioner, be sure to turn OFF the main unit first with the remote controller, then after confirming the horizontal vane is closed, turn off the breaker and/or disconnect the power plug.
- 2) Be sure to turn OFF the power supply before removing the front panel, the cabinet, the top panel, and the electronic control P.C. board.
- 3) When removing the electrical parts, be careful of the residual voltage of smoothing capacitor.
- 4) When removing the electronic control P.C. board, hold the edge of the board with care NOT to apply stress on the components.
- 5) When connecting or disconnecting the connectors, hold the connector housing. DO NOT pull the lead wires.

<Incorrect>



Lead wiring

<Correct>



Connector housing

#### 3. Troubleshooting procedure

- 1) Check if the OPERATION INDICATOR lamp on the indoor unit is blinking on and off to indicate an abnormality. To make sure, check how many times the OPERATION INDICATOR lamp is blinking on and off before starting service work.
- 2) Before servicing, verify that all connectors and terminals are connected properly.
- 3) When the electronic control P.C. board seems to be defective, check for disconnection of the copper foil pattern and burnt or discolored components.
- 4) Refer to 10-2 and 10-3.

## 10-2. FAILURE MODE RECALL FUNCTION

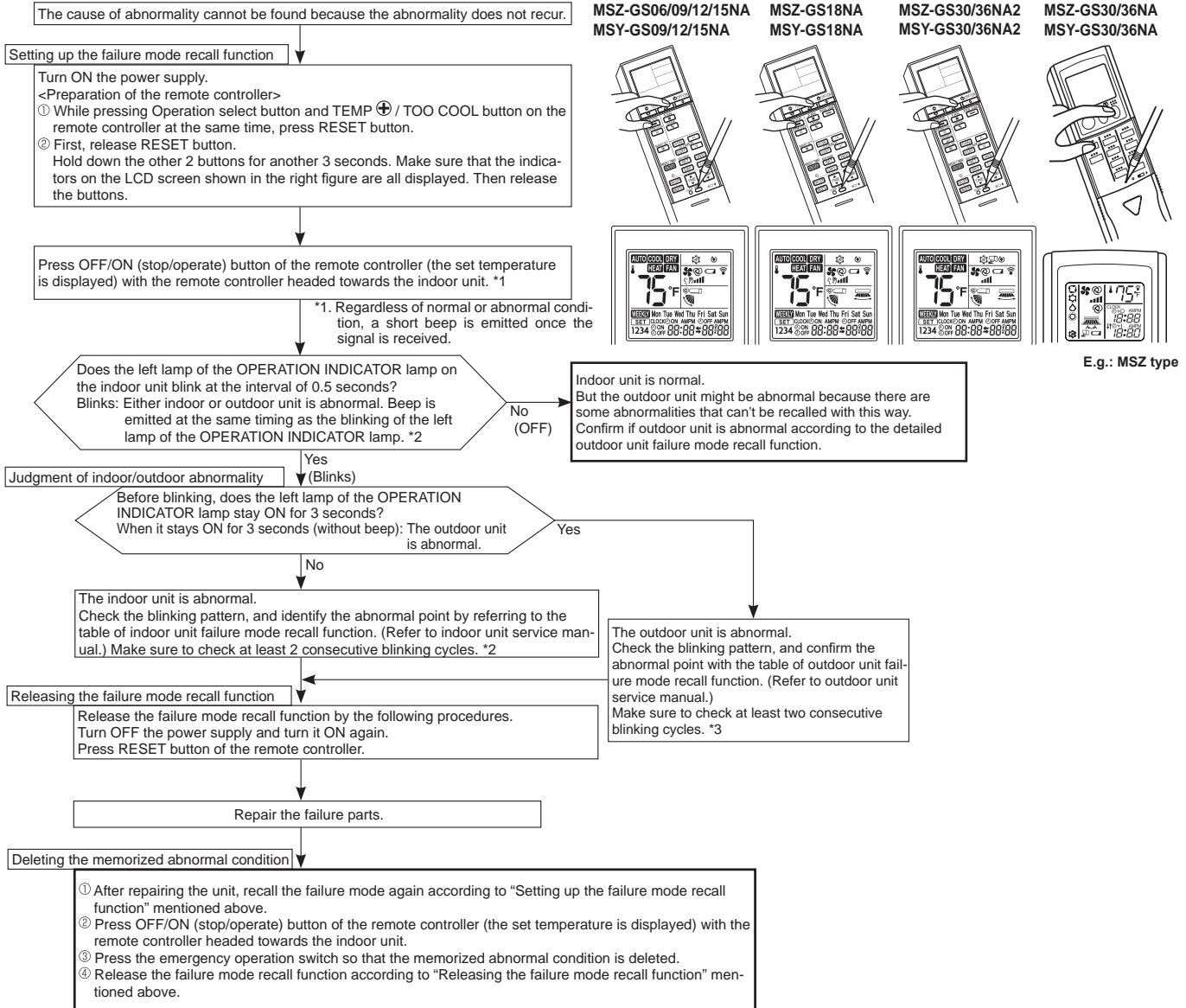
Outline of the function

This air conditioner can memorize the abnormal condition which has occurred once.

Even though LED indication listed on the troubleshooting check table (10-3.) disappears, the memorized failure details can be recalled.

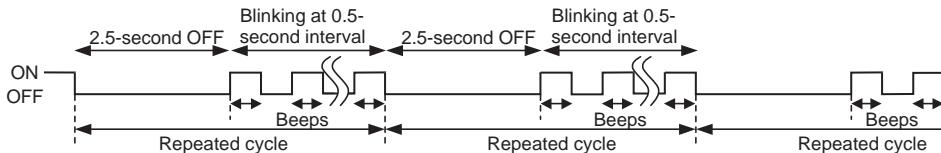
### 1. Flow chart of failure mode recall function for the indoor/outdoor unit

Operational procedure

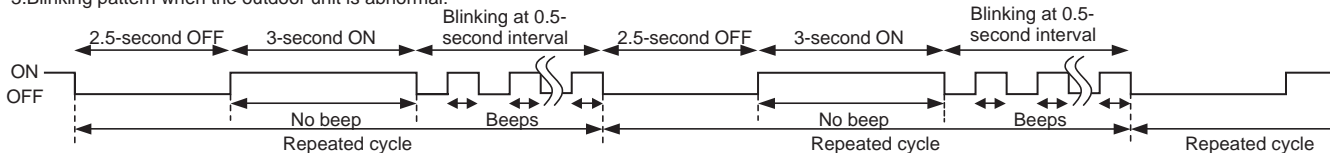


**NOTE:** 1. Make sure to release the failure mode recall function after it is set up, otherwise the unit cannot operate properly.  
 2. If the abnormal condition is not deleted from the memory, the last abnormal condition is kept memorized.

\*2. Blinking pattern when the indoor unit is abnormal:



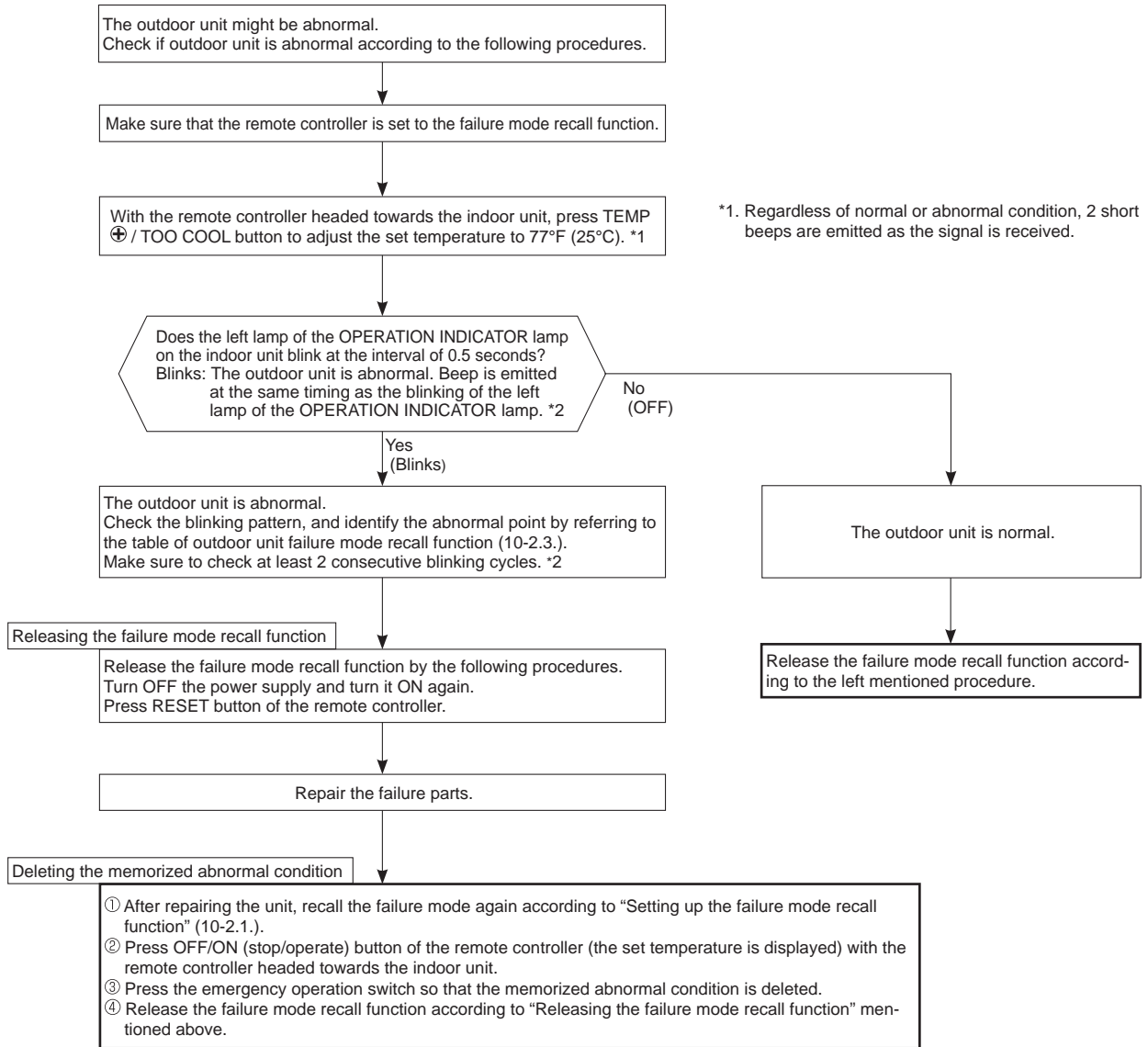
\*3. Blinking pattern when the outdoor unit is abnormal:





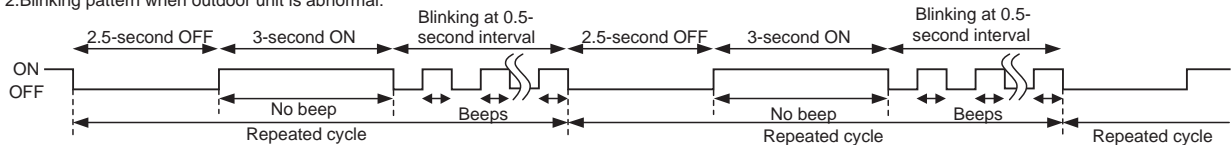
## 2. Flow chart of the detailed outdoor unit failure mode recall function

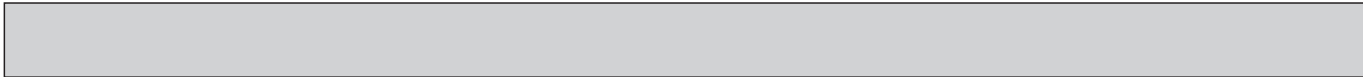
### Operational procedure



**NOTE:** 1. Make sure to release the failure mode recall function after it is set up, otherwise the unit cannot operate properly.  
2. If the abnormal condition is not deleted from the memory, the last abnormal condition is kept memorized.

\*2. Blinking pattern when outdoor unit is abnormal:





**NOTE:** Blinking patterns of this mode differ from the ones of TROUBLESHOOTING CHECK TABLE (10-3.).

**3. Table of outdoor unit failure mode recall function**

The left lamp of the OPERATION INDICATOR lamp (Indoor unit)	Abnormal point (Failure mode/protection)	LED indication (Outdoor P.C. board)	Condition	Remedy	Indoor/outdoor unit failure mode recall function	Outdoor unit failure mode recall function
OFF	None (Normal)	—	—	—	—	—
1-time blink 2.5 seconds OFF	Indoor/outdoor communication, receiving error	—	Any signals from the inverter P.C. board cannot be received normally for 3 minutes.	•Refer to 10-5. ㉞ How to check miswiring and serial signal error.	○	○
	Indoor/outdoor communication, receiving error	—	Although the inverter P.C. board sends signal "0", signal "1" has been received 30 consecutive times.	•Refer to 10-5. ㉞ How to check miswiring and serial signal error.		
2-time blink 2.5 seconds OFF	Outdoor power system	—	Overcurrent protection cut-out operates 3 consecutive times within 1 minute after the compressor gets started.	•Reconnect connectors. •Refer to 10-5. ㉞ "How to check inverter/compressor". •Check stop valve.	○	○
3-time blink 2.5 seconds OFF	Discharge temperature thermistor	1-time blink every 2.5 seconds	Thermistor shorts or opens during compressor running.	•Refer to 10-5. ㉞ "Check of outdoor thermistors". Defective outdoor thermistors can be identified by checking the blinking pattern of LED.  •Replace the inverter P.C. board.	○	○
	Defrost thermistor					
	Fin temperature thermistor	3-time blink 2.5 seconds OFF				
	Ambient temperature thermistor	2-time blink 2.5 seconds OFF				
	Outdoor heat exchanger temperature thermistor	—				
	P.C. board temperature thermistor	4-time blink 2.5 seconds OFF				
4-time blink 2.5 seconds OFF	Overcurrent	11-time blink 2.5 seconds OFF	Large current flows into the power module (IC700).	•Reconnect compressor connector. •Refer to 10-5. ㉞ "How to check inverter/compressor". •Check stop valve.	—	○
	Compressor synchronous abnormality (Compressor startup failure protection)	12-time blink 2.5 seconds OFF	Waveform of compressor current is distorted.	•Reconnect compressor connector. •Refer to 10-5. ㉞ "How to check inverter/compressor".	—	○
5-time blink 2.5 seconds OFF	Discharge temperature	—	Temperature of discharge temperature thermistor exceeds 241°F (116°C), compressor stops. Compressor can restart if discharge temperature thermistor reads 212°F (100°C) or less 3 minutes later.	•Check refrigerant circuit and refrigerant amount. •Refer to 10-5. ㉞ "Check of LEV".	—	○
6-time blink 2.5 seconds OFF	High pressure	—	Temperature indoor coil thermistor exceeds 158°F (70°C) in HEAT mode. Temperature defrost thermistor exceeds 158°F (70°C) in COOL mode.	•Check refrigerant circuit and refrigerant amount. •Check stop valve.	—	○
7-time blink 2.5 seconds OFF	Fin temperature/ P.C. board temperature	7-time blink 2.5 seconds OFF	Temperature of the fin temperature thermistor on the inverter P.C. board exceeds 167 - 187°F (75 - 86°C) (GS09/12/15/18)/167 - 176°F (75 - 80°C) (GS24/30/36), or temperature of P.C. board temperature thermistor on the inverter P.C. board exceeds 162 - 185°F (72 - 85°C) (GS09/12/15/18)/158 - 167°F (70 - 75°C) (GS24/30/36).	•Check around outdoor unit. •Check outdoor unit air passage. •Refer to 10-5. ㉞ "Check of outdoor fan motor".	—	○
8-time blink 2.5 seconds OFF	Outdoor fan motor	—	Outdoor fan has stopped 3 times in a row within 30 seconds after outdoor fan startup.	•Refer to 10-5. ㉞ "Check of outdoor fan motor". Refer to 10-5. ㉞ "Check of inverter P.C. board".	—	○
9-time blink 2.5 seconds OFF	Nonvolatile memory data	5-time blink 2.5 seconds OFF	Nonvolatile memory data cannot be read properly.	•Replace the inverter P.C. board.	○	○
	Power module (IC700)	6-time blink 2.5 seconds OFF	The interface short circuit occurs in the output of the power module (IC700). The compressor winding shorts circuit.	•Refer to 10-5. ㉞ "How to check inverter/compressor".	—	

**NOTE:** Blinking patterns of this mode differ from the ones of TROUBLESHOOTING CHECK TABLE (10-3.).

The left lamp of the OPERATION INDICATOR lamp (Indoor unit)	Abnormal point (Failure mode/protection)	LED indication (Outdoor P.C. board)	Condition	Remedy	Indoor/outdoor unit failure mode recall function	Outdoor unit failure mode recall function
10-time blink 2.5 seconds OFF	Discharge temperature	—	Temperature of discharge temperature thermistor has been 122°F (50°C) or less for 20 minutes.	<ul style="list-style-type: none"> <li>Refer to 10-5.Ⓚ "Check of LEV".</li> <li>Check refrigerant circuit and refrigerant amount.</li> </ul>	—	○
11-time blink 2.5 seconds OFF	Bus-bar voltage (DC)	8-time blink 2.5 seconds OFF	Bus-bar voltage of inverter cannot be detected normally.	<ul style="list-style-type: none"> <li>Refer to 10-5.Ⓐ "How to check inverter/compressor".</li> </ul>	—	○
	Each phase current of compressor	9-time blink 2.5 seconds OFF	Each phase current of compressor cannot be detected normally.			
14-time blink 2.5 seconds OFF *1	Stop valve (Closed valve)	14-time blink 2.5 seconds OFF	<ul style="list-style-type: none"> <li>Closed valve is detected by compressor current.</li> <li>An abnormality of the indoor thermistors, the defrost thermistor or ambient temperature thermistor is detected.</li> </ul>	<ul style="list-style-type: none"> <li>Check stop valve.</li> <li>Refer to "TEST POINT DIAGRAM AND VOLTAGE" on the service manual of indoor and outdoor unit for the characteristics of the thermistors. (Do not start the operation again without repair to prevent hazards.)</li> </ul>	○	○
	4-way valve/ Pipe temperature	16-time blink 2.5 seconds OFF	<ul style="list-style-type: none"> <li>The 4-way valve does not work properly.</li> <li>The indoor coil thermistor detects an abnormal temperature.</li> <li>An abnormality of the indoor thermistor is detected.</li> </ul>	<ul style="list-style-type: none"> <li>Check the 4-way valve.</li> <li>Replace the inverter P.C. board.</li> <li>Refer to "TEST POINT DIAGRAM AND VOLTAGE" on the service manual of indoor and outdoor unit for the characteristics of the thermistors. (Do not start the operation again without repair to prevent hazards.)</li> </ul>		
16-time blink 2.5 seconds OFF *1	Outdoor refrigerant system abnormality	1-time blink 2.5 seconds OFF	<ul style="list-style-type: none"> <li>A closed valve and air trapped in the refrigerant circuit are detected based on the temperature sensed by the indoor and outdoor thermistors and the current of the compressor.</li> <li>An abnormality of the indoor thermistors, the defrost thermistor or ambient temperature thermistor is detected.</li> </ul>	<ul style="list-style-type: none"> <li>Check for a gas leak in a connecting piping etc.</li> <li>Check the stop valve.</li> <li>Refer to 10-5.Ⓞ "Check of outdoor refrigerant circuit".</li> <li>Refer to "TEST POINT DIAGRAM AND VOLTAGE" on the service manual of indoor and outdoor unit for the characteristics of the thermistors. (Do not start the operation again without repair to prevent hazards.)</li> </ul>	○	○

\*1 There is possibility that diesel explosion may occur due to the air mixed in the refrigerant circuit.

First, ensure that there are no leakage points on the valves, flare connections, etc. that allow the air to flow into the refrigerant circuit, or no blockage points (e.g. clogged or closed valves) in the refrigerant circuit that cause an increase in pressure.

If there is no abnormal point like above and the system operates cooling and heating modes normally, the indoor thermistor might have a problem, resulting in false detection.

Check both the indoor coil thermistor and the room temperature thermistor, and replace faulty thermistor(s), if any.

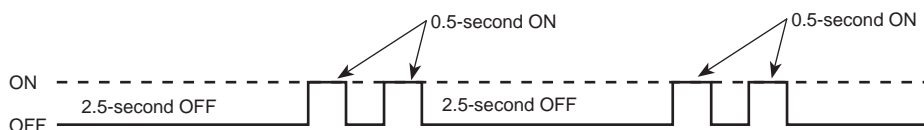
**NOTE:** Do not start the operation again without repair to prevent hazards.

### 10-3. TROUBLESHOOTING CHECK TABLE

No.	Symptom	LED indication	Abnormal point/ Condition	Condition	Remedy	
1	Outdoor unit does not operate.	1-time blink every 2.5 seconds	Outdoor power system	Overcurrent protection cut-out operates 3 consecutive times within 1 minute after the compressor gets started.	<ul style="list-style-type: none"> <li>Reconnect connector of compressor.</li> <li>Refer to 10-5.④ "How to check inverter/compressor".</li> <li>Check stop valve.</li> </ul>	
2			Outdoor thermistors	Discharge temperature thermistor, fin temperature thermistor, defrost thermistor, outdoor heat exchanger temperature thermistor or ambient temperature thermistor shorts or opens during compressor running.	<ul style="list-style-type: none"> <li>Refer to 10-5.④ "Check of outdoor thermistors".</li> </ul>	
3			Outdoor control system	P.C. board temperature thermistor shorts or opens during compressor running.	<ul style="list-style-type: none"> <li>Replace inverter P.C. board.</li> </ul>	
3			Outdoor control system	Nonvolatile memory data cannot be read properly.  (The left lamp of the OPERATION INDICATOR lamp on the indoor unit lights up or blinks 7-time.)	<ul style="list-style-type: none"> <li>Replace inverter P.C. board.</li> </ul>	
4			6-time blink 2.5 seconds OFF	Serial signal	The communication fails between the indoor and outdoor unit for 3 minutes.	<ul style="list-style-type: none"> <li>Refer to 10-5.④ "How to check miswiring and serial signal error."</li> </ul>
5			11-time blink 2.5 seconds OFF	Stop valve/ Closed valve	Closed valve is detected by compressor current.	<ul style="list-style-type: none"> <li>Check stop valve.</li> </ul>
6			16-time blink 2.5 seconds OFF	4-way valve/ Pipe temperature	The 4-way valve does not work properly. The indoor coil thermistor detects an abnormal temperature.	<ul style="list-style-type: none"> <li>Refer to 10-5.④ "Check of R.V. coil".</li> <li>Replace the inverter P.C. board.</li> </ul>
7	17-time blink 2.5 seconds OFF	Outdoor refrigerant system abnormality	A closed valve and air trapped in the refrigerant circuit are detected based on the temperature sensed by the indoor and outdoor thermistors and the current of the compressor.	<ul style="list-style-type: none"> <li>Check for a gas leak in a connecting piping etc.</li> <li>Check the stop valve.</li> <li>Refer to 10-5.④ "Check of outdoor refrigerant circuit".</li> </ul>		
8	'Outdoor unit stops and restarts 3 minutes later' is repeated.	2-time blink 2.5 seconds OFF	Overcurrent protection	Large current flows into the power module (IC700).	<ul style="list-style-type: none"> <li>Reconnect connector of compressor.</li> <li>Refer to 10-5.④ "How to check inverter/compressor".</li> <li>Check stop valve.</li> </ul>	
9		3-time blink 2.5 seconds OFF	Discharge temperature overheat protection	Temperature of discharge temperature thermistor exceeds 241°F (116°C), compressor stops. Compressor can restart if discharge temperature thermistor reads 212°F (100°C) or less 3 minutes later.	<ul style="list-style-type: none"> <li>Check refrigerant circuit and refrigerant amount.</li> <li>Refer to 10-5.④ "Check of LEV".</li> </ul>	
10		4-time blink 2.5 seconds OFF	Fin temperature /P.C. board temperature thermistor overheat protection	Temperature of the fin temperature thermistor on the heat sink exceeds 167 - 187°F (75 - 86°C) (GS09/12/15/18)/167 - 176°F (75 - 80°C) (GS18NAHZ, GS24/30/36) or temperature of P.C. board temperature thermistor on the inverter P.C. board exceeds 162 - 185°F (72 - 85°C) (GS09/12/15/18)/158 - 167°F (70 - 75°C) (GS18NAHZ, GS24/30/36).	<ul style="list-style-type: none"> <li>Check around outdoor unit.</li> <li>Check outdoor unit air passage.</li> <li>Refer to 10-5.④ "Check of outdoor fan motor".</li> </ul>	
11		5-time blink 2.5 seconds OFF	High pressure protection	Indoor coil thermistor exceeds 158°F (70°C) in HEAT mode. Defrost thermistor exceeds 158°F (70°C) in COOL mode.	<ul style="list-style-type: none"> <li>Check refrigerant circuit and refrigerant amount.</li> <li>Check stop valve.</li> </ul>	
12		8-time blink 2.5 seconds OFF	Compressor synchronous abnormality	The waveform of compressor current is distorted.	<ul style="list-style-type: none"> <li>Reconnect connector of compressor.</li> <li>Refer to 10-5.④ "How to check inverter/compressor".</li> </ul>	
13		10-time blink 2.5 seconds OFF	Outdoor fan motor	Outdoor fan has stopped 3 times in a row within 30 seconds after outdoor fan startup.	<ul style="list-style-type: none"> <li>Refer to 10-5.④ "Check of outdoor fan motor."</li> <li>Refer to 10-5.④ "Check of inverter P.C. board."</li> </ul>	
14		12-time blink 2.5 seconds OFF	Each phase current of compressor	Each phase current of compressor cannot be detected normally.	<ul style="list-style-type: none"> <li>Refer to 10-5.④ "How to check inverter/compressor".</li> </ul>	
15		13-time blink 2.5 seconds OFF	Bus-bar voltage (DC)	Bus-bar voltage of inverter cannot be detected normally.	<ul style="list-style-type: none"> <li>It occurs with following case.</li> <li>Instantaneous power voltage drop. (Short time power failure)</li> <li>Refer to 10-5.④ "Check of power supply".</li> <li>Refer to 10-5.④ "How to check inverter/compressor".</li> </ul>	

**NOTE:** 1. The location of LED is illustrated at the right figure. Refer to 10-6.1.  
2. LED is lit during normal operation.

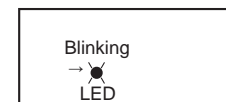
The blinking frequency shows the number of times the LED blinks after every 2.5-second OFF.  
(Example) When the blinking frequency is "2".



Inverter P.C. board  
**MUZ-GS09/12/15/18NA**  
**MUZ-GS09/12/15/18NAH**  
**MUZ-GS09/12/15NAHZ**  
**MUY-GS09/12/15/18NA**



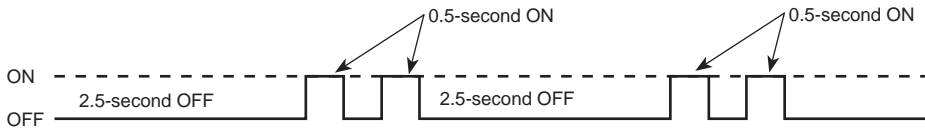
**MUZ-GS24/30/36NA**  
**MUZ-GS24/30/36NAH**  
**MUZ-GS18/24NAHZ**  
**MUY-GS24/30/36NA**  
**MUZ-GS30/36NA2**  
**MUZ-GS30/36NAH2**  
**MUY-GS30/36NA2**



No.	Symptom	LED indication	Abnormal point/ Condition	Condition	Remedy
16	Outdoor unit operates.	1-time blink 2.5 seconds OFF	Deceleration of the operational frequency of the compressor by the current protection control	<b>GS09/12/15/18</b> When the input current exceeds approximately 10A ( <b>GS09</b> )/10.5A ( <b>GS12/15/18</b> ), compressor frequency lowers.	The unit is normal, but check the following. • Check if indoor filters are clogged. • Check if refrigerant is short. • Check if indoor/outdoor unit air circulation is short cycled.
				<b>GS18NAHZ</b> <b>GS24/30/36</b> Current from power outlet is nearing breaker capacity.	
17		3-time blink 2.5 seconds OFF	Deceleration of the operational frequency of the compressor by the high pressure protection	Temperature of indoor coil thermistor exceeds 131 °F (55°C) in HEAT mode, compressor frequency lowers.	
				Indoor coil thermistor reads 46°F (8°C) or less in COOL mode, compressor frequency lowers.	
18		4-time blink 2.5 seconds OFF	Deceleration of the operational frequency of the compressor by the discharge temperature protection	Temperature of discharge temperature thermistor exceeds 232°F (111°C), compressor frequency lowers.	• Check refrigerant circuit and refrigerant amount. • Refer to 10-5.Ⓢ "Check of LEV". • Refer to 10-5.Ⓢ "Check of outdoor thermistors".
19		<b>MUZ-GS09/12/15/18</b> 5-time blink 2.5 seconds OFF	Outside temperature thermistor protection	When the outside temperature thermistor shorts or opens, protective operation without that thermistor is performed.	• Refer to 10-5.Ⓢ Check of outdoor thermistors.
20	Outdoor unit operates.	7-time blink 2.5 seconds OFF	Low discharge temperature protection	Temperature of discharge temperature thermistor has been 122°F (50°C) or less for 20 minutes.	• Refer to 10-5.Ⓢ "Check of LEV". • Check refrigerant circuit and refrigerant amount.
21		8-time blink 2.5 seconds OFF	Zero cross detecting circuit	Zero cross signal cannot be detected.	• It occurs with following cases. 1 Instantaneous power voltage drop. (Short time power failure) 2 Distortion of primary voltage • Refer to 10-5.Ⓢ "Check of power supply".
22		9-time blink 2.5 seconds OFF	Inverter check mode	The connector of compressor is disconnected, inverter check mode starts.	• Check if the connector of the compressor is correctly connected. Refer to 10-5.Ⓢ "How to check inverter/compressor".

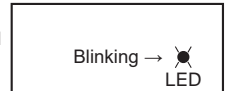
**NOTE:** 1. The location of LED is illustrated at the right figure. Refer to 10-6.1.  
2. LED is lit during normal operation.

The blinking frequency shows the number of times the LED blinks after every 2.5-second OFF.  
(Example) When the blinking frequency is "2".

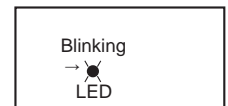


Inverter P.C. board

**MUZ-GS09/12/15/18NA**  
**MUZ-GS09/12/15/18NAH**  
**MUZ-GS09/12/15NAHZ**  
**MUY-GS09/12/15/18NA**

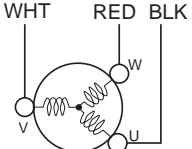
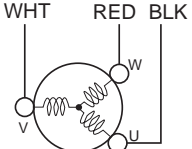
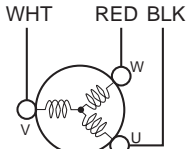
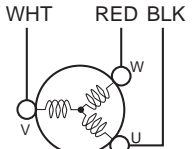


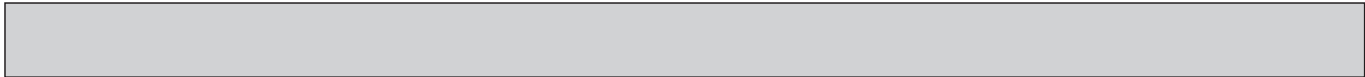
**MUZ-GS24/30/36NA**  
**MUZ-GS24/30/36NAH**  
**MUY-GS24/30/36NA**  
**MUZ-GS30/36NA2**  
**MUZ-GS30/36NAH2**  
**MUY-GS30/36NA2**

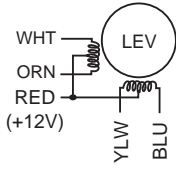


**10-4. TROUBLESHOOTING CRITERION OF MAIN PARTS**

**MUZ-GS09NA MUZ-GS09NAH MUZ-GS09NAHZ MUY-GS09NA  
 MUZ-GS12NA MUZ-GS12NAH MUZ-GS12NAHZ MUY-GS12NA  
 MUZ-GS15NA MUZ-GS15NAH MUZ-GS15NAHZ MUY-GS15NA  
 MUZ-GS18NA MUZ-GS18NAH MUZ-GS18NAHZ MUY-GS18NA  
 MUZ-GS24NA MUZ-GS24NAH MUZ-GS24NAHZ MUY-GS24NA  
 MUZ-GS30NA MUZ-GS30NAH MUY-GS30NA  
 MUZ-GS30NA2 MUZ-GS30NAH2 MUY-GS30NA2  
 MUZ-GS36NA MUZ-GS36NAH MUY-GS36NA  
 MUZ-GS36NA2 MUZ-GS36NAH2 MUY-GS36NA2**

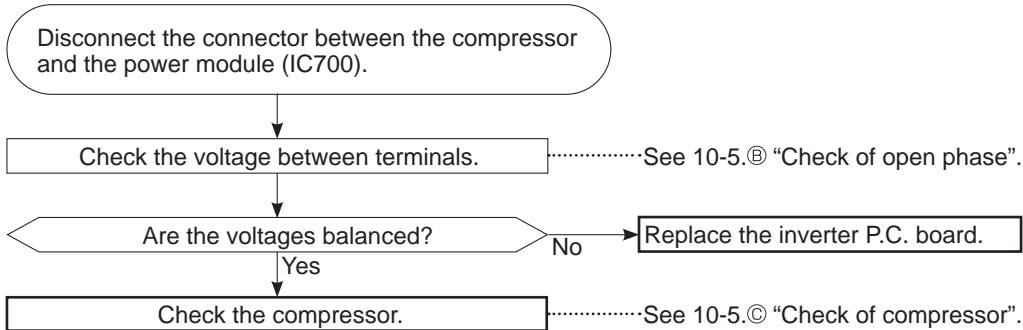
Part name	Check method and criterion	Figure																					
Defrost thermistor (RT61) Fin temperature thermistor (RT64) Ambient temperature thermistor (RT65) Outdoor heat exchanger temperature thermistor (RT68)	Measure the resistance with a multimeter.  Refer to 10-6. "Test point diagram and voltage", 1. "Inverter P.C. board", for the chart of thermistor.																						
Discharge temperature thermistor (RT62)	Measure the resistance with a multimeter. Before measurement, hold the thermistor with your hands to warm it up.  Refer to 10-6. "Test point diagram and voltage", 1. "Inverter P.C. board", for the chart of thermistor.																						
Compressor	Measure the resistance between terminals using a multimeter. [Temperature: 14 - 104°F (-10 - 40°C)]																						
	<table border="1" style="width: 100%; border-collapse: collapse;"> <thead> <tr> <th rowspan="2"></th> <th colspan="3">Normal (Ω)</th> </tr> <tr> <th>MUZ-GS09NA/NAH/NAHZ MUZ-GS12NA/NAH MUY-GS09/12NA</th> <th>MUZ-GS12NAHZ MUZ-GS15NA/NAH/NAHZ MUY-GS15NA</th> <th>MUZ-GS18NA/NAH MUY-GS18NA</th> </tr> </thead> <tbody> <tr> <td>U-V</td> <td rowspan="3" style="text-align: center;">1.60 - 2.17</td> <td rowspan="3" style="text-align: center;">1.66 - 2.26</td> <td rowspan="3" style="text-align: center;">0.82 - 1.11</td> </tr> <tr> <td>U-W</td> </tr> <tr> <td>V-W</td> </tr> </tbody> </table> <table border="1" style="width: 100%; border-collapse: collapse;"> <thead> <tr> <th rowspan="2"></th> <th colspan="2">Normal (Ω)</th> </tr> <tr> <th>MUZ-GS18NAHZ MUZ-GS24NA/NAH/NAHZ MUY-GS24NA</th> <th>MUZ-GS30/36 MUY-GS30/36</th> </tr> </thead> <tbody> <tr> <td>U-V</td> <td rowspan="3" style="text-align: center;">0.87 - 1.18</td> <td rowspan="3" style="text-align: center;">1.38 - 1.87</td> </tr> <tr> <td>U-W</td> </tr> <tr> <td>V-W</td> </tr> </tbody> </table>			Normal (Ω)			MUZ-GS09NA/NAH/NAHZ MUZ-GS12NA/NAH MUY-GS09/12NA	MUZ-GS12NAHZ MUZ-GS15NA/NAH/NAHZ MUY-GS15NA	MUZ-GS18NA/NAH MUY-GS18NA	U-V	1.60 - 2.17	1.66 - 2.26	0.82 - 1.11	U-W	V-W		Normal (Ω)		MUZ-GS18NAHZ MUZ-GS24NA/NAH/NAHZ MUY-GS24NA	MUZ-GS30/36 MUY-GS30/36	U-V	0.87 - 1.18	1.38 - 1.87
	Normal (Ω)																						
	MUZ-GS09NA/NAH/NAHZ MUZ-GS12NA/NAH MUY-GS09/12NA	MUZ-GS12NAHZ MUZ-GS15NA/NAH/NAHZ MUY-GS15NA	MUZ-GS18NA/NAH MUY-GS18NA																				
U-V	1.60 - 2.17	1.66 - 2.26	0.82 - 1.11																				
U-W																							
V-W																							
	Normal (Ω)																						
	MUZ-GS18NAHZ MUZ-GS24NA/NAH/NAHZ MUY-GS24NA	MUZ-GS30/36 MUY-GS30/36																					
U-V	0.87 - 1.18	1.38 - 1.87																					
U-W																							
V-W																							
Outdoor fan motor	Measure the resistance between lead wires using a multimeter. [Temperature: 14 - 104°F (-10 - 40°C)]																						
	<table border="1" style="width: 100%; border-collapse: collapse;"> <thead> <tr> <th rowspan="2">Color of lead wire</th> <th colspan="2">Normal (Ω)</th> </tr> <tr> <th>MUZ-GS09/12/15 MUY-GS09/12/15</th> <th>MUZ-GS18/24/30/36 MUY-GS18/24/30/36</th> </tr> </thead> <tbody> <tr> <td>RED - BLK BLK - WHT WHT - RED</td> <td style="text-align: center;">29 - 37</td> <td style="text-align: center;">8 - 10</td> </tr> </tbody> </table>		Color of lead wire	Normal (Ω)		MUZ-GS09/12/15 MUY-GS09/12/15	MUZ-GS18/24/30/36 MUY-GS18/24/30/36	RED - BLK BLK - WHT WHT - RED	29 - 37	8 - 10													
Color of lead wire	Normal (Ω)																						
	MUZ-GS09/12/15 MUY-GS09/12/15	MUZ-GS18/24/30/36 MUY-GS18/24/30/36																					
RED - BLK BLK - WHT WHT - RED	29 - 37	8 - 10																					
R. V. coil (21S4)	Measure the resistance using a multimeter. [Temperature: 14 - 104°F (-10 - 40°C)]																						
	<table border="1" style="width: 100%; border-collapse: collapse;"> <thead> <tr> <th>Normal (kΩ)</th> </tr> </thead> <tbody> <tr> <td style="text-align: center;"><b>MUZ</b></td> </tr> <tr> <td style="text-align: center;">0.97 - 1.38</td> </tr> </tbody> </table>	Normal (kΩ)	<b>MUZ</b>	0.97 - 1.38																			
Normal (kΩ)																							
<b>MUZ</b>																							
0.97 - 1.38																							



Part name	Check method and criterion	Figure								
Expansion valve coil (LEV)	Measure the resistance using a multimeter. [Temperature: 14 - 104°F (-10 - 40°C)] <table border="1" data-bbox="448 321 901 485"> <thead> <tr> <th>Color of lead wire</th> <th>Normal (Ω)</th> </tr> </thead> <tbody> <tr> <td>RED - ORN</td> <td rowspan="5">37 - 54</td> </tr> <tr> <td>RED - WHT</td> </tr> <tr> <td>RED - BLU</td> </tr> <tr> <td>RED - YLW</td> </tr> <tr> <td>RED - YLW</td> </tr> </tbody> </table>	Color of lead wire	Normal (Ω)	RED - ORN	37 - 54	RED - WHT	RED - BLU	RED - YLW	RED - YLW	
Color of lead wire	Normal (Ω)									
RED - ORN	37 - 54									
RED - WHT										
RED - BLU										
RED - YLW										
RED - YLW										
Defrost heater	Measure the resistance using a multimeter. [Temperature: 14 - 104°F (-10 - 40°C)] <table border="1" data-bbox="448 554 1134 699"> <thead> <tr> <th colspan="2">Normal (Ω)</th> </tr> </thead> <tbody> <tr> <td><b>MUZ-GS09/12/15NAH</b> <b>MUZ-GS09/12/15NAHZ</b></td> <td><b>MUZ-GS18/24/30/36NAH</b> <b>MUZ-GS18/24NAHZ</b> <b>MUZ-GS30/36NAH2</b></td> </tr> <tr> <td>349 - 428</td> <td>376 - 461</td> </tr> </tbody> </table>	Normal (Ω)		<b>MUZ-GS09/12/15NAH</b> <b>MUZ-GS09/12/15NAHZ</b>	<b>MUZ-GS18/24/30/36NAH</b> <b>MUZ-GS18/24NAHZ</b> <b>MUZ-GS30/36NAH2</b>	349 - 428	376 - 461			
Normal (Ω)										
<b>MUZ-GS09/12/15NAH</b> <b>MUZ-GS09/12/15NAHZ</b>	<b>MUZ-GS18/24/30/36NAH</b> <b>MUZ-GS18/24NAHZ</b> <b>MUZ-GS30/36NAH2</b>									
349 - 428	376 - 461									

## 10-5. TROUBLESHOOTING FLOW

### A How to check inverter/compressor



### B Check of open phase

- With the connector between the compressor and the power module (IC700) disconnected, activate the inverter and check if the inverter is normal by measuring **the voltage balance** between the terminals.

Output voltage is 50 - 130 V. (The voltage may differ according to the multimeter.)

<< Operation method >>

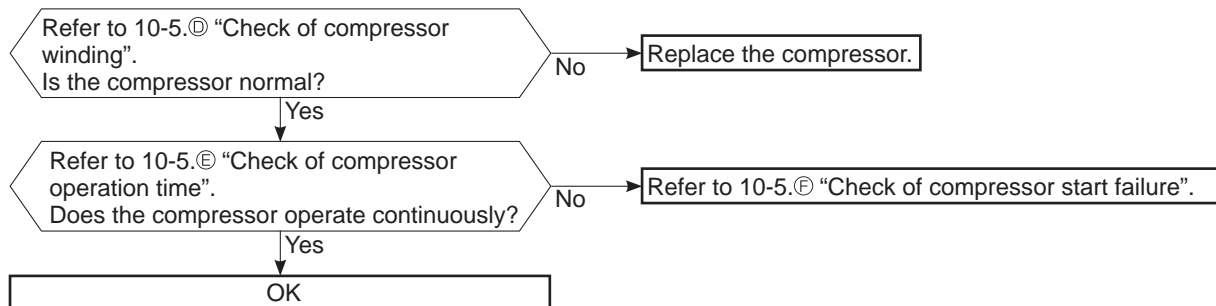
Start cooling or heating operation by pressing the emergency operation switch on the indoor unit. (TEST RUN OPERATION: Refer to 7-6.)

<< Measurement point >>

At 3 points \*Measure AC voltage between the lead wires at 3 points.  
 BLK (U)-WHT (V)  
 BLK (U)-RED (W)  
 WHT(V)-RED (W)

- NOTE:** 1. Output voltage varies according to power supply voltage.  
 2. Measure the voltage by analog type multimeter.  
 3. During this check, LED of the inverter P.C. board blinks 9 times. (Refer to 10-6.1.)

### C Check of compressor





### D Check of compressor winding

● Disconnect the connector between the compressor and the power module (IC700), and measure the resistance between the compressor terminals.

<<Measurement point>>

- At 3 points \*Measure the resistance between the lead wires at 3 points.
- BLK-WHT
- BLK-RED
- WHT-RED

<<Judgement>>

- Refer to 10-4.
- 0 [Ω] ..... Abnormal [short]
- Infinite [Ω] ..... Abnormal [open]

**NOTE:** Be sure to zero the ohmmeter before measurement.

### E Check of compressor operation time

● Connect the compressor and activate the inverter. Then measure the time until the inverter stops due to overcurrent.

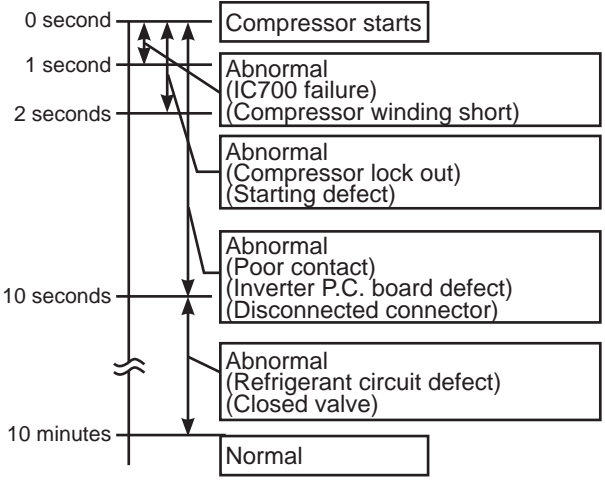
<<Operation method>>

Start heating or cooling operation by pressing the emergency operation switch on the indoor unit. (TEST RUN OPERATION: Refer to 7-6.)

<<Measurement>>

Measure the time from the start of compressor to the stop of compressor due to overcurrent.

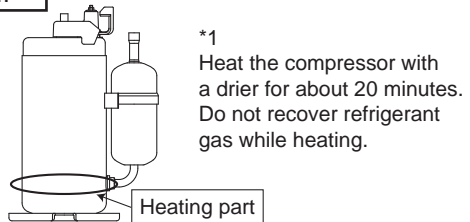
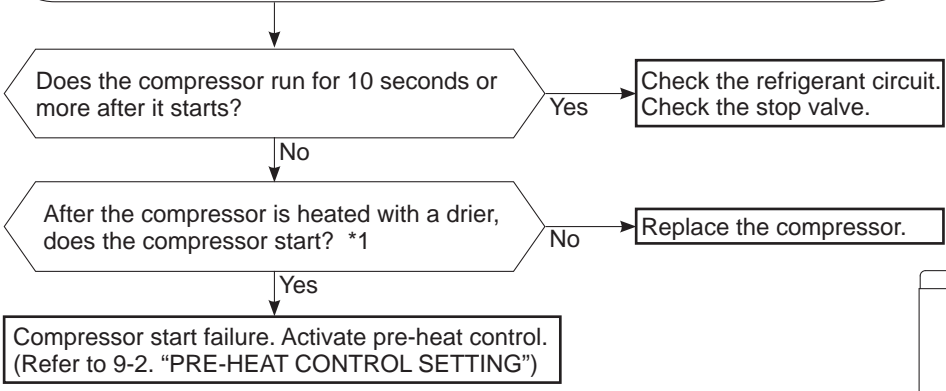
<<Judgement>>



### F Check of compressor start failure

Confirm that ①~④ is normal.

- Electrical circuit check
- ①. Contact of the compressor connector
- ②. Output voltage of inverter P.C. board and balance of them (See 10-5.⑥)
- ③. Direct current voltage between DB61(+) and (-) (MUZ-GS09/12/15/18)/IC700(P) and (N) (MUZ-GS18/24/30/36) on the inverter P.C. board
- ④. Voltage between outdoor terminal block S1-S2



\*1 Heat the compressor with a drier for about 20 minutes. Do not recover refrigerant gas while heating.

### Ⓒ Check of outdoor thermistors

Disconnect the connector of thermistor in the inverter P.C. board (see below table), and measure the resistance of thermistor.

Is the resistance of thermistor normal?  
(Refer to 10-6.1.)

No

Replace the thermistor except RT64.  
When RT64 is abnormal, replace the inverter P.C. board.

Yes

Reconnect the connector of thermistor.  
Turn ON the power supply and press the emergency operation switch.

Does the unit operate for 10 minutes or more  
without showing thermistor abnormality?

No

Replace the inverter P.C. board.

Yes

OK  
(Cause is poor contact.)

#### MUZ-GS09/12/15/18 MUY-GS09/12/15/18

Thermistor	Symbol	Connector, Pin No.	Board
Defrost	RT61	Between CN641 pin1 and pin2	Inverter P.C. board
Discharge temperature	RT62	Between CN641 pin3 and pin4	
Fin temperature	RT64	Between CN642 pin1 and pin2	
Ambient temperature	RT65	Between CN643 pin1 and pin2	
Outdoor heat exchanger temperature	RT68	Between CN644 pin1 and pin3	

#### MUZ-GS18/24/30/36 MUY-GS24/30/36

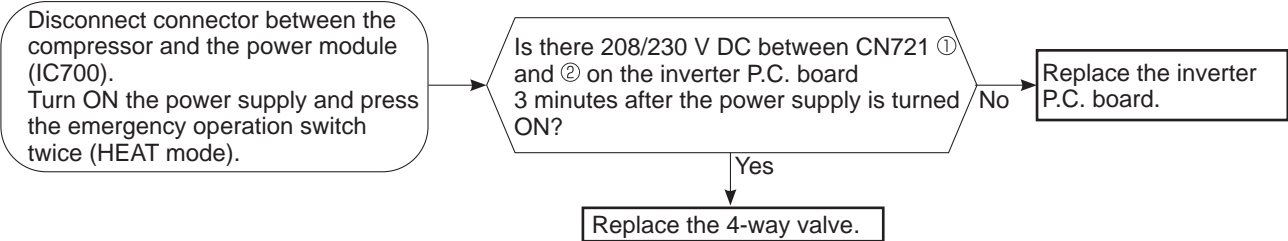
Thermistor	Symbol	Connector, Pin No.	Board
Defrost	RT61	Between CN671 pin1 and pin2	Inverter P.C. board
Discharge temperature	RT62	Between CN671 pin3 and pin4	
Fin temperature	RT64	Between CN673 pin1 and pin2	
Ambient temperature	RT65	Between CN672 pin1 and pin2	
Outdoor heat exchanger temperature	RT68	Between CN671 pin5 and pin6	

**H Check of R.V. coil**

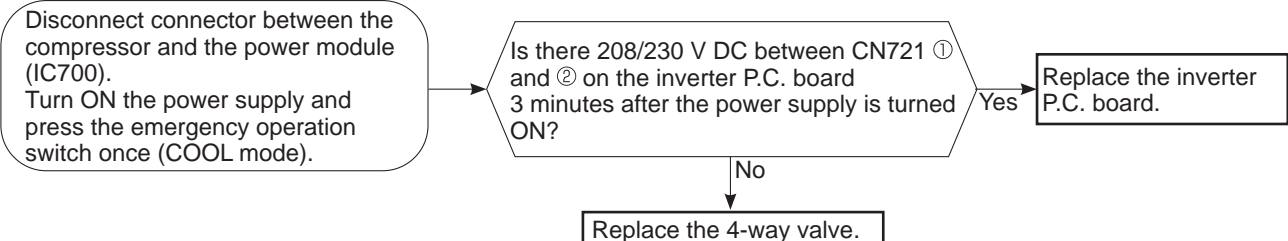
**MUZ-GS09/12/15/18**

- \* First of all, measure the resistance of R.V. coil to check if the coil is defective. Refer to 10-4.
- \* In case CN721 is disconnected or R.V. coil is open, voltage is generated between the terminal pins of the connector although no signal is being transmitted to R.V. coil. Check if CN721 is connected.

**Unit operates in COOL mode even if it is set to HEAT mode.**



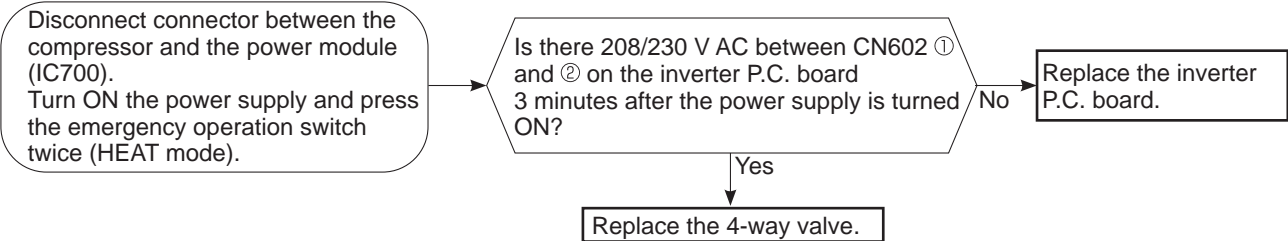
**Unit operates in HEAT mode even if it is set to COOL mode.**



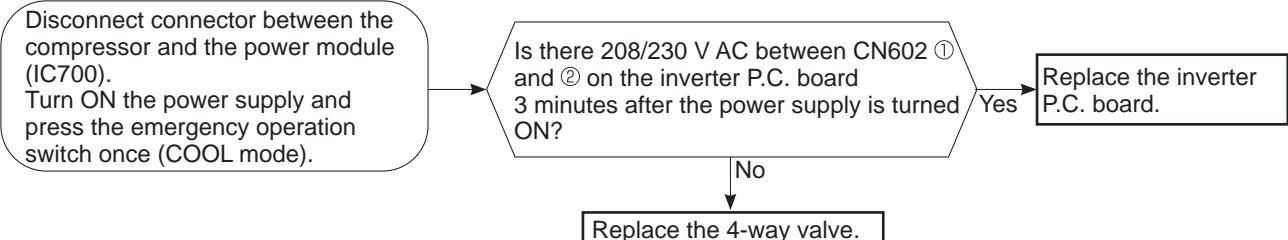
**MUZ-GS24/30/36**

- \* First of all, measure the resistance of R.V. coil to check if the coil is defective. Refer to 10-4.
- \* In case CN602 is disconnected or R.V. coil is open, voltage is generated between the terminal pins of the connector although no signal is being transmitted to R.V. coil. Check if CN602 is connected.

**Unit operates in COOL mode even if it is set to HEAT mode.**



**Unit operates in HEAT mode even if it is set to COOL mode.**



### ① Check of outdoor fan motor

Disconnect the connectors CN931 and CN932 from the inverter P.C. board.  
Check the connection between the connector CN931 and CN932.

Is the resistance between each terminal of outdoor fan motor normal?  
(Refer to 10-4.)

Yes

Disconnect CN932 from the inverter P.C. board, and turn on the power supply.

Rotate the outdoor fan motor manually and measure the voltage of CN931.  
Between 1(+) and 5(-)  
Between 2(+) and 5(-)  
Between 3(+) and 5(-)

(Fixed to either 5 or 0 V DC)

No

Does the voltage between each terminal become 5 and 0 V DC repeatedly?

Yes

Does the outdoor fan motor rotate smoothly?

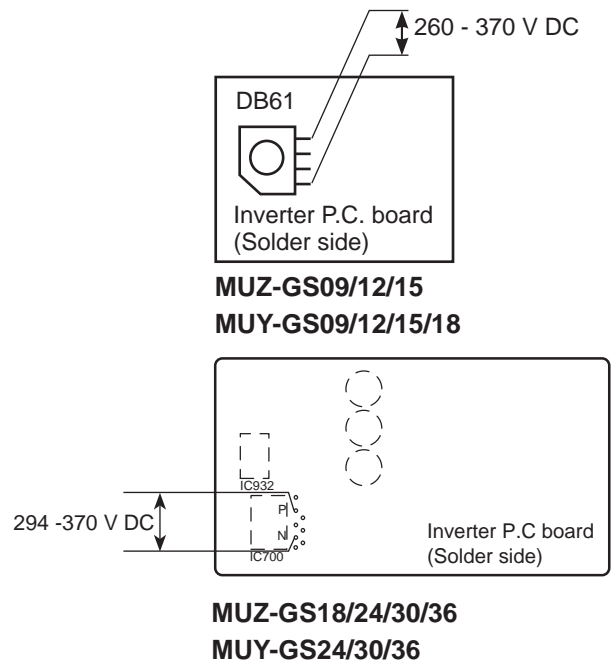
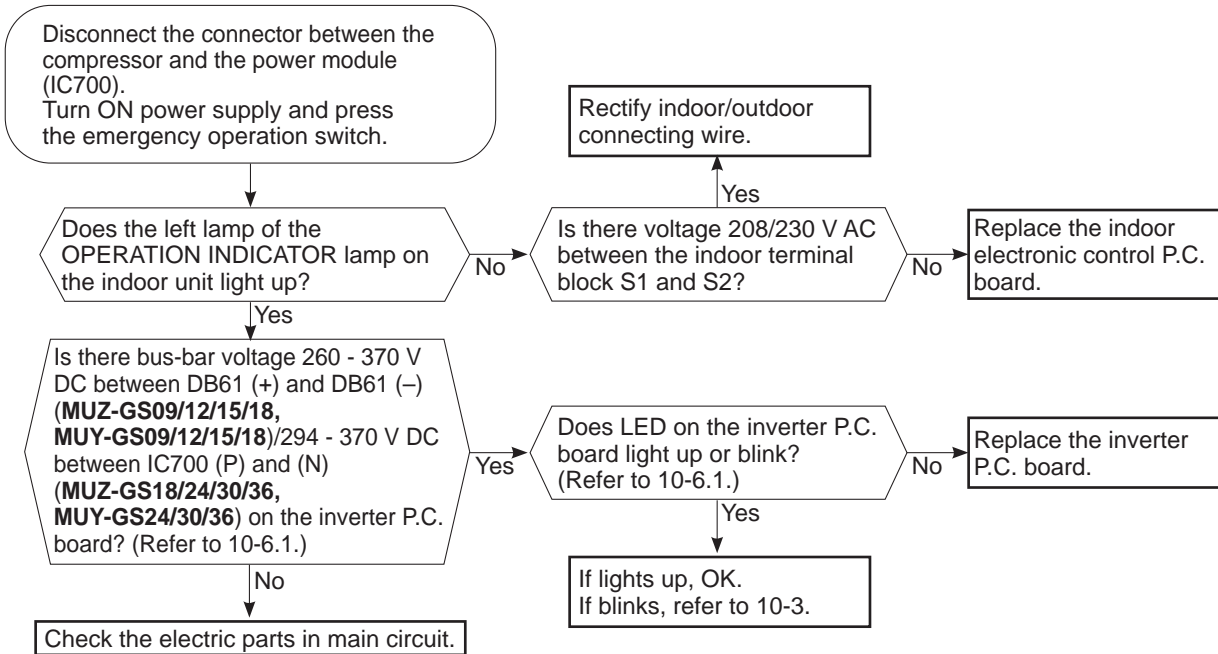
No

Yes

Replace the outdoor fan motor.

Replace the inverter P.C. board.

## Ⓜ Check of power supply

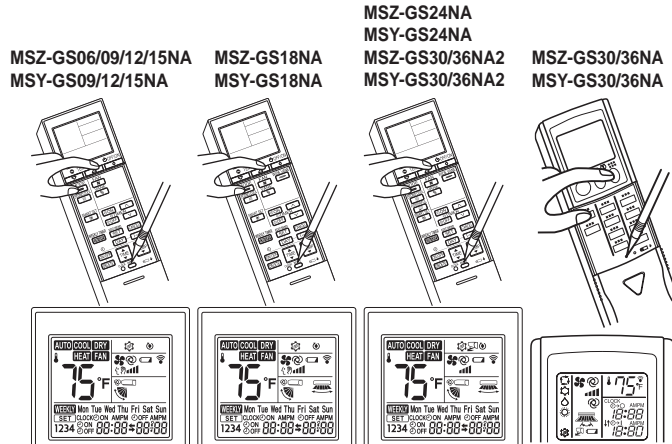


## Ⓚ Check of LEV (Expansion valve)

Turn ON the power supply.

<Preparation of the remote controller>

- ① While pressing both Operation select button and TEMP  $\oplus$  / TOO COOL button on the remote controller at the same time, press RESET button.
- ② First, release RESET button. Hold down the other 2 buttons for another 3 seconds. Make sure that the indicators on the LCD screen shown in the right figure are all displayed. Then release the buttons.



E.g.: MSZ type

Press OFF/ON (stop/operate) button of the remote controller (the set temperature is displayed) with the remote controller headed towards the indoor unit. \*1

Expansion valve operates in full-opening direction.

Do you hear the expansion valve “click, click……”?  
Do you feel the expansion valve vibrate when touching it?

Yes → OK

No

Is LEV coil properly fixed to the expansion valve?

No

Properly fix the LEV coil to the expansion valve.

Yes

Does the resistance of LEV coil have the characteristics? (Refer to 10-4.)

Yes

Measure each voltage between connector pins of CN724 on the inverter P.C. board.  
1. Pin③(-) — Pin①(+)  
2. Pin④(-) — Pin①(+)  
3. Pin⑤(-) — Pin①(+)  
4. Pin⑥(-) — Pin①(+)  
Is there about 3 - 5 V AC between each?  
**NOTE:** Measure the voltage by an analog multimeter.

No

Replace the inverter P.C. board.

No

Replace the LEV coil.

Yes

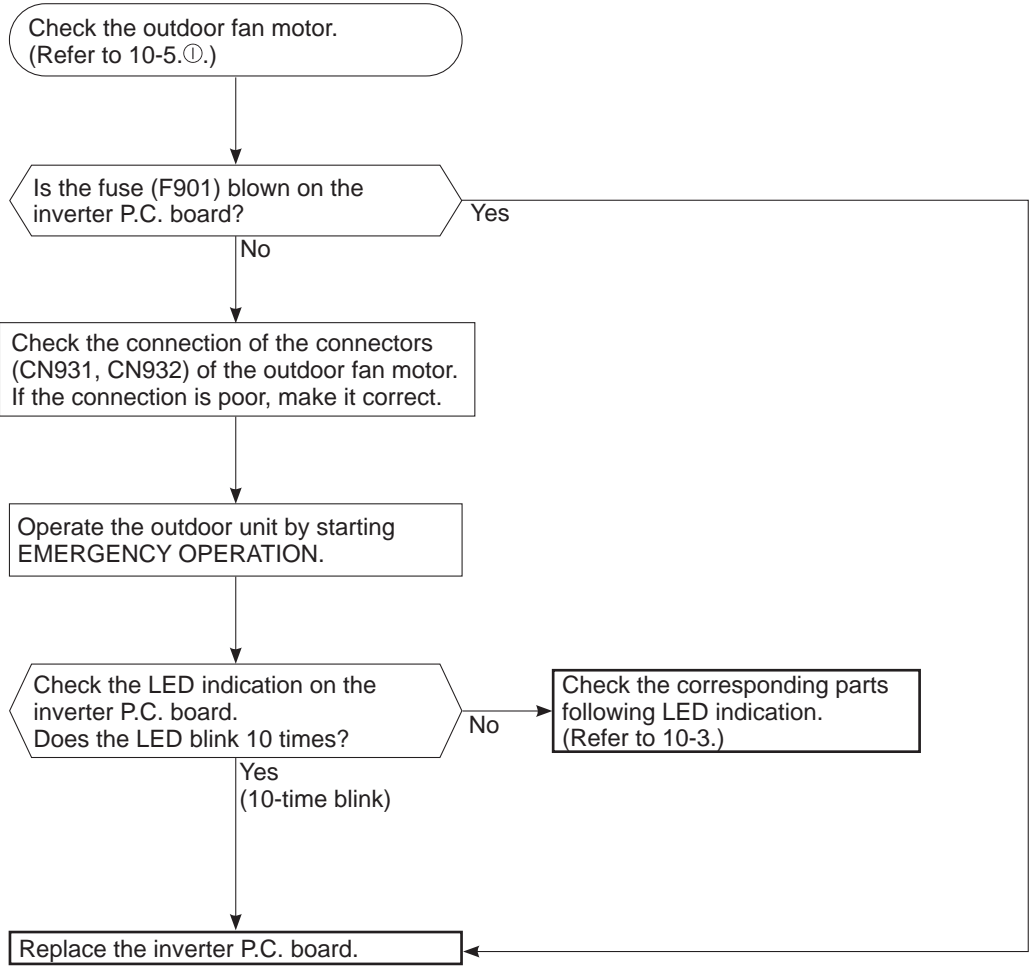
Replace the expansion valve.

\*1. Regardless of normal or abnormal condition, a short beep is emitted once the signal is received.

**NOTE:** After check of LEV, take the following steps.

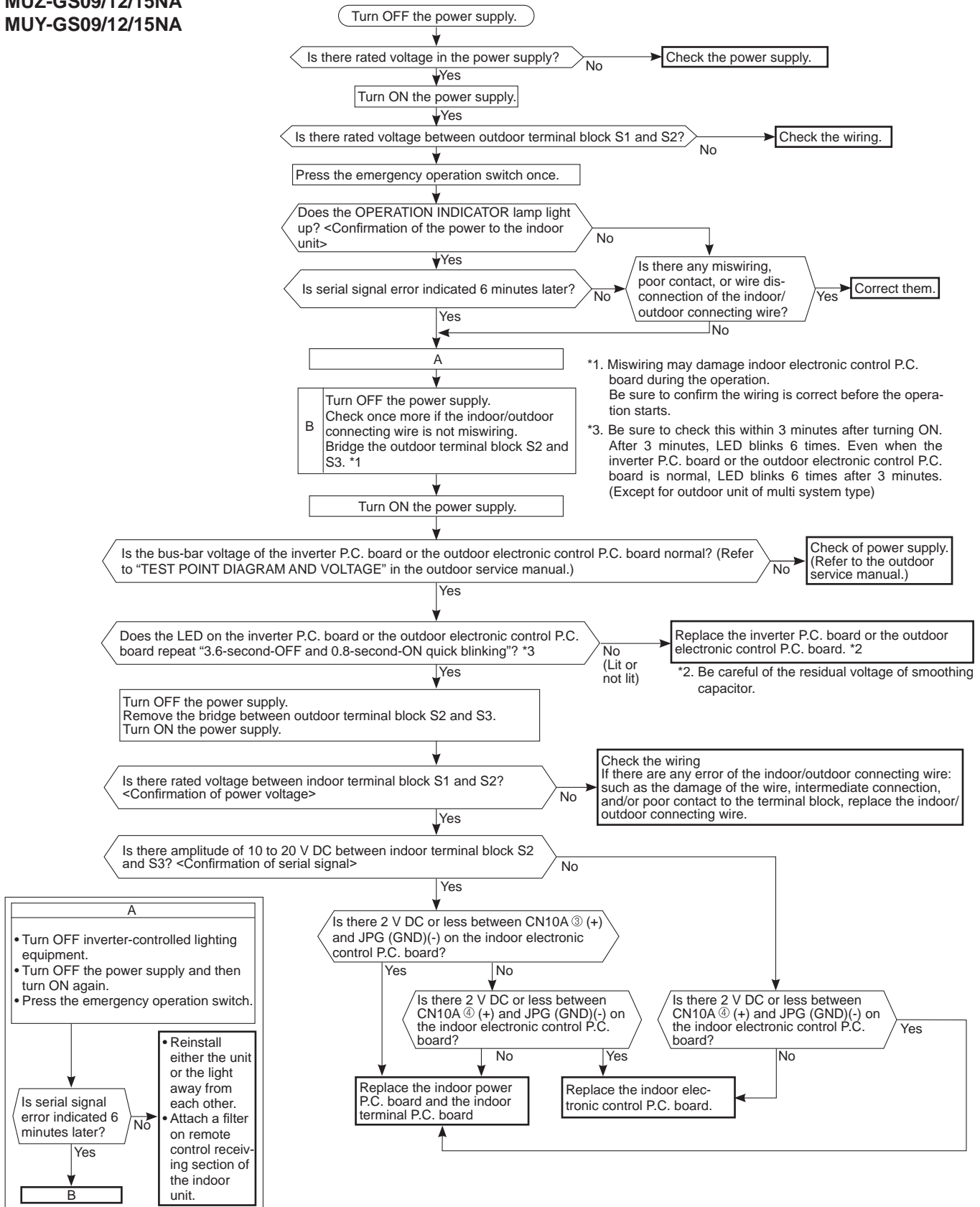
1. Turn OFF the power supply and turn it ON again.
2. Press RESET button on the remote controller.

**L Check of inverter P.C. board**



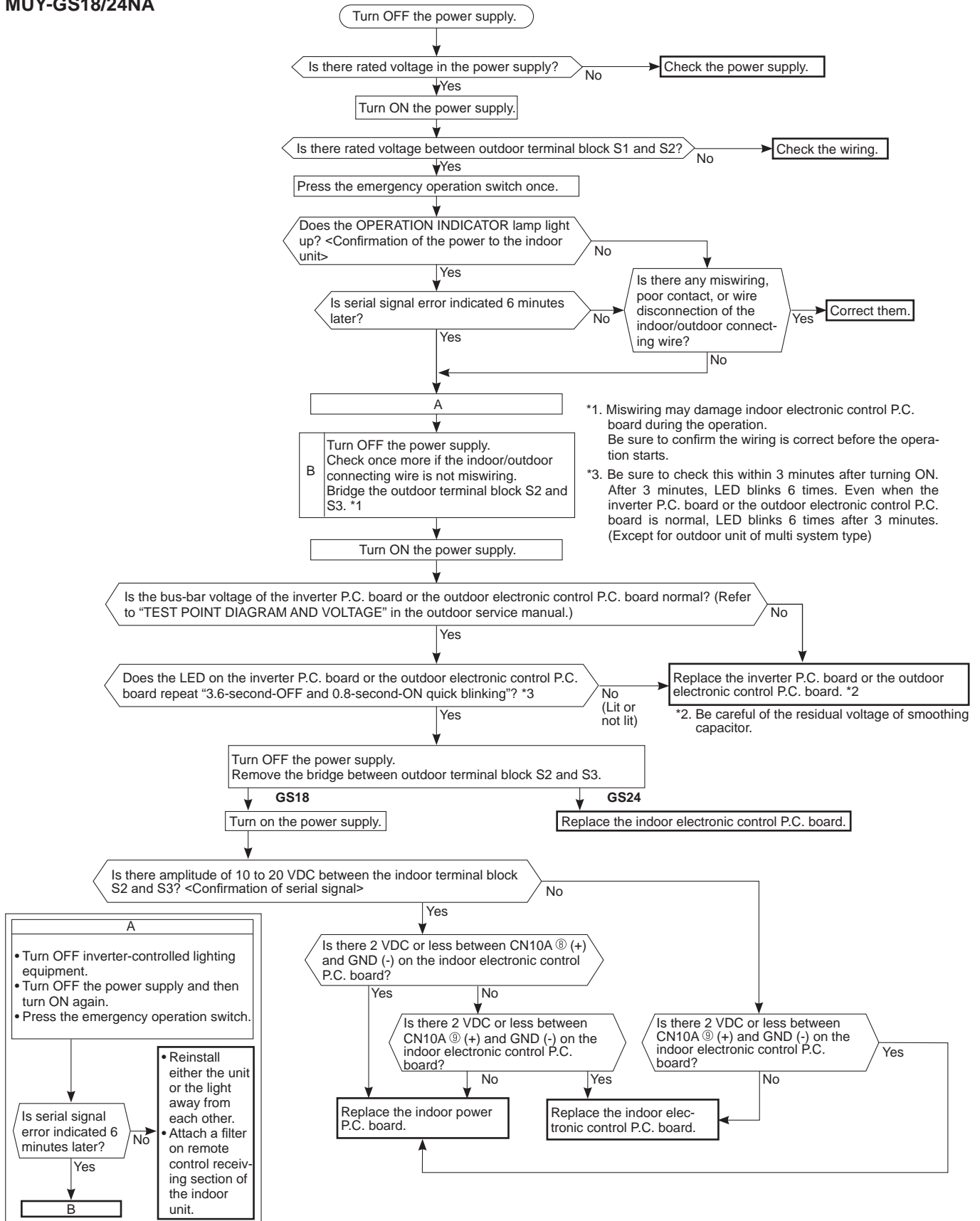
## M How to check miswiring and serial signal error

MUZ-GS09/12/15NA  
MUY-GS09/12/15NA

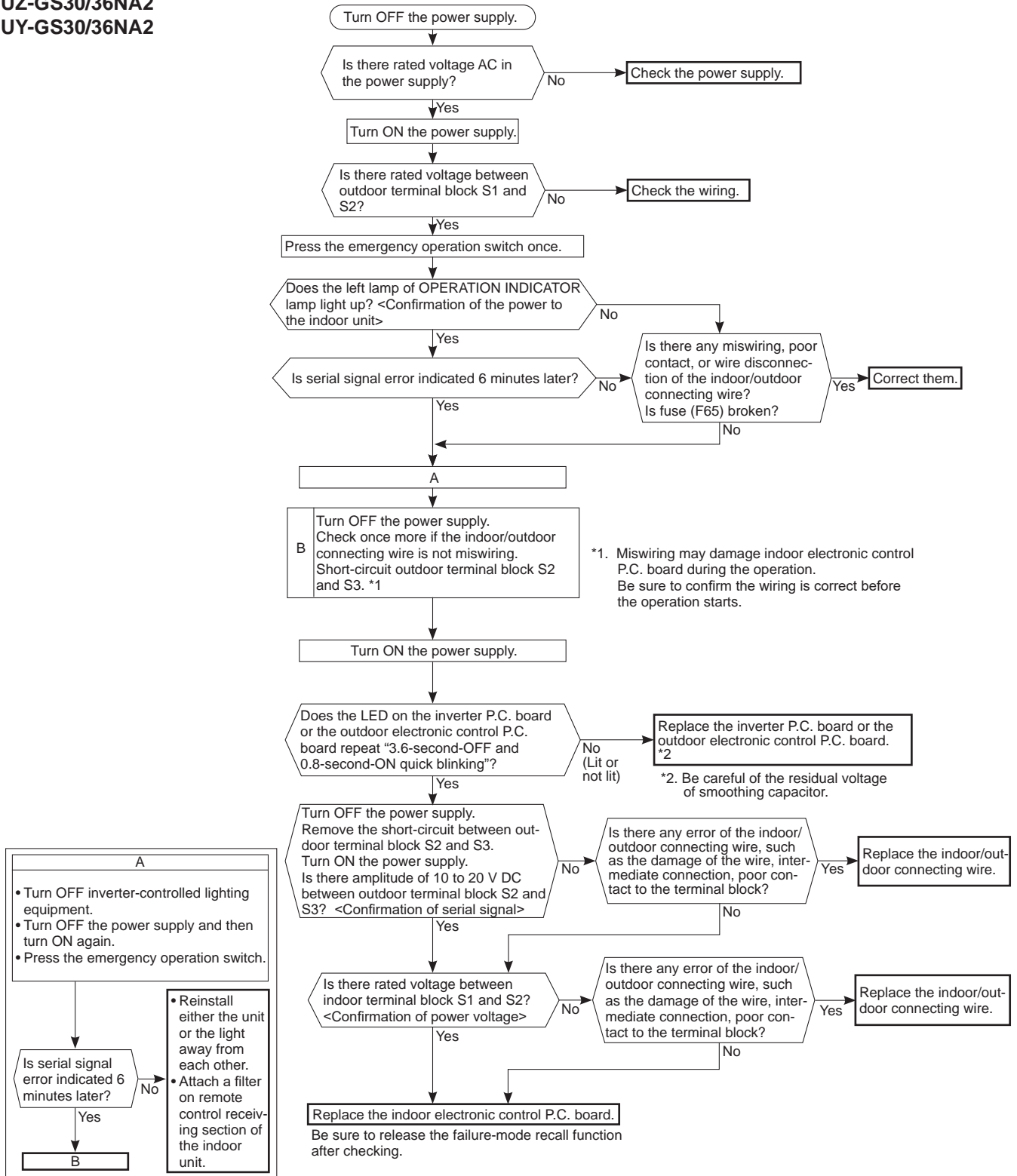


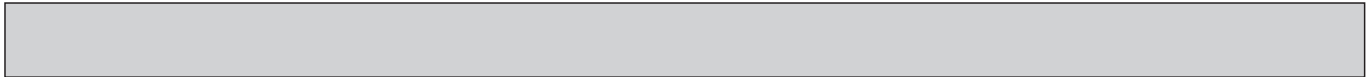


**MUZ-GS18/24NA**  
**MUY-GS18/24NA**



**MUZ-GS30/36NA**  
**MUY-GS30/36NA**  
**MUZ-GS30/36NA2**  
**MUY-GS30/36NA2**





**N Check of defrost heater**

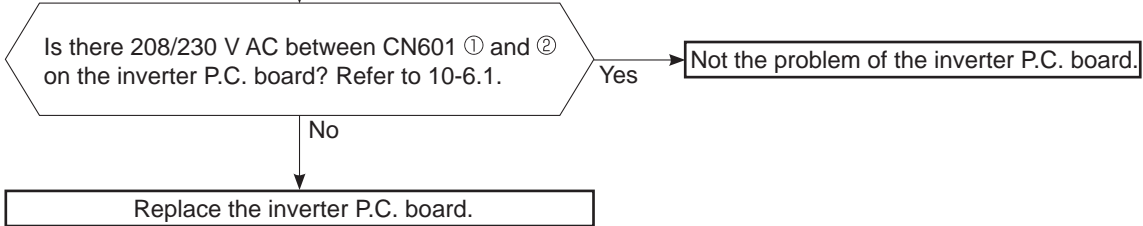
**MUZ-GS09NAH MUZ-GS09NAHZ MUZ-GS12NAH MUZ-GS12NAHZ  
MUZ-GS15NAH MUZ-GS15NAHZ MUZ-GS18NAH MUZ-GS18NAHZ  
MUZ-GS24NAH MUZ-GS24NAHZ MUZ-GS30NAH MUZ-GS30NAHZ  
MUZ-GS36NAH MUZ-GS36NAHZ**

Check the following points before checking electric continuity.

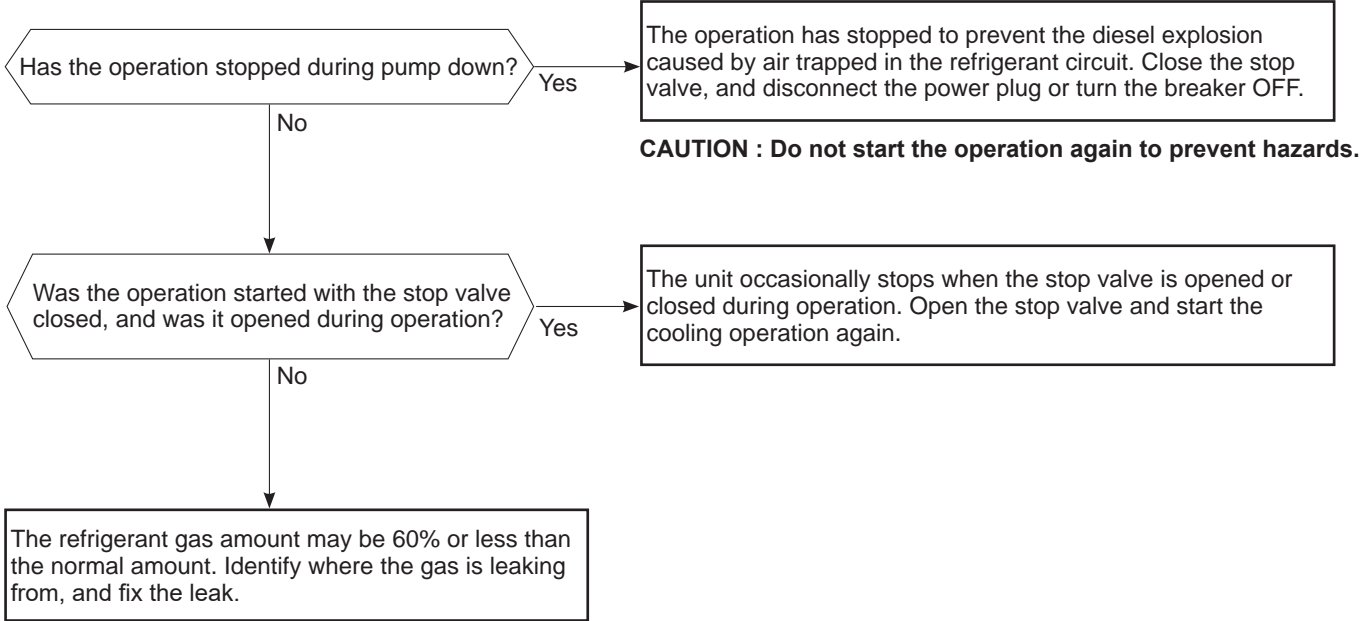
1. Does the resistance of ambient temperature thermistor have the characteristics? Refer to 10-6.1.
2. Is the resistance of defrost heater normal? Refer to 10-4.
3. Does the heater protector remain conducted (not open)?
4. Are both ambient temperature thermistor and circuit of defrost heater securely connected to connectors?

In HEAT mode, for more than 5 minutes, let the ambient temperature thermistor continue to read 32°F (0°C) or below, and let the defrost thermistor continue to read 30°F (-1°C) or below.

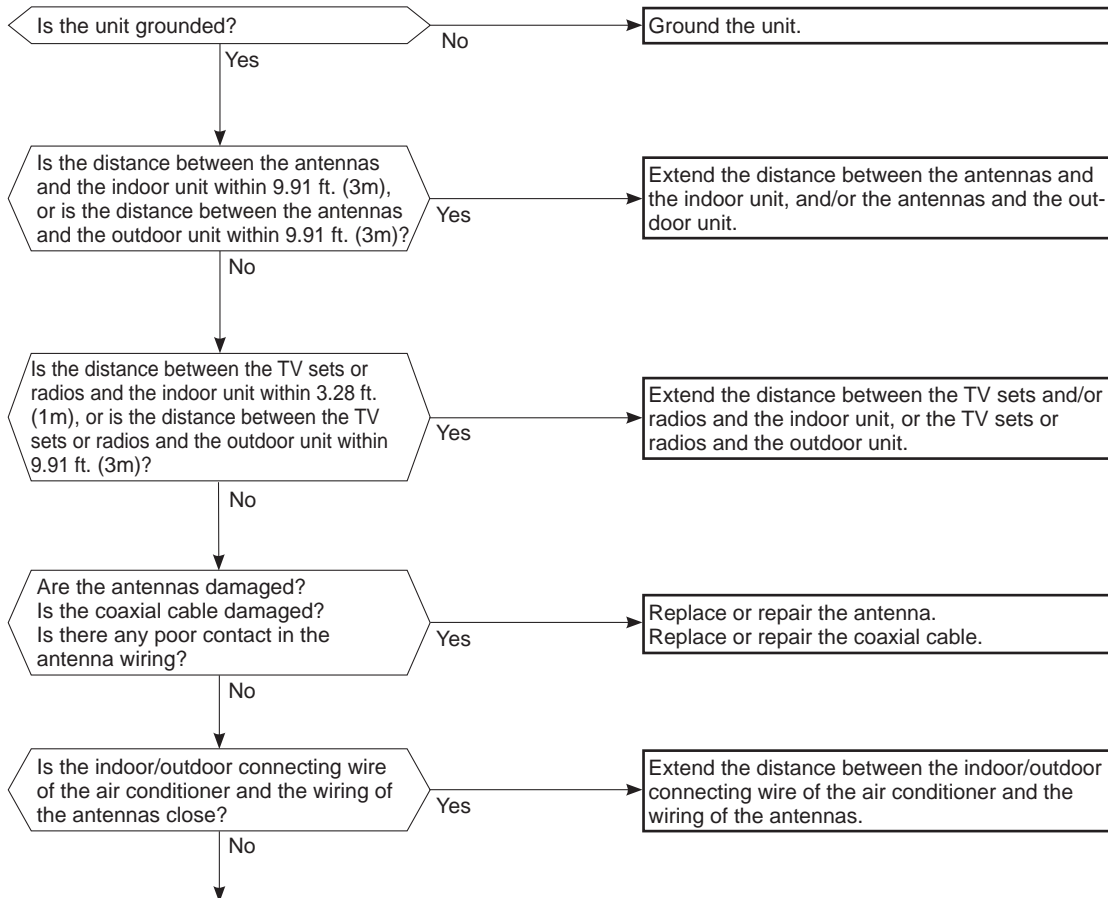
**NOTE:** In case both thermistors are more than the above temperature, cool them with cold water etc.



**O Check of outdoor refrigerant circuit**



**P Electromagnetic noise enters into TV sets or radios**

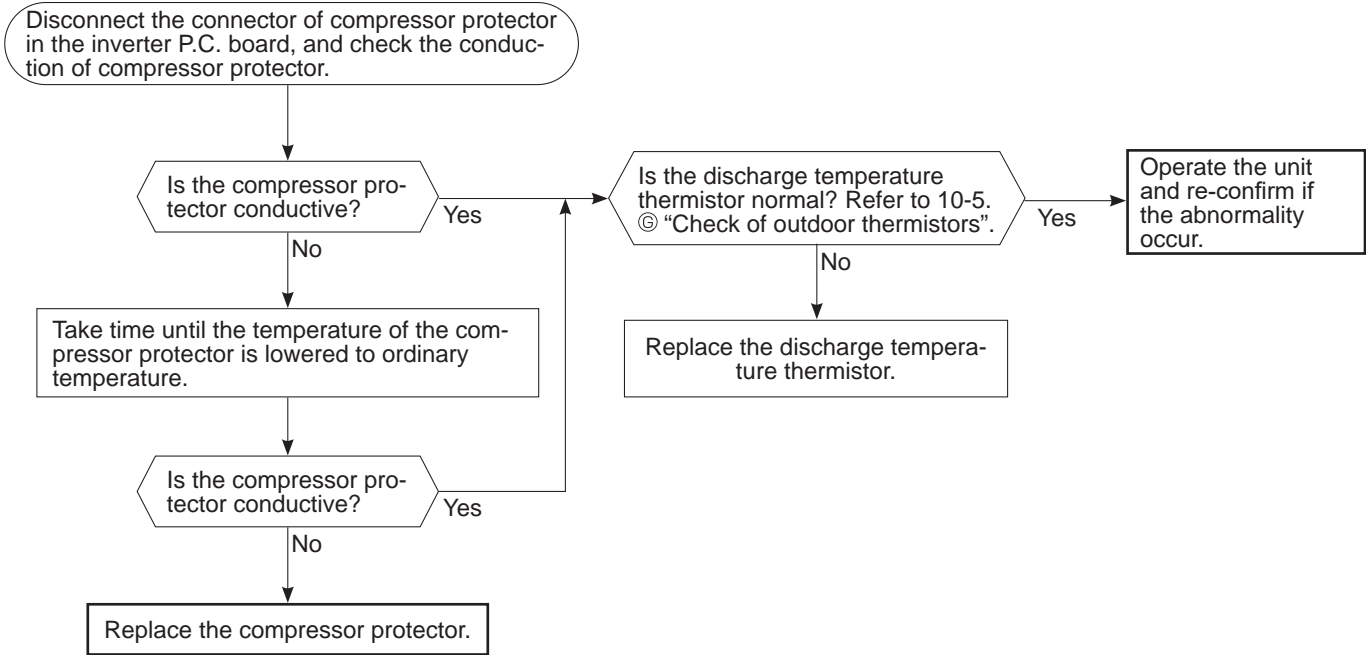


Even if all of the above conditions are fulfilled, the electromagnetic noise may enter, depending on the electric field strength or the installation condition (combination of specific conditions such as antennas or wiring). Check the following before asking for service.

1. Devices affected by the electromagnetic noise  
TV sets, radios (FM/AM broadcast, shortwave)
2. Channel, frequency, broadcast station affected by the electromagnetic noise
3. Channel, frequency, broadcast station unaffected by the electromagnetic noise
4. Layout of:  
indoor/outdoor unit of the air conditioner, indoor/outdoor wiring, ground wire, antennas, wiring from antennas, receiver
5. Electric field intensity of the broadcast station affected by the electromagnetic noise
6. Presence or absence of amplifier such as booster
7. Operation condition of air conditioner when the electromagnetic noise enters in
  - 1) Turn OFF the power supply once, and then turn ON the power supply. In this situation, check for the electromagnetic noise.
  - 2) Within 3 minutes after turning ON the power supply, press OFF/ON (stop/operate) button on the remote controller for power ON, and check for the electromagnetic noise.
  - 3) After a short time (3 minutes later after turning ON), the outdoor unit starts running. During operation, check for the electromagnetic noise.
  - 4) Press OFF/ON (stop/operate) button on the remote controller for power OFF, when the outdoor unit stops but the indoor/outdoor communication still runs on. In this situation, check for the electromagnetic noise.

**Q Check of compressor protector**

MUZ-GS09NA MUZ-GS09NAH MUZ-GS09NAHZ MUY-GS09NA  
 MUZ-GS12NA MUZ-GS12NAH MUZ-GS12NAHZ MUY-GS12NA  
 MUZ-GS15NA MUZ-GS15NAH MUZ-GS15NAHZ MUY-GS15NA  
 MUZ-GS18NA MUZ-GS18NAH MUZ-GS18NAHZ MUY-GS18NA  
 MUZ-GS24NA MUZ-GS24NAH MUZ-GS24NAHZ MUY-GS24NA  
 MUZ-GS30NA2 MUZ-GS30NAH2 MUY-GS30NA2  
 MUZ-GS36NA2 MUZ-GS36NAH2 MUY-GS36NA2

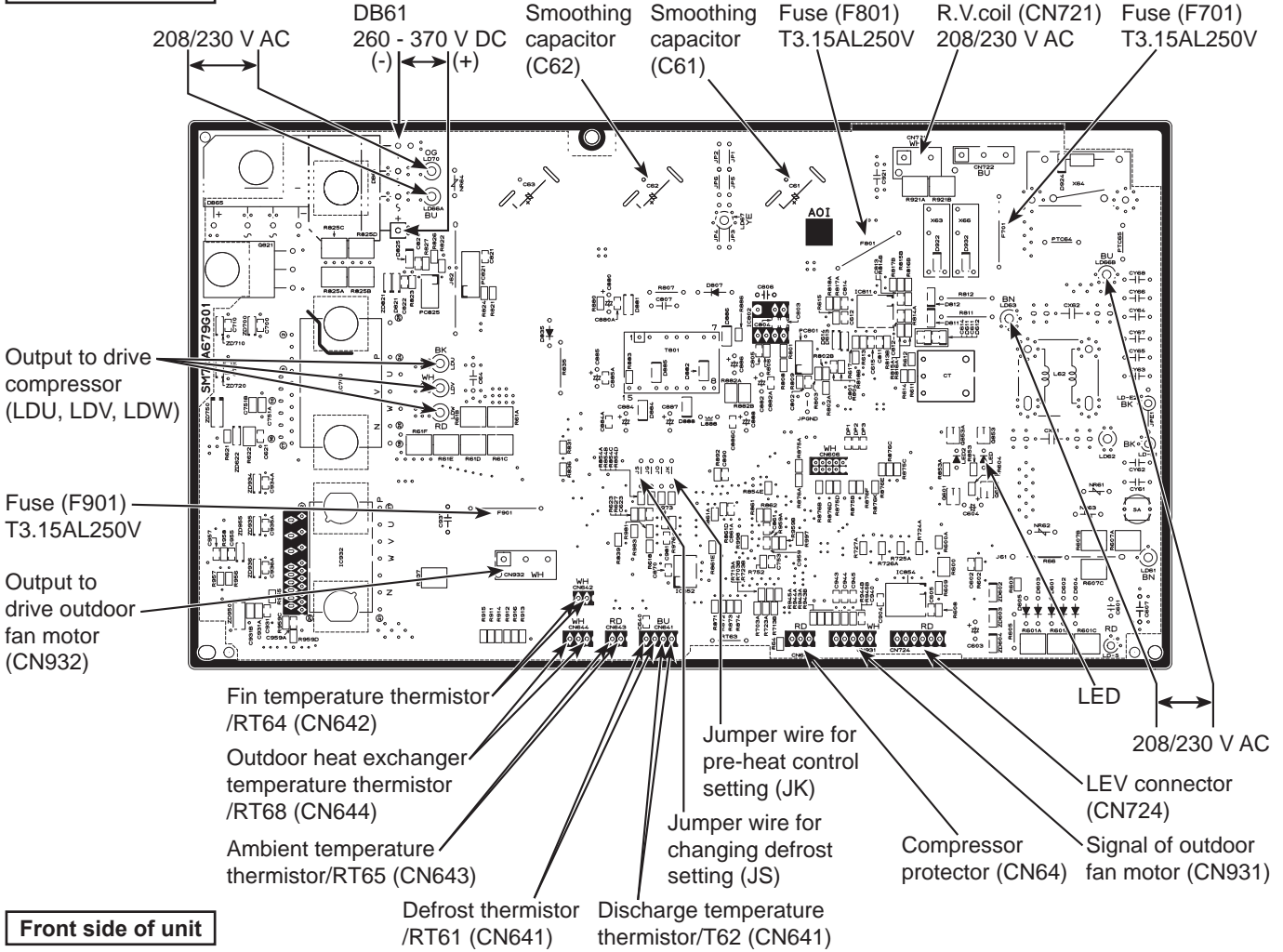


**10-6. TEST POINT DIAGRAM AND VOLTAGE**

**1. Inverter P.C. board**

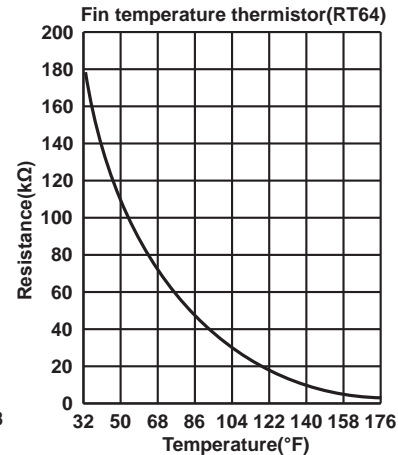
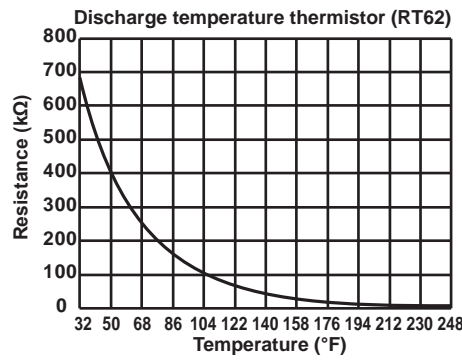
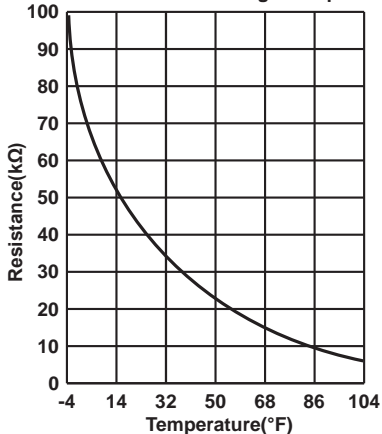
**MUZ-GS09NA MUZ-GS09NAH MUZ-GS09NAHZ MUY-GS09NA  
 MUZ-GS12NA MUZ-GS12NAH MUZ-GS12NAHZ MUY-GS12NA  
 MUZ-GS15NA MUZ-GS15NAH MUZ-GS15NAHZ MUY-GS15NA**

**Back side of unit**



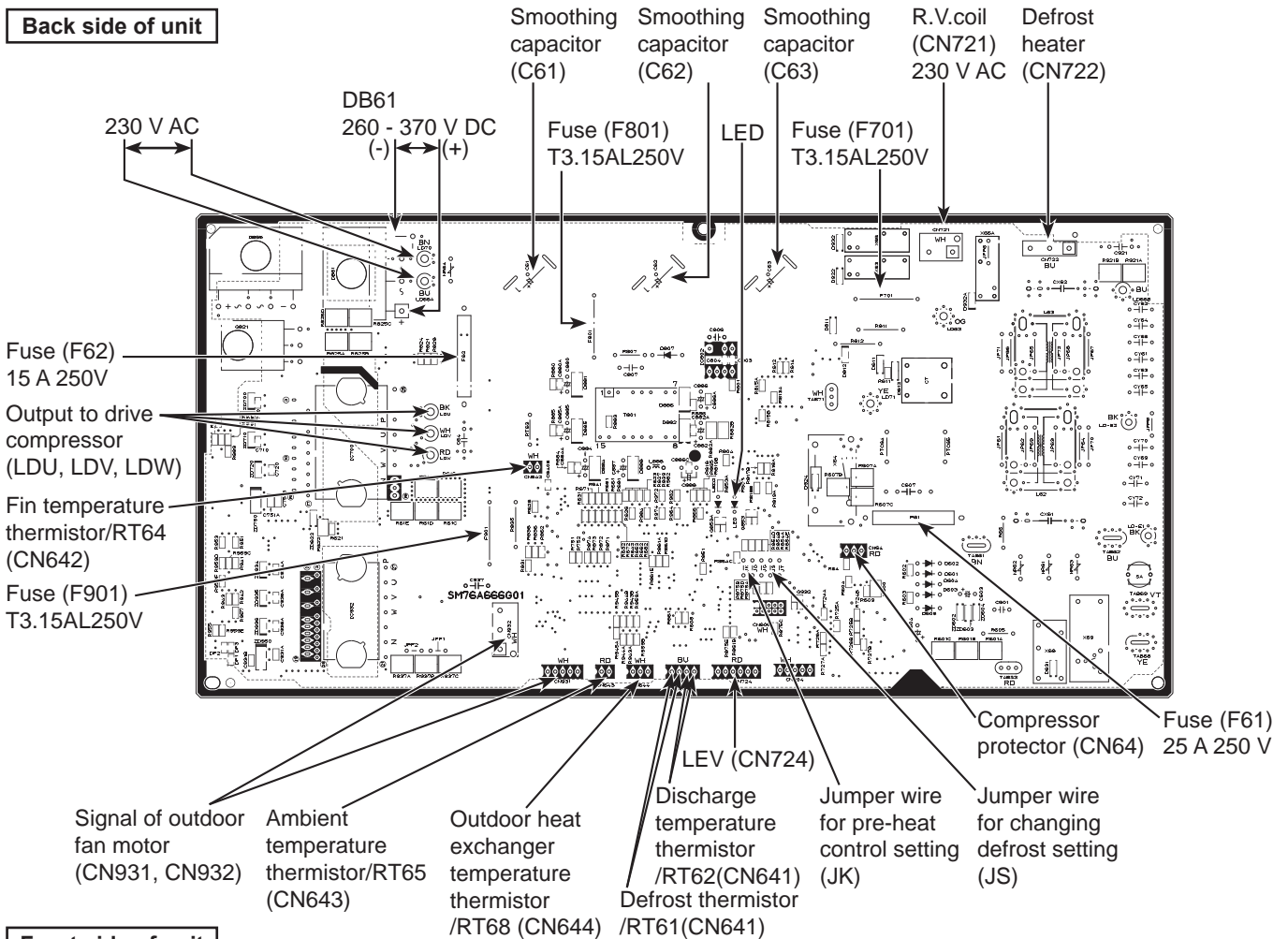
**Front side of unit**

**Defrost thermistor(RT61)  
 Ambient temperature thermistor(RT65)  
 Outdoor heat exchanger thermistor(RT68)**

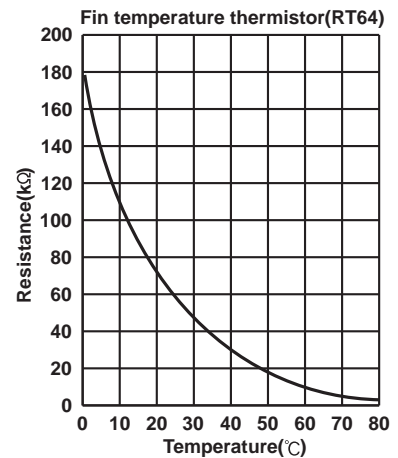
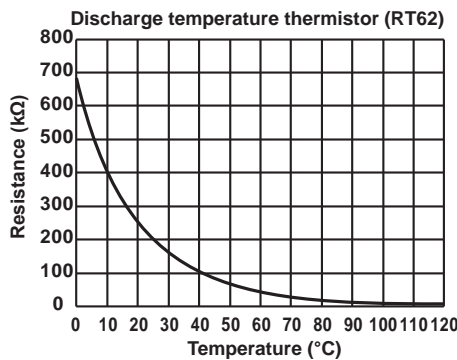
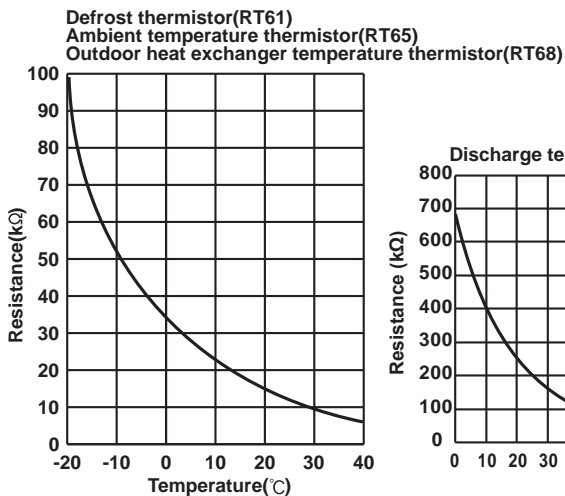


# MUZ-GS18NA MUZ-GS18NAH MUY-GS18NA

## Back side of unit

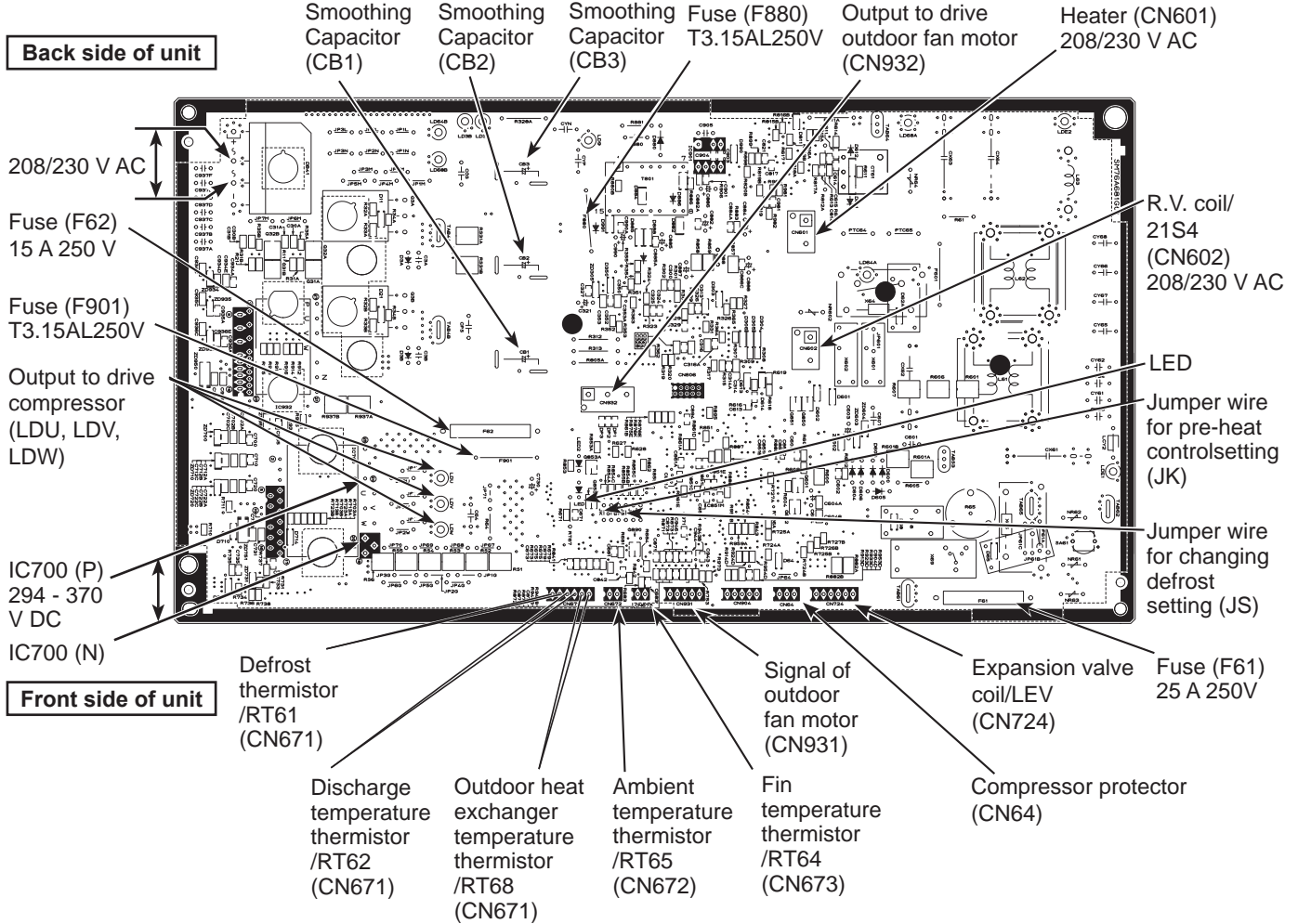


## Front side of unit

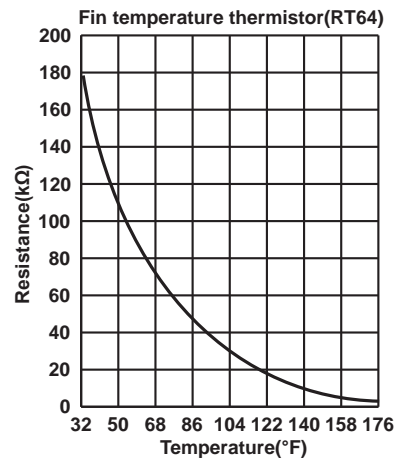
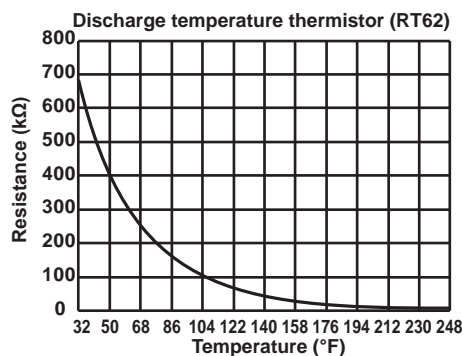
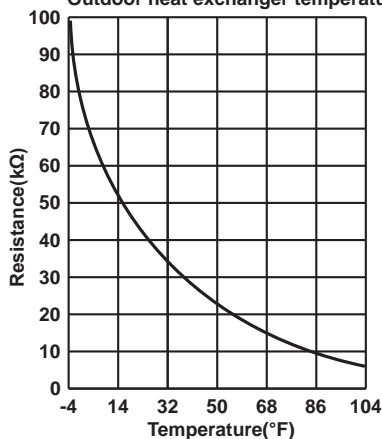




**MUZ-GS18NAHZ**  
**MUZ-GS24NA MUZ-GS24NAH MUZ-GS24NAHZ MUY-GS24NA**  
**MUZ-GS30NA MUZ-GS30NAH MUY-GS30NA**  
**MUZ-GS36NA MUZ-GS36NAH MUY-GS36NA**

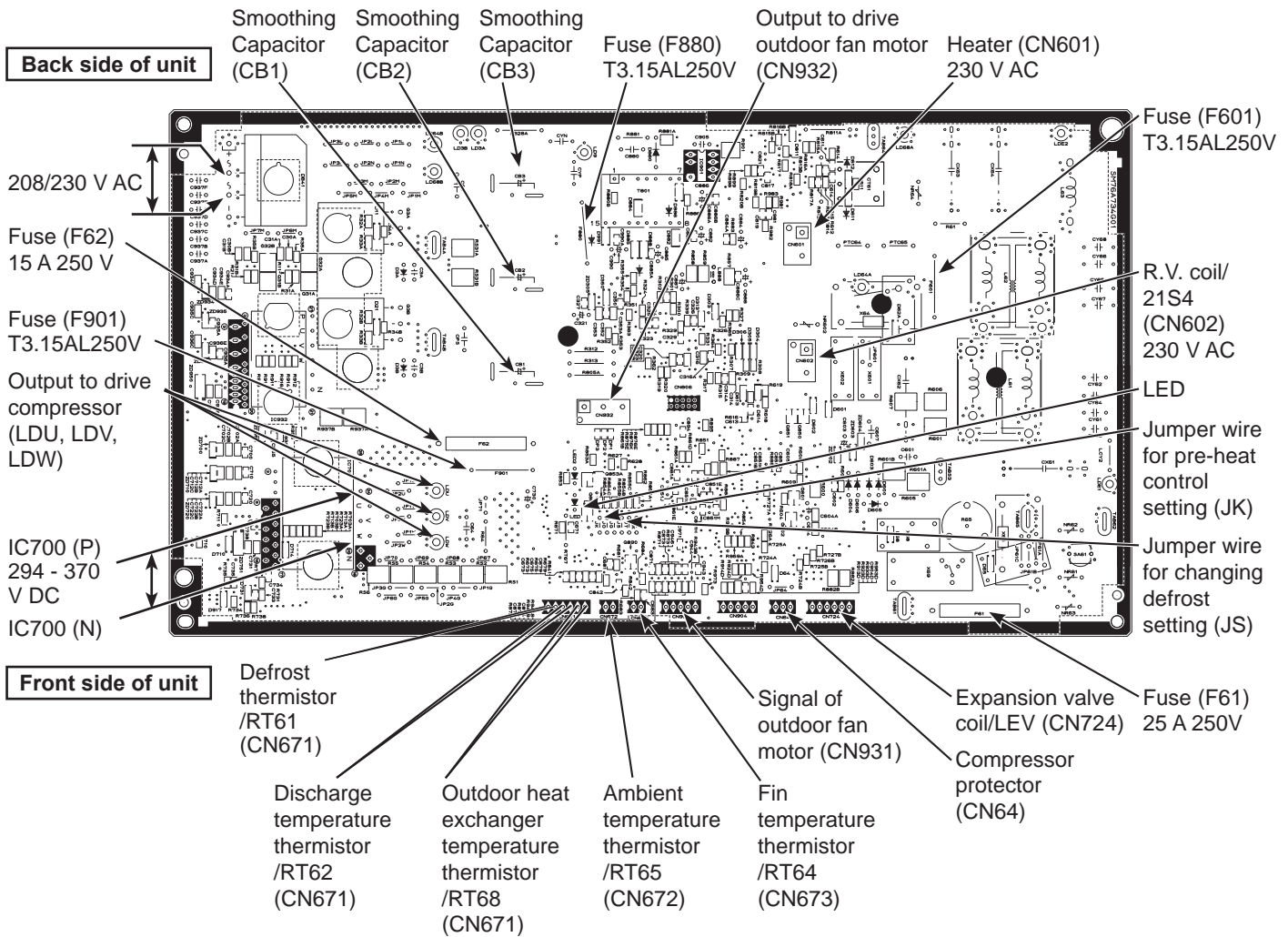


Defrost thermistor (RT61)  
 Ambient temperature thermistor (RT65)  
 Outdoor heat exchanger temperature thermistor (RT68)

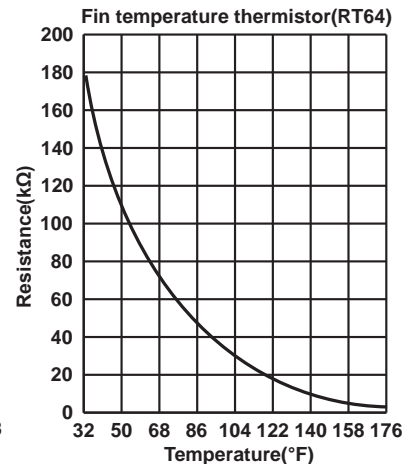
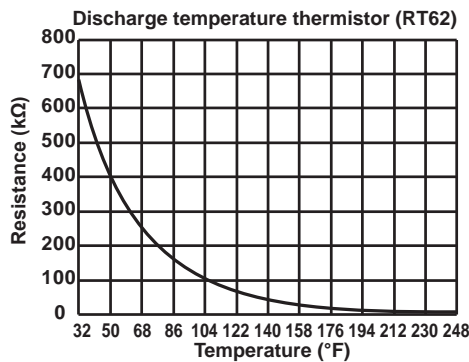
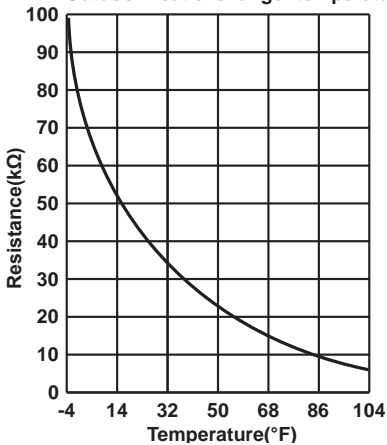




**MUZ-GS30NA2 MUZ-GS30NAH2 MUY-GS30NA2  
MUZ-GS36NA2 MUZ-GS36NAH2 MUY-GS36NA2**

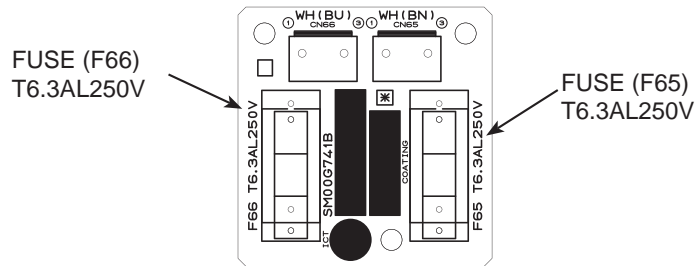


**Defrost thermistor(RT61)  
Ambient temperature thermistor(RT65)  
Outdoor heat exchanger temperature thermistor(RT68)**



2. Fuse P.C. board  
MUZ-GS18NAHZ

MUZ-GS24NA    MUZ-GS24NAHZ    MUY-GS24NA  
MUZ-GS30NA2    MUZ-GS30NAH2    MUY-GS30NA2  
MUZ-GS36NA2    MUZ-GS36NAH2    MUY-GS36NA2



<Detaching method of the terminal with locking mechanism>

The terminal which has the locking mechanism can be detached as shown below.

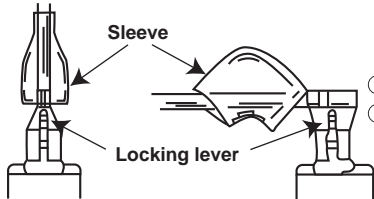
There are 2 types of the terminal with locking mechanism.

The terminal without locking mechanism can be detached by pulling it out.

Check the shape of the terminal before detaching.

(1) Slide the sleeve and check if there is a locking lever or not.

(2) The terminal with the connector shown below has the locking mechanism.



- ① Slide the sleeve.
- ② Pull the terminal while pushing the locking lever.



- ① Hold the sleeve, and pull out the terminal slowly.

- 11-1. MUZ-GS09NA MUZ-GS09NAH MUZ-GS09NAHZ MUY-GS09NA**  
**MUZ-GS12NA MUZ-GS12NAH MUZ-GS12NAHZ MUY-GS12NA**  
**MUZ-GS15NA MUZ-GS15NAH MUZ-GS15NAHZ MUY-GS15NA**

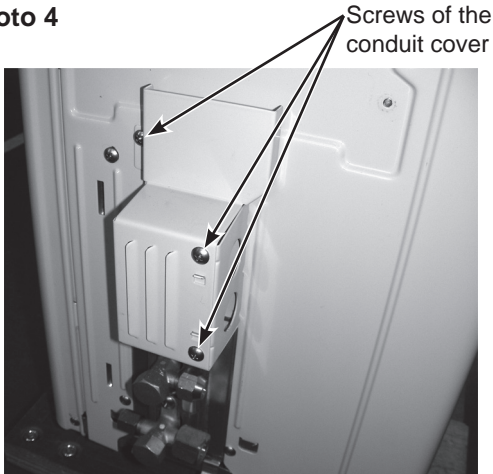
**NOTE:** Turn OFF the power supply before disassembly.

—————>: Indicates the visible parts in the photos/figures.  
 - - - - ->: Indicates the invisible parts in the photos/figures.

OPERATING PROCEDURE	PHOTOS/FIGURES
<p><b>1. Removing the cabinet</b></p> <p>(1) Remove the screw fixing the service panel.                      (2) Pull down the service panel and remove it.                      (3) Remove the screws fixing the conduit cover. (Photo 4)                      (4) Remove the conduit cover.                      (5) Remove the screw fixing the conduit plate. (Photo 5)                      (6) Remove the conduit plate.                      (7) Disconnect the power supply wire and indoor/outdoor connecting wire.                      (8) Remove the screws fixing the top panel.                      (9) Remove the top panel.                      (10) Remove the screws fixing the cabinet.                      (11) Remove the cabinet.                      (12) Remove the screws fixing the back panel.                      (13) Remove the back panel.</p> <p><b>Photo 2</b></p> <p>Screws of the top panel</p> <p>Screws of the cabinet</p>	<p><b>Photo 1</b></p> <p>Screws of the top panel</p> <p>Back panel</p> <p>Screws of the back panel</p> <p>Service panel</p> <p>Screws of the cabinet</p> <p><b>Photo 3</b></p> <p>Screw of the cabinet</p> <p>Screws of the terminal block support and the back panel</p> <p>Direction to remove</p> <p>Screws of the cabinet</p> <p>Hooks</p>

## OPERATING PROCEDURE

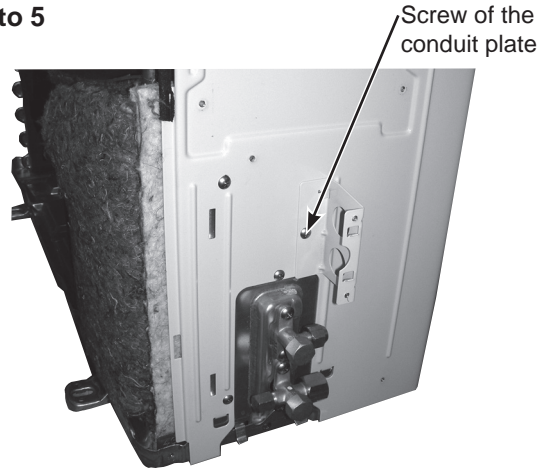
**Photo 4**



Screws of the conduit cover

## PHOTOS/FIGURES

**Photo 5**



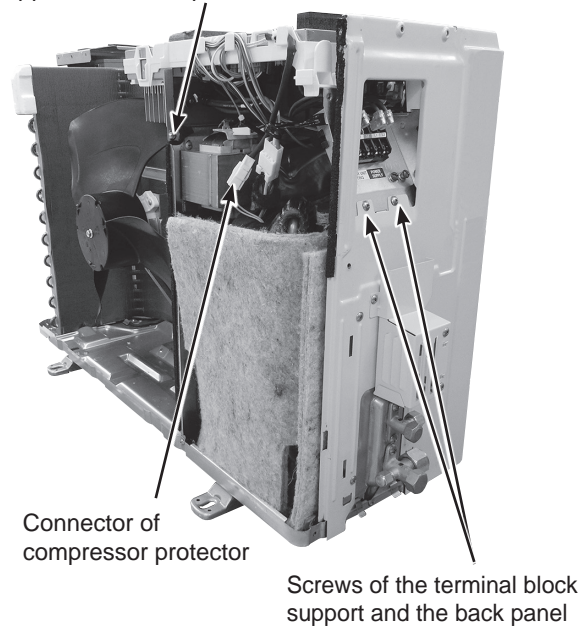
Screw of the conduit plate

### 2. Removing the inverter assembly, inverter P.C. board

- (1) Remove the top panel, cabinet and service panel. (Refer to section 1.)
- (2) Disconnect the lead wire to the reactor and the following connectors:
  - <Inverter P.C. board>
  - CN721 (R.V. coil) (**MUZ**)
  - CN722 (Defrost heater and heater protector) (**MUZ-GS09/12/15NAH, MUZ-GS09/12/15NAHZ**)
  - CN931, CN932 (Fan motor)
  - CN641 (Defrost thermistor (**MUZ**) and discharge temperature thermistor)
  - CN643 (Ambient temperature thermistor)
  - CN644 (Outdoor heat exchanger temperature thermistor)
  - CN724 (Expansion valve coil)
  - CN64 (Compressor protector)
- (3) Remove the compressor connector (CN61).
- (4) Remove the screws fixing the heat sink support and the separator.
- (5) Remove the fixing screws of the terminal block support and the back panel.
- (6) Remove the inverter assembly.
- (7) Remove the screw of the ground wire and screw of the terminal block support.
- (8) Remove the heat sink support from the P.C. board support.
- (9) Remove the screw of the inverter P.C. board and remove the inverter P.C. board from the P.C. board support.

**Photo 6**

Screw of the heat sink support and the separator



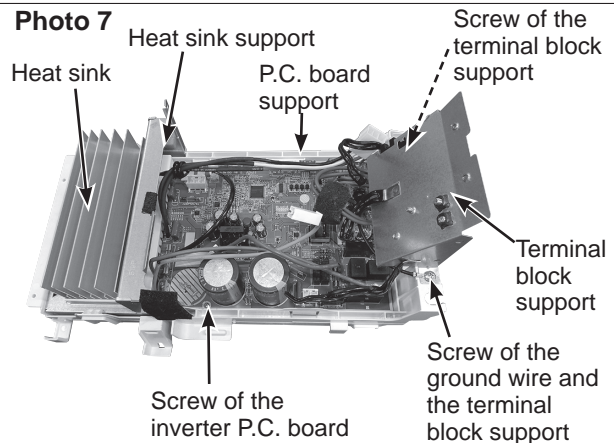
Connector of compressor protector

Screws of the terminal block support and the back panel

### 3. Removing R.V. coil

- (1) Remove the cabinet and panels. (Refer to section 1.)
- (2) Disconnect the following connectors:
  - <Inverter P.C. board>
  - CN721 (R.V. coil) (**MUZ**)
- (3) Remove the R.V. coil.

**Photo 7**



Heat sink

Heat sink support

P.C. board support

Screw of the terminal block support

Terminal block support

Screw of the inverter P.C. board

Screw of the ground wire and the terminal block support



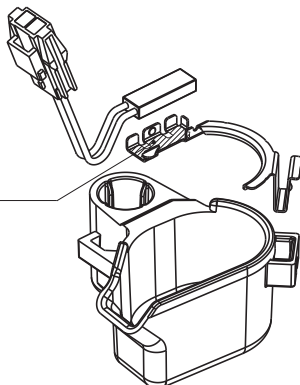
## OPERATING PROCEDURE

### 4. Removing the discharge temperature thermistor, defrost thermistor, outdoor heat exchanger temperature thermistor and ambient temperature thermistor

- (1) Remove the top panel, cabinet and service panel. (Refer to section 1.)
- (2) Disconnect the lead wire to the reactor and the following connectors:
  - <Inverter P.C. board>
  - CN641 (Defrost thermistor **(MUZ)** and discharge temperature thermistor)
  - CN643 (Ambient temperature thermistor)
  - CN644 (Outdoor heat exchanger temperature thermistor)
- (3) Pull out the discharge temperature thermistor from its holder.
- (4) Pull out the defrost thermistor from its holder.
- (5) Pull out the outdoor heat exchanger temperature thermistor from its holder.
- (6) Pull out the ambient temperature thermistor from its holder.

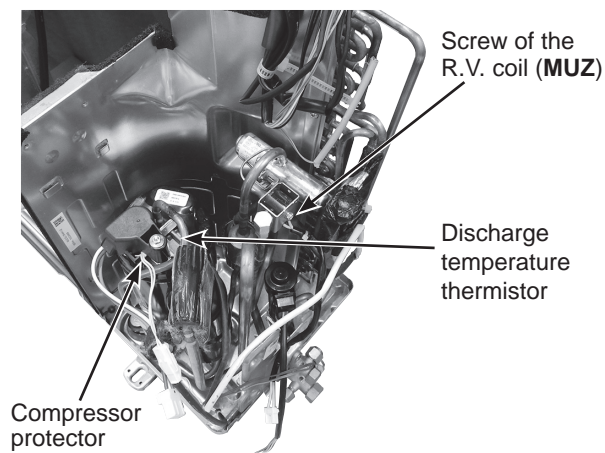
**Figure 1**

Attach the compressor protector to the protector holder with the surface on which the model name is printed facing the area hatched in the figure.



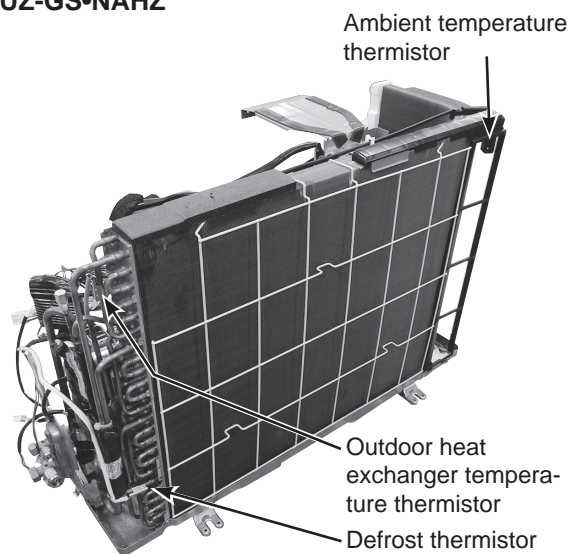
## PHOTOS/FIGURES

**Photo 8**

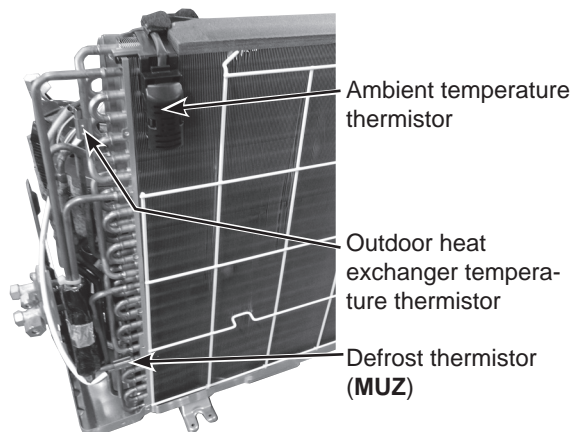


**Photo 9**

**MUZ-GS•NAHZ**



**Other models**



## OPERATING PROCEDURE

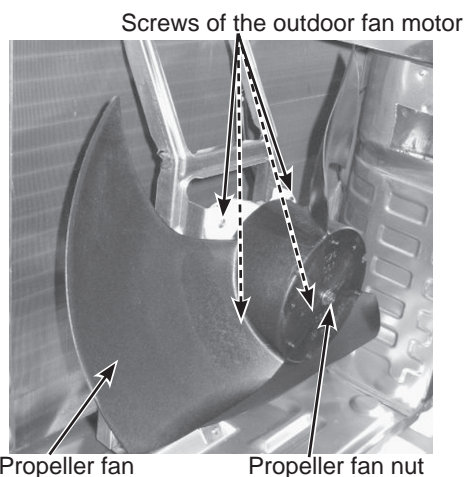
### 5. Removing outdoor fan motor

- (1) Remove the top panel, cabinet and service panel. (Refer to section 1.)
- (2) Disconnect the following connectors:  
<Inverter P.C. board>  
CN931, CN932 (Fan motor)
- (3) Remove the propeller fan nut.
- (4) Remove the propeller fan.
- (5) Remove the screws fixing the fan motor.
- (6) Remove the fan motor.

**NOTE:** The propeller fan nut is a reverse thread.

## PHOTOS/FIGURES

Photo 10



### 6. Removing the compressor and 4-way valve

- (1) Remove the cabinet and panels. (Refer to section 1.)
- (2) Remove the inverter assembly. (Refer to section 2.)
- (3) Remove the screws fixing the reactor.
- (4) Remove the reactor.
- (5) Remove the soundproof felt.
- (6) Recover gas from the refrigerant circuit.  
**NOTE:** Recover gas from the pipes until the pressure gauge shows 0 psig.
- (7) Detach the brazed part of the suction and the discharge pipe connected with compressor.
- (8) Remove the nuts fixing the compressor.
- (9) Remove the compressor.
- (10) Detach the brazed part of pipes connected with 4-way valve.

Photo 12

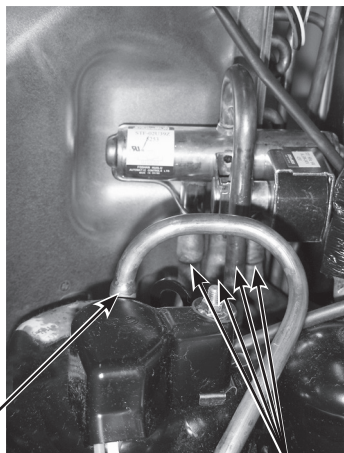
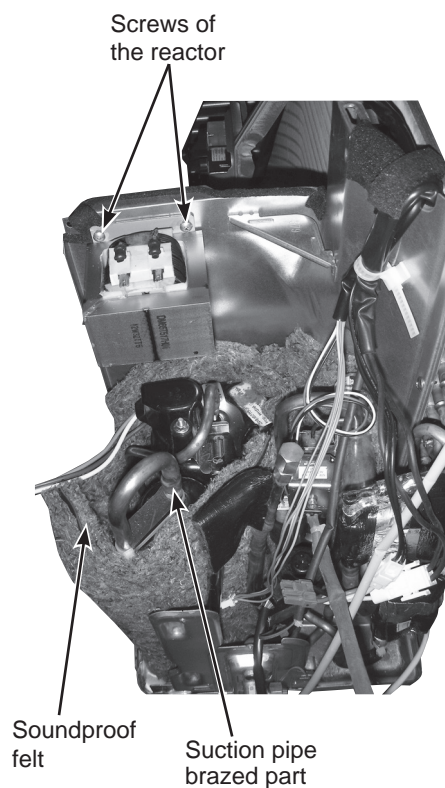
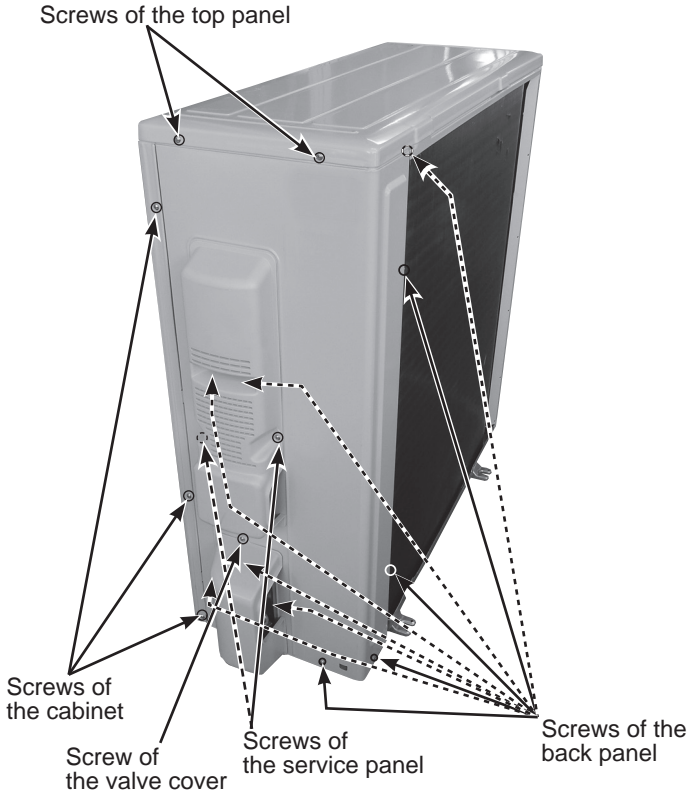
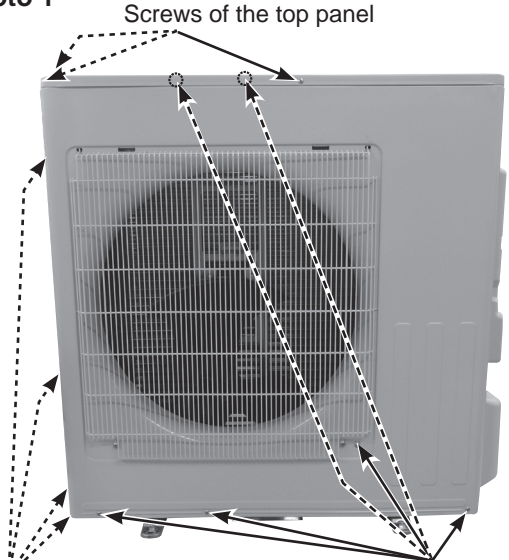

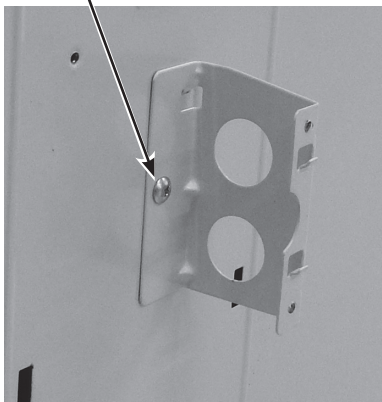


Photo 11



**11-2. MUZ-GS18NA MUZ-GS18NAH MUZ-GS18NAHZ MUY-GS18NA  
MUZ-GS24NA MUZ-GS24NAH MUZ-GS24NAHZ MUY-GS24NA**

**NOTE:** Turn OFF the power supply before disassembly.

OPERATING PROCEDURE	PHOTOS/FIGURES
<p><b>1. Removing the cabinet</b></p> <ol style="list-style-type: none"> <li>(1) Remove the screws of the service panel.</li> <li>(2) Remove the screws of the top panel.</li> <li>(3) Remove the screw of the valve cover.</li> <li>(4) Remove the service panel.</li> <li>(5) Remove the top panel.</li> <li>(6) Remove the valve cover.</li> <li>(7) Remove the screws fixing the conduit cover. (Photo 3)</li> <li>(8) Remove the conduit cover.</li> <li>(9) Remove the screw fixing the conduit plate. (Photo 4)</li> <li>(10) Remove the conduit plate.</li> <li>(11) Disconnect the power supply and indoor/outdoor connecting wire.</li> <li>(12) Remove the screws of the cabinet.</li> <li>(13) Remove the cabinet.</li> <li>(14) Remove the screws of the back panel.</li> <li>(15) Remove the back panel.</li> </ol> <p><b>Photo 2</b></p> 	<p><b>Photo 1</b></p>  <p><b>Photo 3</b></p>  <p><b>Photo 4</b></p> 



## OPERATING PROCEDURE

### 2. Removing the inverter assembly and inverter P.C. board (MUZ-GS18NA MUZ-GS18NAH MUY-GS18NA)

- (1) Remove the top panel, cabinet and service panel. (Refer to section 1.)
- (2) Disconnect the lead wire to the reactor and the following connectors:
  - <Inverter P.C. board>
  - CN602 (R.V. coil) (**MUZ**)
  - CN931, CN932 (Fan motor)
  - CN671 (Defrost thermistor (**MUZ**), discharge temperature thermistor and outdoor heat exchanger temperature thermistor)
  - CN672 (Ambient temperature thermistor)
  - CN724 (Expansion valve coil)
  - CN722 (Defrost heater and heater protector) (**MUZ-GS18NAH**)
  - CN64 (Compressor protector)
- (3) Remove the compressor connector (CN61).
- (4) Remove the screws fixing the heat sink support and the separator.
- (5) Remove the fixing screws of the terminal block support and the back panel.
- (6) Remove the inverter assembly.
- (7) Remove the heat sink support from the P.C. board support.
- (8) Remove the screws of the terminal block support, and the screws of the ground wires. (Photo 7)
- (9) Remove the terminal block support.
- (10) Remove the screw of the inverter P.C. board and remove the inverter P.C. board from the P.C. board support.

## PHOTOS/FIGURES

Photo 5

Screw of the heat sink support and the separator

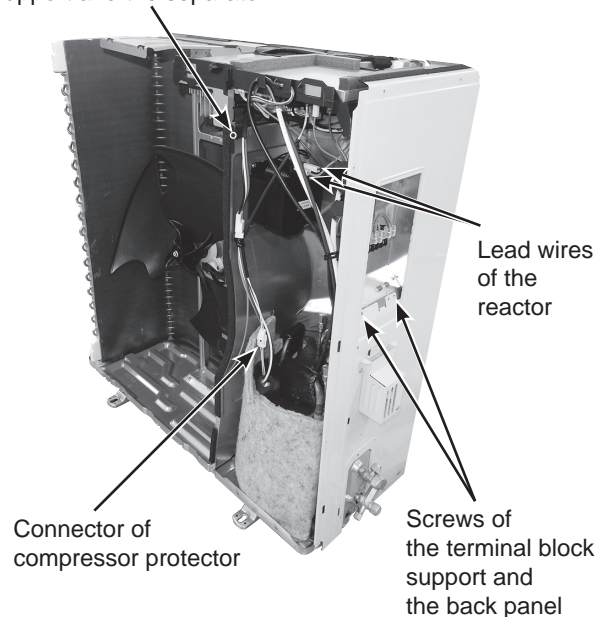
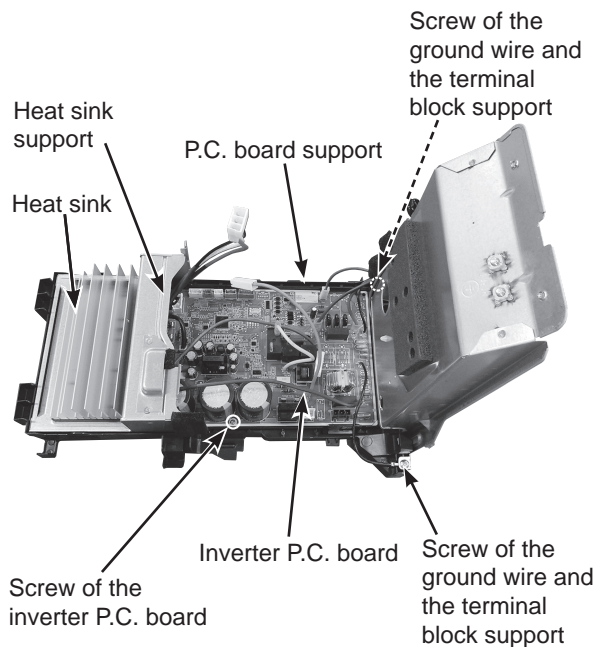


Photo 6 (Inverter assembly)





## OPERATING PROCEDURE

### \* Connection procedure when attaching the inverter P.C. board (Photo 8)

1. Attach the heat sink support to the P.C. board support.
2. Connect the lead wires of the expansion valve coil to the connector on the inverter P.C. board. Pull the lead wires of the expansion valve coil toward you and put them on the left hook on the P.C. board support as shown in Photo 8.

## PHOTOS/FIGURES

Photo 7

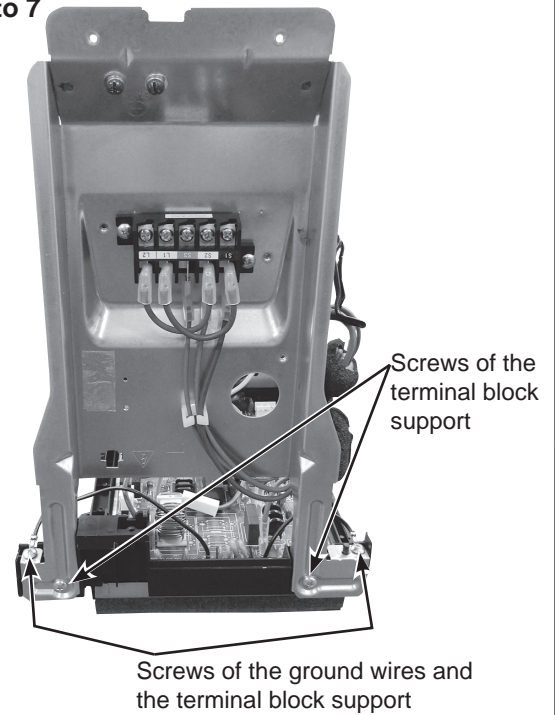
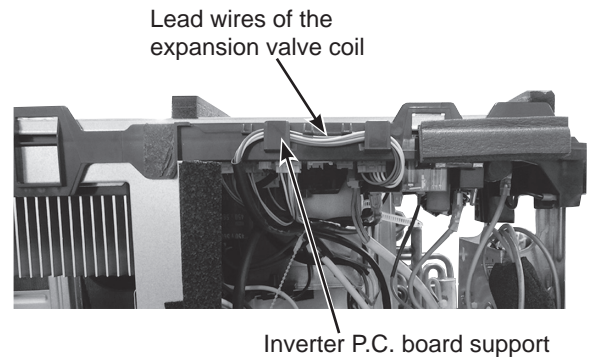


Photo 8



## OPERATING PROCEDURE

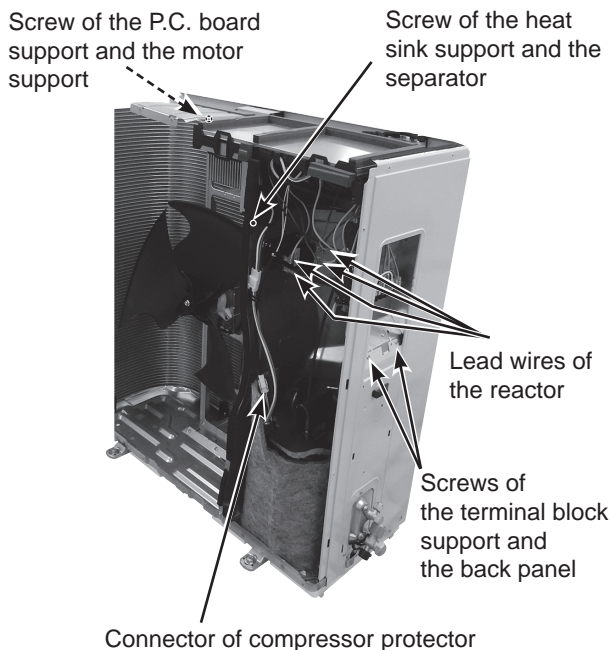
### 3. Removing the inverter assembly, inverter P.C. board and fuse P.C. board (Other models)

#### 3-1. Removing the inverter assembly and inverter P.C. board

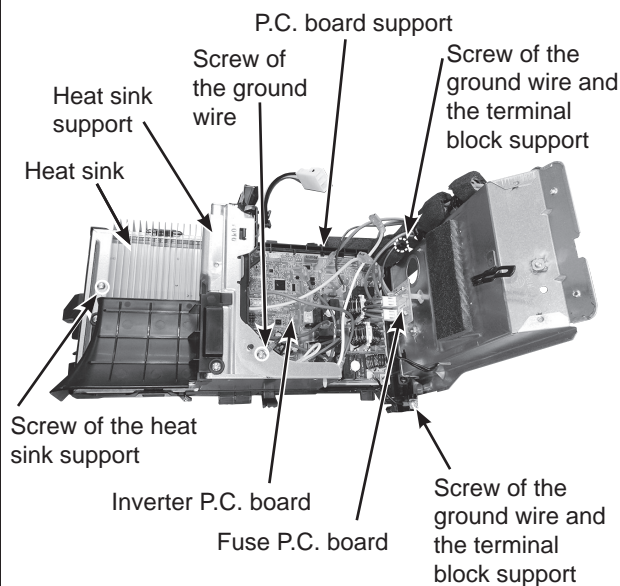
- (1) Remove the top panel, cabinet and service panel. (Refer to section 1.)
- (2) Disconnect the lead wire to the reactor and the following connectors:
  - <Inverter P.C. board>
  - CN602 (R.V. coil) (**MUZ**)
  - CN931, CN932 (Fan motor)
  - CN671 (Defrost thermistor (**MUZ**), discharge temperature thermistor and outdoor heat exchanger temperature thermistor)
  - CN672 (Ambient temperature thermistor)
  - CN724 (Expansion valve coil)
  - CN601 (Defrost heater and heater protector)
  - ( )
  - CN64 (Compressor protector)
- (3) Remove the compressor connector (CN61).
- (4) Remove the screws fixing the heat sink support and the separator.
- (5) Remove the screws fixing the P.C. board support and the motor support.
- (6) Remove the fixing screws of the terminal block support and the back panel.
- (7) Remove the inverter assembly.
- (8) Remove the screws of the ground wires and the terminal block support.
- (9) Remove the screw of the heat sink support, and the heat sink support from the P.C. board support.

## PHOTOS/FIGURES

**Photo 9**



**Photo 10 (Inverter assembly)**



## OPERATING PROCEDURE

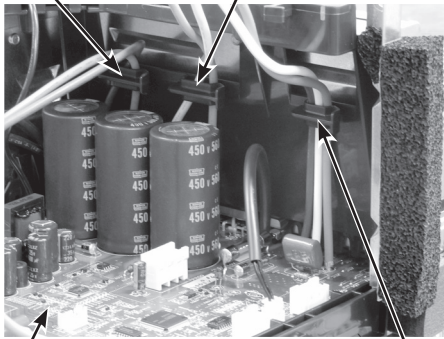
### \* Connection procedure when attaching the inverter P.C. board (Photo 12,13)

1. Attach the heat sink support to the P.C. board support.
2. Hook the lead wires of the compressor, the reactor and the P.C. board to each hooks on the heat sink support as shown Photo 12.
3. Connect the lead wires of the expansion valve coil to the connector on the inverter P.C. board. Pull the lead wires of the expansion valve coil toward you and put them on the left hook on the P.C. board support as shown in Photo 13.
4. Tighten the lead wires of the fan motor (CN931), defrost thermistor, discharge temperature thermistor, outdoor heat exchanger temperature thermistor, ambient temperature thermistor and LEV with the fastener as shown in Photo 13.

**Photo 12**

Hook of the lead wires of the P.C. board

Hook of the lead wires of the reactor

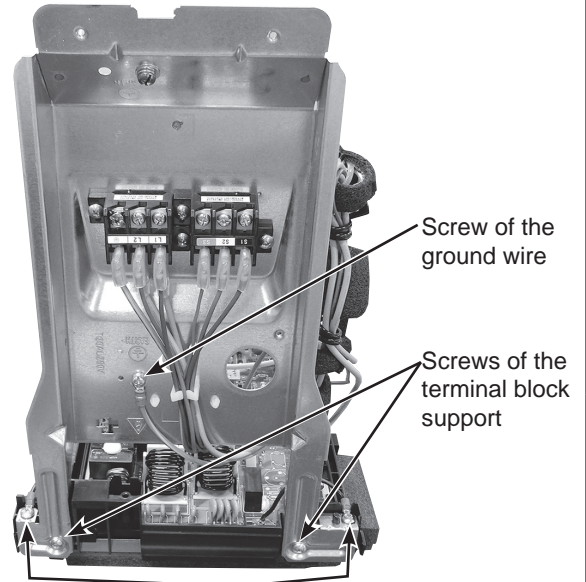


Inverter P.C. board

Hook of the lead wires of the compressor

## PHOTOS/FIGURES

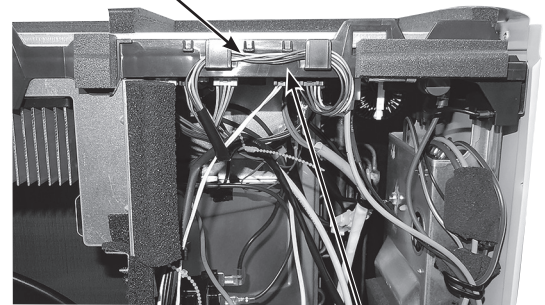
**Photo 11**



Screws of the ground wires and the terminal block support

**Photo 13**

Lead wires of the expansion valve coil



Inverter P.C. board support

## OPERATING PROCEDURE

### 3-2. Removing the fuse P.C. board

- (1) Remove the top panel, cabinet and service panel. (Refer to section 1.)
- (2) Disconnect the lead wire to the reactor and the inverter P.C. board connectors. (Refer to section 3-1. (2))
- (3) Remove the compressor connector (CN61).
- (4) Remove the screws fixing the heat sink support and the separator.
- (5) Remove the screws fixing the P.C. board support and the motor support.
- (6) Remove the fixing screws of the terminal block support and the back panel.
- (7) Remove the inverter assembly.
- (8) Remove the following disconnected connectors:  
<Fuse P.C. board>  
CN65, CN66 (Terminal block)
- (9) Remove the fuse P.C. board from the supports. (Photo 15)

## PHOTOS/FIGURES

Photo 14

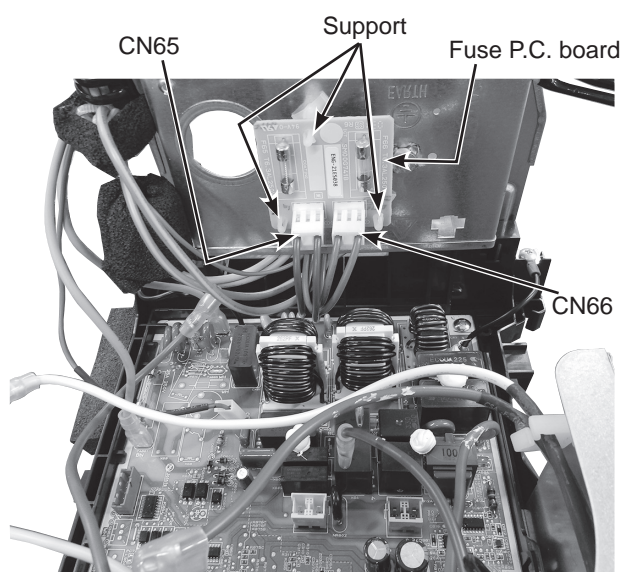
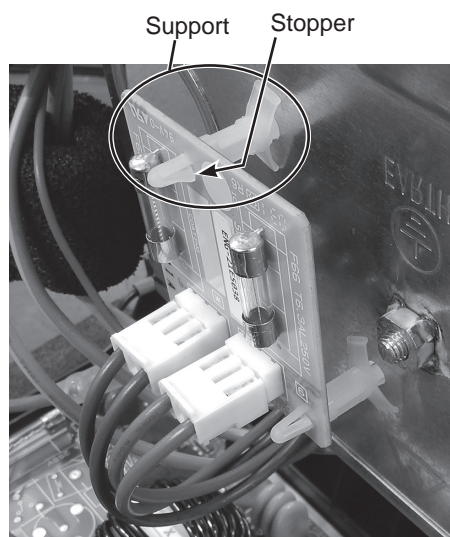
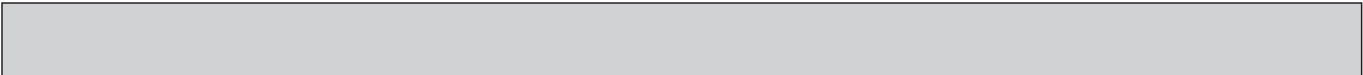


Photo 15



Pinch the stopper of the support, and push it into the hole to remove the fuse P.C. board.





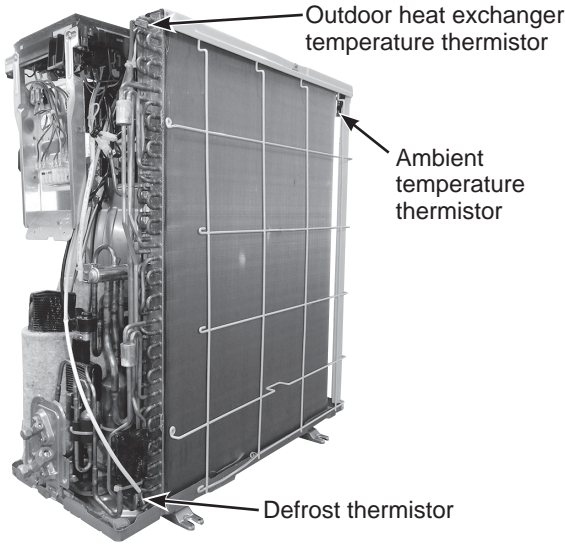
**OPERATING PROCEDURE**

**4. Removing the discharge temperature thermistor, defrost thermistor, outdoor heat exchanger temperature thermistor and ambient temperature thermistor**

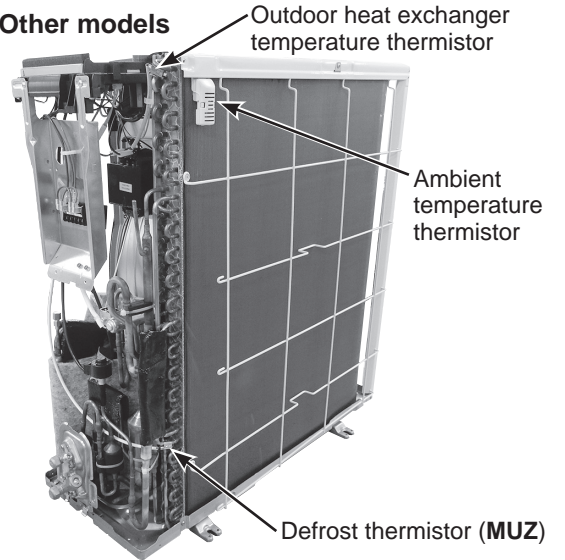
- (1) Remove the cabinet and panels. (Refer to section 1.)
- (2) Disconnect the lead wire to the reactor and the following connectors:  
<Inverter P.C. board>  
CN671 (Defrost thermistor (**MUZ**), discharge temperature thermistor and outdoor heat exchanger temperature thermistor)  
CN672 (Ambient temperature thermistor)
- (3) Pull out the discharge temperature thermistor from its holder. (Photo 18)
- (4) Pull out the defrost thermistor from its holder.
- (5) Pull out the outdoor heat exchanger temperature thermistor from its holder. (Photo 16)
- (6) Pull out the ambient temperature thermistor from its holder.

**PHOTOS/FIGURES**

**Photo 16  
MUZ-GS•NAHZ**



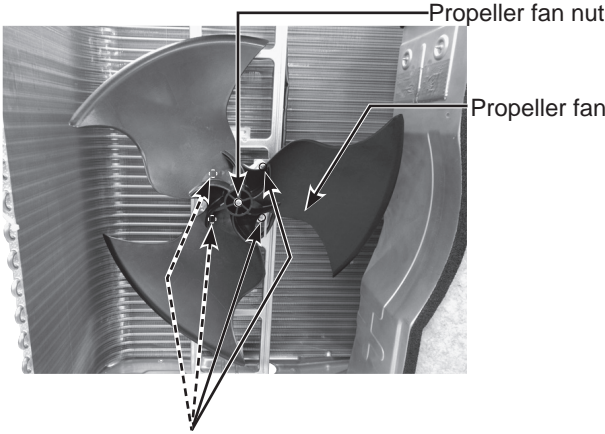
**Other models**



**5. Removing outdoor fan motor**

- (1) Remove the top panel, cabinet and service panel. (Refer to section 1.)
- (2) Disconnect the following connectors:  
<Inverter P.C. board>  
CN931, CN932 (Fan motor)
- (3) Remove the propeller fan nut.
- (4) Remove the propeller fan.
- (5) Remove the screws fixing the fan motor.
- (6) Remove the fan motor.

**Photo 17**



## OPERATING PROCEDURE

### 6. Removing the compressor and 4-way valve

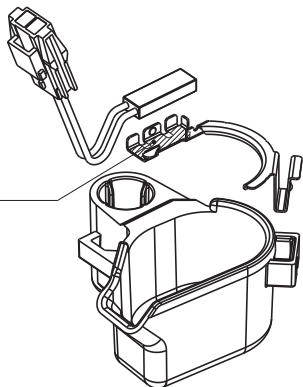
- (1) Remove the cabinet and panels. (Refer to section 1.)
- (2) Remove the inverter assembly. (Refer to section 2 (**MUZ-GS18NA, MUZ-GS18NAH, MUY-GS18NA**), section 3-1 (**Other models**).
- (3) Remove the screws fixing the reactor.
- (4) Remove the reactor.
- (5) Remove the soundproof felt.
- (6) Recover gas from the refrigerant circuit.

**NOTE:** Recover gas from the pipes until the pressure gauge shows 0 psig.

- (7) Detach the brazed part of the suction and the discharge pipe connected with compressor.
- (8) Remove the compressor nuts.
- (9) Remove the compressor.
- (10) Detach the brazed parts of 4-way valve and pipe. (Photo 19)

Figure 1

Attach the compressor protector to the protector holder with the surface on which the model name is printed facing the area hatched in the figure.



## PHOTOS/FIGURES

Photo 18

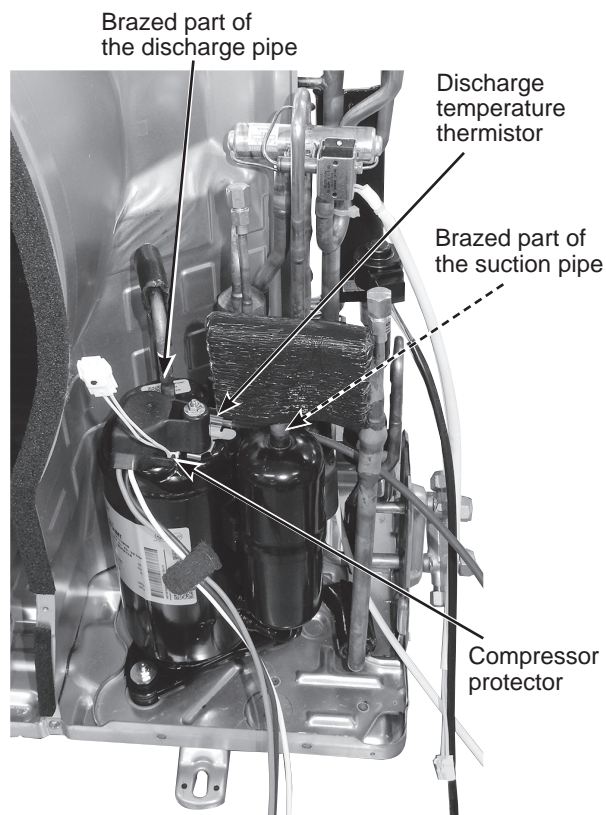
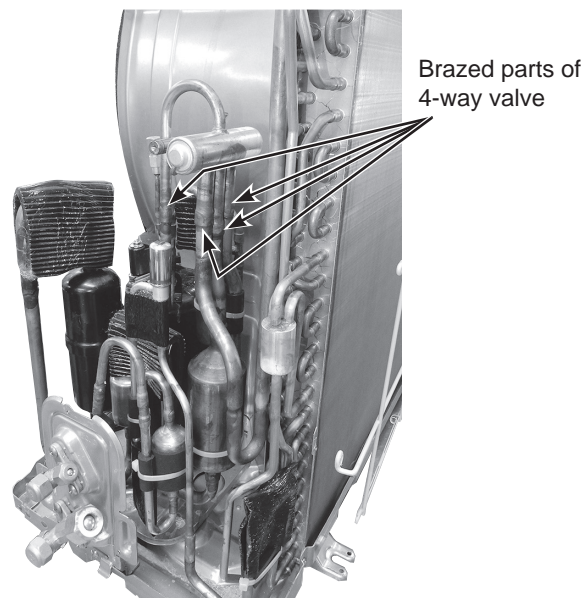
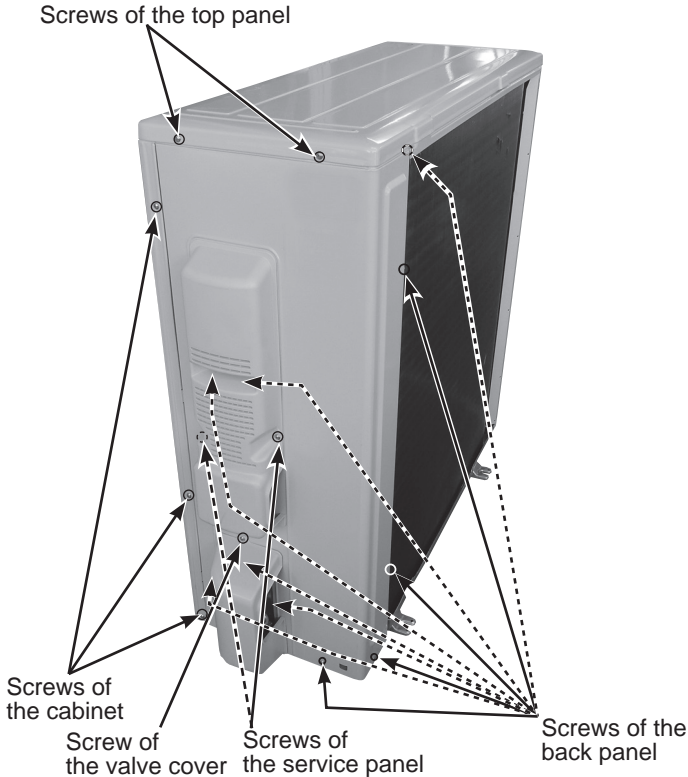
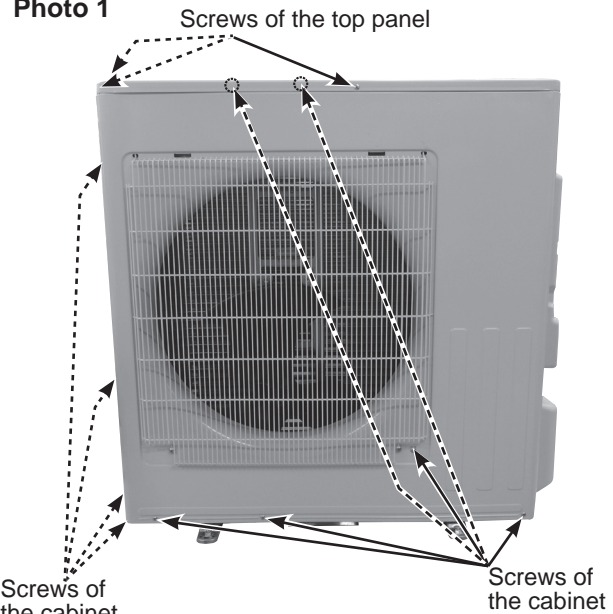

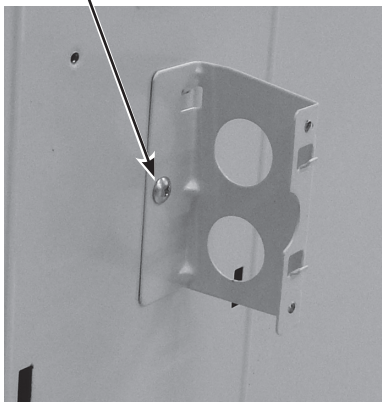


Photo 19



**11-3. MUZ-GS30NA MUZ-GS30NAH MUY-GS30NA  
MUZ-GS36NA MUZ-GS36NAH MUY-GS36NA**

**NOTE:** Turn OFF the power supply before disassembly.

OPERATING PROCEDURE	PHOTOS/FIGURES
<p><b>1. Removing the cabinet</b></p> <ol style="list-style-type: none"> <li>(1) Remove the screws of the service panel.</li> <li>(2) Remove the screws of the top panel.</li> <li>(3) Remove the screw of the valve cover.</li> <li>(4) Remove the service panel.</li> <li>(5) Remove the top panel.</li> <li>(6) Remove the valve cover.</li> <li>(7) Remove the screws fixing the conduit cover. (Photo 3)</li> <li>(8) Remove the conduit cover.</li> <li>(9) Remove the screw fixing the conduit plate. (Photo 4)</li> <li>(10) Remove the conduit plate.</li> <li>(11) Disconnect the power supply and indoor/outdoor connecting wire.</li> <li>(12) Remove the screws of the cabinet.</li> <li>(13) Remove the cabinet.</li> <li>(14) Remove the screws of the back panel.</li> <li>(15) Remove the back panel.</li> </ol> <p><b>Photo 2</b></p> 	<p><b>Photo 1</b></p>  <p><b>Photo 3</b></p>  <p><b>Photo 4</b></p> 



## OPERATING PROCEDURE

### 2. Removing the inverter assembly and inverter P.C. board

- (1) Remove the top panel, cabinet and service panel. (Refer to section 1.)
- (2) Disconnect the lead wire to the reactor and the following connectors:  
<Inverter P.C. board>  
CN602 (R.V. coil) (**MUZ**)  
CN931, CN932 (Fan motor)  
CN671 (Defrost thermistor (**MUZ**), discharge temperature thermistor and outdoor heat exchanger temperature thermistor)  
CN672 (Ambient temperature thermistor)  
CN724 (Expansion valve coil)  
CN601 (Defrost heater and heater protector)  
**(MUZ-GS30/36NAH)**
- (3) Remove the compressor connector (CN61).
- (4) Remove the screws fixing the heat sink support and the separator.
- (5) Remove the screws fixing the P.C. board support and the motor support.
- (6) Remove the fixing screws of the terminal block support and the back panel.
- (7) Remove the inverter assembly.
- (8) Remove the screws of the ground wires.
- (9) Remove the screw of the heat sink support, and the heat sink support from the P.C. board support.
- (10) Remove the screws of the terminal block support, and the screws of the ground wires. (Photo 7)
- (11) Remove the terminal block support.

## PHOTOS/FIGURES

Photo 5

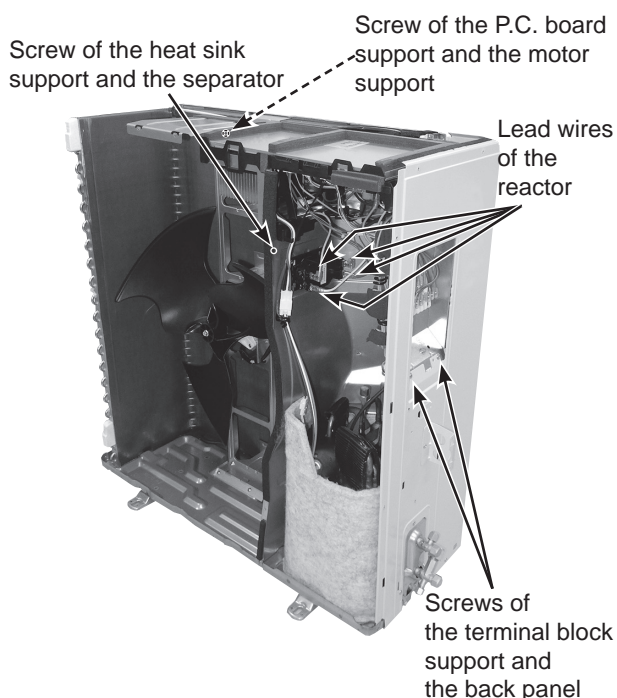
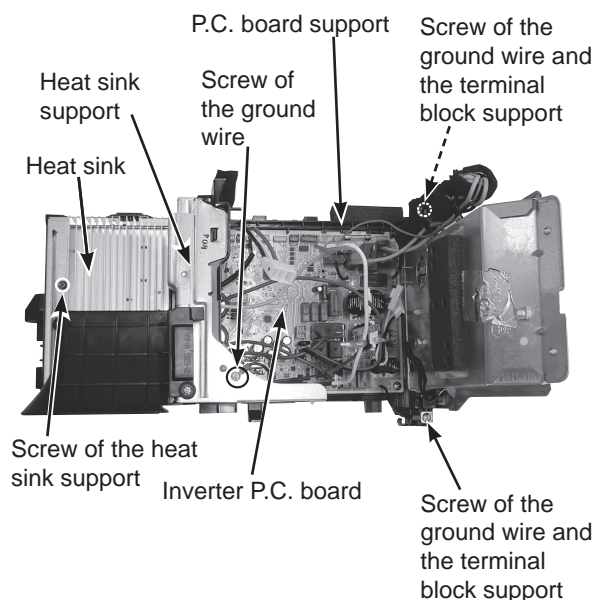


Photo 6 (Inverter assembly)





## OPERATING PROCEDURE

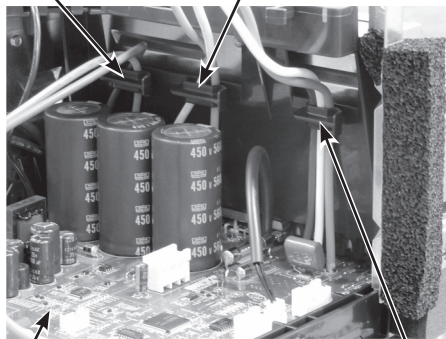
### \* Connection procedure when attaching the inverter P.C. board (Photo 8, 9)

1. Attach the heat sink support to the P.C. board support.
2. Hook the lead wires of the compressor, the reactor and the P.C. board to each hooks on the heat sink support as shown Photo 8.
3. Connect the lead wires of the expansion valve coil to the connector on the inverter P.C. board. Pull the lead wires of the expansion valve coil toward you and put them on the left hook on the P.C. board support as shown in Photo 9.

Photo 8

Hook of the lead wires of the P.C. board

Hook of the lead wires of the reactor

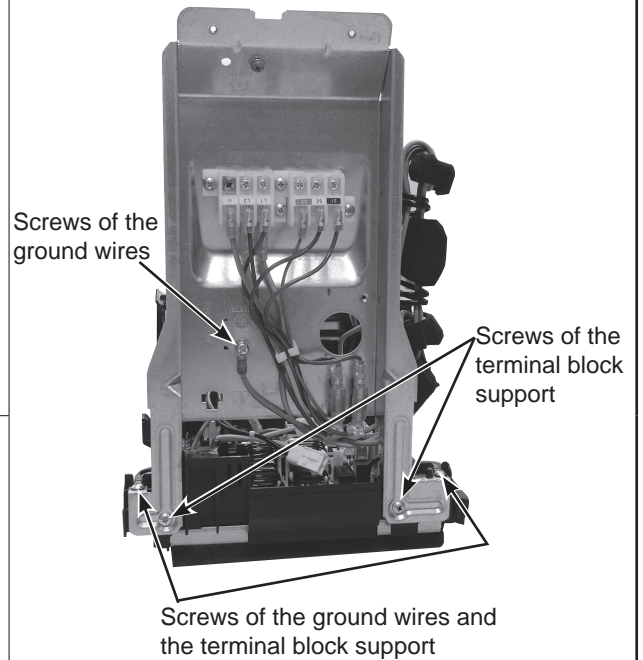


Inverter P.C. board

Hook of the lead wires of the compressor

## PHOTOS/FIGURES

Photo 7



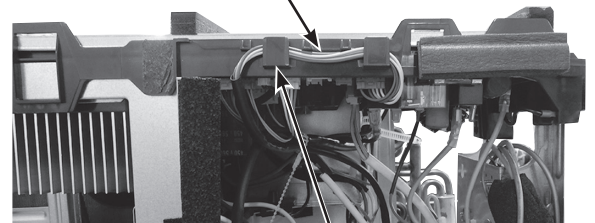
Screws of the ground wires

Screws of the terminal block support

Screws of the ground wires and the terminal block support

Photo 9

Lead wires of the expansion valve coil



Inverter P.C. board support

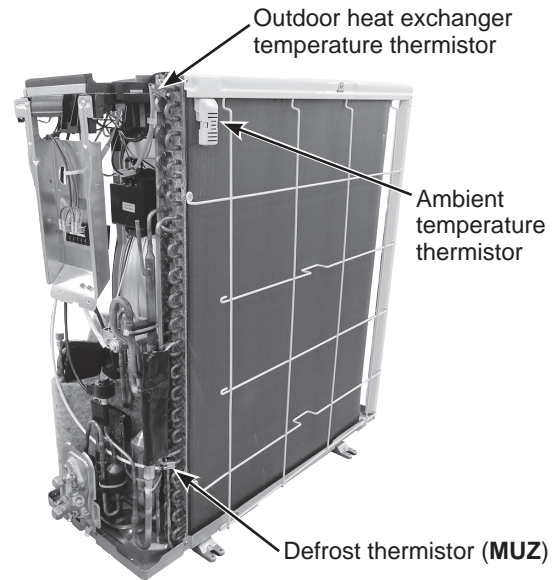
## OPERATING PROCEDURE

### 3. Removing the discharge temperature thermistor, defrost thermistor, outdoor heat exchanger temperature thermistor and ambient temperature thermistor

- (1) Remove the cabinet and panels. (Refer to section 1.)
- (2) Disconnect the lead wire to the reactor and the following connectors:  
<Inverter P.C. board>  
CN671 (Defrost thermistor (**MUZ**), discharge temperature thermistor and outdoor heat exchanger temperature thermistor)  
CN672 (Ambient temperature thermistor)
- (3) Pull out the discharge temperature thermistor from its holder. (Photo 12)
- (4) Pull out the defrost thermistor from its holder.
- (5) Pull out the outdoor heat exchanger temperature thermistor from its holder. (Photo 10)
- (6) Pull out the ambient temperature thermistor from its holder.

## PHOTOS/FIGURES

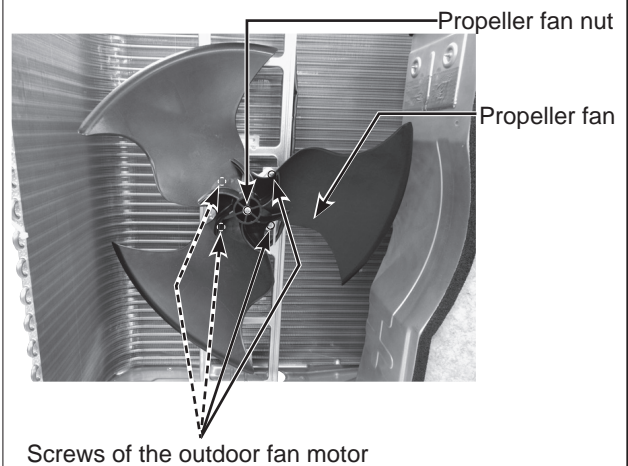
Photo 10



### 4. Removing outdoor fan motor

- (1) Remove the top panel, cabinet and service panel. (Refer to section 1.)
- (2) Disconnect the following connectors:  
<Inverter P.C. board>  
CN931, CN932 (Fan motor)
- (3) Remove the propeller fan nut.
- (4) Remove the propeller fan.
- (5) Remove the screws fixing the fan motor.
- (6) Remove the fan motor.

Photo 11



## OPERATING PROCEDURE

### 5. Removing the compressor and 4-way valve

- (1) Remove the cabinet and panels. (Refer to section 1.)
- (2) Remove the inverter assembly. (Refer to section 2.)
- (3) Remove the screws fixing the reactor.
- (4) Remove the reactor.
- (5) Remove the soundproof felt.
- (6) Recover gas from the refrigerant circuit.

**NOTE:** Recover gas from the pipes until the pressure gauge shows 0 psig.

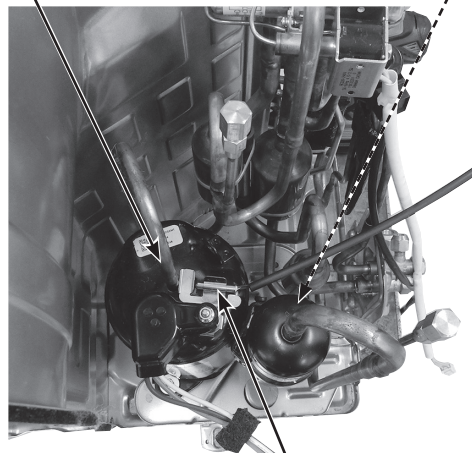
- (7) Detach the brazed part of the suction and the discharge pipe connected with compressor.
- (8) Remove the compressor nuts.
- (9) Remove the compressor.
- (10) Detach the brazed parts of 4-way valve and pipe. (Photo 13)

## PHOTOS/FIGURES

**Photo 12**

Brazed part of the discharge pipe

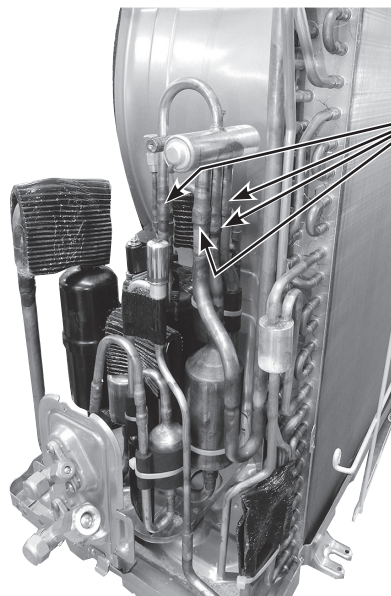
Brazed part of the suction pipe



Discharge temperature thermistor

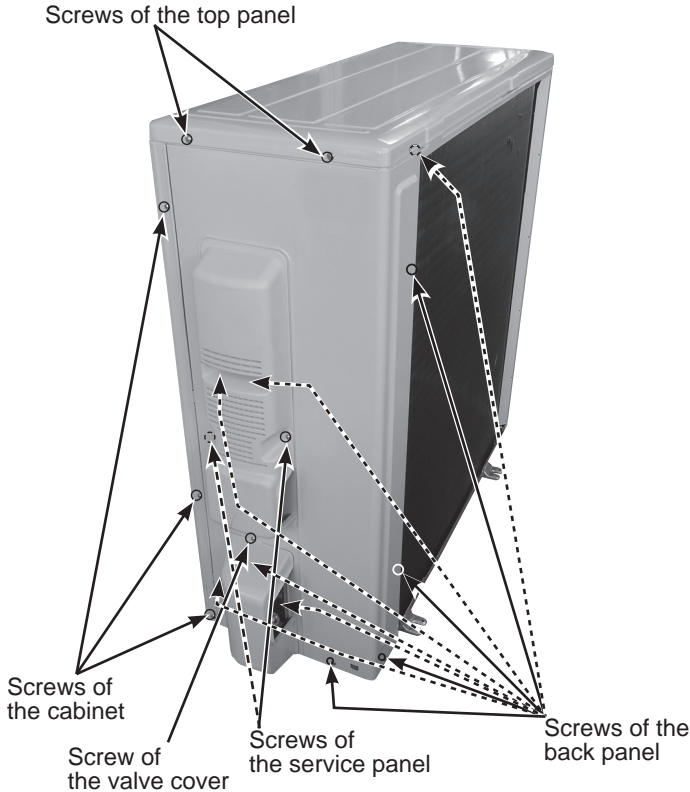
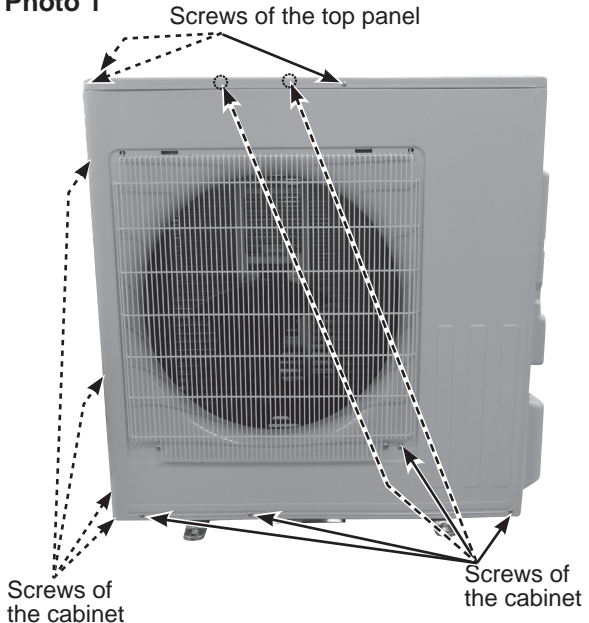
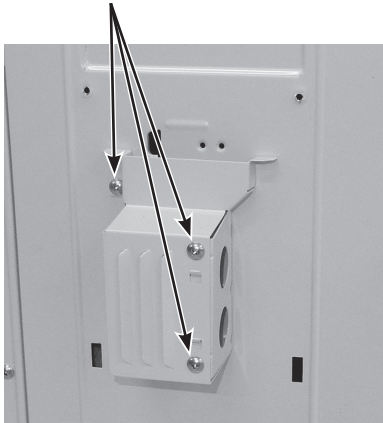
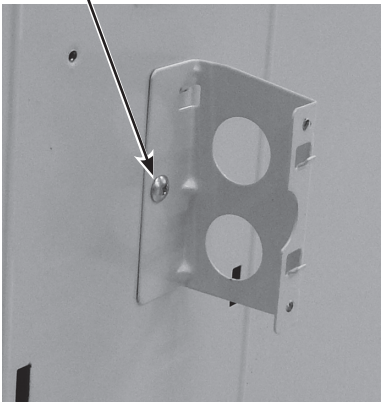
**Photo 13**

Brazed parts of 4-way valve

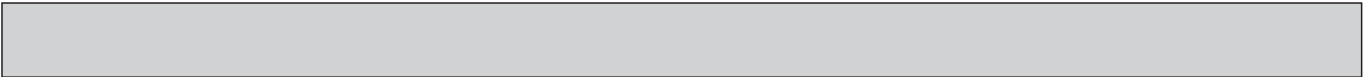


**11-4. MUZ-GS30NA2 MUZ-GS30NAH2 MUY-GS30NA2  
MUZ-GS36NA2 MUZ-GS36NAH2 MUY-GS36NA2**

**NOTE:** Turn OFF the power supply before disassembly.

OPERATING PROCEDURE	PHOTOS/FIGURES
<p><b>1. Removing the cabinet</b></p> <ol style="list-style-type: none"> <li>(1) Remove the screws of the service panel.</li> <li>(2) Remove the screws of the top panel.</li> <li>(3) Remove the screw of the valve cover.</li> <li>(4) Remove the service panel.</li> <li>(5) Remove the top panel.</li> <li>(6) Remove the valve cover.</li> <li>(7) Remove the screws fixing the conduit cover. (Photo 3)</li> <li>(8) Remove the conduit cover.</li> <li>(9) Remove the screw fixing the conduit plate. (Photo 4)</li> <li>(10) Remove the conduit plate.</li> <li>(11) Disconnect the power supply and indoor/outdoor connecting wire.</li> <li>(12) Remove the screws of the cabinet.</li> <li>(13) Remove the cabinet.</li> <li>(14) Remove the screws of the back panel.</li> <li>(15) Remove the back panel.</li> </ol> <p><b>Photo 2</b></p>  <p>Screws of the top panel</p> <p>Screws of the cabinet</p> <p>Screw of the valve cover</p> <p>Screws of the service panel</p> <p>Screws of the back panel</p>	<p><b>Photo 1</b></p>  <p>Screws of the top panel</p> <p>Screws of the cabinet</p> <p>Screws of the cabinet</p> <p><b>Photo 3</b></p>  <p>Screws of the conduit cover</p> <p><b>Photo 4</b></p>  <p>Screw of the conduit plate</p>





**OPERATING PROCEDURE**

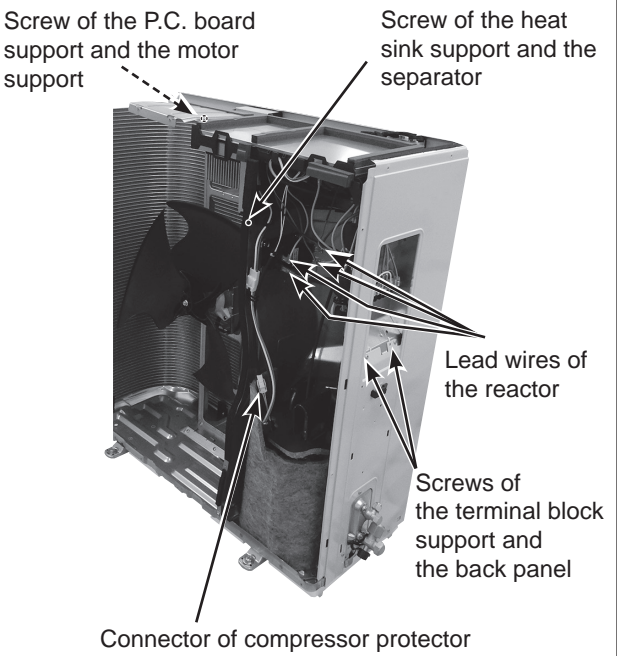
**2. Removing the inverter assembly, inverter P.C. board and fuse P.C. board (Other models)**

**2-1. Removing the inverter assembly and inverter P.C. board**

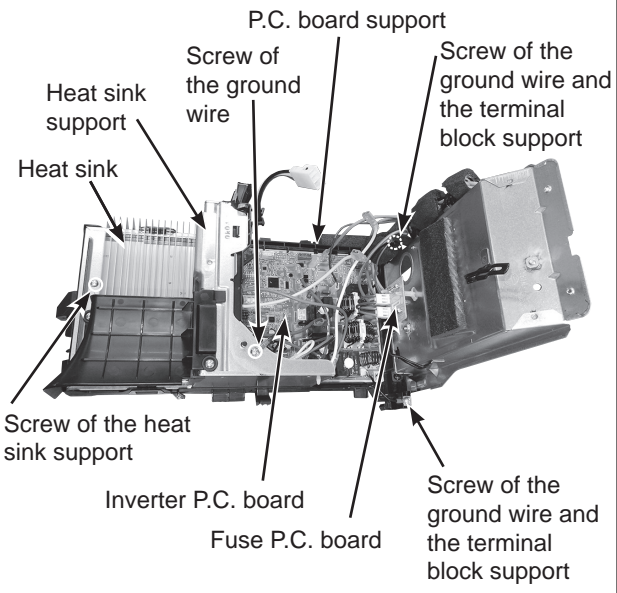
- (1) Remove the top panel, cabinet and service panel. (Refer to section 1.)
- (2) Disconnect the lead wire to the reactor and the following connectors:
  - <Inverter P.C. board>
  - CN602 (R.V. coil) **(MUZ)**
  - CN931, CN932 (Fan motor)
  - CN671 (Defrost thermistor **(MUZ)**, discharge temperature thermistor and outdoor heat exchanger temperature thermistor)
  - CN672 (Ambient temperature thermistor)
  - CN724 (Expansion valve coil)
  - CN601 (Defrost heater and heater protector) **(MUZ-GS30/36NAH2)**
  - CN64 (Compressor protector)
- (3) Remove the compressor connector (CN61).
- (4) Remove the screws fixing the heat sink support and the separator.
- (5) Remove the screws fixing the P.C. board support and the motor support.
- (6) Remove the fixing screws of the terminal block support and the back panel.
- (7) Remove the inverter assembly.
- (8) Remove the screws of the ground wires and the terminal block support.
- (9) Remove the screw of the heat sink support, and the heat sink support from the P.C. board support.

**PHOTOS/FIGURES**

**Photo 5**



**Photo 6 (Inverter assembly)**



## OPERATING PROCEDURE

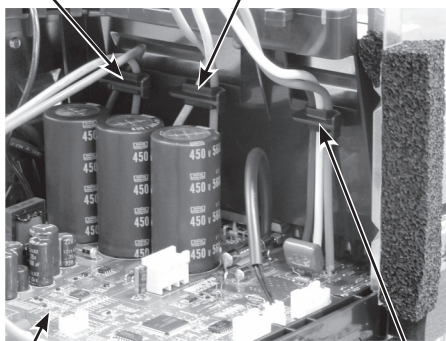
### \* Connection procedure when attaching the inverter P.C. board (Photo 8, 9)

1. Attach the heat sink support to the P.C. board support.
2. Hook the lead wires of the compressor, the reactor and the P.C. board to each hooks on the heat sink support as shown Photo 8.
3. Connect the lead wires of the expansion valve coil to the connector on the inverter P.C. board. Pull the lead wires of the expansion valve coil toward you and put them on the left hook on the P.C. board support as shown in Photo 9.

**Photo 8**

Hook of the lead wires of the P.C. board

Hook of the lead wires of the reactor

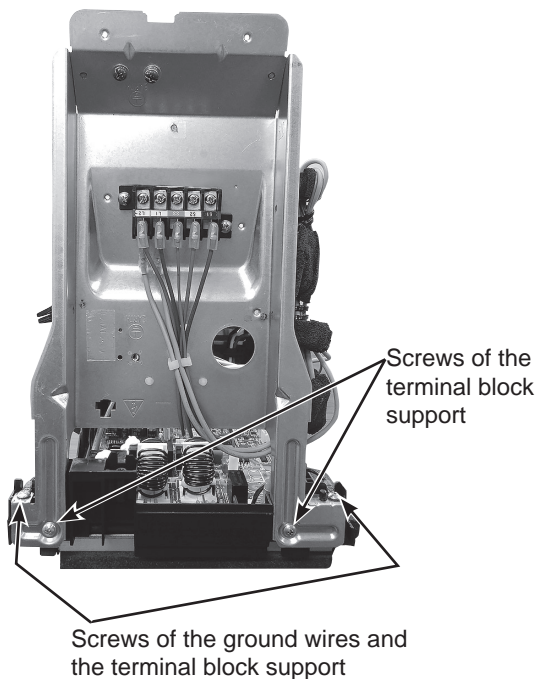


Inverter P.C. board

Hook of the lead wires of the compressor

## PHOTOS/FIGURES

**Photo 7**

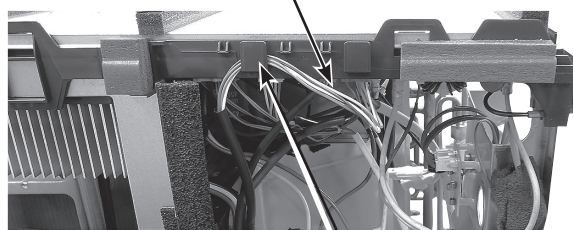


Screws of the terminal block support

Screws of the ground wires and the terminal block support

**Photo 9**

Lead wires of the expansion valve coil



Inverter P.C. board support

## OPERATING PROCEDURE

### 2-2. Removing the fuse P.C. board

- (1) Remove the top panel, cabinet and service panel. (Refer to section 1.)
- (2) Disconnect the lead wire to the reactor and the inverter P.C. board connectors. (Refer to section 2-1. (2))
- (3) Remove the compressor connector (CN61).
- (4) Remove the screws fixing the heat sink support and the separator.
- (5) Remove the screws fixing the P.C. board support and the motor support.
- (6) Remove the fixing screws of the terminal block support and the back panel.
- (7) Remove the inverter assembly.
- (8) Remove the following disconnected connectors:  
<Fuse P.C. board>  
CN65, CN66 (Terminal block)
- (9) Remove the fuse P.C. board from the supports. (Photo 11)

## PHOTOS/FIGURES

Photo 10

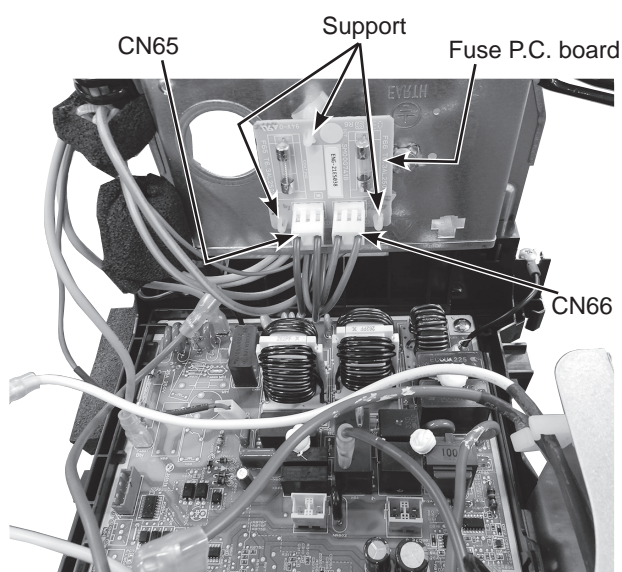
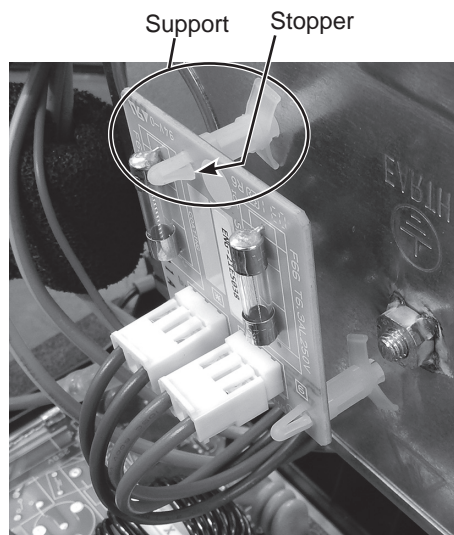


Photo 11



Pinch the stopper of the support, and push it into the hole to remove the fuse P.C. board.

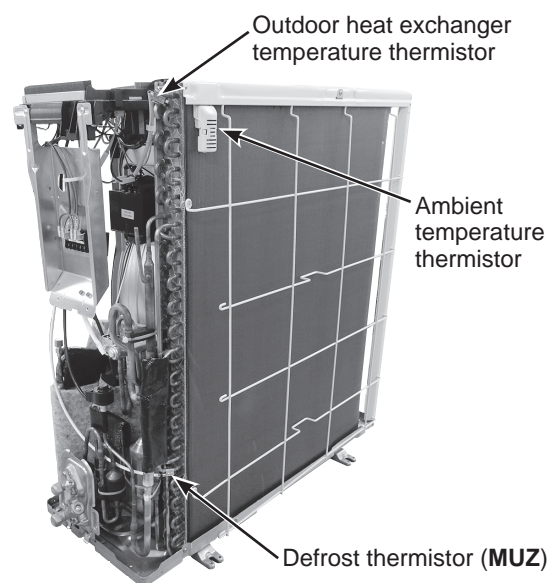
## OPERATING PROCEDURE

### 3. Removing the discharge temperature thermistor, defrost thermistor, outdoor heat exchanger temperature thermistor and ambient temperature thermistor

- (1) Remove the cabinet and panels. (Refer to section 1.)
- (2) Disconnect the lead wire to the reactor and the following connectors:  
<Inverter P.C. board>  
CN671 (Defrost thermistor (**MUZ**), discharge temperature thermistor and outdoor heat exchanger temperature thermistor)  
CN672 (Ambient temperature thermistor)
- (3) Pull out the discharge temperature thermistor from its holder. (Photo 14)
- (4) Pull out the defrost thermistor from its holder.
- (5) Pull out the outdoor heat exchanger temperature thermistor from its holder. (Photo 12)
- (6) Pull out the ambient temperature thermistor from its holder.

## PHOTOS/FIGURES

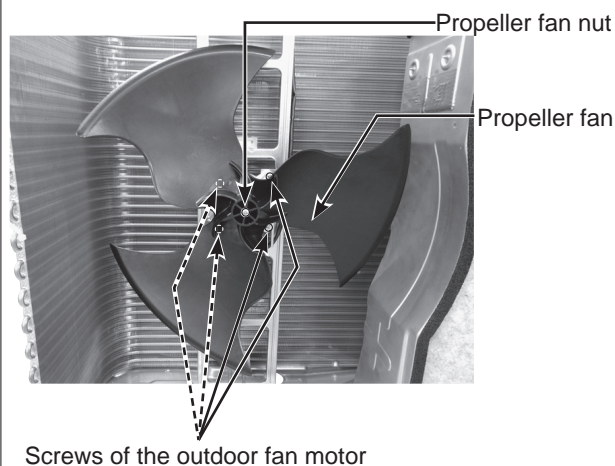
Photo 12



### 4. Removing outdoor fan motor

- (1) Remove the top panel, cabinet and service panel. (Refer to section 1.)
- (2) Disconnect the following connectors:  
<Inverter P.C. board>  
CN931, CN932 (Fan motor)
- (3) Remove the propeller fan nut.
- (4) Remove the propeller fan.
- (5) Remove the screws fixing the fan motor.
- (6) Remove the fan motor.

Photo 13





## OPERATING PROCEDURE

### 5. Removing the compressor and 4-way valve

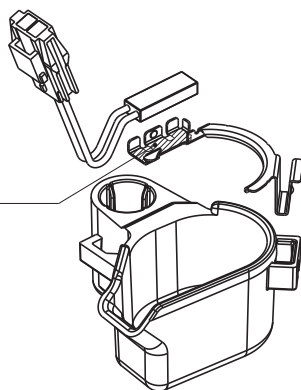
- (1) Remove the cabinet and panels. (Refer to section 1.)
- (2) Remove the inverter assembly. (Refer to section 2.)
- (3) Remove the screws fixing the reactor.
- (4) Remove the reactor.
- (5) Remove the soundproof felt.
- (6) Recover gas from the refrigerant circuit.

**NOTE:** Recover gas from the pipes until the pressure gauge shows 0 psig.

- (7) Detach the brazed part of the suction and the discharge pipe connected with compressor.
- (8) Remove the compressor nuts.
- (9) Remove the compressor.
- (10) Detach the brazed parts of 4-way valve and pipe. (Photo 15)

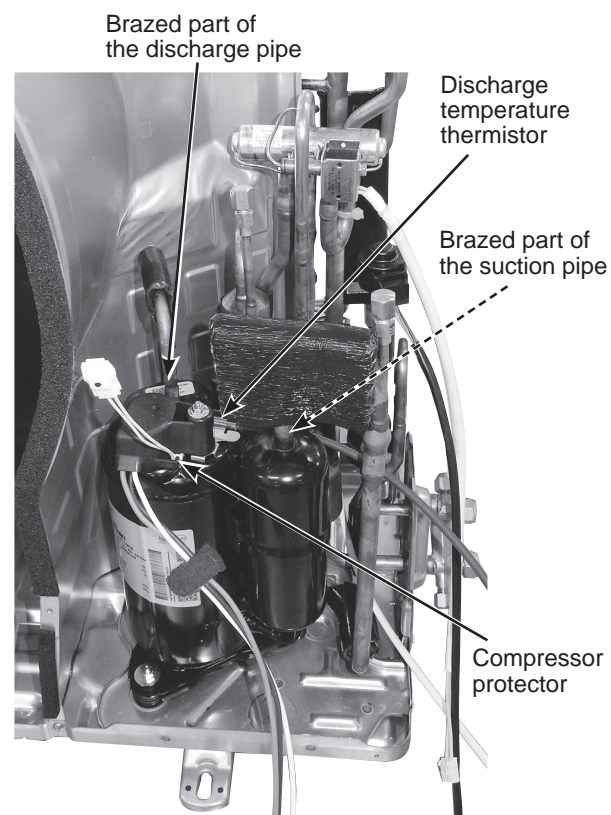
**Figure 1**

Attach the compressor protector to the protector holder with the surface on which the model name is printed facing the area hatched in the figure.

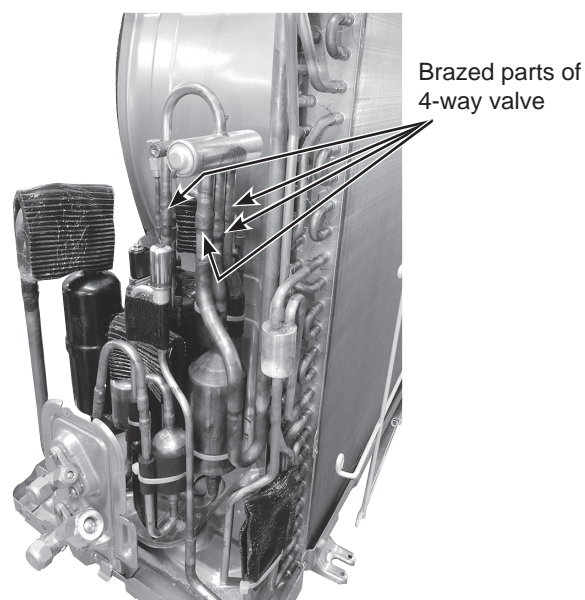


## PHOTOS/FIGURES

**Photo 14**



**Photo 15**  
Except MUY-GS30/36NA2



# **mitsubishi electric corporation**

HEAD OFFICE: TOKYO BUILDING, 2-7-3, MARUNOUCHI, CHIYODA-KU, TOKYO 100-8310, JAPAN

© Copyright 2021 MITSUBISHI ELECTRIC CORPORATION

Issued: Oct. 2022. No. OBH875 REVISED EDITION-B

Issued: Jun. 2021. No. OBH875 REVISED EDITION-A

Published: Jan. 2021. No. OBH875

Made in Japan

Specifications are subject to change without notice.