

August 2006

No. OC343

REVISED EDITION-A

TECHNICAL & SERVICE MANUAL

CITY MULTI Series Ceiling Suspended R410A / R22

[Models]

PCFY-P15NGMU-E
PCFY-P24NGMU-E
PCFY-P30NGMU-E
PCFY-P36NGMU-E

Revision:

- RoHS PARTS LIST is added.
- Some descriptions have been modified.

- Please void OC343.

NOTE:

- This manual describes only service data of the indoor units.
- RoHS compliant products have <G> mark on the spec name plate.
- For servicing of RoHS compliant products, refer to the RoHS PARTS LIST.

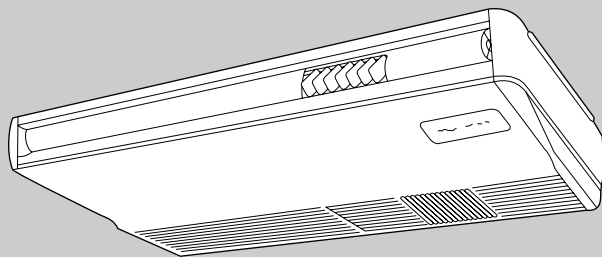

INDOOR UNIT

CONTENTS

1. FEATURES	2
2. PART NAMES AND FUNCTIONS	4
3. SPECIFICATIONS	6
4. OUTLINES AND DIMENSIONS.....	9
5. WIRING DIAGRAM.....	13
6. REFRIGERANT SYSTEM DIAGRAM ..	14
7. MICROPROCESSOR CONTROL.....	15
8. TROUBLE SHOOTING.....	22
9. DISASSEMBLY PROCEDURE.....	29
10. PARTS LIST.....	33
11. RoHS PARTS LIST	40
12. OPTIONAL PARTS	47



CITY MULTI

1

FEATURES

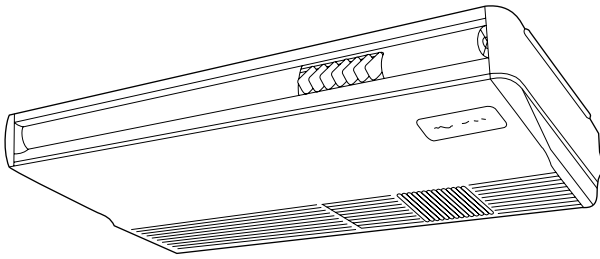

Indoor unit

Models Cooling capacity / Heating capacity

PCFY-P15NGMU-E	15,000 / 17,000 Btu/h
PCFY-P24NGMU-E	24,000 / 27,000 Btu/h
PCFY-P30NGMU-E	30,000 / 34,000 Btu/h
PCFY-P36NGMU-E	36,000 / 40,000 Btu/h

1. EASY TO CLEAN ; FLOCKLESS VANE

With our original air current control mechanism, a flockless vane is newly adapted.

The flockless vane prevents the condensation on the vane.

By changing the vane to the flockless type, the unit can be cleaned much easier with mild household detergent.

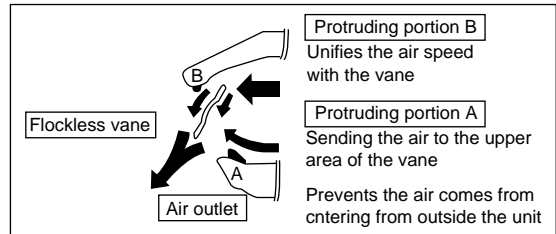

2. NEW MATERIALS FOR BETTER OIL RESISTANCE

We have changed the materials of grill, filter, fan and fan casing from ABS to P.P. (polypropylene) for better oil resistance. As a result, oil crazing is cut in half.

3. SIMPLIFIED INSTALLATION WORK (DIRECT SUSPENDING METHOD)

Simplified the installation work by changing the suspending method to the direct suspending method (suspending the unit directly from the suspension fixture).

In this way, the unit can be attached to the suspension fixture without removing the installation parts off (Only the side cover is removed). This method is much simpler than the "One-time installation method".

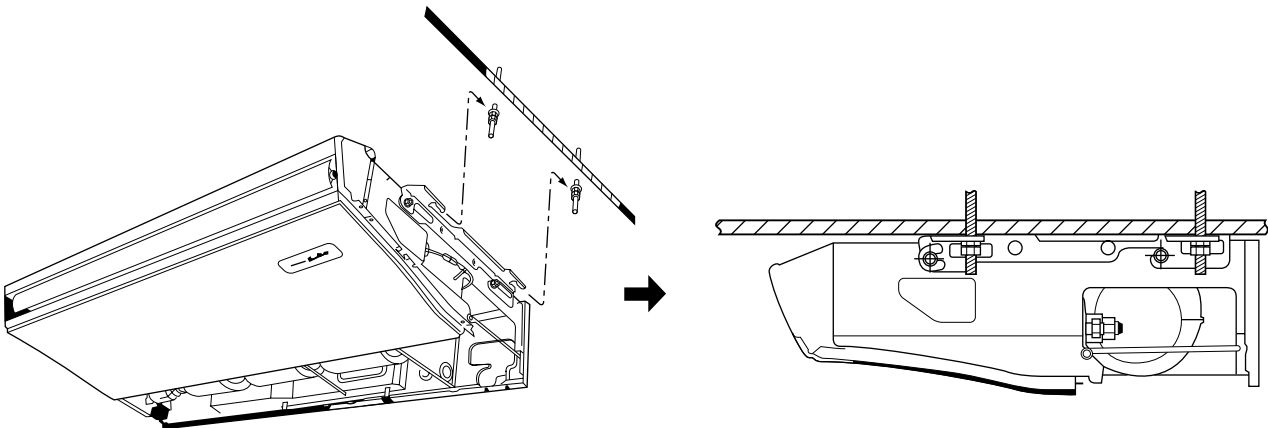

4. IMPROVING EFFICIENCY OF PIPING WORK

① Removed the knockout work by separating the piping space from the air outlet for efficiency of the piping work.

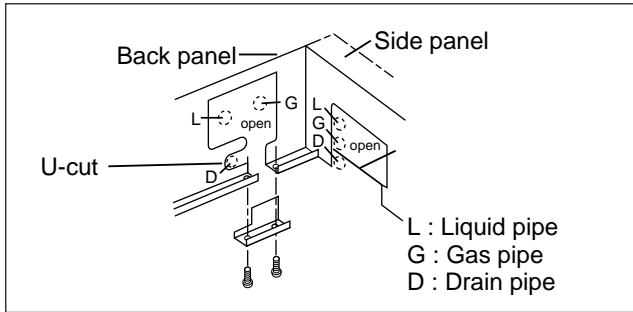

* Knockout work is needed for the top part. When optional drain-up machine is installed, the refrigerant pipe exits out from the top.

② Improved the flexibility by making it possible for drainage pipe to exit not only from the right side back but also from the left side back.

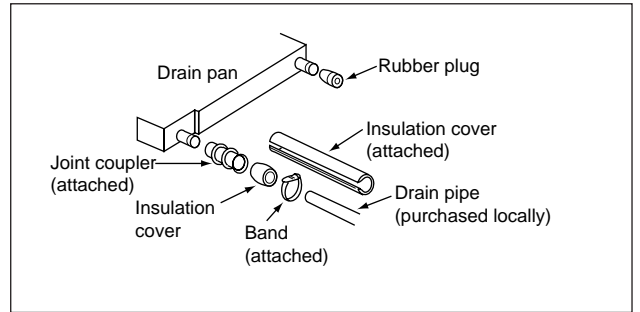

* Please move the rubber plug for the unit to the right joint when drainage pipe exits from the left side.

5. EASY MAINTENANCE FILTER ; NO MAINTENANCE NECESSARY FOR 2500 HOURS

The new long-life air filter can be used continuously 2500 hours without maintenance (at general office use).

2

PART NAMES AND FUNCTIONS

● Indoor Unit

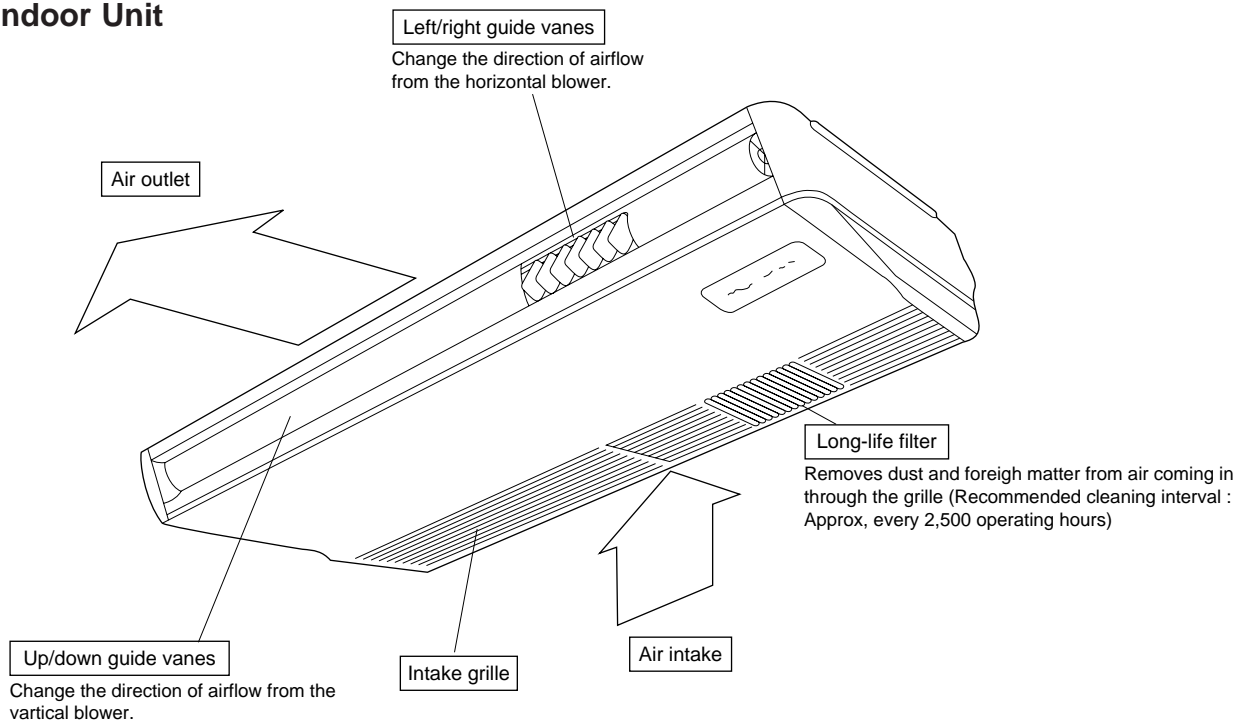

● Remote controller [PAR-21MAA]

- Once the controls are set, the same operation mode can be repeated by simply pressing the ON/OFF button.

● Operation buttons

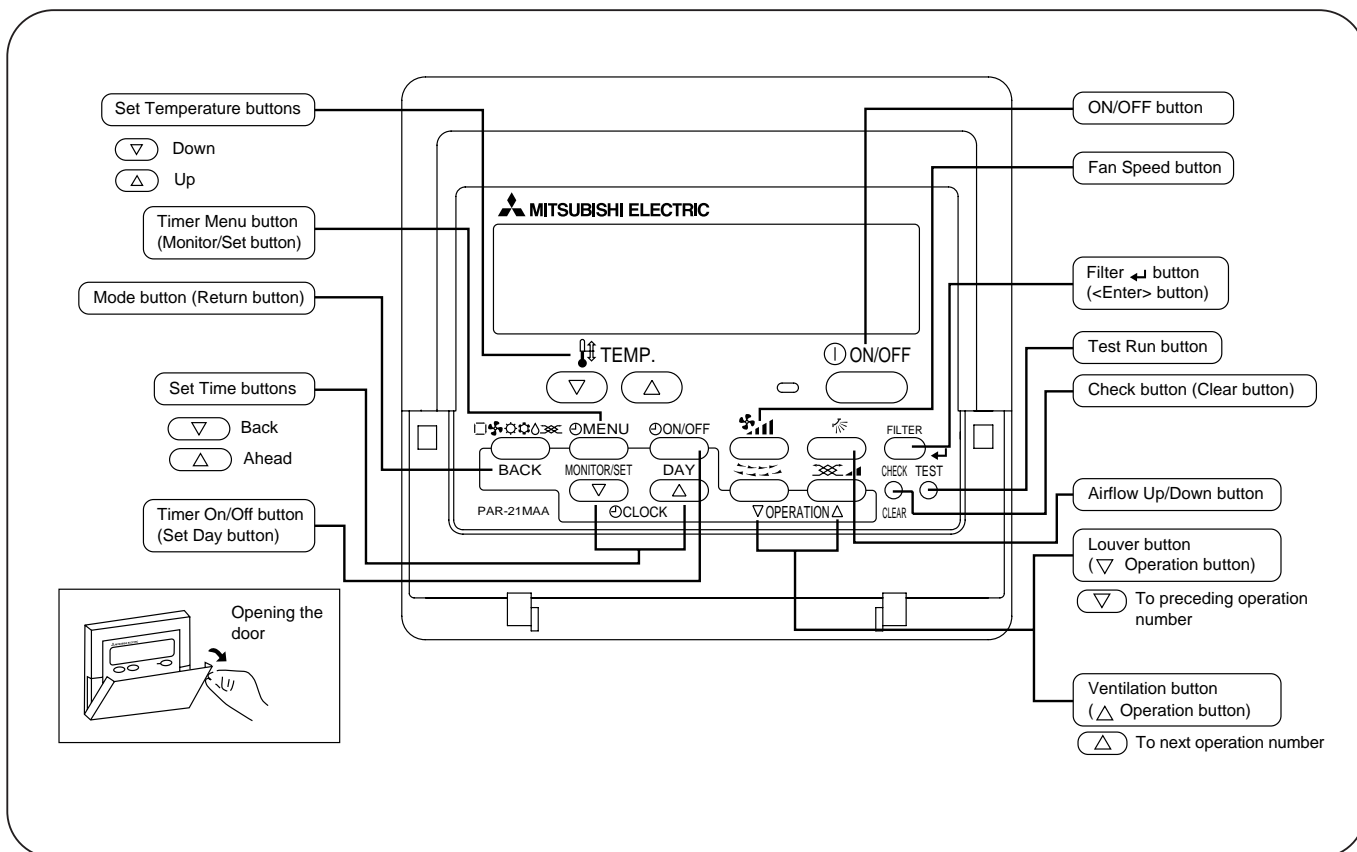

● Display

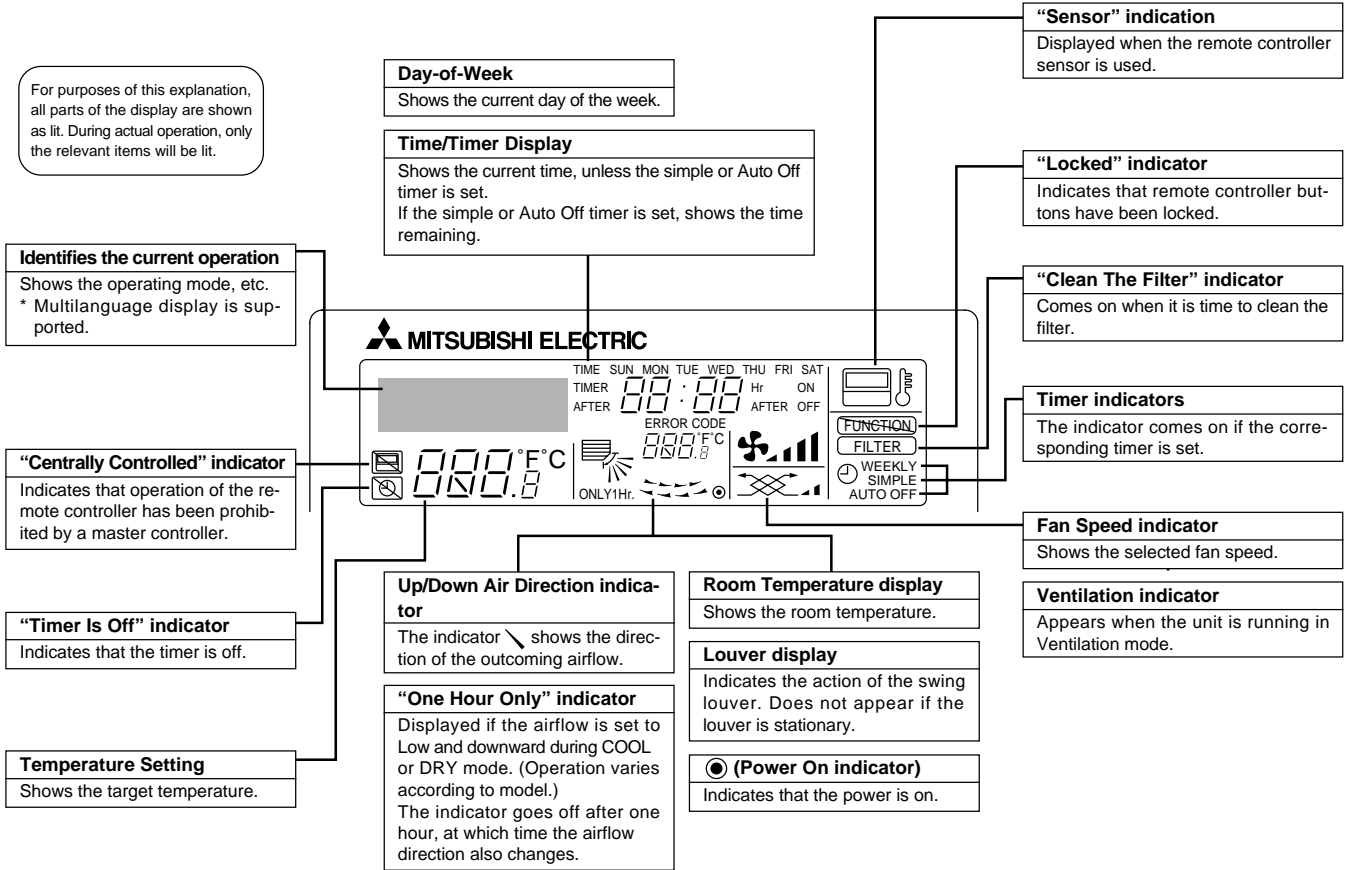

Caution

- Only the Power on indicator lights when the unit is stopped and power supplied to the unit.
- If you press a button for a feature that is not installed at the indoor unit, the remote controller will display the “Not Available” message.
If you are using the remote controller to operate multiple indoor units, this message will appear only if the feature is not present at every unit connected.
- When power is turned ON for the first time, it is normal that “PLEASE WAIT” is displayed on the room temperature indication (For max. 2minutes). Please wait until this “PLEASE WAIT” indication disappear then start the operation.

3

SPECIFICATIONS

3-1. SPECIFICATIONS

Item		PCFY-P15NGMU-E	PCFY-P24NGMU-E	PCFY-P30NGMU-E	PCFY-P36NGMU-E		
Power	V•Hz	Single phase 208/230V 60Hz					
Cooling capacity	Btu/h	15,000	24,000	30,000	36,000		
Heating capacity	Btu/h	17,000	27,000	34,000	40,000		
Electric characteristic	Input	Cooling	kW	0.08	0.09	0.23	0.27
		Heating	kW	0.08	0.09	0.23	0.27
	Current	Cooling	A	0.40	0.45	1.12	1.32
		Heating	A	0.40	0.45	1.12	1.32
Exterior (munsell symbol)	—	Unit : Munsell<0.70Y 8.59/0.97>					
Dimensions	Height	in.	8-9/32		10-5/8		
	Width	in.	39-5/8	51-9/16		63-3/4	
	Depth	in.	26-25/32				
Heat exchanger	—	Cross fin(Aluminum plate fin and copper tube)					
Fan	Fan X No	—	Sirocco fan X 2	Sirocco fan X 3		Sirocco fan X 4	
	Air flow ※2	DRY	CFM	280-350-390-420	420-490-570-640	640-710-810-880	920-990-1120-1230
		WET	CFM	250-310-350-380	380-470-530-600	600-670-770-830	870-930-1050-1160
	External static pressure	Pa	0				
	Fan motor output	kW	0.054	0.07	0.09	0.15	
Air filter	—	PP honey comb					
Pipe dimensions	Gas side	in.	1/2"	5/8"		5/8" / 3/4"(compatible)	
	Liquid side	in.	1/4"	3/8"		3/8"	
Unit drain pipe size	in.	1" I.D. (PVC pipe VP-20 connectable)					
Noise level ※2	dB	29-33-36-38	32-34-37-39	36-38-41-43	37-39-42-44		
Product weight	lb	60	75	82	95		

Note 1. Rating conditions

Cooling : Indoor : D.B. 80°F W.B. 67°F
 outdoor : D.B. 95°F W.B. 75°F
 Heating : Indoor : D.B. 70°F
 outdoor : D.B. 47°F W.B. 43°F

※ 2. Air flow and the noise level are indicated as Low - Medium2 - Medium1 - High.

3-2. ELECTRICAL PARTS SPECIFICATIONS

Model Parts name	Symbol	PCFY-P15NGMU-E	PCFY-P24NGMU-E	PCFY-P30NGMU-E	PCFY-P36NGMU-E
Room temperature thermistor	TH21	Resistance 30°F/15.8kΩ, 50°F/9.6kΩ, 70°F/6.0kΩ, 80°F/4.8kΩ, 90°F/3.9kΩ, 100°F/3.2kΩ			
Liquid pipe temperature thermistor	TH22	Resistance 30°F/15.8kΩ, 50°F/9.6kΩ, 70°F/6.0kΩ, 80°F/4.8kΩ, 90°F/3.9kΩ, 100°F/3.2kΩ			
Gas pipe temperature thermistor	TH23	Resistance 30°F/15.8kΩ, 50°F/9.6kΩ, 70°F/6.0kΩ, 80°F/4.8kΩ, 90°F/3.9kΩ, 100°F/3.2kΩ			
Fuse (Indoor controller board)	FUSE	250V 6A			
Fan motor (with inner-thermostat)	MF	4-Pole Output 54W D09B4P54MS	4-Pole Output 70W D09C4P70MS	4-Pole Output 90W D10C4P90MS	4-Pole Output 150W D10D4P150MS
		Inner-thermostat OFF 266°F ±41°F			
Fan motor capacitor	C1	3μF X 440V	4μF X 440V	5μF X 440V	7μF X 440V
Vane motor	MV	MP35EA DC12V		MP42EA DC12V	
Linear expansion valve	LEV	DC12V Stepping motor drive port φ3.2 (0~2000pulse) EDM-40YGME		DC12V Stepping motor drive port φ5.2 (0~2000pulse) EDM-80YGME	
Power supply terminal block	TB2	(L1, L2, GR) 330V 30A			
Transmission terminal block	TB5	(M1, M2, S) 250V 20A			
MA remote controller terminal block	TB15	(1, 2) 250V 10A			

3-3. NOISE CRITERION CURVES

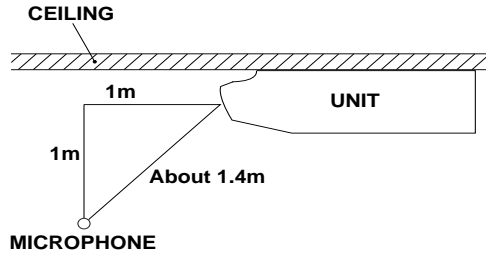

PCFY-P15NGMU-E

NOTCH	SPL(dB)	LINE
High	38	○—○
Medium1	36	△—△
Medium2	33	▲—▲
Low	29	●—●

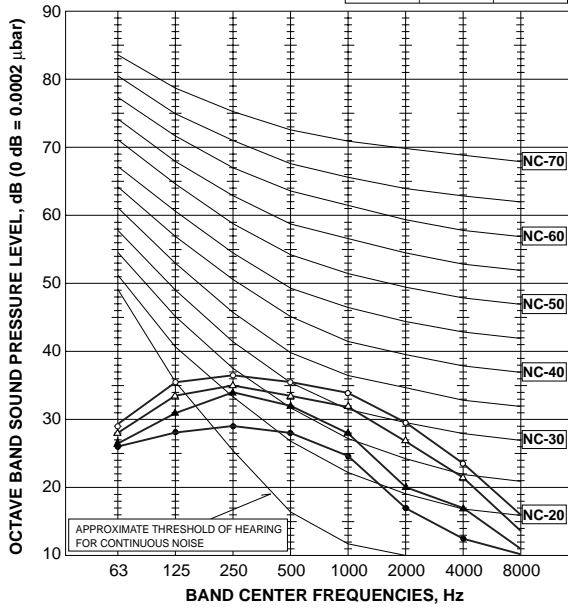

PCFY-P24NGMU-E

NOTCH	SPL(dB)	LINE
High	39	○—○
Medium1	37	△—△
Medium2	34	▲—▲
Low	32	●—●

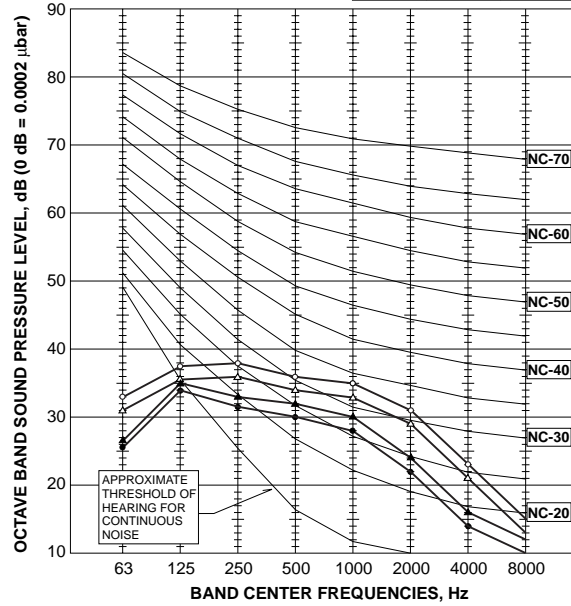

PCFY-P30NGMU-E

NOTCH	SPL(dB)	LINE
High	43	○—○
Medium1	41	△—△
Medium2	38	▲—▲
Low	36	●—●

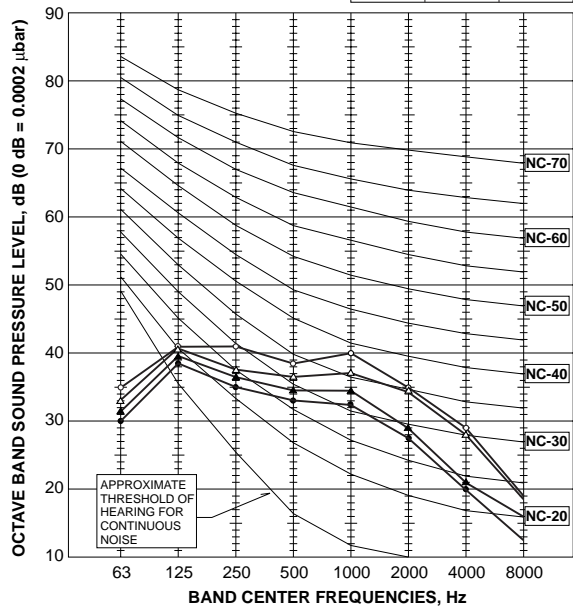

PCFY-P36NGMU-E

NOTCH	SPL(dB)	LINE
High	44	○—○
Medium1	42	△—△
Medium2	39	▲—▲
Low	37	●—●

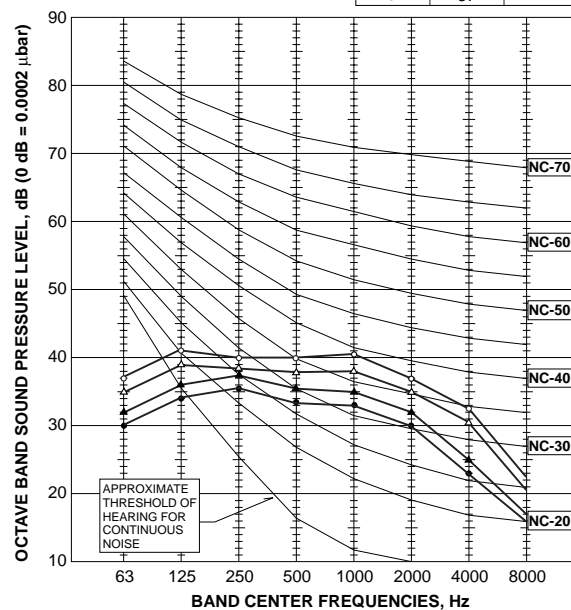

INDOOR UNIT
PCFY-P15NGMU-E

Unit: in.(mm)

- NOTES.**
1. Use M10 or W3/8 screw for anchor bolt.
 2. Please be sure when installing the drain-up machine (option parts), refrigerant pipe will be only upper drain pipe arrangement.

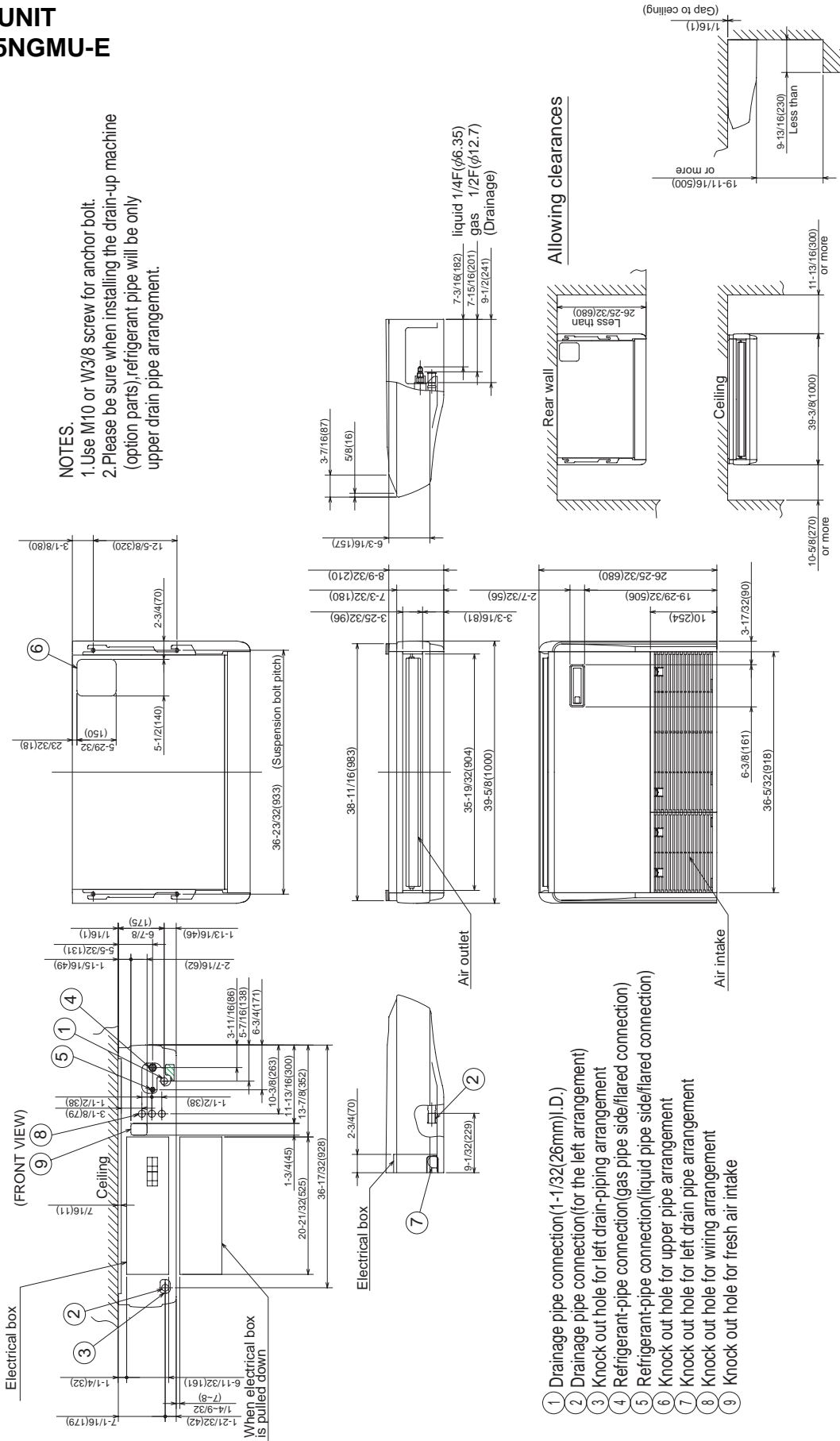

- 1 Drainage pipe connection(1-1/32(26mm))I.D.)
- 2 Drainage pipe connection(for the left arrangement)
- 3 Knock out hole for left drain-piping arrangement
- 4 Refrigerant-pipe connection(gas pipe side/flared connection)
- 5 Refrigerant-pipe connection(liquid pipe side/flared connection)
- 6 Knock out hole for upper pipe arrangement
- 7 Knock out hole for left drain pipe arrangement
- 8 Knock out hole for wiring arrangement
- 9 Knock out hole for fresh air intake

PCFY-P24NGMU-E

Unit : in.(mm)

- NOTES.**
1. Use M10 or W3/8 screw for anchor bolt.
 2. Please be sure when installing the drain-up machine (option parts), refrigerant pipe will be only upper drain pipe arrangement.

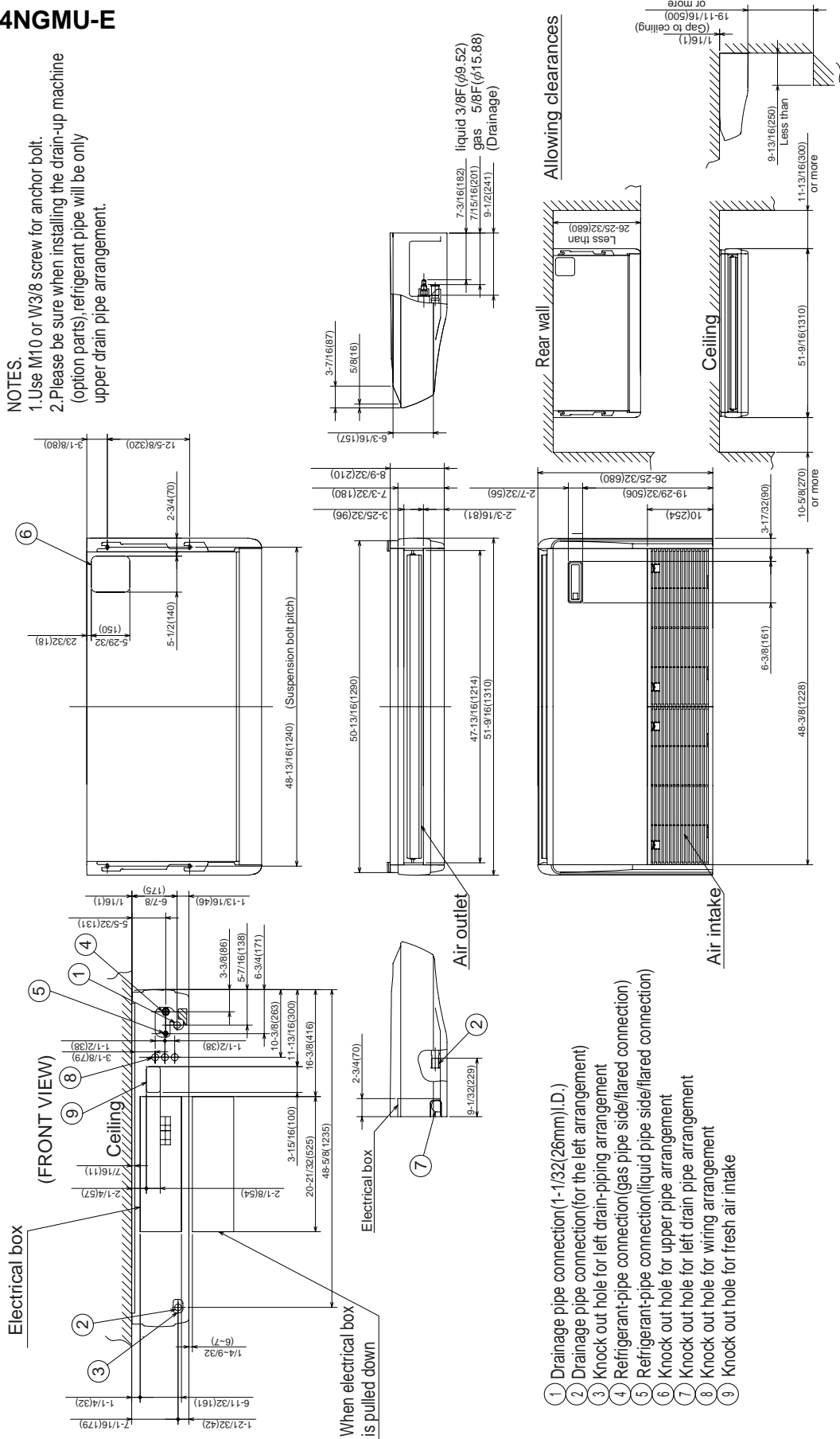

- 1 Drainage pipe connection (1-1/32(26mm) I.D.)
- 2 Drainage pipe connection (for the left arrangement)
- 3 Knock out hole for left drain-piping arrangement
- 4 Refrigerant-pipe connection (gas pipe side/flared connection)
- 5 Refrigerant-pipe connection (liquid pipe side/flared connection)
- 6 Knock out hole for upper pipe arrangement
- 7 Knock out hole for left drain pipe arrangement
- 8 Knock out hole for wiring arrangement
- 9 Knock out hole for fresh air intake

PCFY-P30NGMU-E

Unit: in.(mm)

- NOTES.**
1. Use M10 or W3/8 screw for anchor bolt.
 2. Please be sure when installing the drain-up machine (option parts), refrigerant pipe will be only upper drain pipe arrangement.

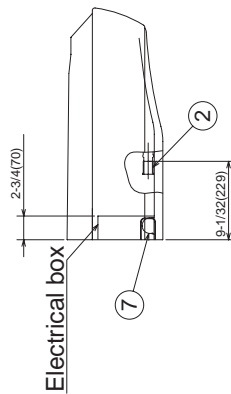
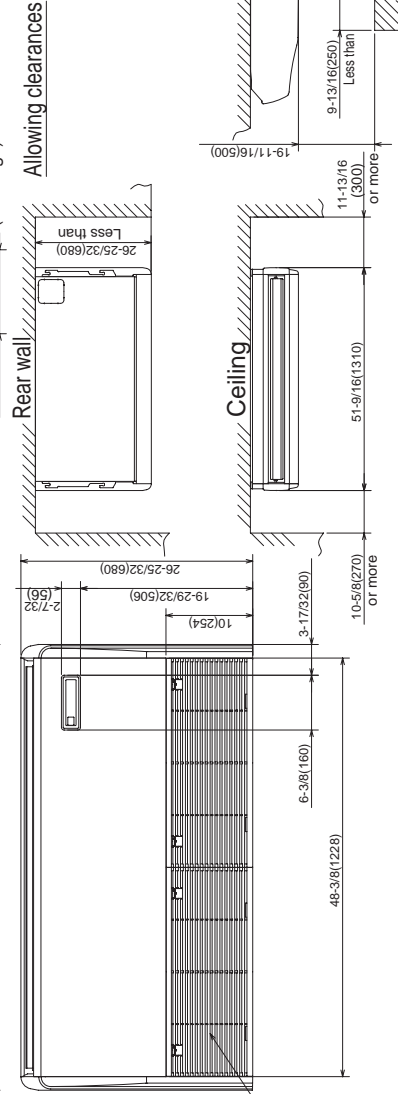
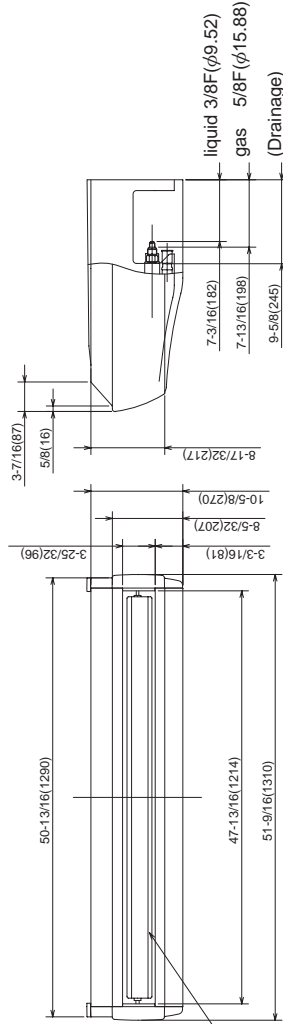
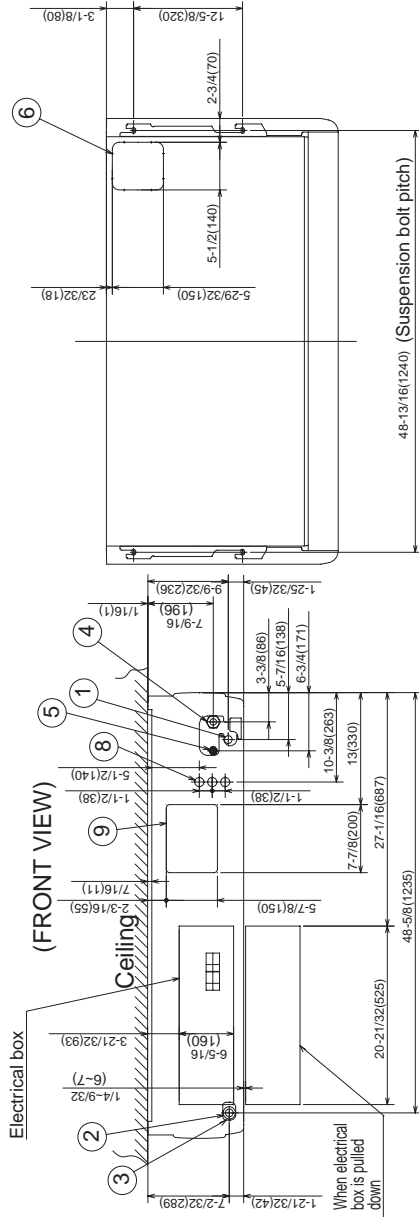

- 1 Drainage pipe connection (1-1/32(26mm) I.D.)
- 2 Drainage pipe connection (for the left arrangement)
- 3 Knock out hole for left drain-piping arrangement
- 4 Refrigerant-pipe connection (gas pipe side/flared connection)
- 5 Refrigerant-pipe connection (liquid pipe side/flared connection)
- 6 Knock out hole for upper pipe arrangement
- 7 Knock out hole for left drain pipe arrangement
- 8 Knock out hole for wiring arrangement
- 9 Knock out hole for fresh air intake

PCFY-P36NGMU-E

Unit : in.(mm)

NOTES.
 1. Use M10 or W3/8 screw for anchor bolt.
 2. Please be sure when installing the drain-up machine (option parts), refrigerant pipe will be only upper drain pipe arrangement.

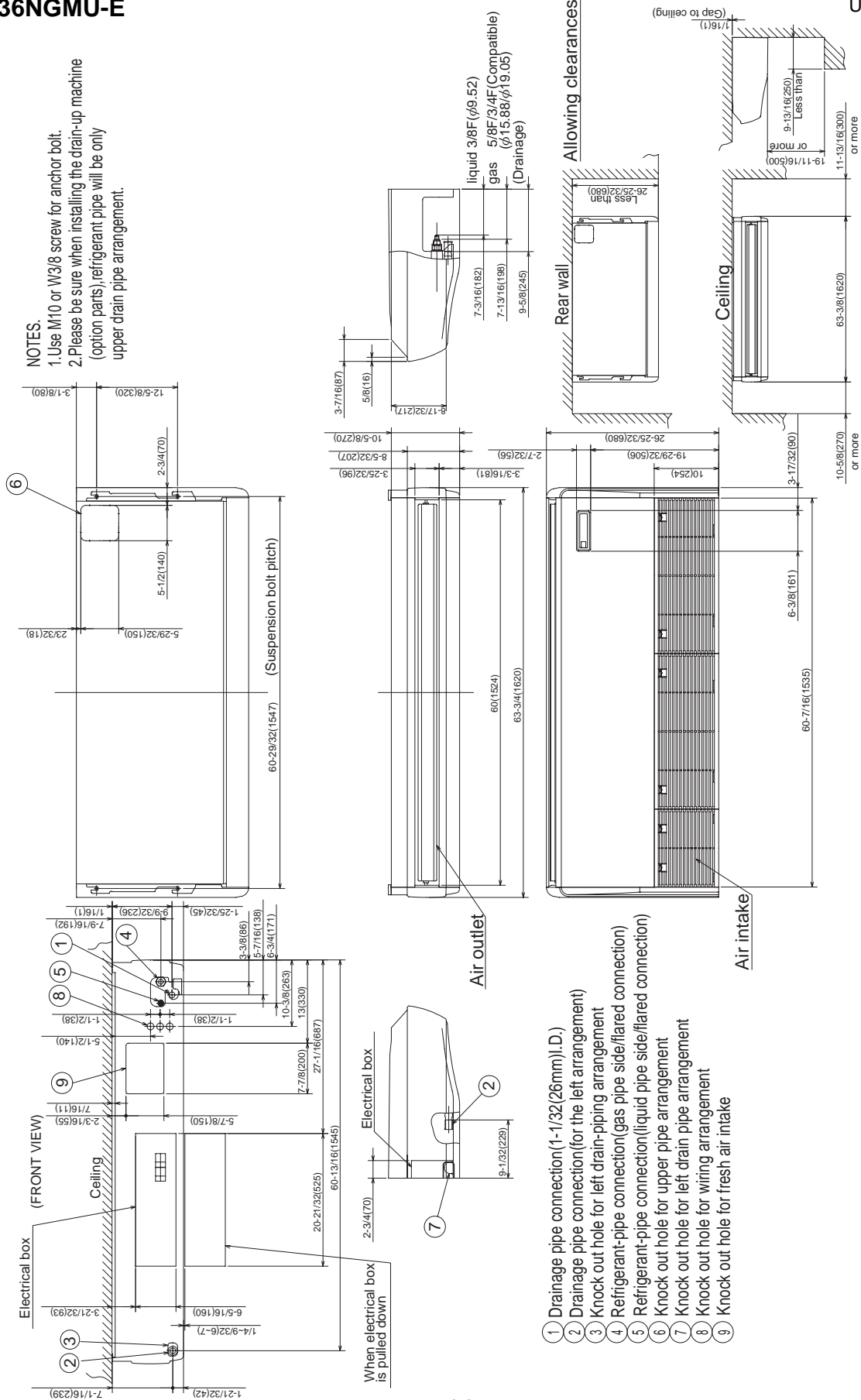

- ① Drainage pipe connection(1-1/32(26mm)I.D.)
- ② Drainage pipe connection(for the left arrangement)
- ③ Knock out hole for left drain-piping arrangement
- ④ Refrigerant-pipe connection(gas pipe side/flared connection)
- ⑤ Refrigerant-pipe connection(liquid pipe side/flared connection)
- ⑥ Knock out hole for upper pipe arrangement
- ⑦ Knock out hole for left drain pipe arrangement
- ⑧ Knock out hole for wiring arrangement
- ⑨ Knock out hole for fresh air intake

RG01N982

PCFY-P36NGMU-E

PCFY-P15NGMU-E PCFY-P24NGMU-E PCFY-P30NGMU-E PCFY-P36NGMU-E

Legend

Symbol	Name	Symbol	Name	Symbol	Name
I. B	Indoor controller board	P. B	INDOOR POWER BOARD	A. B	Circuit board Address
CN24	Connector	C1	Capacitor (fan motor)	SW1	Switch Mode selection
CN32		LEV	Linear expansion valve	SW5	Switch Voltage selection
CN51		MF	Fan motor (with inner thermo)	SW11	Switch Address setting 1st digit
CN52		MV	Vane motor	SW12	Switch Address setting 2nd digit
CNP		TH21	Thermistor Room temp, detection (32°F/15KΩ, 77°F/5.4KΩ)	SW14	Switch Connection No.
F.C	Fan phase control			SWA	Ceiling height Selector
FUSE	FUSE (6A/250V)	TH22	Thermistor Pipe temp, detection/liquid (32°F/15KΩ, 77°F/5.4KΩ)	SWC	Option Selector
SW2	Switch Capacity code	TH23	Thermistor Pipe temp, detection/Gas (32°F/15KΩ, 77°F/5.4KΩ)		
SW3	Switch Mode selection				
SW4	Switch Model selection				
X1	Aux.Relay Drain-up machine	TB2	Terminal block Power supply		
X4	Aux.Relay Fan motor	TB5	Terminal block Transmission		
ZNR	Varistor	TB15	Terminal block MA-remote controller		

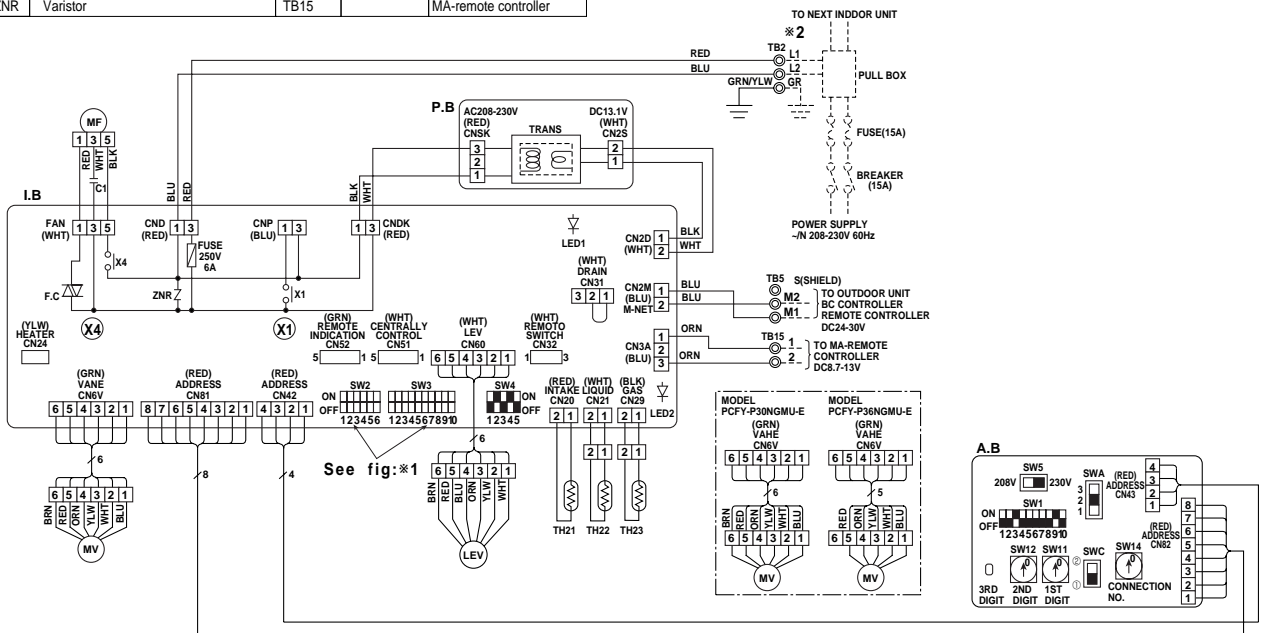

Note

- At servicing for outdoor unit, always follow the wiring diagram of outdoor unit.
- In case of using MA-Remote controller, please connect to TB15. (Remote controller wire is non-polar.)
- In case of using M-NET, please connect to TB5. (Transmission line is non-polar.)
- Symbol [S] of TB5 is the shield wire connection.
- Symbols used in wiring diagram above are: ⊙ : terminal block, □ : connector.
- The setting of the SW2/SW3 dip switches differs in the capacity. For the detail, refer to the fig: *1.
- Please set the switch SW5 according to the power supply voltage. Set SW5 to 230V side when the power supply is 230 volts. When the power supply is 208 volts, set SW5 to 208V side.

<*1>

Models	SW2	SW3
PCFY-P15NGMU-E	ON OFF 1 2 3 4 5 6	ON OFF 1 2 3 4 5 6 7 8 9 10
PCFY-P24NGMU-E	ON OFF 1 2 3 4 5 6	ON OFF 1 2 3 4 5 6 7 8 9 10
PCFY-P30NGMU-E	ON OFF 1 2 3 4 5 6	ON OFF 1 2 3 4 5 6 7 8 9 10
PCFY-P36NGMU-E	ON OFF 1 2 3 4 5 6	ON OFF 1 2 3 4 5 6 7 8 9 10

LED on indoor board for service

Mark	Meaning	Function
LED1	Main power supply	Main power supply (Indoor unit: 208-230V) power on - lamp is lit
LED2	Power supply for MA-Remote controller	Power supply for MA-Remote controller on - lamp is lit

<*2> Use Copper Supply Wire.

6

REFRIGERANT SYSTEM DIAGRAM

PCFY-P15NGMU-E
 PCFY-P24NGMU-E
 PCFY-P30NGMU-E
 PCFY-P36NGMU-E

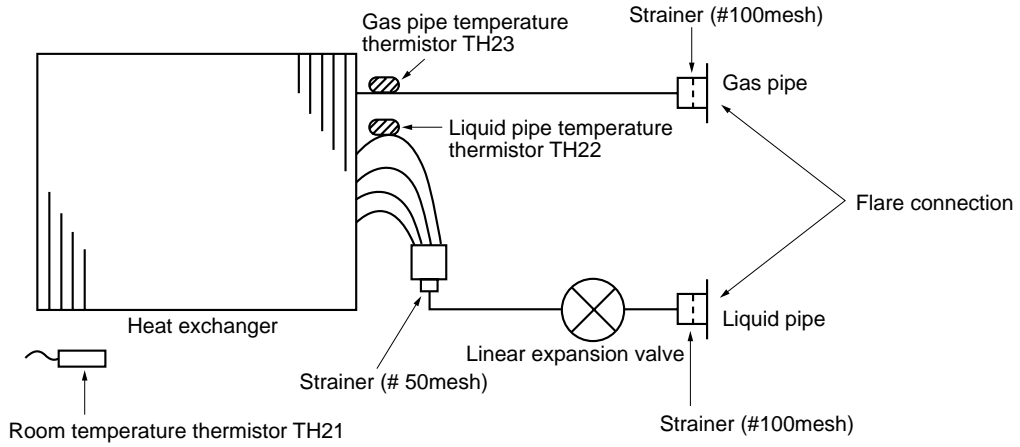

Unit : mm(in.)

Item	Model	PCFY-P15NGMU-E	PCFY-P24/P30NGMU-E	PCFY-P36NGMU-E
Gas pipe		φ12.7(1/2")	φ15.88(5/8")	φ15.88(5/8")/φ19.05(3/4") (compatible)
Liquid pipe		φ6.35(1/4")	φ9.52(3/8")	φ9.52(3/8")

INDOOR UNIT CONTROL

7-1. COOL OPERATION

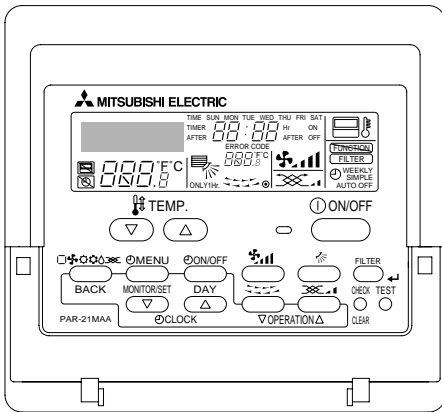

<How to operate>

- ① Press POWER ON/OFF button.
 - ② Press the operation MODE button to display COOL.
 - ③ Press the TEMP. button to set the desired temperature.
- NOTE:** The set temperature changes 2°F when the ∇ or Δ button is pressed one time Cooling 67 to 87°F.

Control modes	Control details	Remarks				
1. Thermoregulating function	1-1. Thermoregulating function (Function to prevent restarting for 3 minutes) <ul style="list-style-type: none"> • Room temperature \geq desired temperature + 2°F ...Thermo ON • Room temperature \leq desired temperature ...Thermo OFF 					
	1-2. Frozen prevention control <p>Detected condition : When the liquid pipe temp. (TH22) is 32°F or less in 16 minutes from compressor start up, anti-freezing control starts and the thermo OFF.</p> <p>Released condition : The timer which prevents reactivating is set for 3 minutes, and anti- freezing control is cancelled when any one of the following conditions is satisfied.</p> <ol style="list-style-type: none"> ① Liquid pipe temp. (TH22) turns to be 50°F or above. ② The condition of the thermo OFF become complete by thermoregulating, etc. ③ The operation modes become mode other than COOL. ④ The operation stops. 					
2. Fan	By the remote controller setting (switch of 4 speeds) <table border="1" style="margin-left: auto; margin-right: auto;"> <thead> <tr> <th>Type</th> <th>Fan speed notch</th> </tr> </thead> <tbody> <tr> <td>4 speeds</td> <td>[Low], [Med2], [Med1], [High]</td> </tr> </tbody> </table>	Type	Fan speed notch	4 speeds	[Low], [Med2], [Med1], [High]	
Type	Fan speed notch					
4 speeds	[Low], [Med2], [Med1], [High]					

To be continued to the next page

From the preceding page

Control modes	Control details	Remarks
<p>3. Drain pump</p>	<p>Drain pump control</p> <ul style="list-style-type: none"> •Always drain pump ON during the COOL and DRY mode operation (Regardless of the thermo ON/ OFF) •When the operation mode has changed from the COOL or DRY to the others (including Stop), OFF the control after the drain pump ON for 3 minutes. <p>Drain sensor function</p> <ul style="list-style-type: none"> • Energize drain sensor at a fixed voltage for a fixed duration. After energizing, compare the drain sensor's temperature to the one before energizing, and judge whether the sensor is in the air or in the water. <p>Basic control system</p> <ul style="list-style-type: none"> • While drain pump is turned on, repeat the following control system and judge whether the sensor is in the air or in the water. <p>Timing of energizing drain sensor</p> <p>ON OFF</p> <p>Stand by for a minute 30 sec. Stand by for a minute 30 sec. Repeat</p> <p>Detect the temperature before energizing (T₀)</p> <p>Detect the temperature after energizing (T₁)</p> <p>Judge whether the sensor is in the air or in the water.</p> <ul style="list-style-type: none"> •Drain sensor temperature rise (Δt) •Temperature of drain sensor before current is applied (T₀) •Temperature of drain sensor after current is applied (T₁) <p>[$\Delta t = T_1 - T_0$]</p>	<p>· Drain sensor Indoor control p.c. board CN31</p>
<p>4. Vane (up/ down vane change)</p>	<p>(1) Initial setting : Start at COOL mode and horizontal vane position.</p> <p>(2) Vane position : Horizontal →Downward A →Downward B →Downward C→Swing</p> <p>(3) Restriction of the downward vane setting When setting the downward vane A, B or C in [Med1], [Med2] or [Low] of the fan speed notch, the vane changes to horizontal position after 1 hour.</p>	<p>· "SET FOR 1 HOUR" appears on the wired remote controller.</p>

7-2. DRY OPERATION

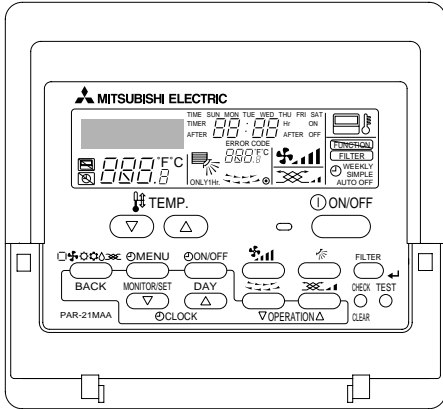

<How to operate>

- ① Press POWER ON/OFF button.
- ② Press the operation MODE button to display DRY.
- ③ Press the TEMP. button to set the desired temperature.

NOTE: The set temperature changes 2°F when the ∇ or Δ button is pressed one time. Dry 67 to 87°F.

Control modes	Control details	Remarks																															
1. Thermoregulating function	<p>1-1. Thermoregulating function (Function to prevent restarting for 3 minutes) Setting the Dry thermo by the thermoregulating signal and the room temperature (TH1). Dry thermo ON Room temperature \geq desired temperature + 2°F Dry thermo OFF Room temperature \leq desired temperature</p> <table border="1"> <thead> <tr> <th rowspan="2">Room temperature</th> <th colspan="2">3 min. passed since starting operation</th> <th rowspan="2">Dry thermo ON time (min)</th> <th rowspan="2">Dry thermo OFF time (min)</th> </tr> <tr> <th>Thermoregulating signal</th> <th>Room temperature (T1)</th> </tr> </thead> <tbody> <tr> <td rowspan="4">Over 64°F</td> <td rowspan="4">ON</td> <td>T1 \geq 83°F</td> <td>9</td> <td>3</td> </tr> <tr> <td>83°F > T1 \geq 79°F</td> <td>7</td> <td>3</td> </tr> <tr> <td>79°F > T1 \geq 75°F</td> <td>5</td> <td>3</td> </tr> <tr> <td>75°F > T1</td> <td>3</td> <td>3</td> </tr> <tr> <td></td> <td>OFF</td> <td>Unconditional</td> <td>3</td> <td>10</td> </tr> <tr> <td>Less than 64°F</td> <td colspan="4">Dry thermo OFF</td> </tr> </tbody> </table>	Room temperature	3 min. passed since starting operation		Dry thermo ON time (min)	Dry thermo OFF time (min)	Thermoregulating signal	Room temperature (T1)	Over 64°F	ON	T1 \geq 83°F	9	3	83°F > T1 \geq 79°F	7	3	79°F > T1 \geq 75°F	5	3	75°F > T1	3	3		OFF	Unconditional	3	10	Less than 64°F	Dry thermo OFF				
	Room temperature		3 min. passed since starting operation				Dry thermo ON time (min)	Dry thermo OFF time (min)																									
Thermoregulating signal		Room temperature (T1)																															
Over 64°F	ON	T1 \geq 83°F	9	3																													
		83°F > T1 \geq 79°F	7	3																													
		79°F > T1 \geq 75°F	5	3																													
		75°F > T1	3	3																													
	OFF	Unconditional	3	10																													
Less than 64°F	Dry thermo OFF																																
	<p>1-2. Frozen prevention control No control function</p>																																
2. Fan	<p>Indoor fan speed depends on the compressor conditions.</p> <table border="1"> <thead> <tr> <th>Dry thermo</th> <th>Fan speed notch</th> </tr> </thead> <tbody> <tr> <td>ON</td> <td>[Low]</td> </tr> <tr> <td>OFF</td> <td>Stop</td> </tr> </tbody> </table> <p>Note: Remote controller setting is not acceptable.</p>	Dry thermo	Fan speed notch	ON	[Low]	OFF	Stop																										
Dry thermo	Fan speed notch																																
ON	[Low]																																
OFF	Stop																																
3. Drain pump	Same control as COOL operation																																
4. Vane (up/ down vane change)	Same control as COOL operation																																

7-3. FAN OPERATION

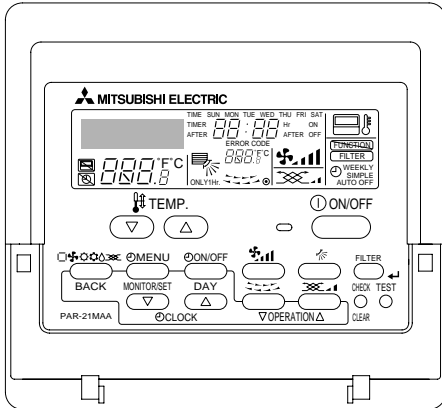

<How to operate>

- ① Press POWER ON/OFF button.
- ② Press the operation MODE button to display FAN.

Control modes	Control details	Remarks				
1. Fan	<p>Set by remote controller.</p> <table border="1"> <thead> <tr> <th>Type</th> <th>Fan speed notch</th> </tr> </thead> <tbody> <tr> <td>4 speeds</td> <td>[Low], [Med2], [Med1], [High]</td> </tr> </tbody> </table>	Type	Fan speed notch	4 speeds	[Low], [Med2], [Med1], [High]	
Type	Fan speed notch					
4 speeds	[Low], [Med2], [Med1], [High]					
2. Drain pump	<p>2-1. Drain pump control The drain pump turns ON for the specified amount of time when any of the following conditions is satisfied:</p> <ol style="list-style-type: none"> ① ON for 3 minutes after the operation mode is switched from COOL or DRY to another operation mode (FAN). ② ON for 6 minutes after the drain sensor is determined to be submerged using the liquid level detection method given below. ③ ON for 6 minutes after indoor piping (liquid piping) temperature – indoor intake temperature $\leq -18^{\circ}\text{F}$, AND the drain sensor input is at the short or open level. (If condition ② or ③ is still being met after the drain pump has been turned ON for 6 minutes, the drain pump is kept ON for a further 6 minutes.) <p>2-2. Liquid level detection method The liquid level is detected by determining whether or not the drain sensor is submerged, based on the temperature rise after self-heating the sensor. This process is performed if any of the following conditions is satisfied:</p> <ol style="list-style-type: none"> ① Drain pump is ON. ② Indoor piping (liquid piping) temperature – indoor intake temperature $\leq -18^{\circ}\text{F}$ ③ Indoor piping (liquid piping) temperature or indoor intake temperature is at the short or open level temperature. ④ Every hour after the drain pump is switched from ON to OFF. 					
3. Vane (up/ down vane change)	Same as the control performed during the COOL operation, but with no restriction on the vane's downward blow setting					

7-4. HEAT OPERATION

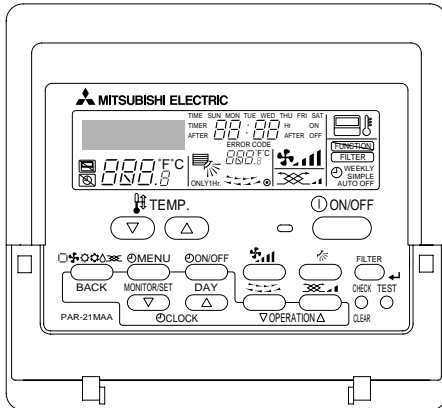

<How to operate>

- ① Press POWER ON/OFF button.
- ② Press the operation MODE button to display HEAT.
- ③ Press the TEMP. button to set the desired temperature.

NOTE: The set temperature changes 2°F when the or button is pressed one time. Heating 63 to 83°F.

<Display in HEAT operation>

[DEFROST]

The [DEFROST] symbol is only displayed during the defrost operation.

[STANDBY]

The [STANDBY] symbol is only displayed from the time the heating operation starts until the heated air begins to blow.

Control modes	Control details	Remarks
1. Thermoregulating function	<p>1-1. Thermoregulating function (Function to prevent restarting for 3 minutes)</p> <ul style="list-style-type: none"> • Room temperature \leq desired temperature -2°F ...Thermo ON • Room temperature \geq desired temperature ...Thermo OFF 	
2. Fan	<p>Controlled by the remote controller (4-speed) Priority is given to below-mentioned controlled mode</p> <p>2-1. Hot adjuster mode 2-2. Preheating exclusion mode 2-3. Thermo OFF mode (When the compressor off by the thermoregulating) 2-4. Cool air prevention mode (Defrosting mode) 2-5. Capacity increasing mode</p> <p>2-1. Hot adjuster mode The fan controller becomes the hot adjuster mode for the following conditions.</p> <ol style="list-style-type: none"> ① When starting the HEAT operation ② When the thermoregulating function changes from OFF to ON. ③ When releasing the HEAT defrosting operation <p>A: HOT adjuster mode start B: 5 min after the condition A or the indoor liquid pipe temperature turned 95°F or more C: 2 min after the condition A (Terminating the hot adjuster mode)</p>	<p>*1 "STAND BY" will be displayed during the hot adjuster mode.</p>
	<p>2-2. Preheating exclusion mode When the condition changes, the auxiliary heater ON to OFF (thermoregulating or operation stop, etc), the indoor fan operates in [Low] mode for 1 minute.</p>	<p>• This control is same for the model without auxiliary heater.</p>

To be continued to the next page.

From the preceding page

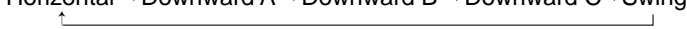
Control modes	Control details	Remarks
2. Fan	2-3. Thermo OFF mode When the thermoregulating function changes to OFF, the indoor fan operates in [Extra low].	
	2-4. Heat defrosting mode The indoor fan stops.	
3. Drain pump	No drain pump operation However, when the control changes from COOL or DRY operation, the drain pump operates for 3 minutes.	
4. Vane control (Up/ down vane change)	(1) Initial setting : OFF → HEAT...[last setting] When changing the mode from exception of HEAT to HEAT operation. ...[Downward C] (2) Vane position : Horizontal →Downward A →Downward B →Downward C →Swing  (3) Restriction of vane position The vane is horizontally fixed for the following modes. (The control by the remote controller is temporally invalidated and it is controlled by the unit.) <ul style="list-style-type: none"> •Thermo OFF •Hot adjuster [Extra low] mode •Heat defrost mode 	

7-5. AUTO OPERATION [AUTOMATIC COOL/HEAT CHANGE OVER OPERATION]

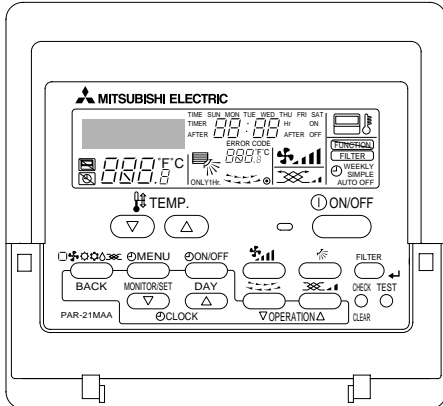

<How to operate>

- ① Press POWER ON/OFF button.
 - ② Press the operation MODE button to display AUTO.
 - ③ Press the TEMP. button to set the desired temperature.
- NOTE:** The set temperature changes 2°F when the or button is pressed one time. Automatic 67 to 83°F.
“AUTO” works to change by itself the operation mode either to cooling or heating to the room temperature.

Control modes	Control details	Remarks
1. Initial value of operation mode	HEAT mode for room temperature < Desired temperature COOL mode for room temperature \geq Desired temperature	
2. Mode change	(1) HEAT mode \rightarrow COOL mode Room temperature \geq Desired temperature + 3°F. or 3 min. has passed (2) COOL mode \rightarrow HEAT mode Room temperature \leq Desired temperature - 3°F. or 3 min. has passed	
3. COOL mode	Same control as cool operation	
4. HEAT mode	Same control as heat operation	

7-6. WHEN UNIT IS STOPPED

Control modes	Control details	Remarks
1. Drain pump	<p>1-1. Drain pump control</p> <p>The drain pump turns ON for the specified amount of time when any of the following conditions is satisfied (regardless of whether the compressor is ON or OFF)</p> <ol style="list-style-type: none"> ① ON for 3 minutes after the operation mode is switched from COOL or DRY to another operation mode (HEAT mode). ② ON for 6 minutes after the drain sensor is determined to be submerged using the liquid level detection method given below. ③ ON for 6 minutes after indoor piping (liquid piping) temperature – indoor intake temperature $\leq 14^\circ\text{F}$, AND the drain sensor input is at the short or open level. (If condition ② or ③ is still being met after the drain pump has been turned ON for 6 minutes, the drain pump is kept ON for a further 6 minutes.) <p>1-2. Liquid level detection method</p> <p>The liquid level is detected by determining whether or not the drain sensor is submerged, based on the amount the temperature rises after self-heating the sensor. This process is performed if any of the following conditions is satisfied:</p> <ol style="list-style-type: none"> ① Drain pump is ON. ② Indoor piping (liquid piping) temperature – indoor intake temperature $\leq 14^\circ\text{F}$ (except during defrosting) ③ Indoor piping (liquid piping) temperature or indoor intake temperature is at the short or open level temperature. ④ Every hour after the drain pump is switched from ON to OFF. 	

8-1. HOW TO CHECK THE PARTS

PCFY-P15NGMU-E PCFY-P24NGMU-E PCFY-P30NGMU-E PCFY-P36NGMU-E

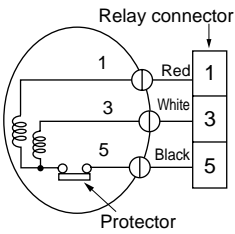
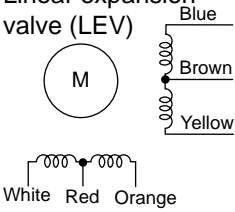
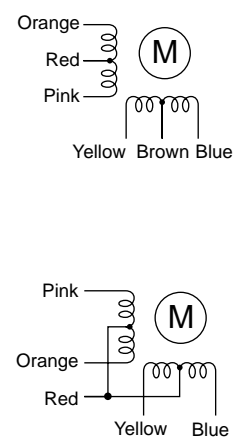
Parts name	Check points																									
Room temperature thermistor (TH21) Liquid pipe temperature thermistor (TH22) Gas pipe temperature thermistor (TH23)	Disconnect the connector then measure the resistance using a tester. (Surrounding temperature 50°F~86°F) <table border="1" style="margin-left: 20px;"> <thead> <tr> <th>Normal</th> <th>Abnormal</th> </tr> </thead> <tbody> <tr> <td>4.3kΩ~9.6kΩ</td> <td>Open or short</td> </tr> </tbody> </table> Refer to the next page for the details.	Normal	Abnormal	4.3kΩ~9.6kΩ	Open or short																					
Normal	Abnormal																									
4.3kΩ~9.6kΩ	Open or short																									
Fan motor (MF) 	Measure the resistance between the terminals using a tester. <table border="1" style="margin-left: 20px;"> <thead> <tr> <th rowspan="3">Motor terminal or Relay connector</th> <th colspan="4">Normal</th> <th rowspan="3">Abnormal</th> </tr> <tr> <th colspan="4">PCFY-</th> </tr> <tr> <th>P15NGMU-E</th> <th>P24NGMU-E</th> <th>P30NGMU-E</th> <th>P36NGMU-E</th> </tr> </thead> <tbody> <tr> <td>Red-Black</td> <td>70.6Ω</td> <td>45.0Ω</td> <td>41.1Ω</td> <td>20.4Ω</td> <td rowspan="2">Open or short</td> </tr> <tr> <td>White-Black</td> <td>69.6Ω</td> <td>44.8Ω</td> <td>54.3Ω</td> <td>20.7Ω</td> </tr> </tbody> </table>	Motor terminal or Relay connector	Normal				Abnormal	PCFY-				P15NGMU-E	P24NGMU-E	P30NGMU-E	P36NGMU-E	Red-Black	70.6Ω	45.0Ω	41.1Ω	20.4Ω	Open or short	White-Black	69.6Ω	44.8Ω	54.3Ω	20.7Ω
Motor terminal or Relay connector	Normal				Abnormal																					
	PCFY-																									
	P15NGMU-E	P24NGMU-E	P30NGMU-E	P36NGMU-E																						
Red-Black	70.6Ω	45.0Ω	41.1Ω	20.4Ω	Open or short																					
White-Black	69.6Ω	44.8Ω	54.3Ω	20.7Ω																						
Linear expansion valve (LEV) 	Disconnect the connector then measure the resistance valve using a tester. <table border="1" style="margin-left: 20px;"> <thead> <tr> <th colspan="4">Normal</th> <th rowspan="3">Abnormal</th> </tr> <tr> <td>White-Red</td> <td>Yellow-Brown</td> <td>Orange-Red</td> <td>Blue-Brown</td> </tr> <tr> <td colspan="4">150kΩ ±10%</td> </tr> </thead> <tbody> <tr> <td colspan="4"></td> <td>Open or short</td> </tr> </tbody> </table> Refer to the next page for the details.	Normal				Abnormal	White-Red	Yellow-Brown	Orange-Red	Blue-Brown	150kΩ ±10%								Open or short							
Normal				Abnormal																						
White-Red	Yellow-Brown	Orange-Red	Blue-Brown																							
150kΩ ±10%																										
				Open or short																						
Vane motor (MV) 	Measure the resistance between the terminals using a tester. (Surrounding temperature 68°F~86°F) <table border="1" style="margin-left: 20px;"> <thead> <tr> <th rowspan="2">Connector</th> <th colspan="2">Normal</th> <th rowspan="2">Abnormal</th> </tr> <tr> <th>PCFY-P15NGMU-E</th> <th>PCFY-P24NGMU-E</th> </tr> </thead> <tbody> <tr> <td>Brown — Yellow</td> <td rowspan="3">186~214Ω</td> <td rowspan="3">140~160Ω</td> <td rowspan="4">Open or short</td> </tr> <tr> <td>Brown — Blue</td> </tr> <tr> <td>Red — Orange</td> </tr> <tr> <td>Red — Pink</td> </tr> </tbody> </table> <table border="1" style="margin-left: 20px;"> <thead> <tr> <th rowspan="2">Connector</th> <th colspan="2">Normal</th> <th rowspan="2">Abnormal</th> </tr> <tr> <th colspan="2">PCFY-P30NGMU-E, PCFY-P36NGMU-E</th> </tr> </thead> <tbody> <tr> <td>Red — Blue</td> <td rowspan="4">140~160Ω</td> <td rowspan="4">Open or short</td> </tr> <tr> <td>Red — Yellow</td> </tr> <tr> <td>Red — Pink</td> </tr> <tr> <td>Red — Orange</td> </tr> </tbody> </table>	Connector	Normal		Abnormal	PCFY-P15NGMU-E	PCFY-P24NGMU-E	Brown — Yellow	186~214Ω	140~160Ω	Open or short	Brown — Blue	Red — Orange	Red — Pink	Connector	Normal		Abnormal	PCFY-P30NGMU-E, PCFY-P36NGMU-E		Red — Blue	140~160Ω	Open or short	Red — Yellow	Red — Pink	Red — Orange
Connector	Normal		Abnormal																							
	PCFY-P15NGMU-E	PCFY-P24NGMU-E																								
Brown — Yellow	186~214Ω	140~160Ω	Open or short																							
Brown — Blue																										
Red — Orange																										
Red — Pink																										
Connector	Normal		Abnormal																							
	PCFY-P30NGMU-E, PCFY-P36NGMU-E																									
Red — Blue	140~160Ω	Open or short																								
Red — Yellow																										
Red — Pink																										
Red — Orange																										

<Thermistor characteristic graph>

Thermistor for lower temperature

- Thermistor <Room temperature detection> (TH21)
- Thermistor <Liquid pipe temperature detection> (TH22)
- Thermistor <Gas pipe temperature detection> (TH23)

Thermistor $R_0=15k\Omega \pm 3\%$
 Fixed number of $B=3480K \pm 2\%$

$$R_t = 15 \exp \left\{ 3480 \left(\frac{1}{273 + (t-32)/1.8} - \frac{1}{273} \right) \right\}$$

30°F	15.8kΩ
50°F	9.6kΩ
70°F	6.0kΩ
80°F	4.8kΩ
90°F	3.9kΩ
100°F	3.2kΩ

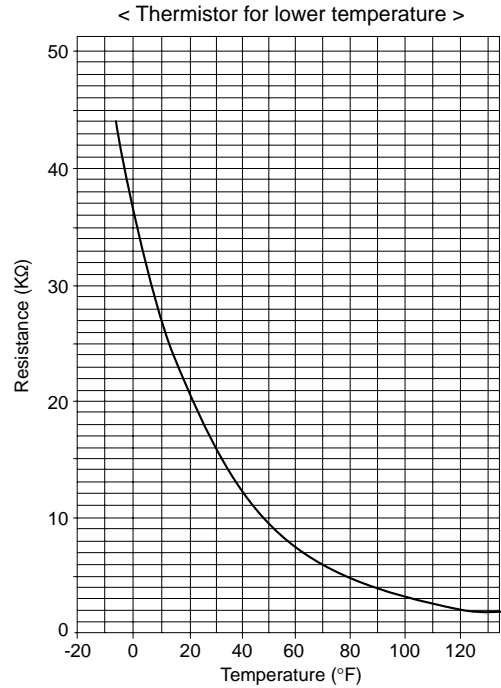

Linear expansion valve

① Operation summary of the linear expansion valve

- Linear expansion valve open/close through stepping motor after receiving the pulse signal from the indoor controller board.
- Valve opening can be changed in proportion to the number of pulse signal.

<Connection between the indoor controller board and the linear expansion valve>

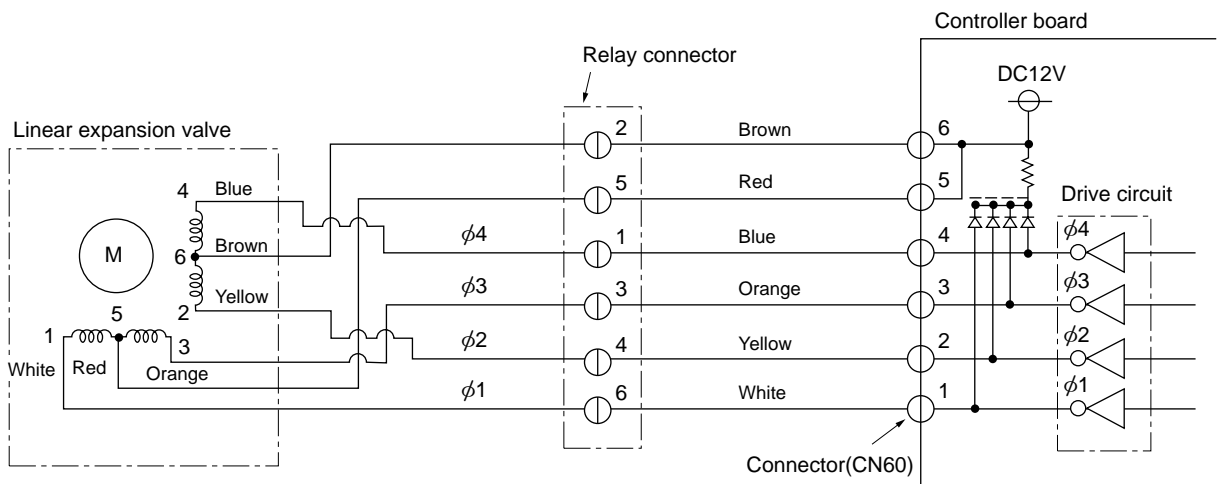

Note : Since the number of the connector at the controller board side and the relay connector are different, follow the color of the lead wire.

<Output pulse signal and the valve operation>

Output (Phase) number	Output			
	1	2	3	4
$\phi 1$	ON	OFF	OFF	ON
$\phi 2$	ON	ON	OFF	OFF
$\phi 3$	OFF	ON	ON	OFF
$\phi 4$	OFF	OFF	ON	ON

Closing a valve : 1 → 2 → 3 → 4 → 1
 Opening a valve : 4 → 3 → 2 → 1 → 4
 The output pulse shift as above order.

- * 1. When linear expansion valve operation stops, all output phase become OFF.
- 2. At phase interruption or when phase does not shift in order, the motor does not rotate smoothly and motor will lock and vibrate.

② Linear expansion valve operation

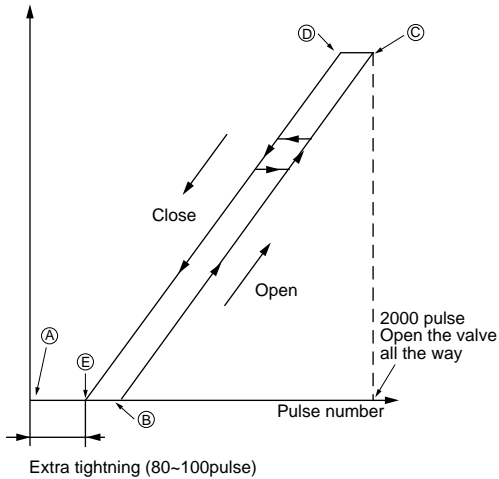

- * When the switch is turned on, 2200 pulse closing valve signal will be send till it goes to ① point in order to define the valve position.

When the valve move smoothly, there is no noise or vibration occur from the linear expansion valve : however, when the pulse number moves from ⑤ to ① or when the valve is locked, more noise can be heard than normal situation.









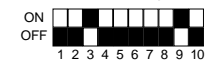
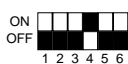

- * Noise can be detected by placing the ear against the screw driver handle while putting the screw driver to the linear expansion valve.

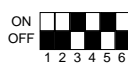
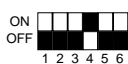
③ Trouble shooting

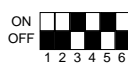
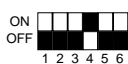

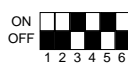

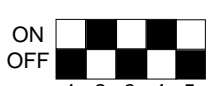



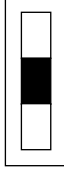
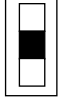

Symptom	Check points	Countermeasures
Operation circuit failure of the micro processor	Disconnect the connector on the controller board, then connect LED for checking. Pulse signal will be sent out for 10 seconds as soon as the main switch is turn on. If there is LED with lights on or lights off, it means the operation circuit is abnormal.	Exchange the indoor controller board at drive circuit failure.
Linear expansion valve mechanism is locked	Motor will idle and make ticking noise when motor is operated while the linear expansion valve is locked. This ticking sound is the sign of the abnormality.	Exchange the linear expansion valve.
Short or breakage of the motor coil of the linear expansion valve	Measure the resistance between the each coil (red-white, red-orange, brown-yellow, brown-blue) using a tester. It is normal if the resistance is in the range of $150\Omega \pm 10\%$	Exchange the linear expansion valve.
Valve doesn't close completely (thermistor leaking).	To check the linear expansion valve, operate the indoor unit in fan mode and at the same time operate other indoor units in cooling mode, then check the pipe temperature <liquid pipe temperature> of the indoor unit by the outdoor multi controller board operation monitor. During fan operation, linear expansion valve is closed completely and if there are some leakage, detecting temperature of the thermistor will go lower. If the detected temperature is much lower than the temperature indicated in the remote controller, it means the valve is not closed all the way. It is not necessary to exchange the linear expansion valve, if the leakage is small and not making any trouble. 	If large amount of thermistor is leaked, exchange the linear expansion valve.
Wrong connection of the connector or contact failure	Check the color of lead wire and missing terminal of the connector.	Disconnect the connector at the controller board, then check the continuity.

8-2. FUNCTION OF DIP SWITCH

PCFY-P15NGMU-E PCFY-P24NGMU-E PCFY-P30NGMU-E PCFY-P36NGMU-E

Switch	Pole	Function	Operation by switch		Remarks																		
			ON	OFF																			
SW1 Mode Selection	1	Room temperature thermistor position	Built-in remote controller	Indoor unit	<div style="border: 1px solid black; padding: 5px; display: inline-block;">Address board</div> <At delivery>  NOTE: ※1 At Heating mode, fan operating. ※2 At Heater mode, operating heat thermostat ON. ※3 SW1-7=OFF, SW1-8=ON →Setting air flow. SW1-7=ON, SW1-8=ON →Indoor fan stop.																		
	2	Filter clogging detection	Provided	Not provided																			
	3	Filter cleaning sign	2500hr	100hr																			
	4	Air intake	Effective	Not effective																			
	5	Remote indication switching	Thermostat ON signal indication	Fan output indication																			
	6	Humidifier control	Always operated while the heating mode ※1	Operation depends on the condition ※2																			
	7	Air flow set in case of	Fix to LOW ※3	Fix to EXTRA LOW ※3																			
	8	heat thermostat OFF	Depends on setting remote controller ※3	Depends on SW1-7																			
	9	Auto reset function	Effective	Not effective																			
	10	Power resource ON/OFF	Effective	Not effective																			
SW2 Capacity code setting	1~6	<table border="1" style="width: 100%; text-align: center;"> <thead> <tr> <th>Model name</th> <th>SW2</th> <th>Model name</th> <th>SW2</th> <th>Model name</th> <th>SW2</th> </tr> </thead> <tbody> <tr> <td>PCFY-P15NGMU-E</td> <td></td> <td>PCFY-P24NGMU-E</td> <td></td> <td>PCFY-P30NGMU-E</td> <td></td> </tr> <tr> <td>PCFY-P36NGMU-E</td> <td></td> <td></td> <td></td> <td></td> <td></td> </tr> </tbody> </table>			Model name	SW2	Model name	SW2	Model name	SW2	PCFY-P15NGMU-E		PCFY-P24NGMU-E		PCFY-P30NGMU-E		PCFY-P36NGMU-E						<div style="border: 1px solid black; padding: 5px; display: inline-block;">Indoor controller board</div> Set while the unit is off. <At delivery> Set for each capacity.
		Model name	SW2	Model name	SW2	Model name	SW2																
PCFY-P15NGMU-E		PCFY-P24NGMU-E		PCFY-P30NGMU-E																			
PCFY-P36NGMU-E																							
SW3 Function Selection	1	Heat pump/Cool only	Cooling only	Heat pump	<div style="border: 1px solid black; padding: 5px; display: inline-block;">Indoor controller board</div> Set while the unit is off. <At delivery>  NOTE: ※4 At cooling mode, each angle can be used only 1 hour. ※5 SW3-9 setting P15 = ON P24/P30/P36 = OFF																		
	2	Louver	Available	Not available																			
	3	Vane	Available	Not available																			
	4	Vane swing function	Available	Not available																			
	5	Vane horizontal angle	Second setting	First setting																			
	6	Vane cooling limit angle setting ※4	Horizontal angle	Down B,C																			
	7	Indoor linear expansion valve opening	Effective	Not effective																			
	8	Heater 4 degrees up	Not effective	Effective																			
	9	Target Superheat setting ※5	9 degrees	6 degrees																			
	10	Target Subcool setting	15 degrees	10 degrees																			
SW4 Unit Selection	1~4				<div style="border: 1px solid black; padding: 5px; display: inline-block;">Indoor controller board</div> Set while the unit is off. <At delivery> 																		

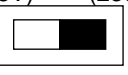

Switch		Operation by switch	Remarks
SWA Set the ceiling height	1~3	<p>※ Ceiling height can be changed depends on SW A setting.</p> <p>(High) 3 (Standard) 2 (Low) 1</p> 	<p>Address board</p> <p><At delivery></p> 
SWC Option	2	<p>Option (Standard)</p>  <p>When the optional high performance filter elements (filter casement) is attached to the unit, be sure to set switch to the option side in order to prevent the airflow reducing.</p>	<p>Address board</p> <p><At delivery></p> <p>Option</p> 
SW11 1st digit address setting SW12 2nd digit address setting	Rotary switch	  <p>Address setting should be done when M-NET remote controller is being used.</p>	<p>Address board</p> <p>Address can be set while the unit is stopped.</p> <p><At delivery></p>  
SW14 Connection No. setting	Rotary switch	 <p>This is the switch to be used when the indoor unit is operated with R2 series outdoor unit as a set.</p>	<p>Address board</p> <p><At delivery></p> 
SW5 Voltage selection	2	<p>220V (208V) 240V (230V)</p>  <p>If the unit is used at the 230V area, set the voltage to 230V. If the unit is used at the 208V, set the voltage to 208V.</p>	<p>Address board</p> <p><At delivery></p> <p>220V (208V) 240V (230V)</p> 

8-3. TEST POINT DIAGRAM

8-3-1. Indoor controller board

PCFY-P15NGMU-E PCFY-P24NGMU-E

PCFY-P30NGMU-E PCFY-P36NGMU-E

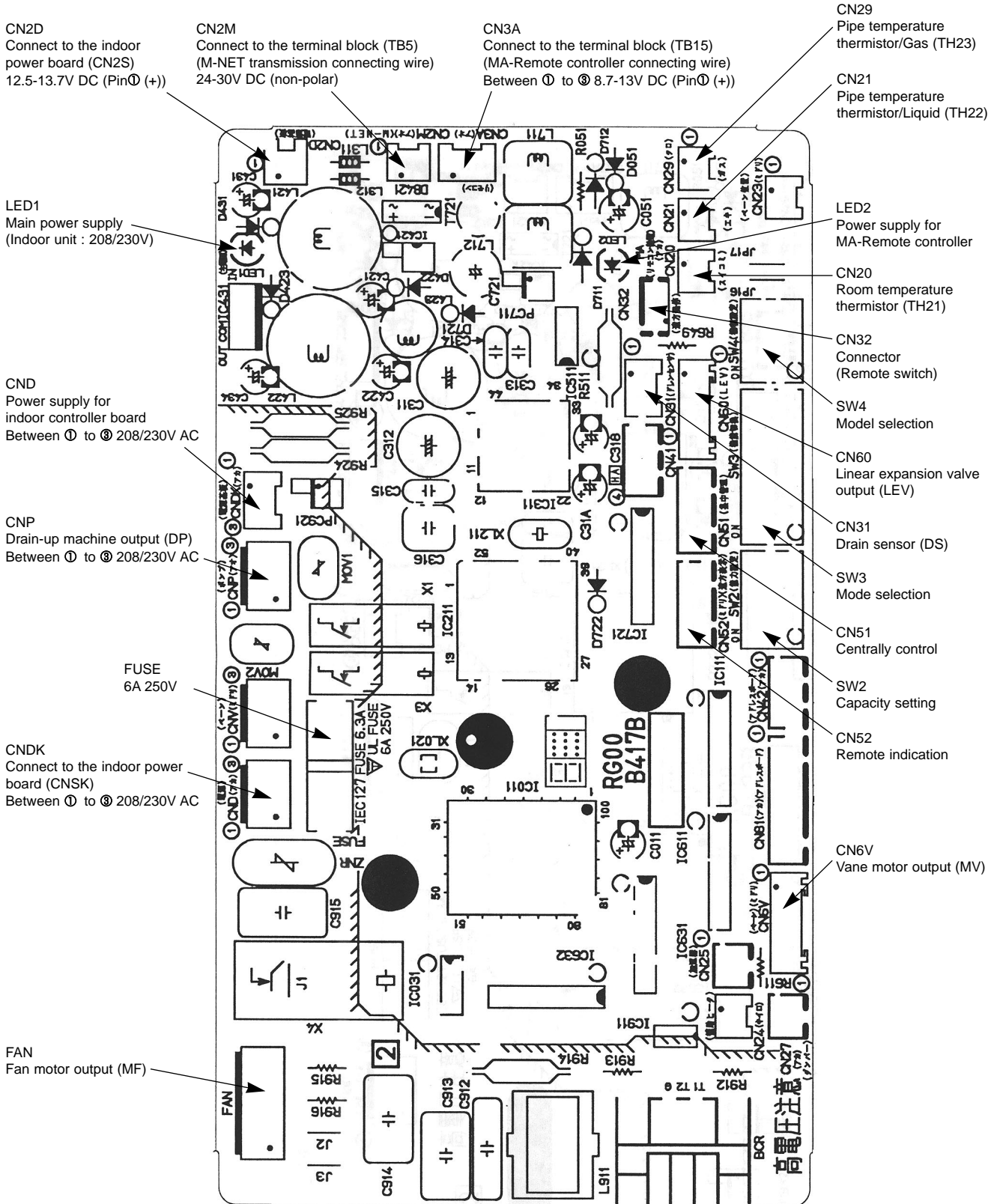

8-3-2. Indoor power board
 PCFY-P15NGMU-E
 PCFY-P24NGMU-E
 PCFY-P30NGMU-E
 PCFY-P36NGMU-E

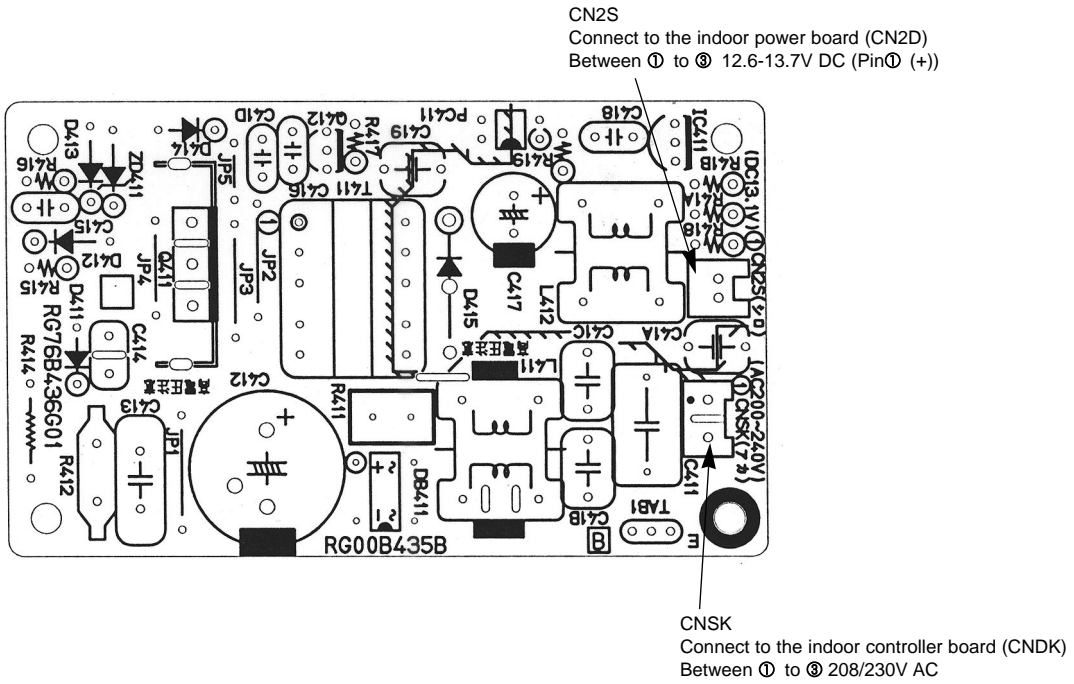

INDOOR UNIT :

PCFY-P15NGMU-E PCFY-P24NGMU-E PCFY-P30NGMU-E PCFY-P36NGMU-E

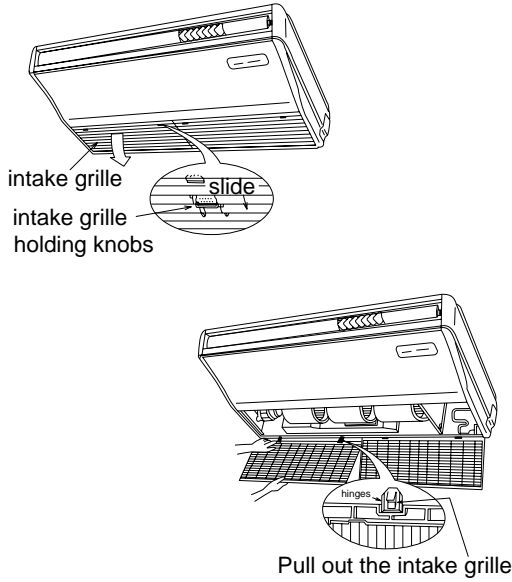
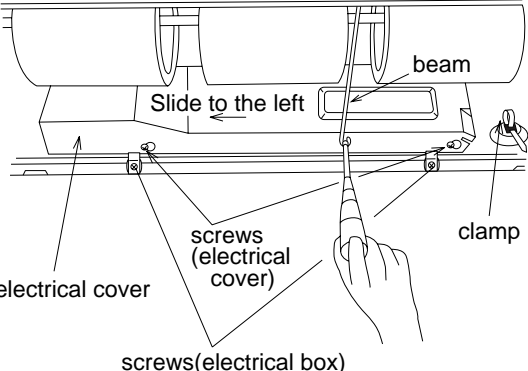
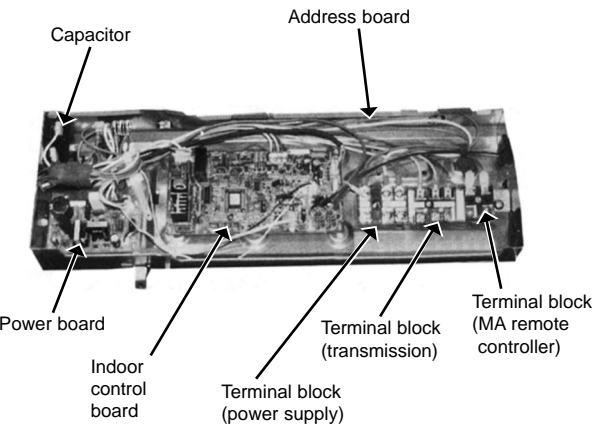
OPERATING PROCEDURE	PHOTOS & ILLUSTRATIONS
<p>1. Removing the air intake grille</p> <ol style="list-style-type: none"> (1) Slide the intake grille holding knobs at backward to open the intake grille. (2) When the intake grille opens, push the stoppers on the rear hinges (at two locations) to pull out the intake grille. 	<p>Figure 1</p> 
<p>2. Removing the electrical box</p> <ol style="list-style-type: none"> (1) Remove the air intake grille. (2) Remove the screw from the beam and remove the beam. (3) Remove the screws from the electrical cover, and remove the electrical cover. (4) Disconnect the following wires from the indoor control board. <ul style="list-style-type: none"> • Fan motor : FAN • Vane motor : CN6V • Linear expansion valve : CN60 • Room temperature thermistor : CN20 • Liquid pipe temperature thermistor : CN21 • Gas pipe temperature thermistor : CN29 (5) Remove the screws from the electrical box and pull out the electrical box. <p><Electrical parts in the electrical box></p> <ul style="list-style-type: none"> Terminal block (for power supply) Terminal block (for transmission) Terminal block (for MA remote controller) Indoor control board Address board Power board Capacitor 	<p>Figure 2</p>  <p>Photo 1</p> 

OPERATING PROCEDURE

PHOTOS & ILLUSTRATIONS

3. Removing the fan motor

- (1) Remove the intake grille.
- (2) Disconnect the fan motor connector.
- (3) Remove the screw for removing the motor support at both left and right side.
- (4) Loosen the set screws at the fan motor side of the connecting joint.
- (5) Slide the fan motor to the left side and pull it out.

Photo 2

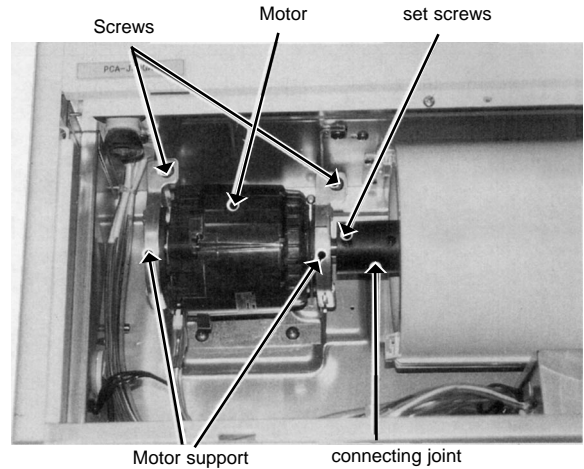

4. Removing the sirocco fan

- (1) Remove the air intake grille.
- (2) Remove 1 beam.
- (3) Remove the lower casing while pressing the stoppers at upper side of the casing.
- (4) Loosen the set screws at the connecting joint.
- (5) Remove the sirocco fan and shaft together by sliding the shaft to the left.

(Note)

Make sure that the upper side casing is snapped to the fan plate securely with catch.

Photo 3

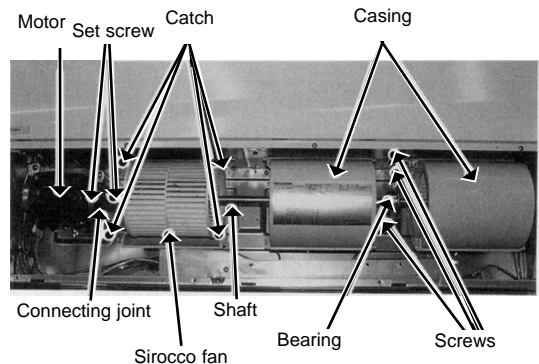

5. Removing the side panel

- (1) Remove the air intake grille.
- (2) Remove the screw from the side panel, and remove the side panel by sliding the panel to the front.

Figure 3

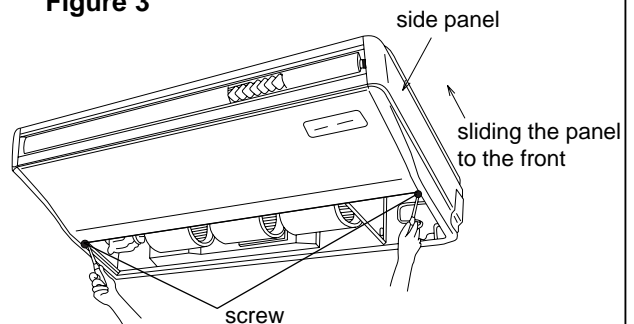

OPERATING PROCEDURE

6. Removing the vane motor

- (1) Remove the intake grille.
- (2) Remove the left side panel.
- (3) Remove the relay connector of vane motor.
- (4) Remove the electrical box.
- (5) Remove the screws of vane motor, then remove vane motor.

(Note)

Connect the lead wires and connectors properly and place them in the proper position so that the wires are not pinched by other parts.

7. Removing the pipe temperature thermistor

- (1) Remove the air intake grille.
- (2) Remove the right side panel.
- (3) Remove the relay connector of the pipe temperature thermistor.
- (4) Remove the screw, and remove the check panel.
- (5) Extract the pipe temperature thermistor from the holder.

<Caution for the installation>

There is a possibility for the short circuit when connector gets wet by water through the thermistor lead wire.

Therefore, lead wire of the pipe temperature thermistor should be trapped as shown in photo 6.

- (6) Gas pipe temperature thermistor is inserted to the holder of the gas pipe (Header)

Figure 4

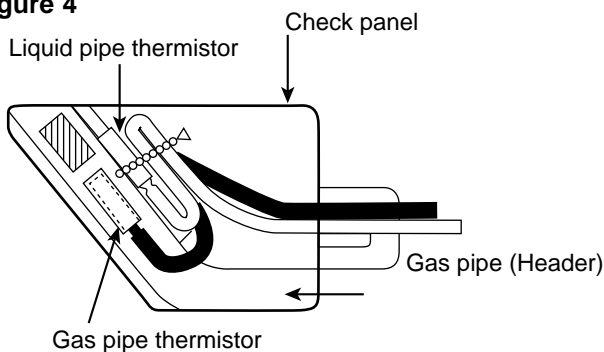

PHOTOS & ILLUSTRATIONS

Photo 4

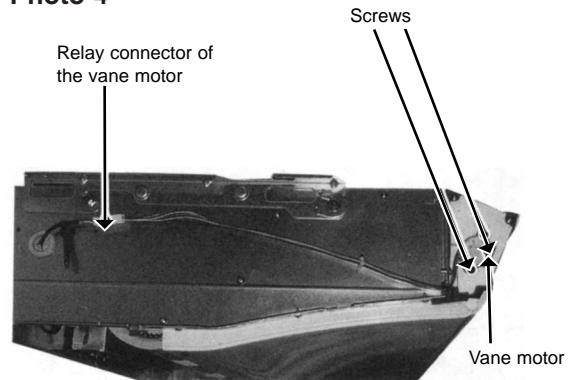

Photo 5

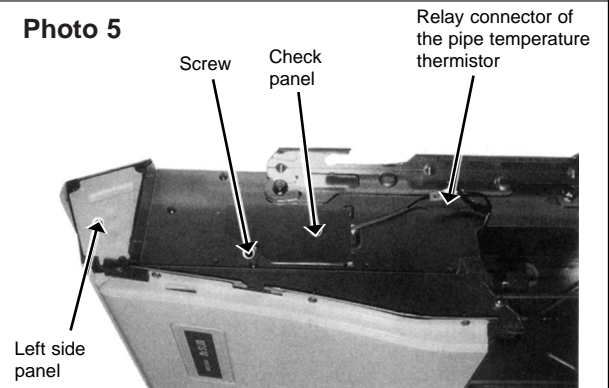
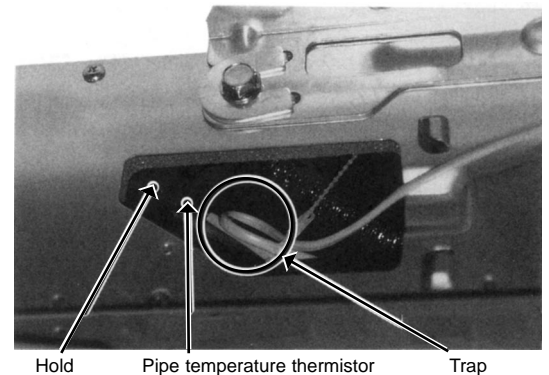

Photo 6



8. Removing the under panel

- (1) Remove the air intake grille.
- (2) Remove the beam.
- (3) Remove the side panel (right and left).
- (4) Unscrew the screws of the under panel, then remove the lower panel.

※ Weight of the lower panel : Approx. 2kg.

Photo 7

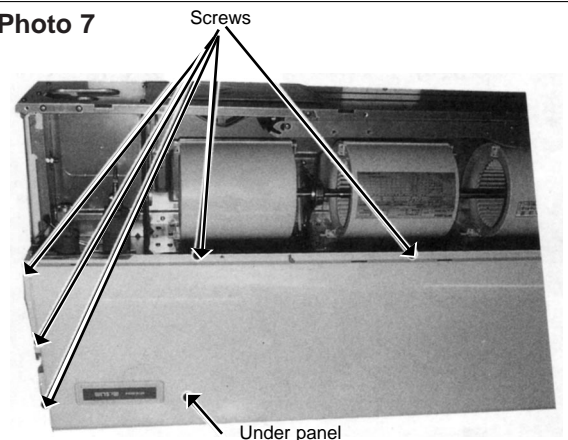

OPERATING PROCEDURE

PHOTOS & ILLUSTRATIONS

9. Removing the drain pan

- (1) Remove the air intake grille.
- (2) Remove the beam.
- (3) Remove the side panel (right and left).
- (4) Remove the under panel. Remove the screws of the right and left side drain pan.
- (5) Remove the insulation in centre of the drain pan, and after removing the screw, remove the drain pan.

(Note)

Please note that there might be drain left in the drain pan when you remove the drain pan.

Photo 8

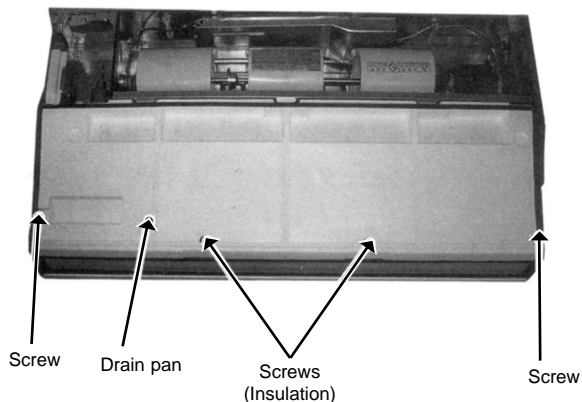

10. Removing the guide vane

- (1) Remove the intake grille.
- (2) Remove the beam.
- (3) Remove the side panel (right and left).
- (4) Remove the under panel.
- (5) Remove the drain pan.
- (6) Remove the screw from the guide vane, then remove the guide vane.

Photo 9

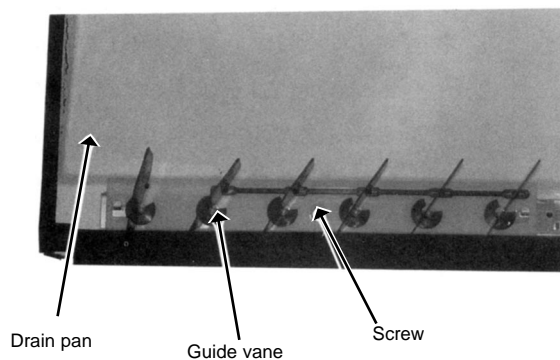

11. Removing the Auto vane

- (1) Remove the intake grille.
- (2) Remove the left side panel.
- (3) Remove the left side box.
- (4) Remove the under panel.
- (5) Remove the screw from the auto vane.
- (6) Slide the auto vane to the right side and pull the auto vane out.

Photo 10

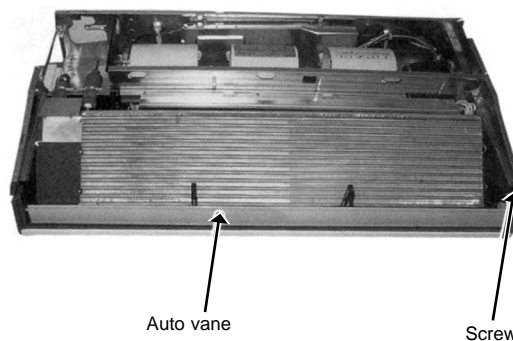

10

PARTS LIST (non-RoHS compliant)

ELECTRICAL PARTS

PCFY-P15NGMU-E

PCFY-P24NGMU-E

PCFY-P30NGMU-E

PCFY-P36NGMU-E

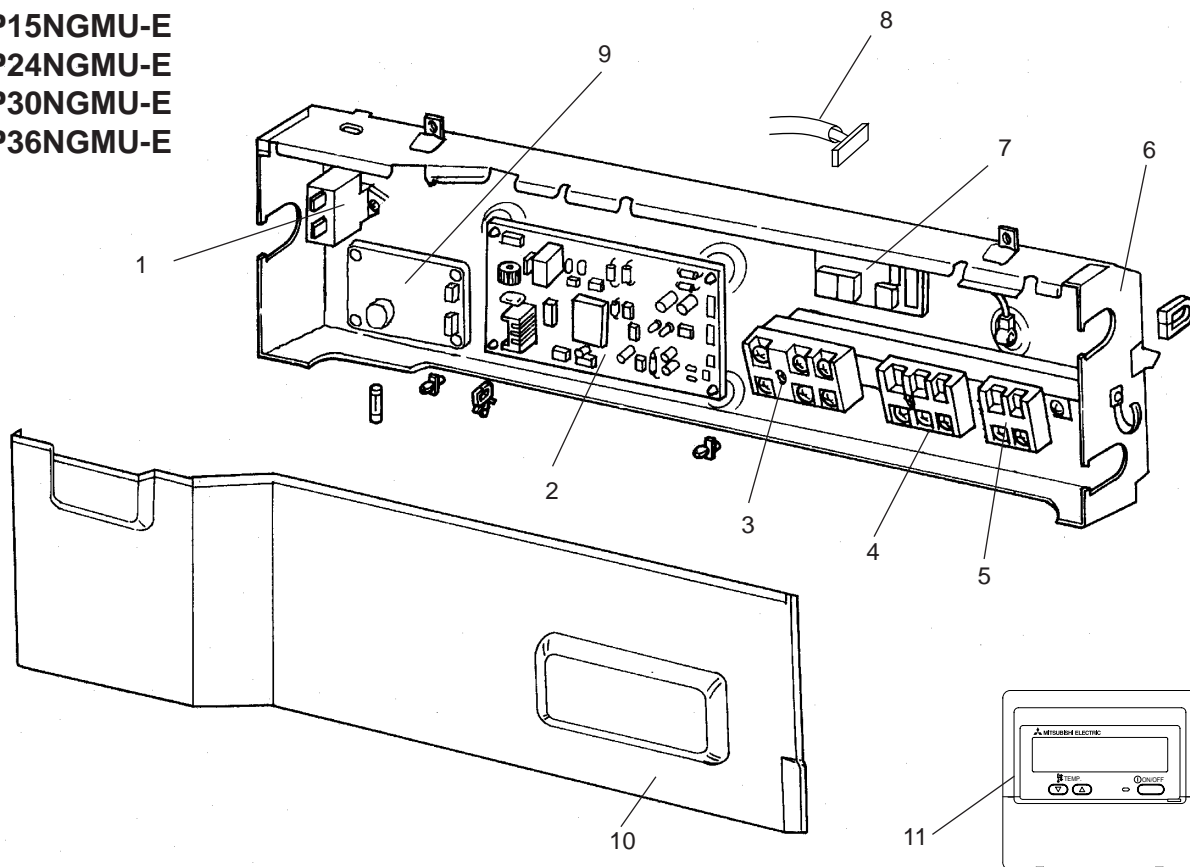

No.	Parts No.	Parts Name	Specifications	Q'ty/set				Remarks (Drawing No.)	Wiring Diagram Symbol	Recom- mended Q'ty	Price	
				PCFY-P • NGMU-E							Unit	Amount
				15	24	30	36					
1	T7W E10 255	CAPACITOR	3 μ F 440V	1					C1			
	T7W E12 255	CAPACITOR	4 μ F 440V		1				C1			
	T7W E07 255	CAPACITOR	5 μ F 440V			1			C1			
	R01 E03 255	CAPACITOR	7 μ F 440V				1		C1			
2	T7W E42 310	INDOOR CONTROLLER BOARD		1	1	1	1		I.B			
3	T7W E11 716	TERMINAL BLOCK	3P(L1,L2,GR)	1	1	1	1		TB2			
4	T7W E17 716	TERMINAL BLOCK	3P(M1,M2,S)	1	1	1	1		TB5			
5	R01 556 246	TERMINAL BLOCK	2P(1,2)	1	1	1	1		TB15			
6	—	CONTROL BOX		1	1	1	1	(BG00N015G31)				
7	T7W E00 294	ADDRESS BOARD		1	1	1	1		A.B			
8	R01 05A 304	ADDRESS CABLE		1	1	1	1					
9	R01 E02 313	POWER BOARD		1	1	1	1		P.B			
10	—	BOX COVER		1				(BG02A804G20)				
	—	BOX COVER			1		1	(BG02A804G21)				
	—	BOX COVER				1		(BG02A804G22)				
11	—	REMOTE CONTROLLER	PAR-21MAA	1	1	1	1					

**STRUCTURAL PART
PCFY-P15NGMU-E**

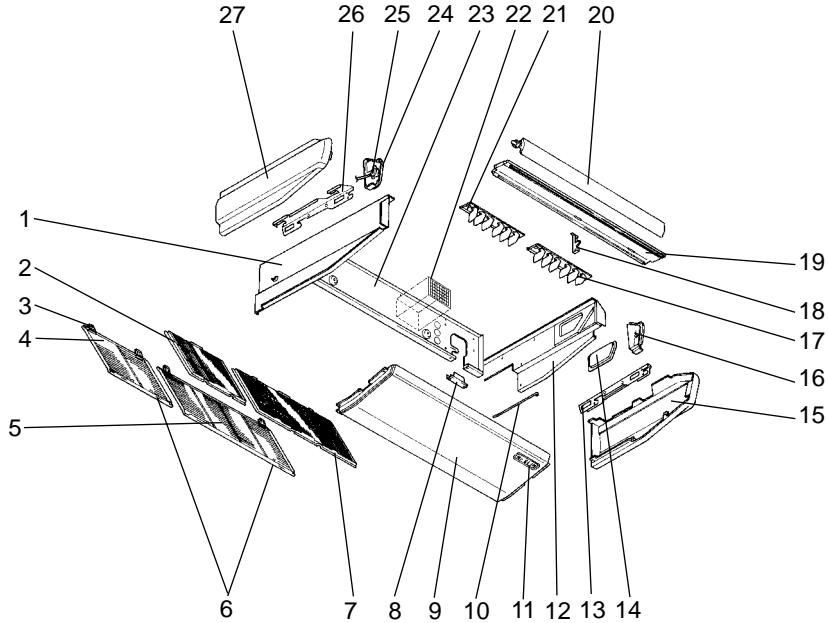

Part number that is circled is not shown in the figure.

No.	Parts No.	Parts Name	Specifications	Q'ty/set	Remarks (Drawing No.)	Wiring Diagram Symbol	Recom- mended Q'ty	Price	
				PCFY- P15NGMU-E				Unit	Amount
1	T7W E01 666	S.PLATE-L		1					
2	R01 A15 500	L.L FILTER		1					
3	R01 17J 061	GRILLE HINGE		4					
4	R01 18J 691	GRILLE ASSY		1					
5	R01 17J 691	GRILLE ASSY		1					
6	R01 17J 054	GRILLE CATCH		4					
7	R01 A14 500	L.L FILTER		1					
8	—	REAR SUPPORT		1	(BG02H454K01)				
9	R01 17J 669	UNDER PANEL		1					
10	—	BEAM(GA)		2	(BG17H464H08)				
11	T7W E00 070	W.BOARD CASE		1					
12	T7W E01 665	S.PLATE-R		1					
13	R01 17J 808	RIGHT LEG (R)		1					
14	T7W E05 668	SERVICE PANEL		1					
15	R01 17J 661	RIGHT SIDE PANEL		1					
16	R01 17J 067	RIGHT SIDE BOX		1					
17	R01 17J 085	G.V ASSY-6R		1					
18	R01 E00 033	VANE SUPPORT		1					
19	T7W E04 651	FRONT PANEL		1					
20	R01 17J 002	AUTO VANE		1					
21	R01 18J 086	G.V ASSY-6L		1					
22	T7W E00 501	AIR FILTER		1					
23	T7W E04 676	REAR PANEL		1					
24	R01 17J 068	LEFT SIDE BOX		1					
25	R01 E03 223	VANE MOTOR		1		MV			
26	R01 17J 809	LEFT LEG (L)		1					
27	R01 17J 662	LEFT SIDE PANEL		1					
28	R01 17J 523	JOINT SOCKET		1					

STRUCTURAL PART
PCFY-P24NGMU-E
PCFY-P30NGMU-E

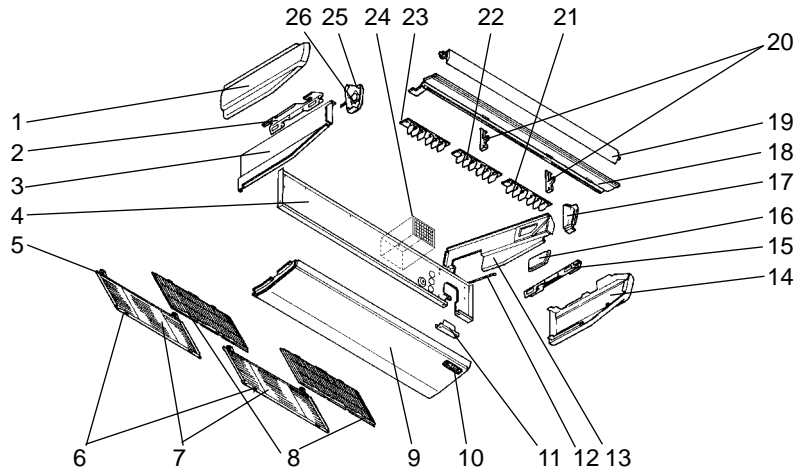

Part number that is circled is not show in the figure.

No.	Parts No.	Parts Name	Specifications	Q'ty/set		Remarks (Drawing No.)	Wiring Diagram Symbol	Recom- mended Q'ty	Price	
				PCFY- P24NGMU-E	P30NGMU-E				Unit	Amount
1	R01 17J 662	LEFT SIDE PANEL		1						
	R01 35J 662	LEFT SIDE PANEL			1					
2	R01 17J 809	LEFT LEG		1	1					
3	T7W E01 666	S.PLATE-L		1						
	T7W E00 666	S.PLATE-L			1					
4	T7W E05 676	REAR PANEL		1						
	T7W E00 676	REAR PANEL			1					
5	R01 17J 061	GRILLE HINGE		4	4					
6	R01 17J 054	GRILLE CATCH		4	4					
7	R01 17J 691	GRILLE ASSY		2	2					
8	R01 A14 500	L.L FILTER		2	2					
9	R01 29J 669	UNDER PANEL		1	1					
10	T7W E00 070	W.BOARD CASE		1	1					
11	—	REAR SUPPORT		1	1	(BG02H454K01)				
12	—	BEAM (GA)		2	2	(BG17H464H08)				
13	T7W E01 665	S.PLATE-R		1						
	T7W E02 665	S.PLATE-R			1					
14	R01 17J 661	RIGHT SIDE PANEL		1						
	R01 35J 661	RIGHT SIDE PANEL			1					
15	R01 17J 808	RIGHT LEG		1	1					
16	T7W E05 668	SERVICE PANEL		1						
	T7W E01 668	SERVICE PANEL			1					
17	R01 17J 067	RIGHT SIDE BOX		1						
	R01 35J 067	RIGHT SIDE BOX			1					
18	T7W E05 651	FRONT PANEL		1						
	T7W E00 651	FRONT PANEL			1					
19	R01 29J 002	AUTO VANE		1						
	R01 E03 002	AUTO VANE			1					
20	R01 E00 033	VANE SUPPORT		2						
	R01 E01 033	VANE SUPPORT			2					
21	R01 17J 085	G.V ASSY-6R		1						
	R01 37J 085	G.V ASSY-6R			1					
22	R01 29J 087	G.V ASSY-6C		1						
	R01 37J 087	G.V ASSY-6C			1					
23	R01 18J 086	G.V ASSY-6L		1						
	R01 37J 086	G.V ASSY-6L			1					
24	T7W E01 501	AIR FILTER		1						
	T7W 051 501	AIR FILTER			1					
25	R01 17J 068	LEFT SIDE BOX		1						
	R01 E00 068	LEFT SIDE BOX			1					
26	R01 29J 223	VANE MOTOR		1			MV			
	R01 35J 223	VANE MOTOR			1		MV			
27	R01 17J 523	JOINT SOCKET		1	1					

STRUCTURAL PART PCFY-P36NGMU-E

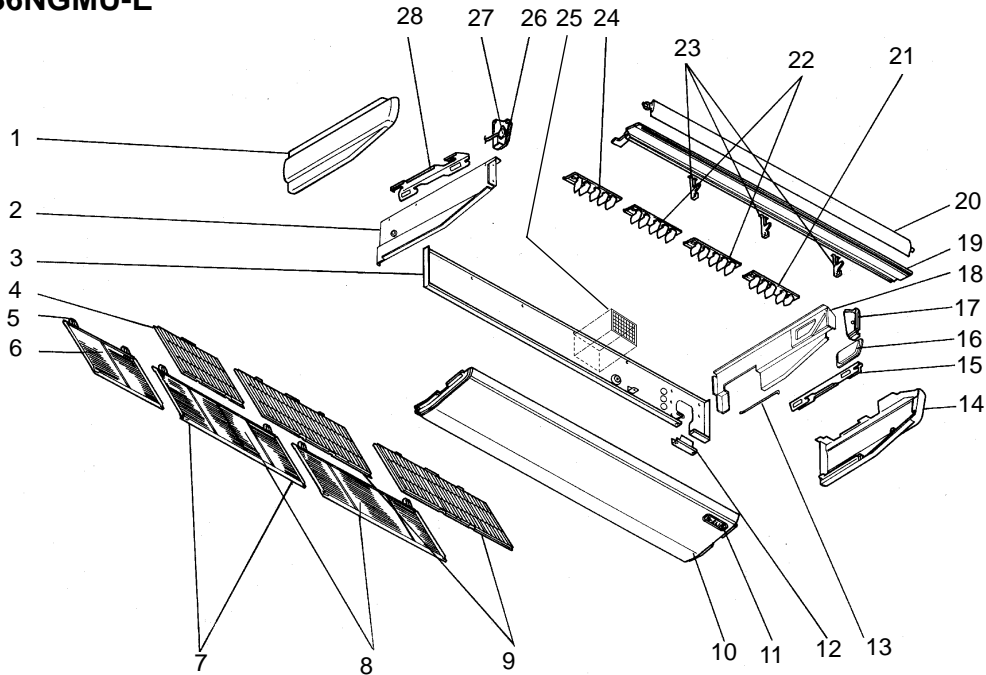

Part number that is circled is not shown in the figure.

No.	Parts No.	Parts Name	Specifications	Q'ty/set	Remarks (Drawing No.)	Wiring Diagram Symbol	Recom- mended Q'ty	Price	
				PCFY- P36NGMU-E				Unit	Amount
1	R01 35J 662	LEFT SIDE PANEL		1					
2	T7W E00 666	S.PLATE-L		1					
3	T7W E01 676	REAR PANEL		1					
4	R01 A15 500	L.L FILTER		1					
5	R01 17J 061	GRILLE HINGE		6					
6	R01 18J 691	GRILLE ASSY		1					
7	R01 17J 054	GRILLE CATCH		6					
8	R01 17J 691	GRILLE ASSY		2					
9	R01 A14 500	L.L FILTER		2					
10	R01 41J 669	UNDER PANEL		1					
11	T7W E00 070	W.BOARD CASE		1					
12	—	REAR SUPPORT		1	(BG02H454K01)				
13	—	BEAM(GA)		3	(BG17H464H08)				
14	R01 35J 661	RIGHT SIDE PANEL		1					
15	R01 17J 808	RIGHT LEG		1					
16	T7W E01 668	SERVICE PANEL		1					
17	R01 35J 067	RIGHT SIDE BOX		1					
18	T7W E02 665	S.PLATE-R		1					
19	T7W E01 651	FRONT PANEL		1					
20	R01 E04 002	AUTO VANE		1					
21	R01 41J 085	G.V ASSY-5R		1					
22	R01 43J 087	G.V ASSY-5C		2					
23	R01 E01 033	VANE SUPPORT		3					
24	R01 42J 086	G.V ASSY-5L		1					
25	T7W 051 501	AIR FILTER		1					
26	R01 E00 068	LEFT SIDE BOX		1					
27	R01 35J 223	VANE MOTOR		1		MV			
28	R01 17J 809	LEFT LEG		1					
⑨	R01 17J 523	JOINT SOCKET		1					

FAN PARTS
PCFY-P15NGMU-E

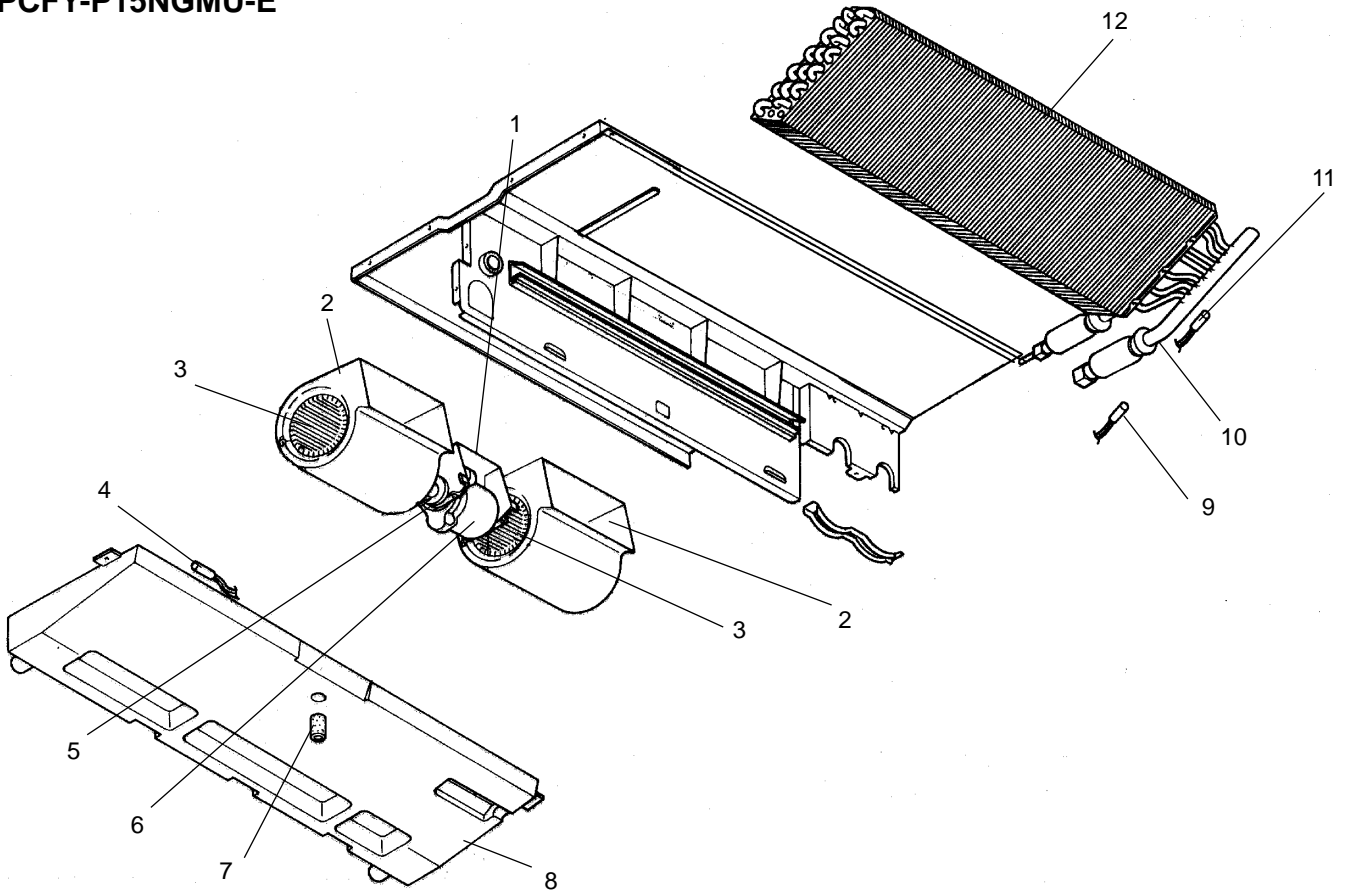

Part number that is circled is not shown in the figure.

No.	Parts No.	Parts Name	Specifications	Q'ty/set	Remarks (Drawing No.)	Wiring Diagram Symbol	Recom- mended Q'ty	Price	
				PCFY- P15NGMU-E				Unit	Amount
1	R01 17J 130	MOTOR LEG		1					
2	T7W B06 110	CASING		2					
3	R01 17J 114	SIROCCO FAN		2					
4	R01 E26 202	ROOM TEMPERATURE THERMISTOR		1		TH21			
5	R01 43E 126	PIECE (MOTOR)	2pcs/set	1					
6	T7W 23J 762	FAN MOTOR	D09B4P54MS	1		MF			
7	R01 17J 524	DRAIN PLUG		1					
8	T7W E19 529	DRAIN PAN ASSY		1					
9	R01 E27 202	LIQUID PIPE TEMPERATURE THERMISTOR		1		TH22			
10	R01 E60 401	LINEAR EXPANSION VALVE		1		LEV			
11	R01 17J 202	GAS PIPE TEMPERATURE THERMISTOR		1		TH23			
12	T7W K21 480	HEAT EXCHANGER		1					
13	T7W E00 072	DRAIN HOSE COVER		1					

FAN PARTS
PCFY-P24NGMU-E
PCFY-P30NGMU-E

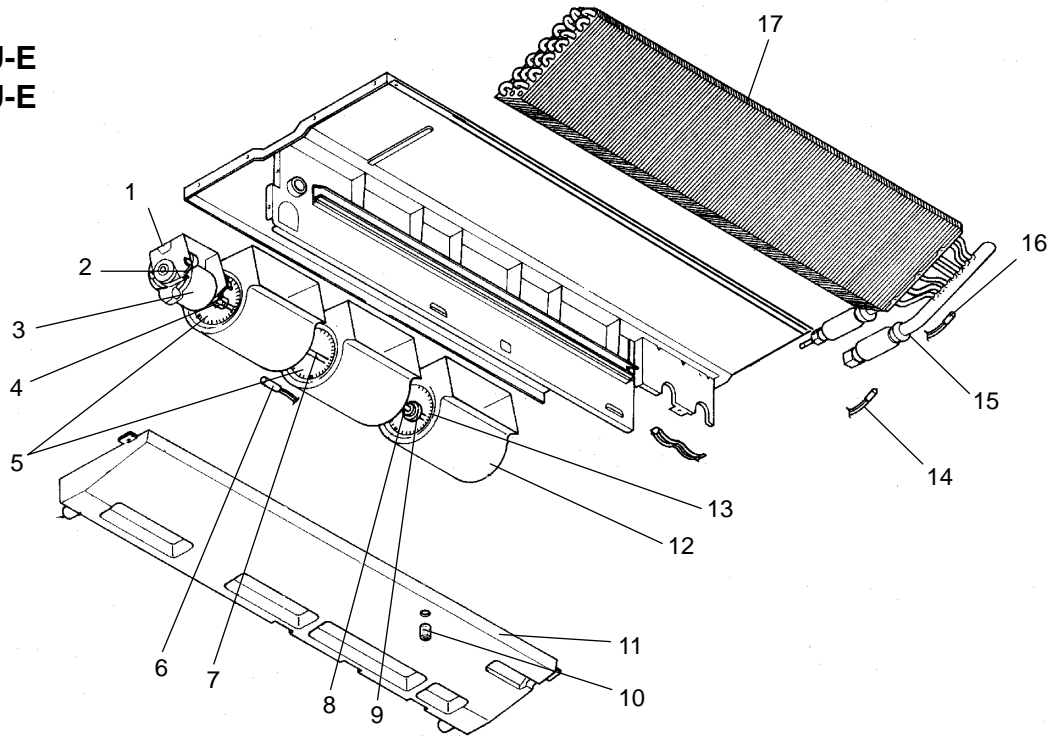

Part number that is circled is not shown in the figure.

No.	Parts No.	Parts Name	Specifications	Q'ty/set		Remarks (Drawing No.)	Wiring Diagram Symbol	Recom- mended Q'ty	Price	
				P24NGMU-E	P30NGMU-E				Unit	Amount
1	R01 29J 130	MOTOR LEG		1						
	R01 35J 130	MOTOR LEG			1					
2	R01 43E 126	PIECE(MOTOR)	2pcs/set	1	1					
3	T7W 30J 762	FAN MOTOR	D09C4P70MS	1			MF			
	T7W E14 762	FAN MOTOR	D10C4P90MS		1		MF			
4	R01 700 116	SHAFT JOINT		1	1					
5	R01 29J 114	SIROCCO FAN		2						
	R01 35J 114	SIROCCO FAN			2					
6	R01 E26 202	ROOM TEMPERATURE THERMISTOR		1	1		TH21			
7	R01 29J 100	SHAFT		1	1					
8	R01 E00 103	SLEEVE BEARING		1	1					
	R01 29J 145	BEARING SUPPORT		1						
9	R01 35J 145	BEARING SUPPORT			1					
	R01 17J 524	DRAIN PLUG		1	1					
11	T7W E20 529	DRAIN PAN ASSY		1						
	T7W E15 529	DRAIN PAN ASSY			1					
12	T7W B06 110	CASING		3						
	T7W B07 110	CASING			3					
13	R01 33J 114	SIROCCO FAN		1						
	R01 39J 114	SIROCCO FAN			1					
14	R01 E27 202	LIQUID PIPE TEMPERATURE THERMISTOR		1	1		TH22			
15	R01 E60 401	LINEAR EXPANSION VALVE		1			LEV			
	R01 E61 401	LINEAR EXPANSION VALVE			1		LEV			
16	R01 17J 202	GAS PIPE TEMPERATURE THERMISTOR		1	1		TH23			
17	T7W K22 480	HEAT EXCHANGER		1						
	T7W K23 480	HEAT EXCHANGER			1					
18	T7W E00 072	DRAIN HOSE COVER		1	1					

FAN PARTS
PCFY-P36NGMU-E

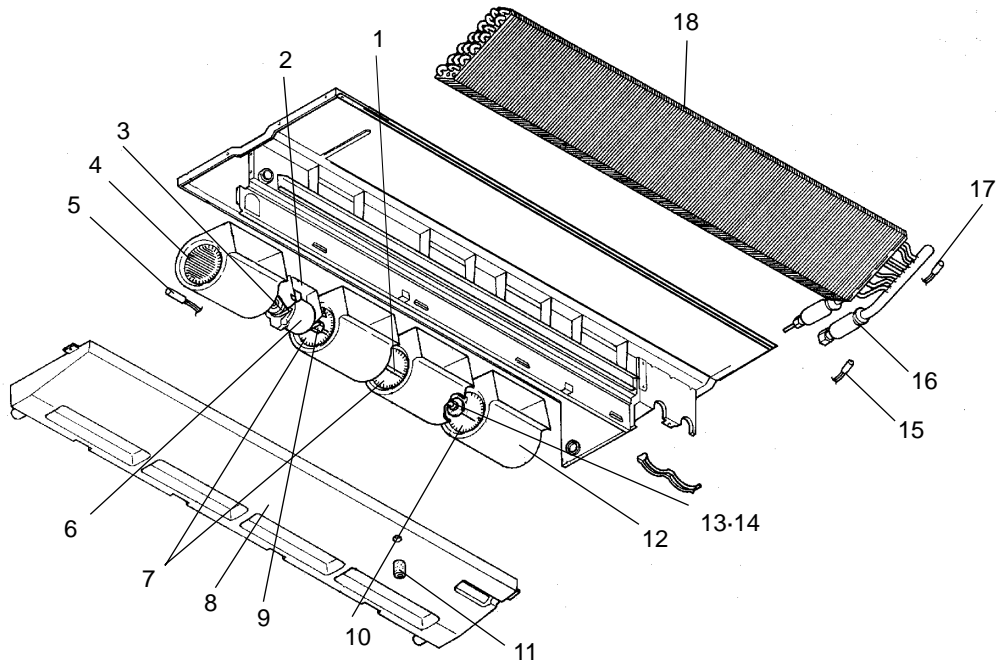

Part number that is circled is not shown in the figure.

No.	Parts No.	Parts Name	Specifications	Q'ty/set PCFY- P36NGMU-E	Remarks (Drawing No.)	Wiring Diagram Symbol	Recom- mended Q'ty	Price	
								Unit	Amount
1	R01 29J 100	SHAFT		1					
2	R01 41J 130	MOTOR LEG		1					
3	R01 43E 126	PIECE (MOTOR)	2pcs/set	1					
4	R01 41J 114	SIROCCO FAN		1					
5	R01 E26 202	ROOM TEMPERATURE THERMISTOR		1		TH21			
6	T7W E15 762	FAN MOTOR	D10D4P150MS	1		MF			
7	R01 35J 114	SIROCCO FAN		2					
8	T7W E16 529	DRAIN PAN ASSY		1					
9	R01 700 116	SHAFT JOINT		1					
10	R01 39J 114	SIROCCO FAN		1					
11	R01 17J 524	DRAIN PLUG		1					
12	T7W B07 110	CASING		4					
13	R01 E00 103	SLEEVE BEARING		1					
14	R01 35J 145	BEARING SUPPORT		1					
15	R01 E27 202	LIQUID PIPE TEMPERATURE THERMISTOR		1		TH22			
16	R01 E61 401	LINEAR EXPANSION VALVE		1		LEV			
17	R01 17J 202	GAS PIPE TEMPERATURE THERMISTOR		1		TH23			
18	T7W K24 480	HEAT EXCHANGER		1					
①9	T7W E00 072	DRAIN HOSE COVER		1					

ELECTRICAL PARTS

PCFY-P15NGMU-E

PCFY-P24NGMU-E

PCFY-P30NGMU-E

PCFY-P36NGMU-E

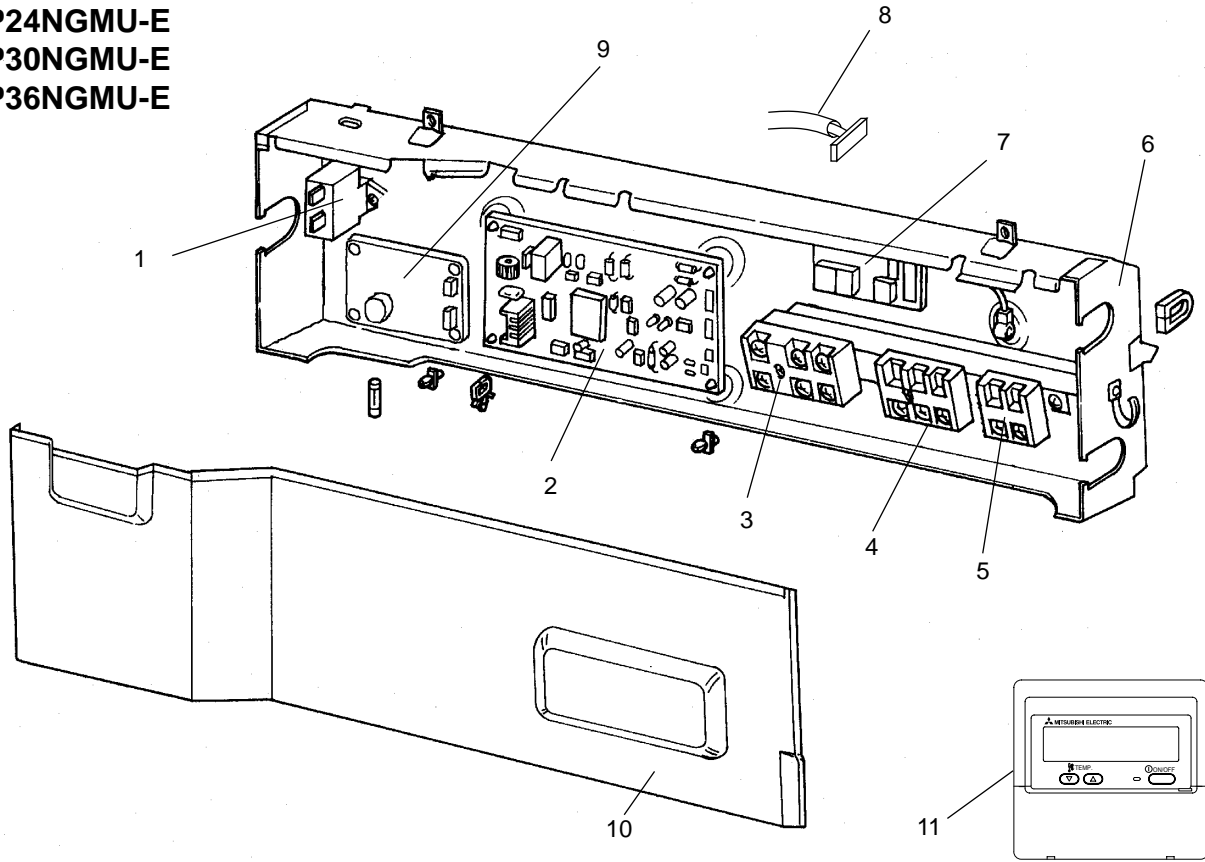

No.	RoHS	Parts No.	Parts Name	Specifications	Q'ty/set				Remarks (Drawing No.)	Wiring Diagram Symbol	Recom- mended Q'ty	Price	
					PCFY-P • NGMU-E							Unit	Amount
					15	24	30	36					
1	G	T7W E15 255	CAPACITOR	3 μ F 440V	1				C1				
	G	T7W E18 255	CAPACITOR	4 μ F 440V		1			C1				
	G	T7W E19 255	CAPACITOR	5 μ F 440V			1		C1				
	G	R01 E14 255	CAPACITOR	7 μ F 440V				1	C1				
2	G	T7W E57 310	INDOOR CONTROLLER BOARD		1	1	1	1	I.B				
3	G	T7W E41 716	TERMINAL BLOCK	3P(L1,L2,GR)	1	1	1	1	TB2				
4	G	R01 E27 246	TERMINAL BLOCK	3P(M1,M2,S)	1	1	1	1	TB5				
5	G	R01 E21 246	TERMINAL BLOCK	2P(1,2)	1	1	1	1	TB15				
6	G	—	CONTROL BOX		1	1	1	1	(BG00N015G31)				
7	G	T7W E01 294	ADDRESS BOARD		1	1	1	1	A.B				
8	G	R01 A01 304	ADDRESS CABLE		1	1	1	1					
9	G	R01 E38 313	POWER BOARD		1	1	1	1	P.B				
10	G	—	BOX COVER		1				(BG02A804G20)				
	G	—	BOX COVER			1		1	(BG02A804G21)				
	G	—	BOX COVER				1		(BG02A804G22)				
11	G	—	REMOTE CONTROLLER	PAR-21MAA	1	1	1	1					

STRUCTURAL PART PCFY-P15NGMU-E

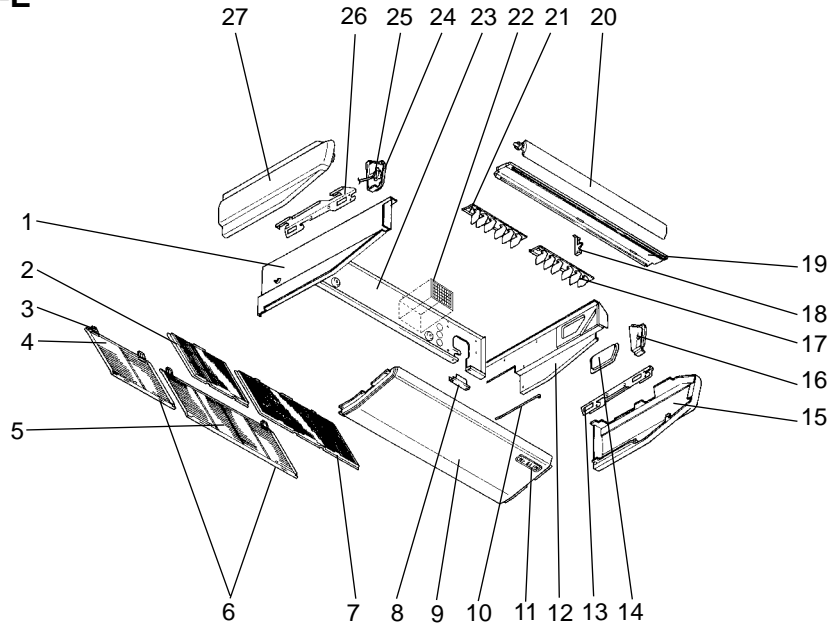

Part number that is circled is not shown in the figure.

No.	RoHS	Parts No.	Parts Name	Specifications	Q'ty/set	Remarks (Drawing No.)	Wiring Diagram Symbol	Recom- mended Q'ty	Price	
					PCFY- P15NGMU-E				Unit	Amount
1	G	T7W E02 666	S.PLATE-L		1					
2	G	R01 A30 500	L.L FILTER		1					
3	G	R01 18J 061	GRILLE HINGE		4					
4	G	R01 19J 691	GRILLE ASSY		1					
5	G	R01 20J 691	GRILLE ASSY		1					
6	G	R01 19J 054	GRILLE CATCH		4					
7	G	R01 A29 500	L.L FILTER		1					
8	G	—	REAR SUPPORT		1	(BG02H454K01)				
9	G	R01 31J 669	UNDER PANEL		1					
10	G	—	BEAM(GA)		2	(BG17H464H08)				
11	G	T7W E03 070	W.BOARD CASE		1					
12	G	T7W E03 665	S.PLATE-R		1					
13	G	R01 18J 808	RIGHT LEG (R)		1					
14	G	T7W E10 668	SERVICE PANEL		1					
15	G	R01 18J 661	RIGHT SIDE PANEL		1					
16	G	R01 18J 067	RIGHT SIDE BOX		1					
17	G	R01 40J 085	G.V ASSY-6R		1					
18	G	R01 E02 033	VANE SUPPORT		1					
19	G	T7W E07 651	FRONT PANEL		1					
20	G	R01 31J 002	AUTO VANE		1					
21	G	R01 40J 086	G.V ASSY-6L		1					
22	G	T7W E02 501	AIR FILTER		1					
23	G	T7W E06 676	REAR PANEL		1					
24	G	R01 18J 068	LEFT SIDE BOX		1					
25	G	R01 E11 223	VANE MOTOR		1		MV			
26	G	R01 18J 809	LEFT LEG (L)		1					
27	G	R01 18J 662	LEFT SIDE PANEL		1					
28	G	R01 18J 523	JOINT SOCKET		1					

STRUCTURAL PART
PCFY-P24NGMU-E
PCFY-P30NGMU-E

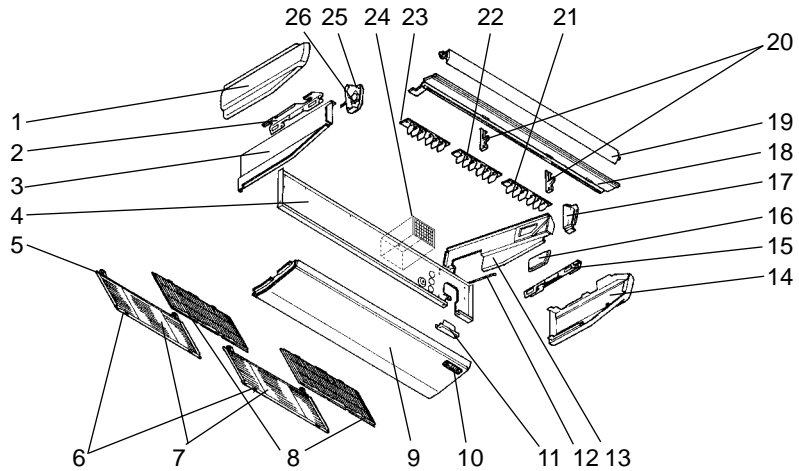

Part number that is circled is not show in the figure.

No.	RoHS	Parts No.	Parts Name	Specifications	Q'ty/set		Remarks (Drawing No.)	Wiring Diagram Symbol	Recom- mended Q'ty	Price	
					PCFY- P24NGMU-E	P30NGMU-E				Unit	Amount
1	G	R01 18J 662	LEFT SIDE PANEL		1						
	G	R01 36J 662	LEFT SIDE PANEL			1					
2	G	R01 18J 809	LEFT LEG		1	1					
3	G	T7W E02 666	S.PLATE-L		1						
	G	T7W E03 666	S.PLATE-L			1					
4	G	T7W E07 676	REAR PANEL		1						
	G	T7W E08 676	REAR PANEL			1					
5	G	R01 18J 061	GRILLE HINGE		4	4					
6	G	R01 19J 054	GRILLE CATCH		4	4					
7	G	R01 19J 691	GRILLE ASSY		2	2					
8	G	R01 A29 500	L.L FILTER		2	2					
9	G	R01 30J 669	UNDER PANEL		1	1					
10	G	T7W E03 070	W.BOARD CASE		1	1					
11	G	—	REAR SUPPORT		1	1	(BG02H454K01)				
12	G	—	BEAM (GA)		2	2	(BG17H464H08)				
13	G	T7W E03 665	S.PLATE-R		1						
	G	T7W E04 665	S.PLATE-R			1					
14	G	R01 18J 661	RIGHT SIDE PANEL		1						
	G	R01 36J 661	RIGHT SIDE PANEL			1					
15	G	R01 18J 808	RIGHT LEG		1	1					
16	G	T7W E10 668	SERVICE PANEL		1						
	G	T7W E11 668	SERVICE PANEL			1					
17	G	R01 18J 067	RIGHT SIDE BOX		1						
	G	R01 36J 067	RIGHT SIDE BOX			1					
18	G	T7W E08 651	FRONT PANEL		1						
	G	T7W E09 651	FRONT PANEL			1					
19	G	R01 30J 002	AUTO VANE		1						
	G	R01 E14 002	AUTO VANE			1					
20	G	R01 E02 033	VANE SUPPORT		2						
	G	R01 E03 033	VANE SUPPORT			2					
21	G	R01 40J 085	G.V ASSY-6R		1						
	G	R01 38J 085	G.V ASSY-6R			1					
22	G	R01 40J 087	G.V ASSY-6C		1						
	G	R01 38J 087	G.V ASSY-6C			1					
23	G	R01 40J 086	G.V ASSY-6L		1						
	G	R01 38J 086	G.V ASSY-6L			1					
24	G	T7W E03 501	AIR FILTER		1						
	G	T7W E04 501	AIR FILTER			1					
25	G	R01 18J 068	LEFT SIDE BOX		1						
	G	R01 E01 068	LEFT SIDE BOX			1					
26	G	R01 E10 223	VANE MOTOR		1			MV			
	G	R01 E12 223	VANE MOTOR		1			MV			
27	G	R01 18J 523	JOINT SOCKET		1	1					

**STRUCTURAL PART
PCFY-P36NGMU-E**

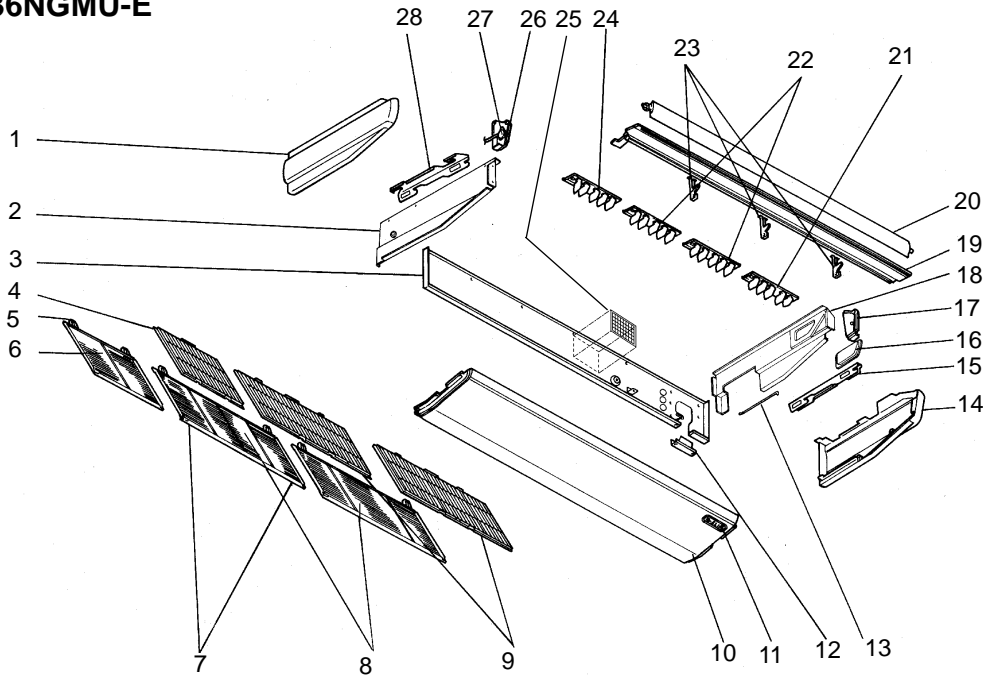

Part number that is circled is not shown in the figure.

No.	ROHS	Parts No.	Parts Name	Specifications	Q'ty/set	Remarks (Drawing No.)	Wiring Diagram Symbol	Recom- mended Q'ty	Price	
					PCFY- P36NGMU-E				Unit	Amount
1	G	R01 36J 662	LEFT SIDE PANEL		1					
2	G	T7W E03 666	S.PLATE-L		1					
3	G	T7W E09 676	REAR PANEL		1					
4	G	R01 A30 500	L.L FILTER		1					
5	G	R01 18J 061	GRILLE HINGE		6					
6	G	R01 20J 691	GRILLE ASSY		1					
7	G	R01 19J 054	GRILLE CATCH		6					
8	G	R01 19J 691	GRILLE ASSY		2					
9	G	R01 A29 500	L.L FILTER		2					
10	G	R01 32J 669	UNDER PANEL		1					
11	G	T7W E03 070	W.BOARD CASE		1					
12	G	—	REAR SUPPORT		1	(BG02H454K01)				
13	G	—	BEAM(GA)		3	(BG17H464H08)				
14	G	R01 36J 661	RIGHT SIDE PANEL		1					
15	G	R01 18J 808	RIGHT LEG		1					
16	G	T7W E11 668	SERVICE PANEL		1					
17	G	R01 36J 067	RIGHT SIDE BOX		1					
18	G	T7W E04 665	S.PLATE-R		1					
19	G	T7W E10 651	FRONT PANEL		1					
20	G	R01 E15 002	AUTO VANE		1					
21	G	R01 39J 085	G.V ASSY-5R		1					
22	G	R01 39J 087	G.V ASSY-5C		2					
23	G	R01 E03 033	VANE SUPPORT		3					
24	G	R01 39J 086	G.V ASSY-5L		1					
25	G	T7W E04 501	AIR FILTER		1					
26	G	R01 E01 068	LEFT SIDE BOX		1					
27	G	R01 E12 223	VANE MOTOR		1		MV			
28	G	R01 18J 809	LEFT LEG		1					
29	G	R01 18J 523	JOINT SOCKET		1					

FAN PARTS
PCFY-P15NGMU-E

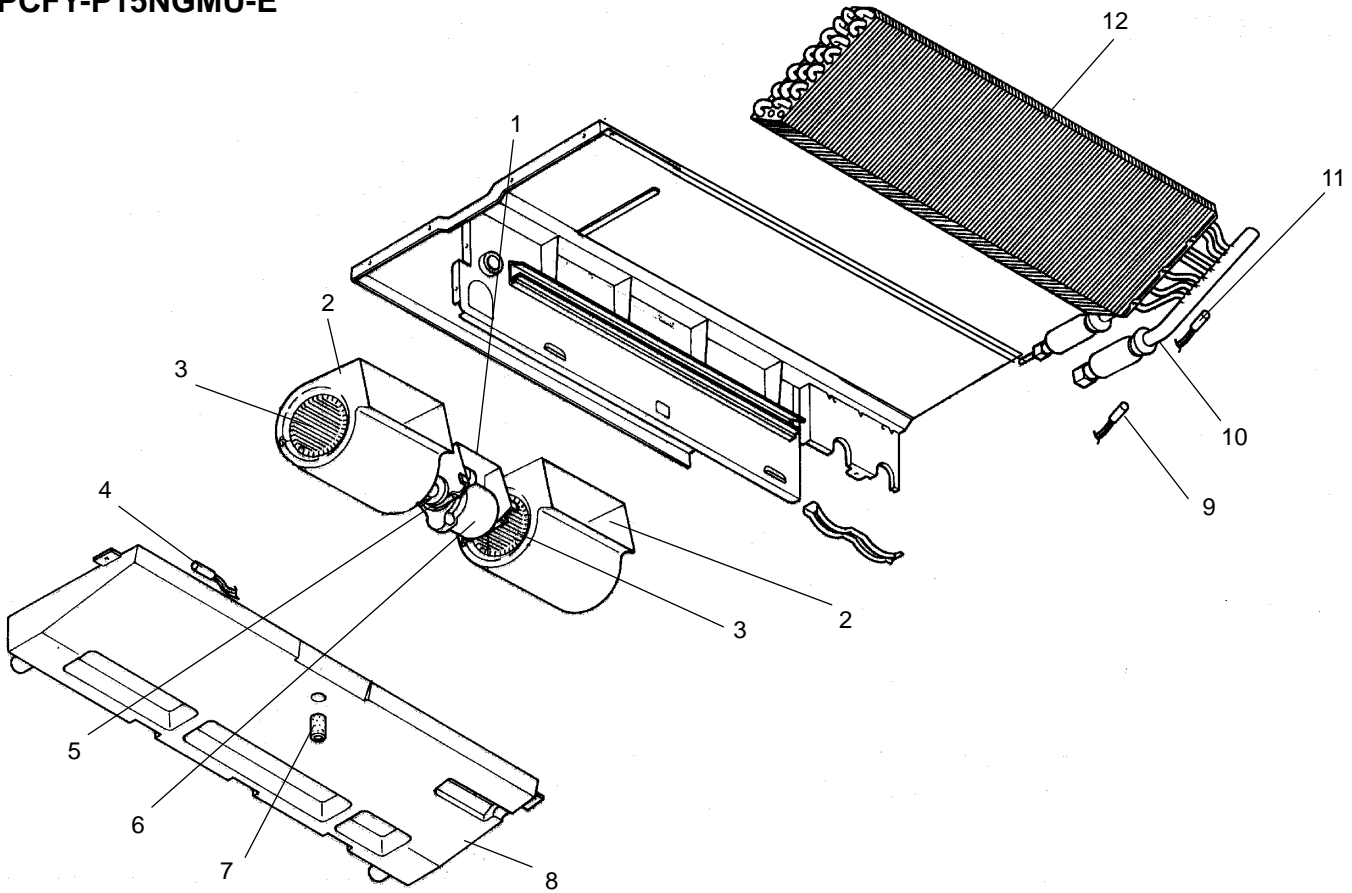

Part number that is circled is not shown in the figure.

No.	RoHS	Parts No.	Parts Name	Specifications	Q'ty/set	Remarks (Drawing No.)	Wiring Diagram Symbol	Recom- mended Q'ty	Price	
					PCFY- P15NGMU-E				Unit	Amount
1	G	R01 31J 130	MOTOR LEG		1					
2	G	T7W B08 110	CASING		2					
3	G	R01 E16 114	SIROCCO FAN		2					
4	G	R01 H08 202	ROOM TEMPERATURE THERMISTOR		1		TH21			
5	G	R01 45E 126	PIECE (MOTOR)	2pcs/set	1					
6	G	R01 18J 220	FAN MOTOR	D09B4P54MS	1		MF			
7	G	R01 18J 524	DRAIN PLUG		1					
8	G	T7W E29 529	DRAIN PAN ASSY		1					
9	G	R01 H10 202	LIQUID PIPE TEMPERATURE THERMISTOR		1		TH22			
10	G	R01 H02 401	LINEAR EXPANSION VALVE		1		LEV			
11	G	R01 H09 202	GAS PIPE TEMPERATURE THERMISTOR		1		TH23			
12	G	T7W H00 480	HEAT EXCHANGER		1					
13	G	T7W E01 072	DRAIN HOSE COVER		1					

FAN PARTS
PCFY-P24NGMU-E
PCFY-P30NGMU-E

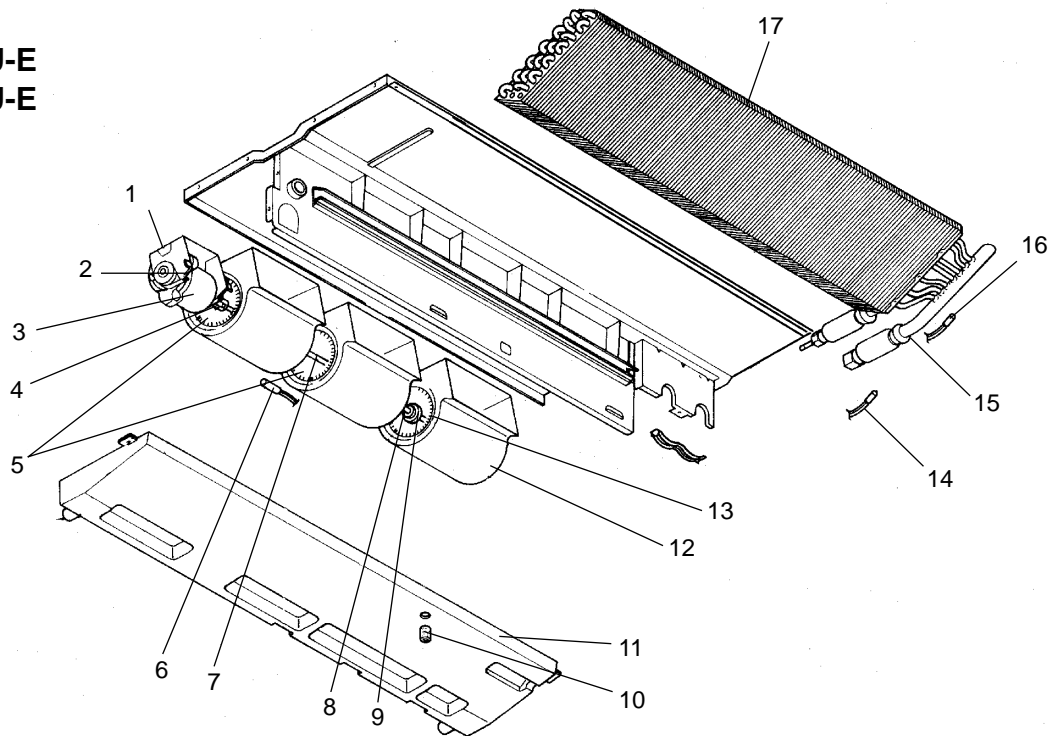

Part number that is circled is not shown in the figure.

No.	RoHS	Parts No.	Parts Name	Specifications	Q'ty/set		Remarks (Drawing No.)	Wiring Diagram Symbol	Recom- mended Q'ty	Price	
					PCFY- P24NGMU-E	P30NGMU-E				Unit	Amount
1	G	R01 30J 130	MOTOR LEG		1						
	G	R01 32J 130	MOTOR LEG			1					
2	G	R01 45E 126	PIECE(MOTOR)	2pcs/set	1	1					
3	G	T7W 40J 762	FAN MOTOR	D09C4P70MS	1			MF			
	G	T7W E31 762	FAN MOTOR	D10C4P90MS		1		MF			
4	G	R01 800 116	SHAFT JOINT		1	1					
5	G	R01 E17 114	SIROCCO FAN		2						
	G	R01 E19 114	SIROCCO FAN			2					
6	G	R01 H08 202	ROOM TEMPERATURE THERMISTOR		1	1		TH21			
7	G	R01 30J 100	SHAFT		1	1					
8	G	R01 E02 103	SLEEVE BEARING		1	1					
9	G	R01 30J 145	BEARING SUPPORT		1						
	G	R01 36J 145	BEARING SUPPORT			1					
10	G	R01 18J 524	DRAIN PLUG		1	1					
11	G	T7W E30 529	DRAIN PAN ASSY		1						
	G	T7W E31 529	DRAIN PAN ASSY			1					
12	G	T7W B08 110	CASING		3						
	G	T7W B09 110	CASING			3					
13	G	R01 E15 114	SIROCCO FAN		1						
	G	R01 E20 114	SIROCCO FAN			1					
14	G	R01 H10 202	LIQUID PIPE TEMPERATURE THERMISTOR		1	1		TH22			
15	G	R01 H02 401	LINEAR EXPANSION VALVE		1			LEV			
	G	R01 E86 401	LINEAR EXPANSION VALVE			1		LEV			
16	G	R01 H09 202	GAS PIPE TEMPERATURE THERMISTOR		1	1		TH23			
17	G	T7W H01 480	HEAT EXCHANGER		1						
	G	T7W K30 480	HEAT EXCHANGER			1					
⑮	G	T7W E01 072	DRAIN HOSE COVER		1	1					

FAN PARTS
PCFY-P36NGMU-E

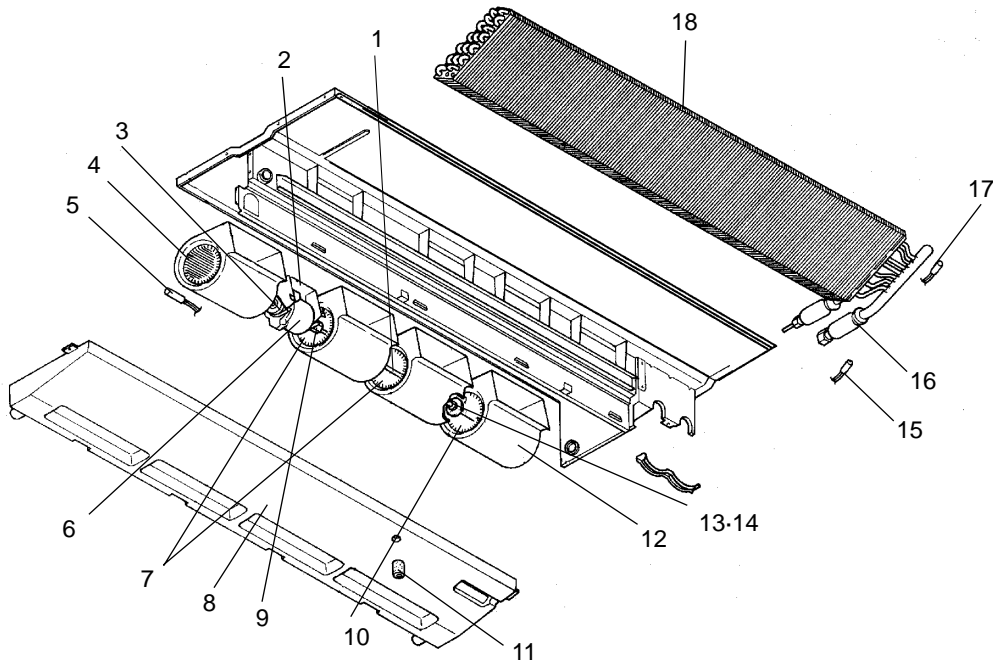

Part number that is circled is not shown in the figure.

No.	RoHS	Parts No.	Parts Name	Specifications	Q'ty/set	Remarks (Drawing No.)	Wiring Diagram Symbol	Recom- mended Q'ty	Price	
					PCFY- P36NGMU-E				Unit	Amount
1	G	R01 30J 100	SHAFT		1					
2	G	R01 33J 130	MOTOR LEG		1					
3	G	R01 45E 126	PIECE (MOTOR)	2pcs/set	1					
4	G	R01 E18 114	SIROCCO FAN		1					
5	G	R01 H08 202	ROOM TEMPERATURE THERMISTOR		1		TH21			
6	G	T7W E32 762	FAN MOTOR	D10D4P150MS	1		MF			
7	G	R01 E19 114	SIROCCO FAN		2					
8	G	T7W E32 529	DRAIN PAN ASSY		1					
9	G	R01 800 116	SHAFT JOINT		1					
10	G	R01 E20 114	SIROCCO FAN		1					
11	G	R01 18J 524	DRAIN PLUG		1					
12	G	T7W B09 110	CASING		4					
13	G	R01 E02 103	SLEEVE BEARING		1					
14	G	R01 36J 145	BEARING SUPPORT		1					
15	G	R01 H10 202	LIQUID PIPE TEMPERATURE THERMISTOR		1		TH22			
16	G	R01 E86 401	LINEAR EXPANSION VALVE		1		LEV			
17	G	R01 H09 202	GAS PIPE TEMPERATURE THERMISTOR		1		TH23			
18	G	T7W K31 480	HEAT EXCHANGER		1					
⑰	G	T7W E01 072	DRAIN HOSE COVER		1					

12**OPTIONAL PARTS****HIGH EFFICIENCY FILTER**

Part No.	PAC-SE80KF-E	PAC-SE81KF-E	PAC-SE82KF-E
Applied Service Ref.	PCFY-P15NGMU-E	PCFY-P24NGMU-E PCFY-P30NGMU-E	PCFY-P36NGMU-E

CITY MULTI



HEAD OFFICE : TOKYO BLDG., 2-7-3, MARUNOUCHI, CHIYODA-KU, TOKYO100-8310, JAPAN