

IT COOLING

ROOM COOLING

S-MEXT-G02 M1

**FULL INVERTER AIR CONDITIONING SPLIT SYSTEM
FOR SMALL AND MEDIUM SIZE IT ENVIRONMENTS
FROM 6 TO 13 kW**



 **INVERTER**

 **EEV**

 **EC FAN**

R **HFC R410A**

S-MEXT-G02 M1

Highest energy efficiency, reduced footprint and unchallenged quality for small and medium data centers.

Building on the strong legacy of the RC brand in IT Cooling, Mitsubishi Electric presents s-MEXT-G02-M1:

The new split cooling system that joins together the best of RC experience and technology with the highest quality and reliability standards of Mitsubishi Electric.

Engineered with the best kW/m² ratio and a green approach, this innovative cooling package gets your data center ready for the future.

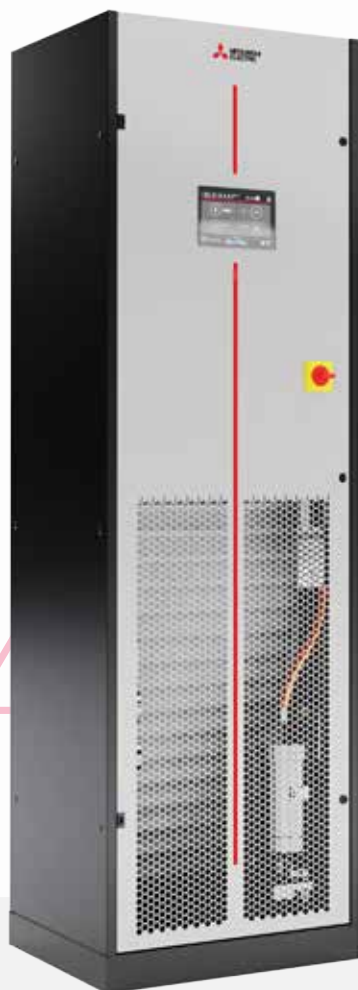

s-MEXT-G02-M1
+Mr. Slim with R410A refrigerant



r R410A

HIGHEST CAPACITY PER FOOTPRINT

Thanks to the split design, the indoor s-MEXT-G02-M1 air conditioner matches the highest efficiency levels with the industry's most compact footprint.

Its small size design means they can be easily integrated in small IT rooms or existing environments, all without sacrificing any kW per square meter.

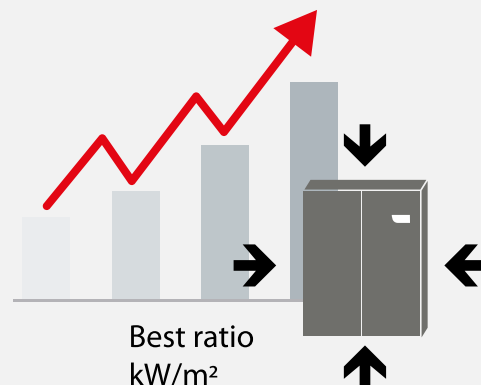

EXCEEDING YOUR EFFICIENCY TARGETS

Air conditioning and cooling systems account for about 40% of total electricity usage in data centers. An optimal cooling approach can lead your organization towards the path of energy efficiency, with great benefits in terms of cost savings.

Both the s-MEXT-G02-M1 and Mr. Slim units feature best-in-class components aimed at reducing power consumption and advanced logics to efficiently control the whole cooling system.

- ▶ INVERTER COMPRESSORS in the Mr. Slim units, for the continuous modulation of the refrigeration power
- ▶ DC fans for Mr. Slim and EC fans for s-MEXT-G02-M1 units that ensure a perfect airflow modulation

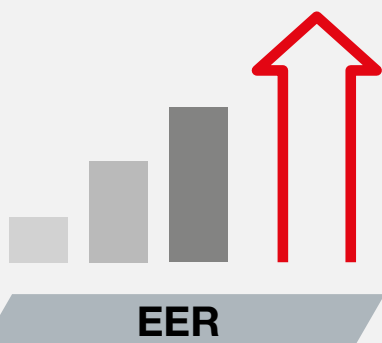

BEYOND TRADITIONAL OPERATING LIMITS

Increased power densities in IT environments have led to growing temperatures (up to 23°C) of intake airflows directed to the IT equipment (ASHRAE 'Thermal Guidelines for Data Processing Environments').

The s-MEXT-G02-M1 and Mr Slim cooling package has been designed to manage return air temperatures up to 35°C, matching the requirements of the most critical data centers (up to 52 °C outdoor air temperature).

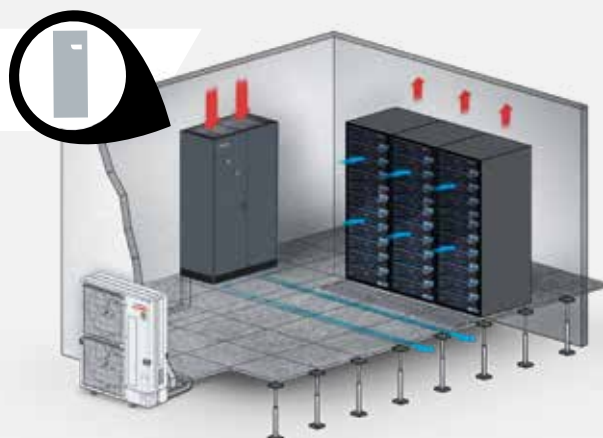



s-MEXT-G02 M1

HARNESSING THE HIGHEST CAPACITY INTO A SMALL FOOTPRINT

s-MEXT-G02-M1 controls temperature and relative humidity with pinpoint accuracy, even in case of very strong thermal variations. Brilliantly engineered to deliver top-class efficiency values, the indoor unit features premium quality components: EC plug fans, evaporating coil with hydrophilic treatment, electrical panel and PID microprocessor control system. A wide range of accessories are also available to match also the most critical installation requirements.

s-MEXT-G02-M1 series is equipped with components, safety devices, and control logics making it suitable to be paired with Mr. Slim with R410A.

New generation Inverter EC fans



High performing EC fans made of polymeric ultralight material in order to ensure perfect airflow modulation at partial loads. The fans deliver great advantages in terms of:

- ▶ Reduction of noise levels by 4-5 dB(A) compared to traditional solutions
- ▶ Reduction of the absorbed power by 25% compared to traditional solutions

Fast installation and easy maintenance

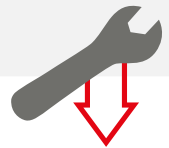

The constructive features and the internal layout guarantee faster installation and the frontal access to the main components make routine inspections easier.

EVOLUTION+ Advanced Unit Control

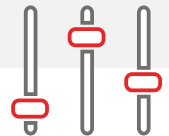

The electronic heart of the unit is the EVOLUTION+ controller. Designed internally to perfectly manage all the unit's variables, it features evolved characteristics in order to make the unit totally configurable:

- ▶ Automatic reactivation after black-out
- ▶ Serial cards for BMS interfacing
- ▶ BLACK BOX for preventive analyses
- ▶ Up to 100 events recorded
- ▶ Non-volatile 'flash' memory for data storage
- ▶ Display with easy-to-read graphic icons

Mr. SLIM



Remote condensing unit for outdoor installation featuring EC inverter compressor and axial fans with DC motor and stepless speed control.

By using a special power receiver to sub-cool the refrigerant, together with two individually controlled expansion valves, the units work within the optimum range in any operating state.

The inverters are perfectly combined with the indoor s-MEXT-G02-M1 units through a PAC-IF013 board.

DC Inverter compressor



The full inverter compressor allows for the modulation of the refrigeration power based on the real needs, thus increasing the efficiency at partial loads.

- ▶ No in-rush current
- ▶ Energy savings up to 50% compared to traditional on/off units
- ▶ Utmost reliability thanks to the continuous operation without on/off cycles

Main Features



Developed for high-performance operation, the Power Inverters offer a host of special functions:

- ▶ Redundancy functions with automatic switchover in the event of a fault and delay correction
- ▶ Easy Maintenance function and automatic refrigerant level monitoring

Linear Expansion Valve (LEV)

The linear expansion valve of Mr. Slim ensures a wide modulation of the power cooling, thus optimising the compressor performance according to its operating field variation.

- ▶ Rapid achievement of the system stability
- ▶ Accurate adaptation to load fluctuations

S-MEXT-G02 M2



s-MEXT-G02-M1

S 006

S 013

SIZE		F1	F1
VERSION	(1)	U / O	U / O
INDOOR UNIT			
COOLING CAPACITY (2)			
Total	kW	6.56	11.7
Sensible	kW	6.56	10.3
SHR	(3)	1.00	0.88
System EER (nominal)	BTU/W*h	15.10	10.87
"EC" SUPPLY FAN			
Air flow	No.	1	1
	m³/h	2235	2606
SOUND LEVEL ISO 3744 (4)			
Pressure level	dB(A)	57	61
Power level	dB(A)	73	77
REFRIGERANT CIRCUITS			
	No.	1	1
POWER SUPPLY			
	V/Ph/Hz	208-230/1/60	208-230/1/60
DIMENSIONS			
Length (A)	mm	600	600
Depth (B)	mm	500	500
Height (H)	mm	1980	1980
NET WEIGHT			
	kg	106	120

Mr. Slim

PUY-A24

PUY-A42

Quantity	No.	1	1
Model	PUY	A42NHA7	A24NHA7
Power input	(5) kW	1.17	3.24
Power Supply	V/Ph/Hz	208-230/1/60	208-230/1/60
Power supply wiring cable	(6) No. x mm ²	3G4	5G1.5

Notes:

- Indoor conditions (in) 27°C - R.H. 47%; Outdoor air temperature 35°C; ESP= 20Pa.
- SHR = Sensible cooling capacity gross / Total cooling capacity gross.
- Unit in standard configuration/execution, without optional accessories.
- Average sound pressure level, at a distance of 1m, for units in a free field on a reflecting surface.
The average sound pressure level is calculated based on the sound power level measured in accordance with ISO 3744.
- Gross value. Characteristics referred to entering air at 27°C-47% RH; Ambient temperature 35°C; ESP=20Pa.
- Minimum section of the power cable for units without accessories.

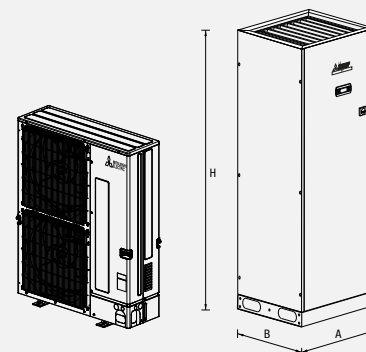

INSTALLATION OPPORTUNITIES

Extreme installation flexibility of the unit, which is available with two types of air supply.

UNDER

WITH BOTTOM AIR SUPPLY,
AND TOP AIR RETURN.

IDEAL FOR ROOMS
WITH RAISED FLOOR.

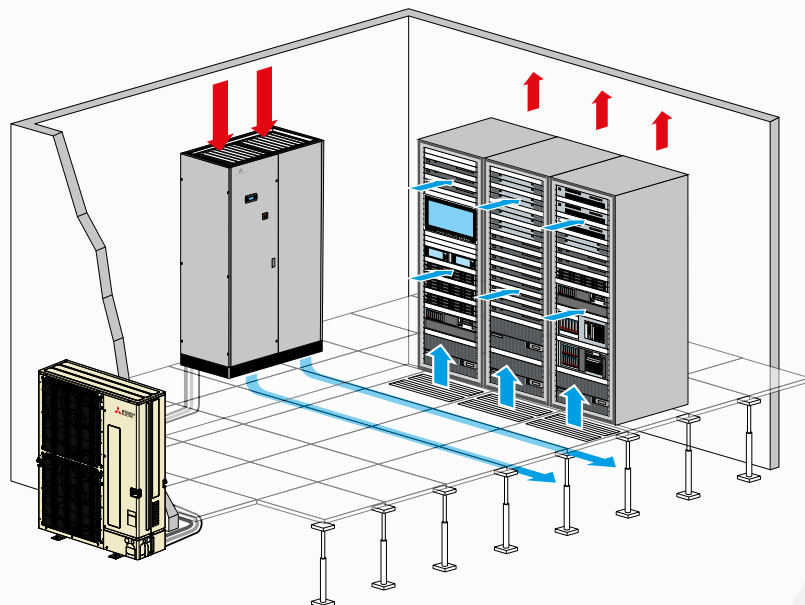

OVER

WITH TOP AIR SUPPLY
AND FRONTAL AIR RETURN.

IDEAL FOR ROOMS
WITH STANDARD FLOOR.

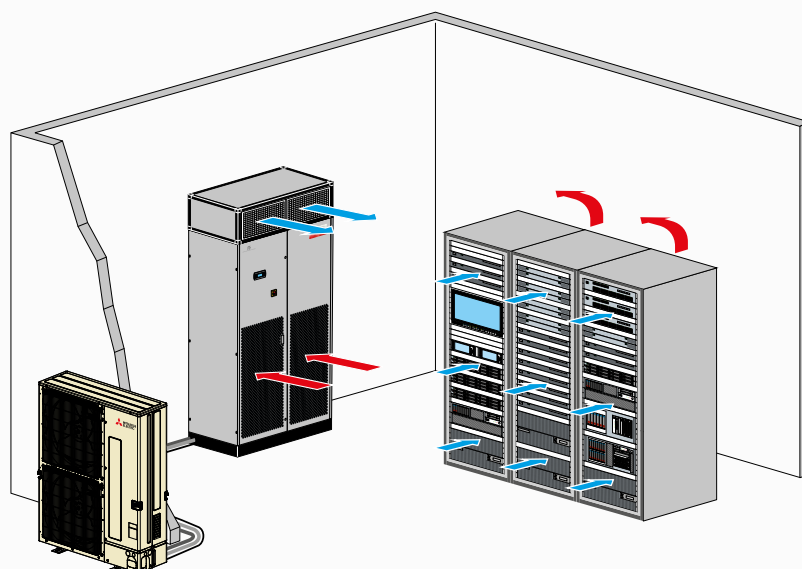



Heating and Cooling



Mitsubishi Electric Sales Canada Inc.

4299 14th Avenue,
Markham Ontario, L3R 0J2

MEM-202205-E © 2022 Mitsubishi Electric Sales Canada Inc. All rights reserved. Mitsubishi Electric reserves the right to modify the design of its products, their characteristics and the information contained in this literature. Specifications are subject to change without notice.