

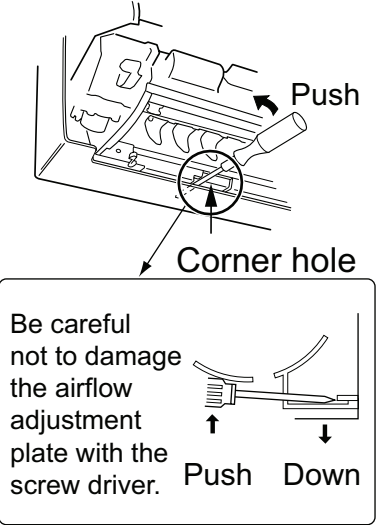
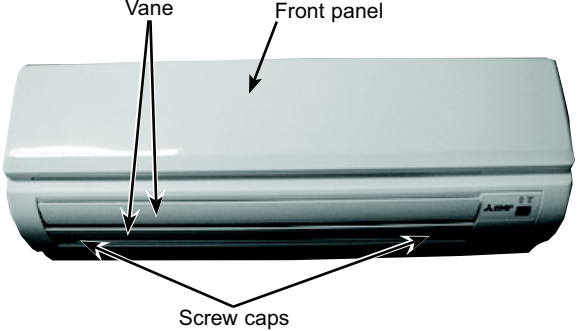

PKA-A12HA PKA-A18HA PKA-A12HAL PKA-A18HAL

Be careful when removing heavy parts.

OPERATION PROCEDURE	PHOTOS & ILLUSTRATIONS
<p>1. REMOVING THE LOWER SIDE OF THE INDOOR UNIT FROM THE INSTALLATION PLATE</p> <ol style="list-style-type: none"> (1) Remove the front panel. (2) Insert the screw driver to the corner hole at both left and right side as shown in the figure 1. (3) Push it up, then pull down the lower side of indoor unit and remove the hook. 	<p>Figure 1</p> 
<p>2. REMOVING THE FRONT PANEL</p> <ol style="list-style-type: none"> (1) Press and unlock the knobs on both sides of the front panel and lift the front panel until it is level. Pull the hinges forward to remove the front panel. (See Photo 2) (2) Move the horizontal vanes in a downward direction. (3) Remove the screw caps of the panel. Remove the screws. (See Photo 1) (4) Hold the lower part of both ends of the panel and pull it slightly toward you, and then remove the panel by pushing it upward. 	<p>Photo 1</p>  <p>Photo 2</p> 

OPERATION PROCEDURE

3. REMOVING THE INDOOR CONTROLLER BOARD AND WIRELESS CONTROLLER BOARD

- (1) Remove the front panel. (Refer to 2.)
- (2) Remove the room temp. thermistor TH1. (see Photo 3)
- (3) Remove the electrical box covers (screw 4 × 12). (See Photo 3)
- (4) Disconnect the connectors on the indoor controller board.
- (5) Remove the switch board cover.
- (6) Pull out the indoor controller board toward you, then disconnect the rest of connectors.
Remove the indoor controller board and switch board.
- (7) Remove the holder of wireless controller board.
- (8) Disconnect the connector of wireless controller board and remove the wireless controller board from the holder.

Photo 5 Screw of electrical box side cover & clamp

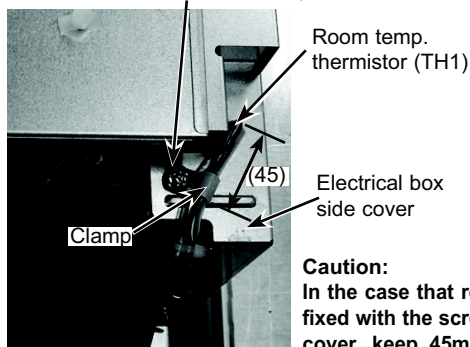

Caution:

In the case that room temp. thermistor is fixed with the screw of electrical box side cover, keep 45mm (1-3/4 inch) between the bottom end of clamp and the top of room temp. thermistor as Photo 5.

4. REMOVING THE ELECTRICAL BOX

- (1) Remove the front panel. (Refer to 2.)
- (2) Remove the electrical box covers. (See Photo 3)
- (3) Remove the nozzle assembly. (Refer to 5.)
- (4) Disconnect the connecting wire from terminal block (TB4) and terminal block for MA-remote controller (TB5, only PKA-A-HA).
- (5) Disconnect the connectors on the indoor controller board.
- (6) Disconnect the connector for the ground wire. (See Photo 6)
- (7) Pull the disconnected lead wire out from the electrical box.
- (8) Remove the screw of electrical box. (See Photo 7)
- (9) Push up the upper fixture (See Photo 6) catch to remove the box, then pull the right fixture (See Photo 4) and remove it from the box fixture.

PHOTOS

Photo 3

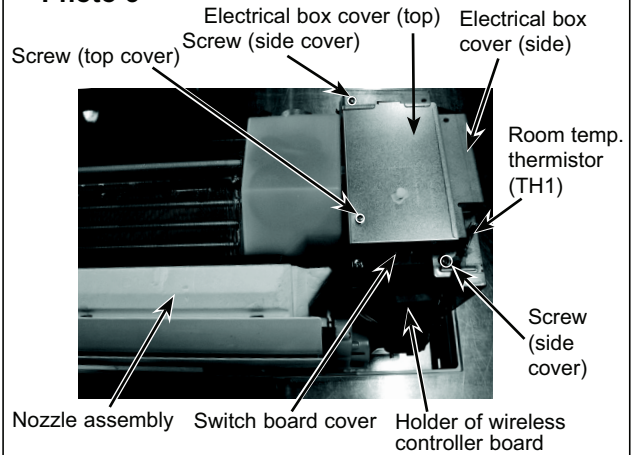

Photo 4

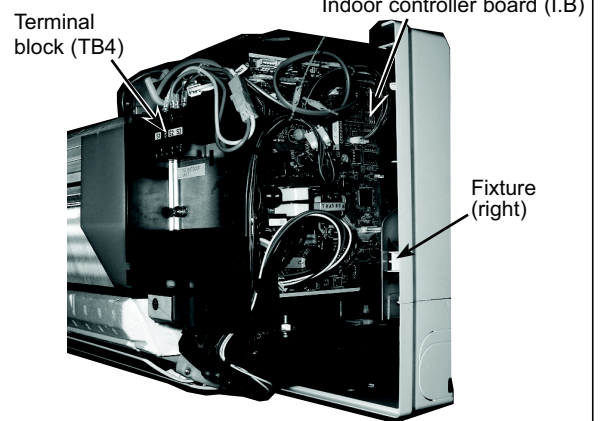

Photo 6

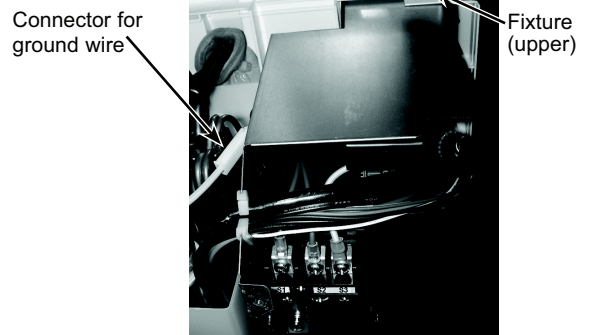
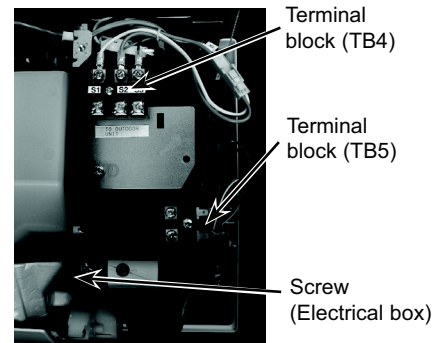

Photo 7



OPERATION PROCEDURE

5. REMOVING THE NOZZLE ASSEMBLY (with VANE and VANE MOTOR) AND DRAIN HOSE

- (1) Remove the front panel (Refer to 2.).
- (2) Remove the electrical box cover.
- (3) Disconnect the vane motor connector (CN151) on the indoor controller board.
- (4) Remove the corner box.
- (5) Pull the nozzle assembly and detach.
- (6) Push the fixture and remove the drain hose.

6. REMOVING THE INDOOR FAN MOTOR AND THE LINE FLOW FAN

- (1) Remove the front panel (Refer to 2.) and the corner box at right lower side.
- (2) Remove the electrical box (Refer to 4.) and the nozzle assembly (Refer to 5.).
- (3) Remove the screws fixing the motor bed. (See Photo 9)
- (4) Loosen the screw fixing the line flow fan. (See Photo 10)
- (5) Remove the motor bed together with fan motor and motor band.
- (6) Release the hooks of the motor band. Remove the motor band. Pull out the indoor fan motor.
- (7) Remove the screws fixing the left side of the heat exchanger. (See Photo 11)
- (8) Lift the heat exchanger, and pull out the line flow fan to the lower-left.

Photo 11

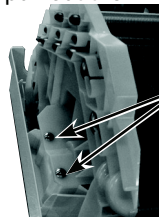

Screw of the left side of the heat exchanger

7. REMOVING THE VANE MOTOR

- (1) Remove the nozzle assembly. (Refer to 5.)
- (2) Remove the screws of the vane motor unit, and pull out the vane motor unit.
- (3) Remove the screws of the vane motor unit cover.
- (4) Remove the vane motor from the vane motor unit.
- (5) Disconnect the connector from the vane motor.

PHOTOS

Photo 8

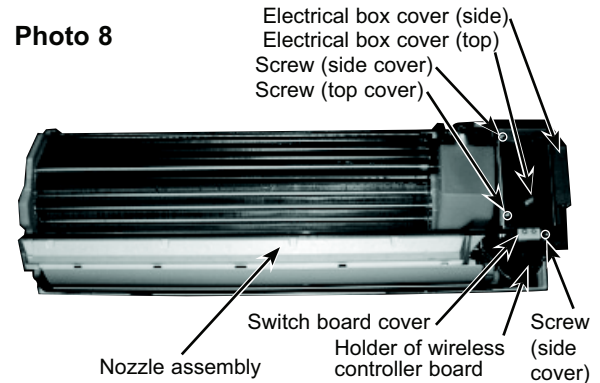

Photo 9

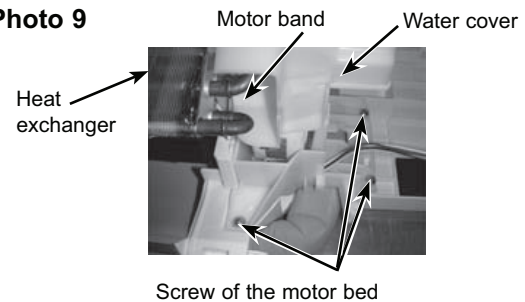

Photo 10

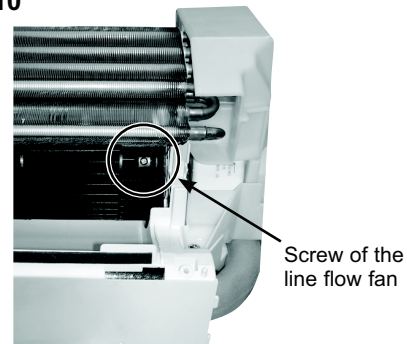
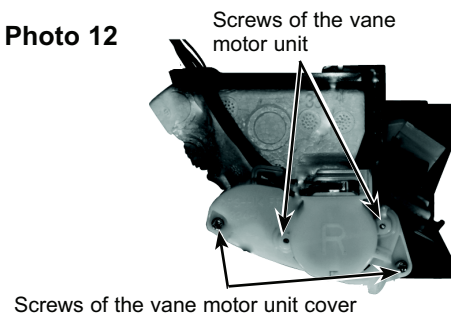

Photo 12





OPERATION PROCEDURE

PHOTOS

8. REMOVING THE LIQUID PIPE THERMISTOR AND COND/EVA TEMP. THERMISTOR

- (1) Remove the front panel. (Refer to 2)
- (2) Remove the electrical box cover.
- (3) Remove the motor band.
- (4) Cut the wiring fixed band.
- (5) Remove the liquid pipe thermistor and cond/eva temp. thermistor.
- (6) Disconnect the connector (CN44) on the indoor controller board.

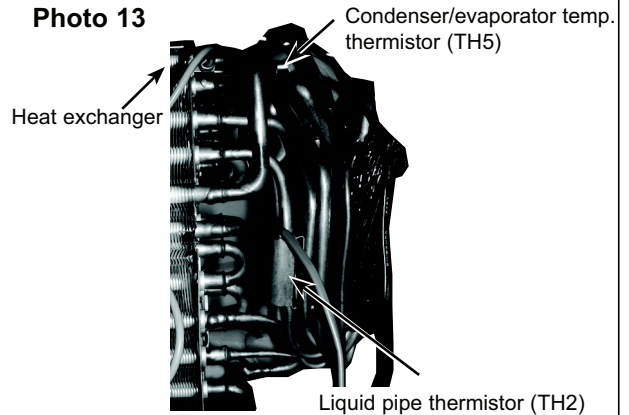

9. REMOVING THE HEAT EXCHANGER

- (1) Remove the front panel (Refer to 2.) and the corner panel at right lower side.
- (2) Remove the electrical box (Refer to 4.) and the nozzle assembly (Refer to 5.).
- (3) Remove the motor band.
- (4) Remove the pipe thermistors (Refer to 8.).
- (5) Disconnect the connector (CN60) on the indoor controller board and the connector for ground wire. (See Photo 6)
- (6) Remove the screws fixing the left side of the heat exchanger. (See Photo 10)
- (7) Remove the heat exchanger.

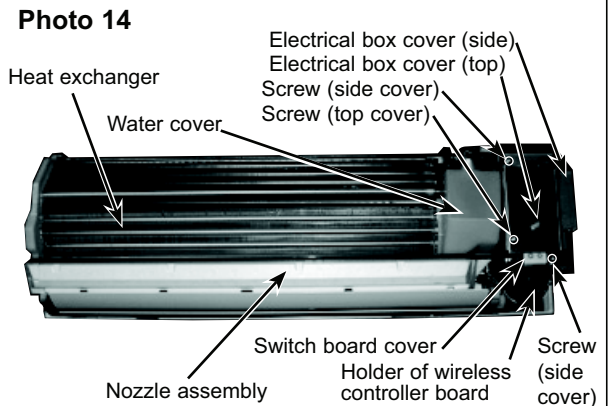

10. REMOVING THE ROOM TEMPERATURE THERMISTOR

- (1) Remove the front panel (Refer to 2.).
- (2) Remove the electrical box cover.
- (3) Remove the room temperature thermistor.
- (4) Disconnect the connector (CN20) on the indoor controller board.

NOTE: When room temp. thermistor is replaced, be sure to use service parts No. R01 N20 202.

