

## SUBMITTAL DATA: MSY-GL18NA-U1 & MUY-GL18NA-U1

### 18,000 BTU/H WALL-MOUNTED AIR-CONDITIONING SYSTEM

Job Name:	Location:	Date:
Purchaser:	Engineer:	
Submitted to:	For <input type="checkbox"/> Reference <input type="checkbox"/> Approval <input type="checkbox"/> Construction	
System Designation:	Schedule No.:	



Indoor Unit: MSY-GL18NA-U1



Wireless Remote Controller



Outdoor Unit: MUY-GL18NA-U1

**ACCESSORIES:**
**Indoor Unit**

Anti-Allergy Enzyme Filter (MAC-408FT-E)

**Outdoor Unit**

Windscreens (ME-FR-24)

**Controls**

Wireless Controller (MHK2)

Wired Remote Controller PAR-40MAA (Requires MAC-334IF-E)

Thermostat Interface (PAC-US444CN-1)

**SPECIFICATIONS:**

Rated Conditions (Capacity / Input)		
Cooling <sup>1</sup>	Btu/h / W	18,000 / 1,340

Capacity Range	Minimum	Maximum
Cooling <sup>1</sup>	Btu/h / W	5,800 / 330
		22,000 / 1,250

**NOTE:** Test conditions are based on AHRI 210/240.

1: Rating conditions (Cooling) — Indoor: 80°FDB, 67°FWB, Outdoor: 95°FDB, (75°FWB)

Operating Conditions (Outdoor Intake Air Temp.) (Max. / Min.)	
Cooling <sup>2</sup>	115 F (46° C) DB / 14° F (-10° C) DB

<sup>2</sup> Applications should be restricted to comfort cooling only; equipment cooling applications are not recommended for low ambient temperature conditions.

AHRI Efficiency Ratings	
SEER [ SEER2 ] / EER	20.5 [20.5] / 13.4

Energy Star <sup>®</sup>	Yes
--------------------------	-----

ENERGY STAR products are third-party certified by an EPA-recognized Certification Body.

Electrical Power Requirements	208 / 230V, 1-Phase, 60 Hz
-------------------------------	----------------------------

Minimum Circuit Ampacity (MCA) *		
Indoor / Outdoor (RBS)	A	1 / 14 (15A - Recommended Breaker Size)

\* All electrical work shall comply with National (CEC) and local codes and regulations.

Indoor Unit		
Blower Motor (ECM)	F.L.A.	0.76
Blower Motor Output	W	30
SHF / Moisture Removal		0.870 / 2.1 pt./h
Field Drainpipe Size O.D.	In.(mm)	5/8 (15)

Outdoor Unit		
Compressor		DC INVERTER-driven Twin Rotary
Fan Motor (ECM)	F.L.A.	0.93

Airflow Rate (Quiet - Lo - Med - Hi - Super Hi)			
Indoor	DRY	CFM (L/sec)	258-332-417-522-646 (122-157-246-305)
	WET		232-299-375-470-581 (109-141-177-274)
Outdoor			922 / 1742 (435 / 822)

Sound Pressure Level (Quiet - Lo - Med - Hi - Super Hi)			
Indoor	Cooling	dB(A)	28-33-38-44-49
Outdoor	Cooling		54

External Dimensions		
Indoor (H x W x D)	In.(mm)	12 x 36-5/16 x 9-13/16 (305 x 923 x 250)
Outdoor (H x W x D)		34-5/8 x 33-1/16 x 13 (880 x 840 x 330)

Net Weight		
Indoor	Lbs.(kg)	28 (13)
Outdoor		121 (55)

External Finish	
Indoor	Munsell 1.0Y 9.2 / 0.2
Outdoor	Munsell No. 3Y 7.8 / 1.1

Refrigerant	R410A; 3 lb. 9 oz.
-------------	--------------------

Refrigerant Piping (Flared)		
Liquid (High Pressure)	In.(mm)	1/4 (6.35)
Gas (Low Pressure)		1/2 (12.7)
Max. Total Refrigerant Pipe Length (Height Diff.)	Ft. (m)	50 (15)
Max. Total Refrigerant Pipe Length (Length.)		100 (30)

Specifications are subject to change without notice

# DIMENSIONS: MSY-GL18NA-U1 & MUY-GL18NA-U1

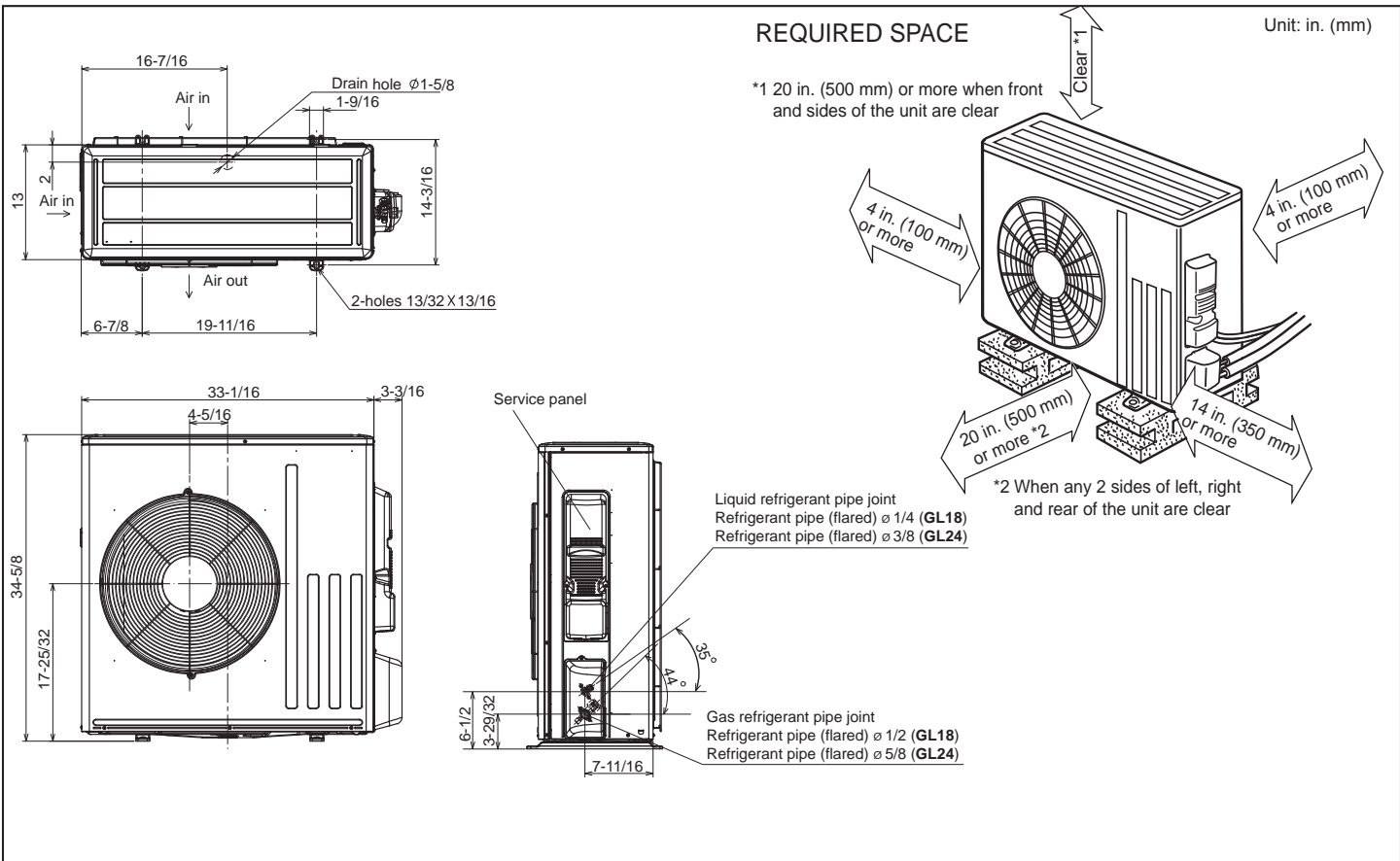
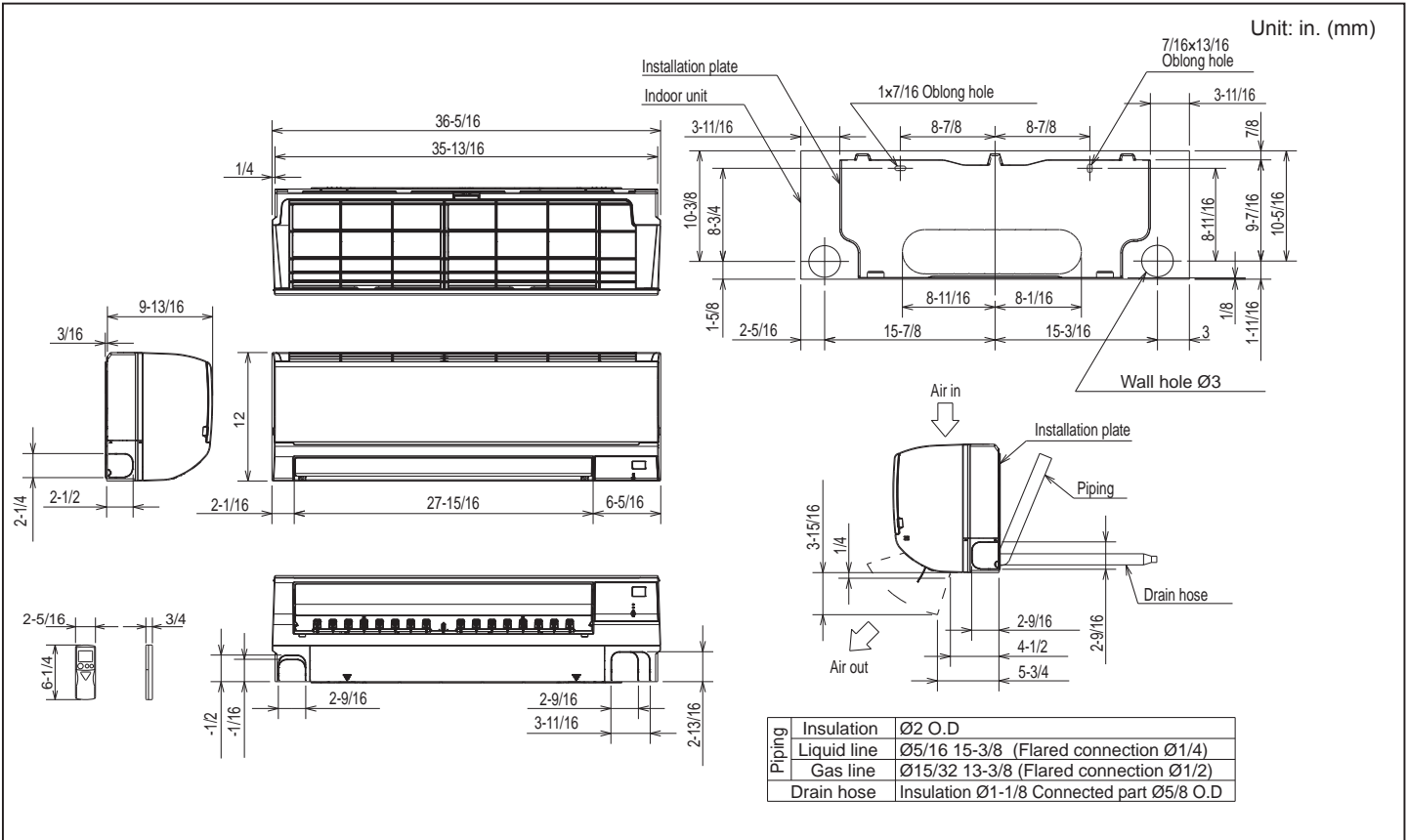

Should this document be altered or changed without MESCA's permission, it becomes null and void. MESCA assumes no responsibility for any consequences in such cases.



Form # SB\_MSY-GL18NA-U1\_MUY-GL18NA-U1\_202210  
 Specifications are subject to change without notice.  
 www.MitsubishiElectric.ca  
 © 2018 Mitsubishi Electric Sales Canada Inc.