

SUBMITTAL DATA: PKA-A18HA7 & PUZ-A18NKA7
18,000 BTU/H WALL-MOUNTED HEAT PUMP SYSTEM

Job Name:	Engineer:
Purchaser:	Application:
Submitted To:	For: <input type="checkbox"/> Reference <input type="checkbox"/> Approval <input type="checkbox"/> Construction
Submitted By:	Location:
System Designation:	Schedule No.:



Indoor Unit: PKA-A18HA7



Outdoor Unit: PUZ-A18NKA7 (-BS)

UNIT OPTION:

Standard Model.....PUZ-A18NKA7
Seacoast (BS) Model.....PUZ-A18NKA7-BS

ACCESSORIES:

Indoor

Controls

External Heater Adaptor (PAC-SE59RA-E)

- Wireless Controller (MHK1)
- Advanced Wired Controller (PAR-40MAA)
- Simple Wired Controller (PAC-YT53CRAU)
- Wireless Remote Controller (PAR-FL32MA) Thermostat
- Interface (PAC-US444CN)
- M-NET Adapter (PAC-SJ96MA-E)

Outdoor Unit

- Front Wind Guard (PFR-12-18)
- Rear Wind Guard (PRE-12-18)
- Side Wind Guard (PSD-12-18)

Note: Mitsubishi Electric (MESCA) supports the use of only MESCA supplied and approved Snow Guard / Wind Deflectors / Windscreens and accessories for proper functioning of the unit(s). Use of non-MESCA supported Snow Guard / Wind Deflectors / Windscreens and accessories will affect warranty coverage.

SPECIFICATIONS:

Rated Conditions (Capacity / Input)*		
Cooling	Btu/h / W	18,000 / 1,820
Heating at 47° F	Btu/h / W	19,000 / 1,300
Heating at 17° F	Btu/h / W	11,300 / 1,340

* Rating Conditions per AHRI Standard:
Cooling | Indoor: 80° F (27° C)DB / 67° F (19° C)WB; Outdoor: 95° F (35° C)DB / 75° F (24° C)WB
Heating at 47° F | Indoor: 70° F (21° C)DB / 60° F (16° C)WB; Outdoor: 47° F (8° C)DB / 43° F (6° C)WB
Heating at 17° F | Indoor: 70° F (21° C)DB / 60° F (16° C)WB; Outdoor: 17° F (-8° C)DB / 15° F (-9° C)WB

Capacity Range		
Cooling	Btu/h	8,000 - 18,000
Heating at 47° F	Btu/h	7,700 - 22,000

Operating Range	
Cooling	0°F** (-18°C) to 115°F (46°C) DB
Heating	12°F (-11°C) to 70°F (21°C) DB

** Windscreens required for cooling operation below 23°F (-5°C)

AHRI Efficiency Ratings	
EER	9.9
SEER	18.5
HSPF IV / V	10.2 / 7.5
COP at 47° F	4.28
COP at 17° F	2.47

Specifications are subject to change without notice.

Electrical Power Requirements	208 / 230V, 1-Phase, 60 Hz
-------------------------------	----------------------------

Minimum Circuit Ampacity (MCA) *		Breaker Size	MOCP (Outdoor)
Indoor 1 AMP	Outdoor 11 AMP	15 AMP	28 AMP

***All electrical work shall comply with National (CEC) and local codes and regulations.**

Indoor Unit		
Fan Motor (ECM)	F.L.A.	0.33
Fan Motor Output	W	30
SHF / Moisture Removal		0.68 / 5.2 pt./h
Field Drainpipe Size O.D	in. (mm)	5/8 (16)

Outdoor Unit		
Compressor		DC INVERTER-driven Twin Rotary
Fan Motor (ECM)	F.L.A.	0.5
Fan Motor Power	W	46

Airflow Rate (Low-Mid-Hi)			
Indoor (Cooling)	DRY	CFM	320-370-425
	WET		290-335-380
Outdoor	DRY		1,590

Sound Pressure Level		
Indoor (Low-Mid-Hi)		36-40-43
Outdoor	Cooling	44
	Heating	46

External Dimensions		
Indoor (H x W x D)	In.(mm)	11-5/8 x 35-3/8 x 9-13/16 (295 x 898 x 249)
Outdoor (H x W x D)		24-13/16 x 31-13/16 + 7/16 x 11-3/16 (630 x 809 + 62 x 300)

Net Weight	
Indoor	Lbs.(kg)
Outdoor	29 (13) 100 (45)

External Finish	
Indoor	White Munsel No. 1.0Y 9.2/0.2
Outdoor	Ivory Munsell No. 3Y 7.8 / 1.1

Refrigerant	R410A ; 4lbs., 14oz. (2.2kg)
-------------	------------------------------

Refrigerant Piping (Flared)		
Liquid (High Pressure)	In.(mm)	1/4 (6.35)
Gas (Low Pressure)		1/2 (12.7)
Maximum Total Refrigerant Pipe Length	Ft. (m)	100 (30)
Maximum Vertical Separation	Ft. (m)	100 (30)

Should this document be altered or changed without MESCA's permission, it becomes null and void. MESCA assumes no responsibility for any consequences in such cases.

DIMENSIONS: PKA-A18HA7

Unit: in. (mm)

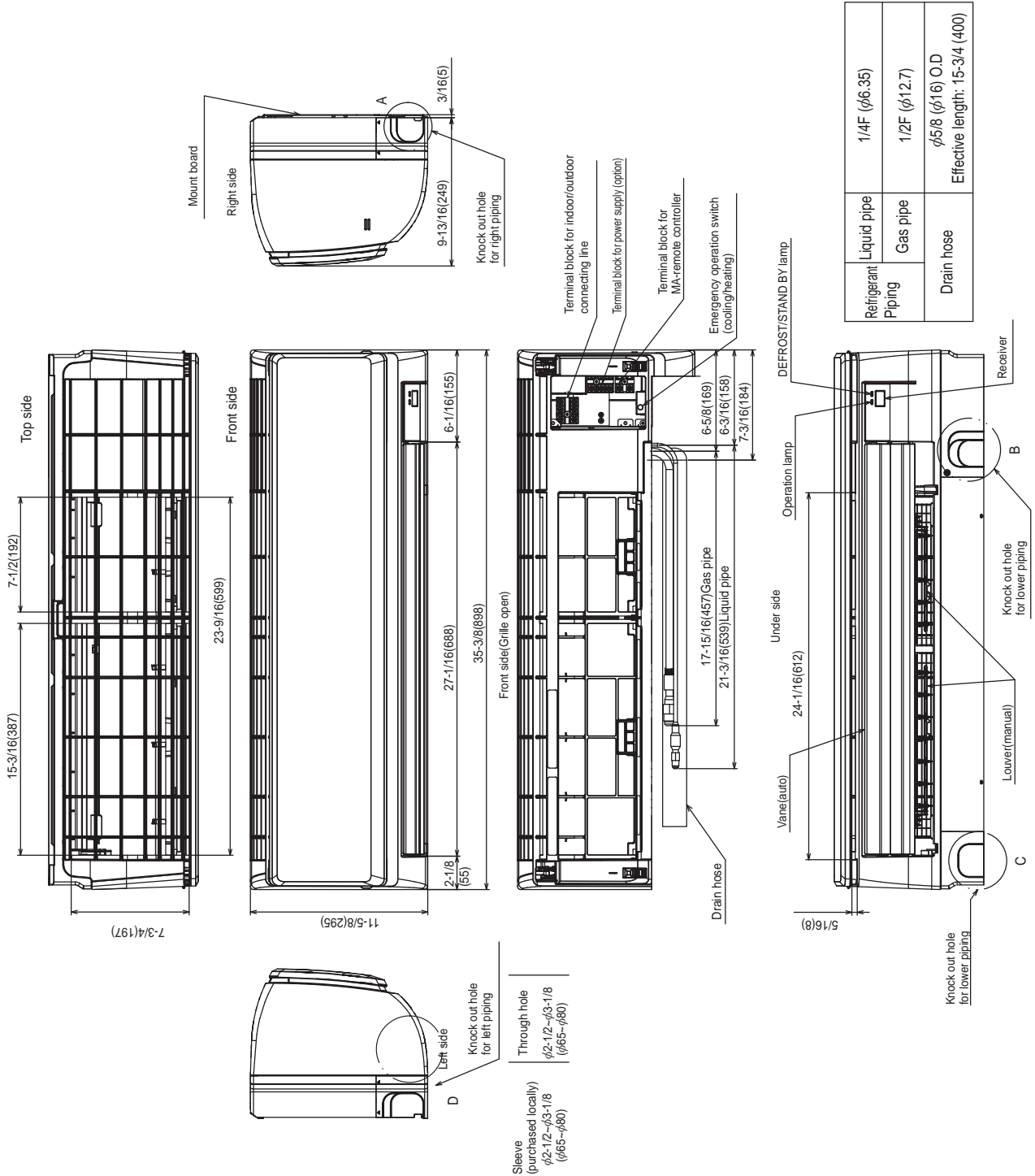

Specifications are subject to change without notice.

Should this document be altered or changed without MESCA's permission, it becomes null and void. MESCA assumes no responsibility for any consequences in such cases.

DIMENSIONS: PUZ-A18NKA7

Should this document be altered or changed without MESCO's permission, it becomes null and void. MESCO assumes no responsibility for any consequences in such cases.

Unit: mm (in.)

Free space around the outdoor unit
(basic example)

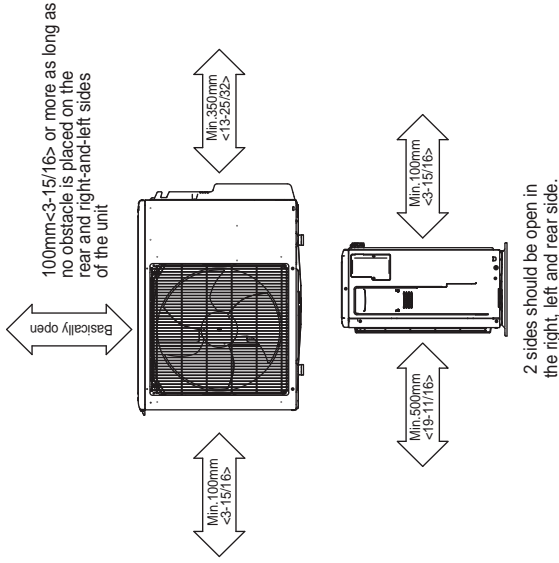

FOUNDATION BOLTS

Please secure the unit firmly with 4 foundation (M10<W3/8>) bolts. (Bolts, washers and nut must be purchased locally).

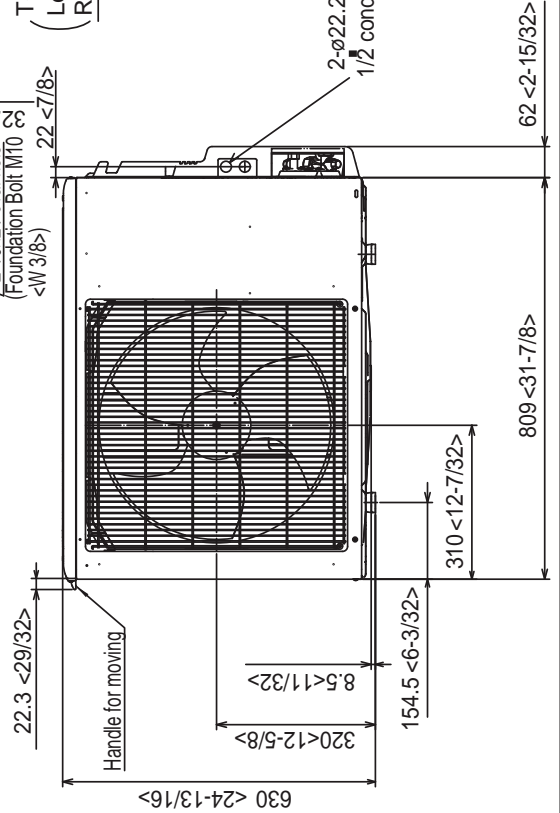
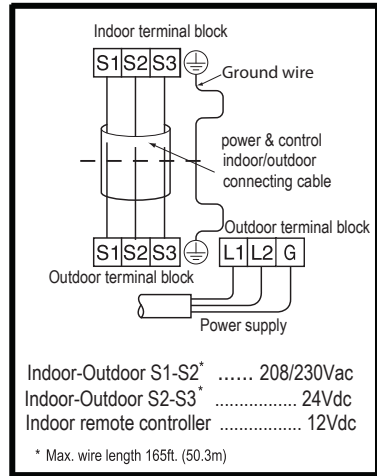
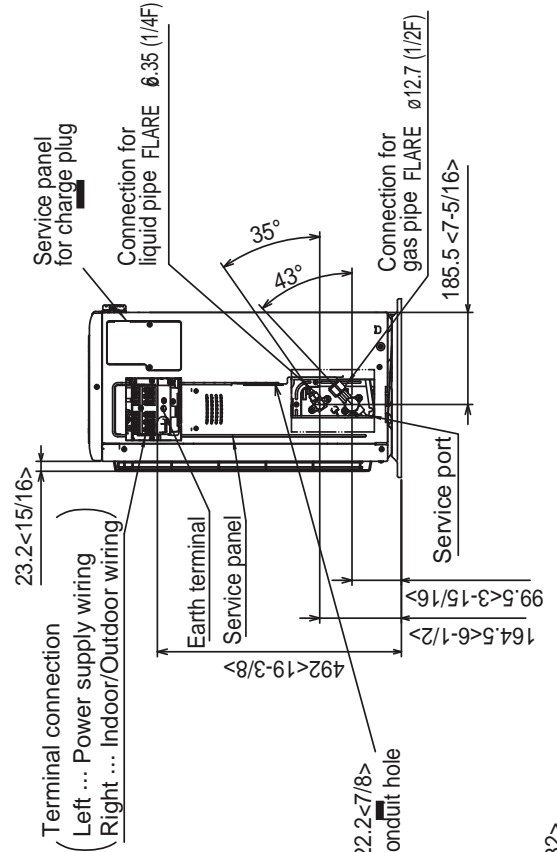
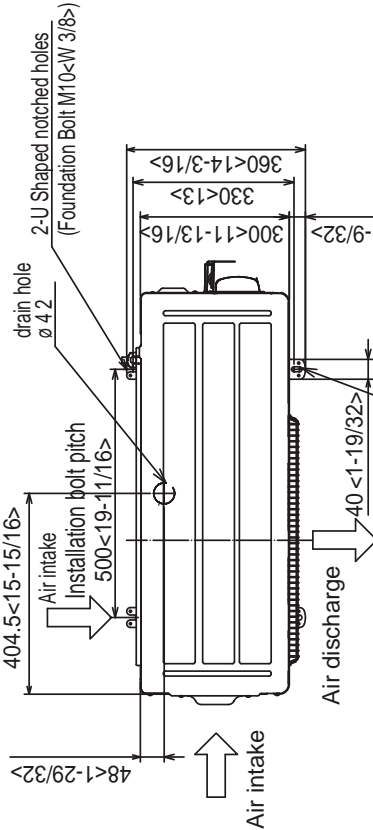
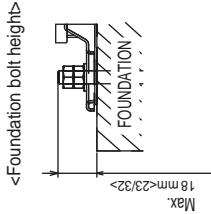

for a greener tomorrow

