

**SUBMITTAL DATA: PLA-A12EA7R1-TH & PUY-A12NKA7**  
12,000 BTU/H CEILING CASSETTE AIR-CONDITIONING SYSTEM

Job Name:	Engineer:
Purchaser:	Application:    Std. Cooling            Ultra Low Ambient Cooling
Submitted To:	For: <input type="checkbox"/> Reference <input type="checkbox"/> Approval <input type="checkbox"/> Construction
Submitted By:	Location:
System Designation:	Schedule No.:



**ACCESSORIES:**

**Indoor Unit**

Multifunction Casement / High Efficiency Filter (PAC-SJ41TM-E / PAC-SH59KF-E)  
Grille with 3D i-see Sensor™ (PLP-41EAEU) - (Required ordered separately)

**Optional Controls**

- Wireless Controller (MHK1)
- Advanced Wired Controller (PAR-40MAA)
- Simple Wired Controller (PAC-YT53CRA)
- Thermostat Interface (PAC-US444CN)
- Wireless Remote Controller (PAR-FL32MA)(Requires Signal Receiver (PAR-SR4LU-E))
- M-NET Adapter (PAC-SJ96MA-E)

**Outdoor Unit**

- Front Wind Guard (PFR-12-18)
- Rear Wind Guard (PRE-12-18)
- Side Wind Guard (PSD-12-18)

**Note: Mitsubishi Electric (MESCA) supports the use of only MESCA supplied and approved Snow Guard / Wind Deflectors / Windscreens and accessories for proper functioning of the unit(s). Use of non-MESCA supported Snow Guard / Wind Deflectors / Windscreens and accessories will affect warranty coverage.**

**SPECIFICATIONS:**

Rated Conditions (Capacity / Input)*		
Cooling	Blu/h / W	12,000 / 730

\* Rating Conditions per AHRI Standard:  
Cooling | Indoor: 80°F (27°C) DB / 67°F (19°C) WB  
Cooling | Outdoor: 95°F (35°C) DB / 75°F (24°C) WB

Capacity Range		
Cooling	Blu/h	5,800 - 12,000

Operating Range		
Cooling		-40F** (-40.0°C) to 115°F (46°C) DB

\*\* Windscreens required for cooling operation below 23°F (-5°C)

AHRI Efficiency Rating	
EER	16.4
SEER	27.0

Electrical Power Requirements	
	208 / 230V, 1-Phase, 60 Hz

Minimum Circuit Ampacity (MCA) *		Breaker Size	MOCP (Outdoor)
Indoor 1 AMP	Outdoor 11 AMP	15 AMP	28 AMP

**\*All electrical work shall comply with National (CEC) and local codes and regulations.**

Indoor Unit		
Fan Motor (ECM)	F.L.A.	0.26
Fan Motor Output	W	50
SHF / Moisture Removal		0.89 / 1.2 pt./h
Drain Lift Mechanism (Included)	H: In.	33-7/16
Field Drainpipe Size O.D.	In.(mm)	1-1/4 (32)

Outdoor Unit		
Compressor		DC INVERTER-driven Twin Rotary
Fan Motor (ECM)	F.L.A.	0.5
Fan Motor Power	W	46

Airflow Rate (Low-M1-M2-Hi)			
Indoor (Cooling)	DRY	CFM	420-460-490-530
	WET		380-420-450-490
Outdoor	DRY		1,590

Sound Pressure Level		
Indoor (Low-M1-M2-Hi)	dB(A)	27-28-29-30
Outdoor    Cooling		44

External Dimensions			
Indoor (H x W x D)	In.(mm)	10-3/16 [1-9/16] x 33-1/16 [37-13/32] x 33-1/16 [37-13/32]	
Grille ([H x W x D])		(258 [40] x 840 [950] x 840 [950])	
Outdoor (H x W x D)		24-13/16 x 31-13/16 + 7/16 x 11-3/16 (630 x 809 + 62 x 300)	

Net Weight		
Indoor (Unit / Grille)	Lbs.(kg)	46 / 11 (21 / 5)
Outdoor		92 (41)

External Finish	
Indoor	Munsell 1.0Y 9.2/0.2
Outdoor	Ivory Munsell No. 3Y 7.8 / 1.1

Refrigerant	R410A ; 4lbs., 7oz. (2.0kg)
-------------	-----------------------------

Refrigerant Piping (Flared)		
Liquid (High Pressure)	In.(mm)	1/4 (6.35)
Gas (Low Pressure)		1/2 (12.7)
Maximum Total Refrigerant Pipe Length	Ft. (m)	165 (50)
Maximum Vertical Separation	Ft. (m)	100 (30)

# DIMENSIONS: PLA-A12EA7R1-TH

Unit: in. (mm)

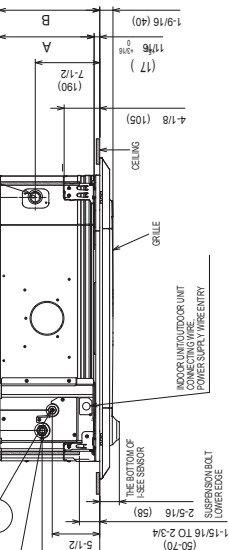
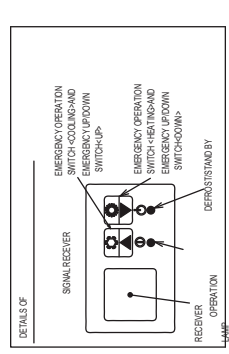
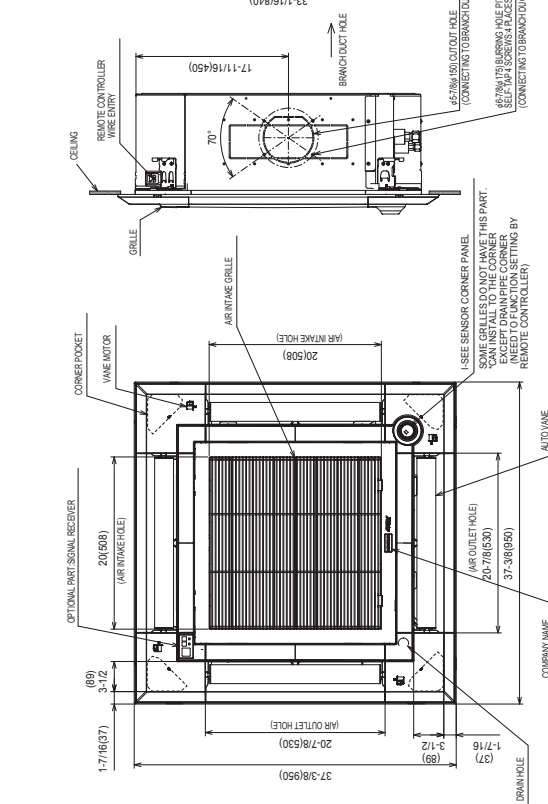
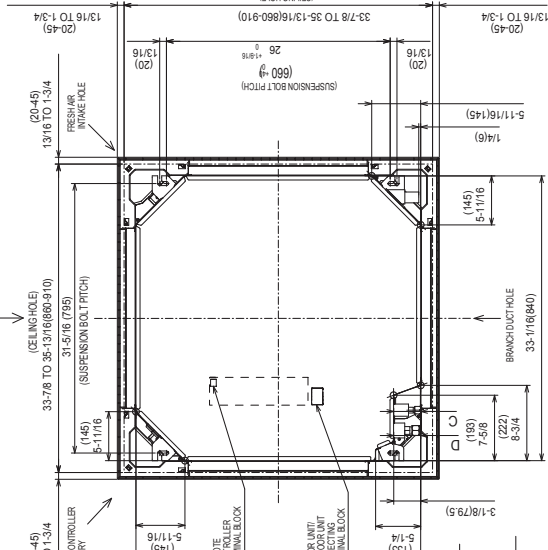
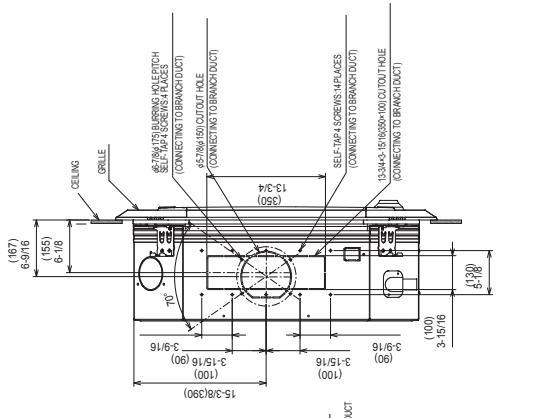
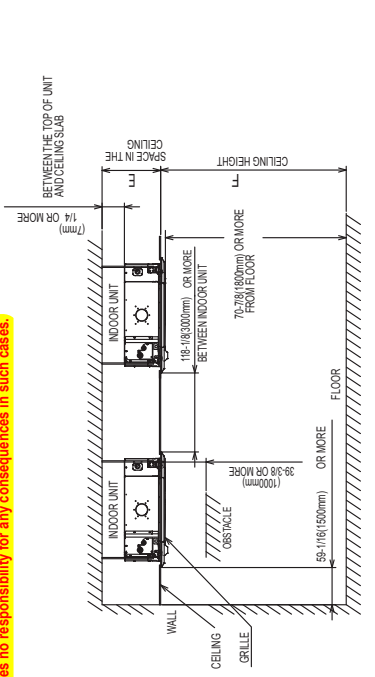
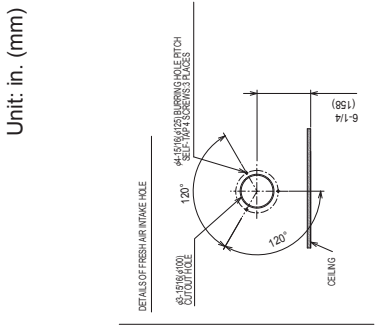

1. CHOOSE THE GRILLE AMONG THE DEDICATED GRILLES.
  2. REINFORCE THE SUSPENSION BOLT FOR EARTHQUAKE RESISTANCE AS NEEDED.
  3. FOR THE SUSPENSION BOLT, USE M10 OR W3/8. (PROCURED AT THE LOCAL SITE.)
  4. FOR DRAIN PIPE, USE VP-25(O.D. 1-1/4"(32) PVC TUBE). DRAIN PUMP INCLUSION. RAISE IS MAX 33-7/16"(850mm) FROM THE CEILING.
  5. ELECTRICAL BOX MAY BE REMOVED FOR THE SERVICE PURPOSE.
- MAKE SURE TO SLACK THE ELECTRICAL WIRE LITTLE BIT FOR CONTROL/POWER WIRES CONNECTION.
6. THE HEIGHT OF THE INDOOR UNIT IS ABLE TO BE ADJUSTED WITH THE GRILLE ATTACHED.
  7. REQUIRES "E" OR MORE SPACE BETWEEN TRANSOM AND CEILING FOR THE INSTALLATION.
  8. WHEN INSTALLING THE BRANCH DUCTS, BE SURE TO INSULATE ADEQUATELY.
  9. OTHERWISE CONDENSATION AND DRIPPING MAY OCCUR (IT BECOMES THE CAUSE OF DROPLET OR DRIPLETT DRIPPING).
  10. FOR THE INSTALLATION OF THE OPTIONAL HIGH EFFICIENCY FILTER OR MULTI-FUNCTIONAL CASEMENT, REFER TO SPECIAL DRAWING.

MODELS	A	B	C	D	E	F
PLA-A12/18EA7	9-1/2 (241)	10-3/16 (268)	3/8 (9.5)	10-7/16 (268) OR MORE	10-7/16 (268) OR MORE	10-7/16 (268) OR LESS
PLA-A24~42EA7	11-1/8 (288)	11-3/4 (298)	3-1/8 (79.5)	12-3/8 (320) OR MORE	12-3/8 (320) OR MORE	12-3/8 (320) OR LESS

# DIMENSIONS: PUY-A12NKA7

Should this document be altered or changed without MESCO's permission, it becomes null and void. MESCO assumes no responsibility for any consequences in such cases.

Unit: mm (in.)

## Free space around the outdoor unit (basic example)

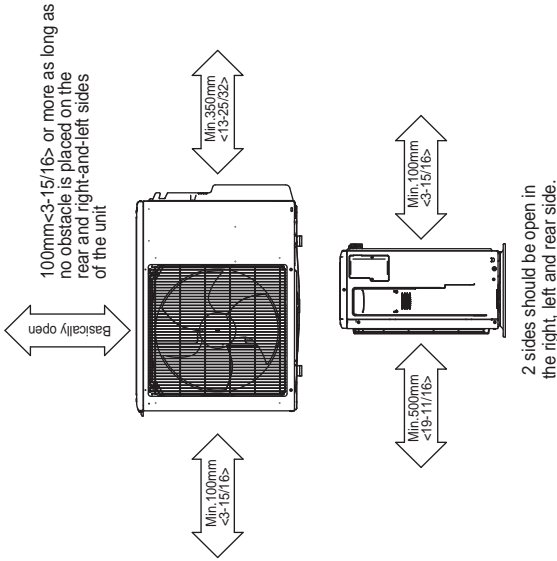

## FOUNDATION BOLTS

Please secure the unit firmly with 4 foundation (M10<math><W3/8></math>) bolts. (Bolts, washers and nut must be purchased locally).

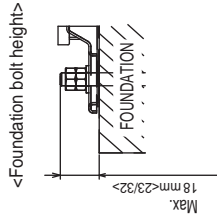

2-U Shaped notched holes  
(Foundation Bolt M10<math><W3/8></math>)

