

SUBMITTAL DATA: PLA-A36EA7R1-TH & PUZ-A36NKA7
36,000 BTU/H CEILING CASSETTE HEAT PUMP SYSTEM

Job Name:	Engineer:
Purchaser:	Application:
Submitted To:	For: <input type="checkbox"/> Reference <input type="checkbox"/> Approval <input type="checkbox"/> Construction
Submitted By:	Location:
System Designation:	Schedule No.:



ACCESSORIES:

Indoor Unit

- Multifunction Casement / High Efficiency Filter (PAC-SJ41TM-E / PAC-SH59KF-E)
- Grille with 3D i-see Sensor™ (PLP-41EAEU) - (Required ordered separately)
- External Heater Adaptor (PAC-SE56RA-E)

Optional Controls

- Wireless Controller (MHK1)
- Advanced Wired Controller (PAR-40MAA)
- Simple Wired Controller (PAC-YT53CRA)
- Thermostat Interface (PAC-US444CN)
- Wireless Remote Controller (PAR-FL32MA)(Requires Signal Receiver (PAR-SR4LU-E))
- M-NET Adapter (PAC-SJ95MA-E)

Outdoor Unit

- Front Wind Deflector (x2 required) (CM-S-FR-NKMU) Rear Snow Guard (SG-1-RE)
- Front Wind Blocker (x2 per box) (CM-S-BLK-NKMU) Side Snow Guard (SG-1-SD)

Note: Mitsubishi Electric (MESCA) supports the use of only MESCA supplied and approved Snow Guard / Wind Deflectors / Windscreens and accessories for proper functioning of the unit(s). Use of non-MESCA supported Snow Guard / Wind Deflectors / Windscreens and accessories will affect warranty coverage.

SPECIFICATIONS:

Rated Conditions (Capacity / Input)*		
Cooling	Btu/h / W	36,000 / 2,780
Heating at 47°F	Btu/h / W	38,000 / 2,540
Heating at 17°F	Btu/h / W	22,000 / 2,490

* Rating Conditions per AHRI Standard:
Cooling | Indoor: 80°F (27°C) DB / 67°F (19°C) WB; Outdoor: 95°F (35°C) DB / 75°F (24°C) WB
Heating at 47°F | Indoor: 70°F (21°C) DB / 60°F (16°C) WB; Outdoor: 47°F (8°C) DB / 43°F (6°C) WB
Heating at 17°F | Indoor: 70°F (21°C) DB / 60°F (16°C) WB; Outdoor: 17°F (-8°C) DB / 15°F (-9°C) WB

Capacity Range		
Cooling	Btu/h	16,000 - 36,000
Heating at 47°F	Btu/h	18,000 - 42,000

Operating Range	
Cooling	0°F** (-18°C) to 115°F (46°C) DB
Heating	-4°F (-20°C) to 70°F (21°C) DB

** Windscreens required for cooling operation below 23°F (-5°C)

AHRI Efficiency Ratings	
EER	12.9
SEER	21.8
HSPF IV / V	10.4 / 7.6
COP at 47° F	4.38
COP at 17° F	2.58

Specifications are subject to change without notice.

Electrical Power Requirements	208 / 230V, 1-Phase, 60 Hz
-------------------------------	----------------------------

Minimum Circuit Ampacity (MCA) *	Breaker Size	MOCP (Outdoor)
Indoor 2 AMP	Outdoor 25 AMP	30 AMP / 31 AMP

* All electrical work shall comply with National (CEC) and local codes and regulations.

Indoor Unit		
Fan Motor (ECM)	F.L.A.	0.98
Fan Motor Output	W	120
SHF / Moisture Removal		0.86 / 4.5 pt./h
Drain Lift Mechanism (Included)	H: In.	33-7/16
Field Drainpipe Size O.D	in. (mm)	1-1/4 (32)

Outdoor Unit		
Compressor		DC INVERTER-driven Twin Rotary
Fan Motor (ECM)	F.L.A.	0.5+0.5
Fan Motor Power	W	74

Airflow Rate (Low-M1-M2-Hi)			
Indoor (Cooling)	DRY	CFM	670-850-1020-1200
	WET		630-810-980-1160
Outdoor	DRY		3,880

Sound Pressure Level			
Indoor (Low-M1-M2-Hi)	dB(A)	32-37-41-44	
		Outdoor	Cooling
Heating	53		

External Dimensions		
Indoor (H x W x D) Grille (H x W x D)]	In.(mm)	11-3/4 [1-9/16] x 33-1/16 [37-13/32] x 33-1/16 [37-13/32] (298 [40] x 840 [950] x 840 [950])
Outdoor (H x W x D)		52-11/16 x 41-5/16 x 13 + 1-3/16 (1,338 x 1050 x 330 + 30)

Net Weight		
Indoor (Unit / Grille)	Lbs.(kg)	56 / 11 (25 / 5)
Outdoor		214 (97)

External Finish	
Indoor	Munsell 1.0Y 9.2/0.2
Outdoor	Ivory Munsell No. 3Y 7.8 / 1.1

Refrigerant	R410A ; 10lbs., 6oz. (4.7kg)
-------------	------------------------------

Refrigerant Piping (Flared)		
Liquid (High Pressure)	In.(mm)	3/8 (9.52)
Gas (Low Pressure)		5/8 (15.88)
Maximum Total Refrigerant Pipe Length	Fl. (m)	165 (50)
Maximum Vertical Separation	Fl. (m)	100 (30)

Should this document be altered or changed without MESCA's permission, it becomes null and void. MESCA assumes no responsibility for any consequences in such cases.

DIMENSIONS: PLA-A36EA7R1-TH

Unit: in. (mm)

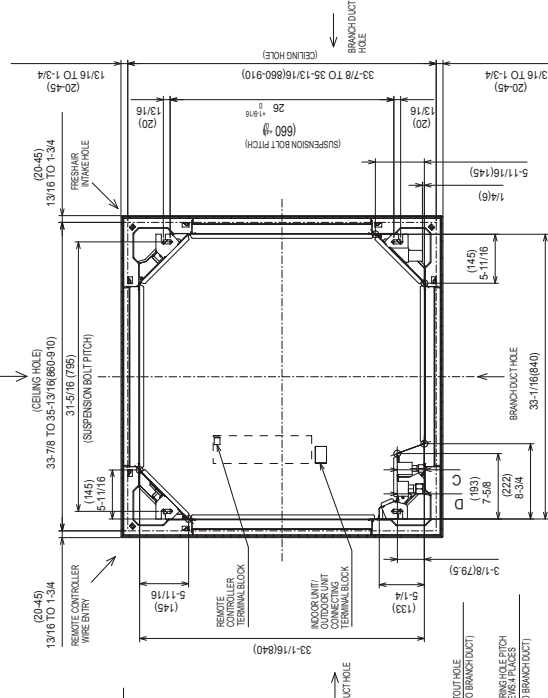
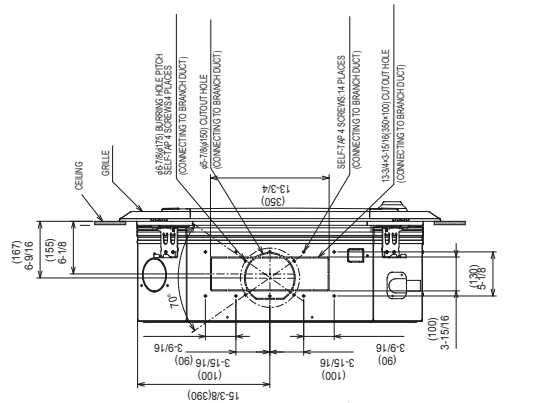
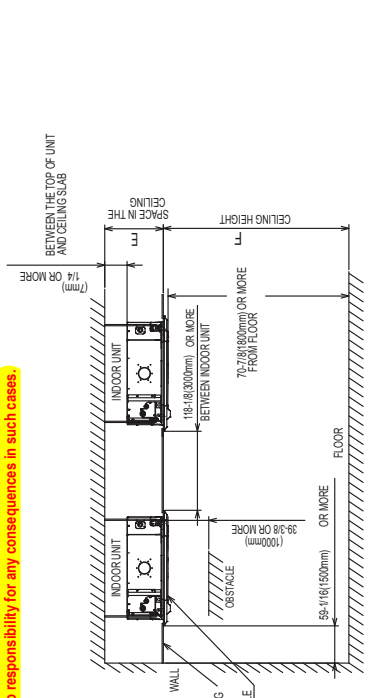
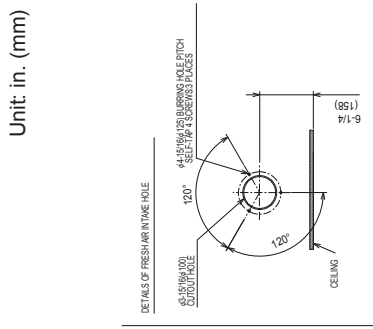

- NOTE1. CHOOSE THE GRILLE AMONG THE DEDICATED GRILLES.
2. REINFORCE THE SUSPENSION BOLT FOR EARTHQUAKE-RESISTANCE AS NEEDED.
3. FOR THE SUSPENSION BOLT, USE M10 OR M8. (PROCURED AT THE LOCAL SITE.)
4. FOR DRAIN PIPE, USE VP-25 (Ø 1-1/4" (Ø 32) PVC TUBE). DRAIN PUMP INCLUSION. RAISE IS MAX 33-7/16" (850mm) FROM THE CEILING.
5. ELECTRICAL BOX MAY BE REMOVED FOR THE SERVICE PURPOSE.

- MAKE SURE TO SLACK THE ELECTRICAL WIRE LITTLE BIT FOR CONTROL/POWER WIRES CONNECTION.
6. THE HEIGHT OF THE INDOOR UNIT IS ABLE TO BE ADJUSTED WITH THE GRILLE ATTACHED.
7. REQUIRES "E" OR MORE SPACE BETWEEN TRANSOM AND CEILING FOR THE INSTALLATION.
8. WHEN INSTALLING THE BRANCH DUCTS, BE SURE TO INSULATE ADEQUATELY.
9. OTHERWISE CONDENSATION AND DRIPPING MAY OCCUR (IT BECOMES THE CAUSE OF DROPLET OR DRIPLET DRIPPING.)
10. AS FOR NECESSARY INSTALLATION/SERVICE SPACE, PLEASE REFER TO THE RIGHT AT FIGURE.
11. FOR THE INSTALLATION OF THE OPTIONAL HIGH EFFICIENCY FILTER OR MULTI-FUNCTIONAL CASEMENT, REFER TO SPECIAL DRAWING.

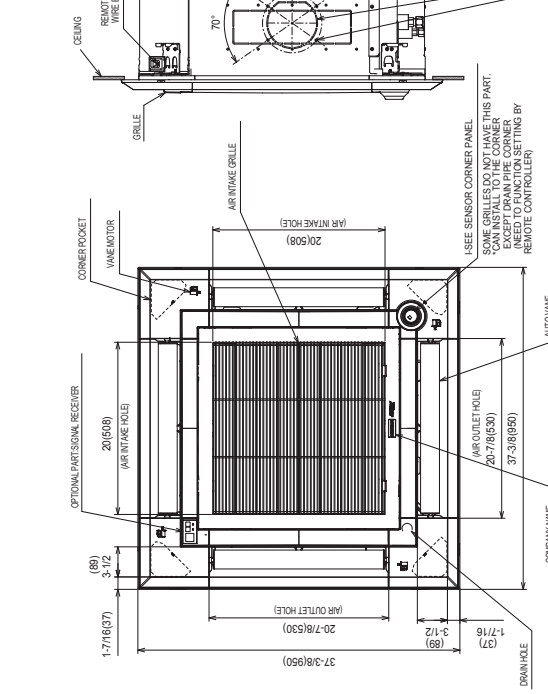

Specifications are subject to change without notice.

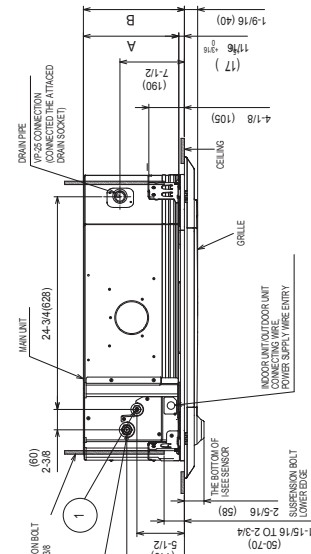
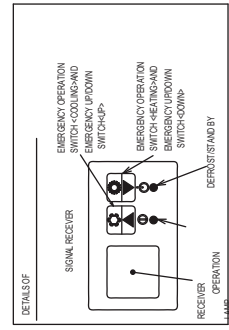

MODELS	①	②	A	B	C	D	E	F
PLA-A12/18EA7	REFRIGERANT PIPES FLARED CONNECTION 1/4"	REFRIGERANT PIPES FLARED CONNECTION 1/2"	9-1/2 (241)	10-3/16 (258)	3(76)	3(76)	10-7/16 (265) OR MORE	137-13/16 (350) OR LESS
PLA-A24~42EA7	REFRIGERANT PIPES 3/8" FLARED CONNECTION 3/8"	REFRIGERANT PIPES 3/8" FLARED CONNECTION 3/4"	11-1/16 (281)	11(28)	3(76)	3(76)	12-3/8 (316) OR MORE	177-3/16 (450) OR LESS

PLA-A36EA7R1-TH

DIMENSIONS: PUZ-A36NKA7

Unit: mm (in.)

Should this document be altered or changed without MESCO's permission, it becomes null and void. MESCO assumes no responsibility for any consequences in such cases.

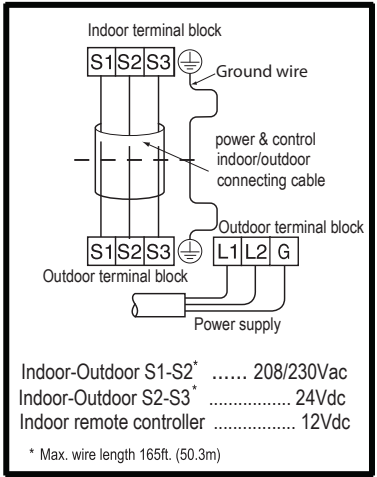
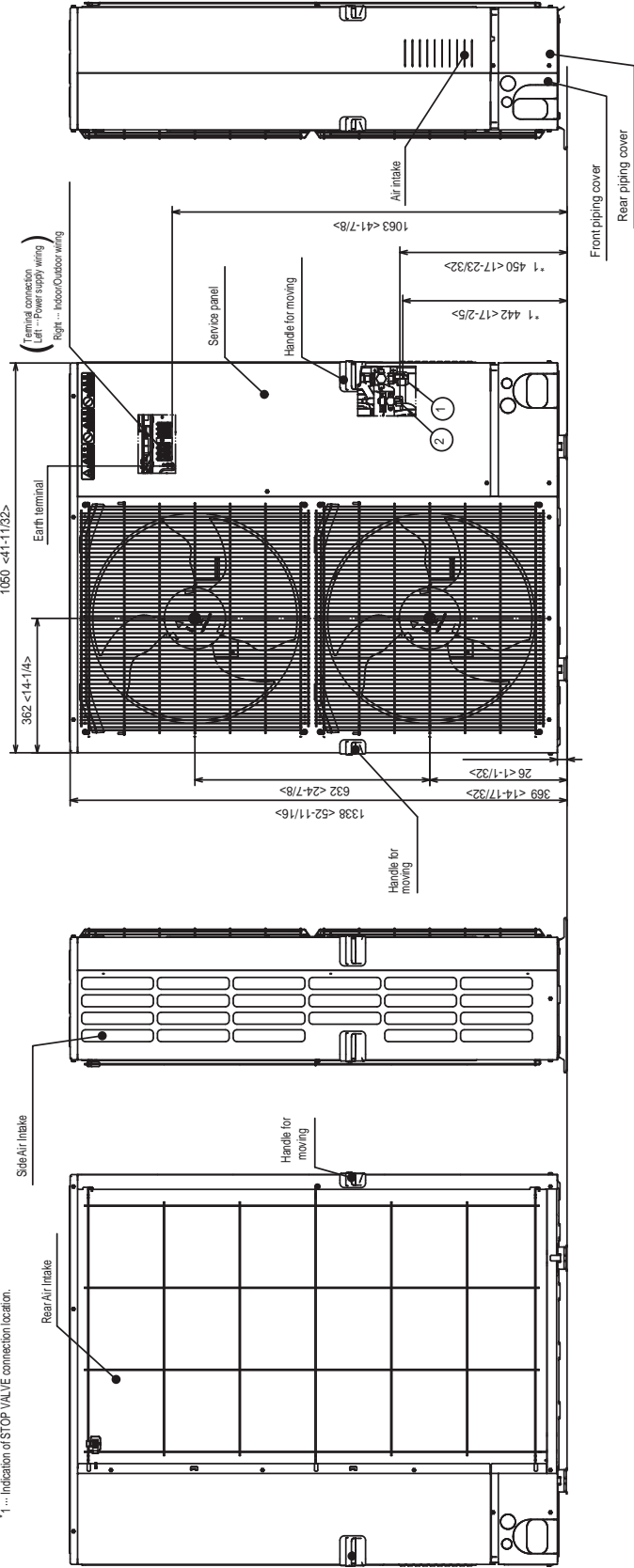
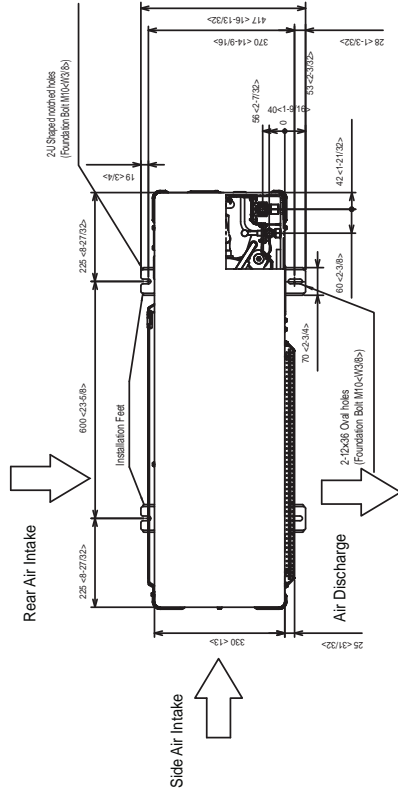

Example of Notes

① ... Refrigerant GAS pipe connection (FLARE) ø15.88(3/8F)

② ... Refrigerant LIQUID pipe connection (FLARE) øø.52(3/8F)

* ... Indication of STOP VALVE connection location.

