

SLZ-KF12NA & SUZ-KA12NAHZ

12,000 Btu/h Ceiling-Cassette Heat Pump

Job Name:	Location:	Date:
Purchaser:	Submitted by:	
Submitted to:	Reference	Approval
System Designation:	Schedule Number #:	
Engineer:		

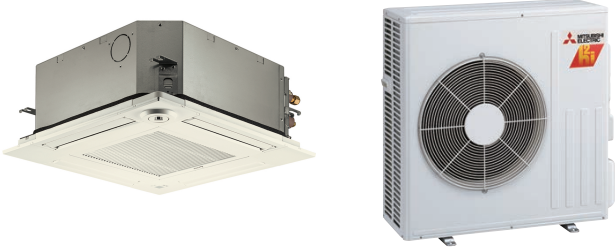

Energy Efficiency	SEER	20.3
	EER	12.7
	HSPF	10.0

Accessories:

- Grille (SLP-18FAEU - Ordered separate) (w/3D i-see sensor)
- Windscreens (ME-FR-24)
- Wired Remote Sensor (PAC-SE41TS-E)
- Outside Air Sensor for MHK1 (MOS1)
- Wire for Remote on/off with CN32 connector (PAC-715AD)
- Connector and wire for Operation status/error using CN51 (PAC-725AD)
- Connector of CN32 (remote on/off) (PAC-SE55RA-E)
- Connector cable for remote display (PAC-SA88HA-EP)

Optional Controls:

- Wired Remote Controller (PAR-40MAA)
- Simple MA Remote Controller (PAC-YT53CRAU-J)
- Thermostat Interface (PAC-US444CN-1)
- System Control Interface (MAC-334IF-E)
- Wireless Remote (PAR-SL100A-E)(Requires PAR-SF9FA-E)
- Backlit, Wall-mounted, Wireless Controller (MHK1)
- Portable Central Controller (MCCH1)

Indoor unit	MCA (*)	A	0.3
	Fan Motor	F.L.A	0.24
	Fan Motor Output	W	50
	Air flow (Lo-Mid-Hi)	DRY(CFM)	230-280-335
		WET(CFM)	207-252-302
	External Static Pressure	in WG	0
	Sound Pressure Level (Lo-Mid-Hi)	dB (A)	25-30-34
	External Finish Color		Munsell 1.0Y 9.2/0.2
	Dimensions	W: in	22-7/16
		D: in	22-7/16
		H: in	8-3/16
	Weight Unit	lbs	30.6
	Field Drainpipe O.D.	in	O.D. 1-1/4
	Refrigerant pipe Gas	in	3/8
	Refrigerant pipe Liquid	in	1/4
Moisture Removal	Pints/h	3.1	
Sensible Heat Factor		0.71	

NOTES : *1.Rating conditions (cooling)-Indoor : D.B. 26.7°C(80°F), W.B. 19.4°C(67°F) Outdoor : D.B. 35°C(95°F), W.B. 23.9°C(75°F)
(heating)-Indoor : D.B. 21.1°C(70°F), W.B. 15.6°C(60°F) Outdoor : D.B. 8.3°C(47°F), W.B. 6.1°C(43°F)
*2.Rating conditions(heating)-Indoor : D.B. 21.1°C(70°F), W.B. 15.6°C(60°F) Outdoor : D.B. -8.3°C(17°F), W.B. -9.4°C(15°F)

Operating range		Indoor intake air temperature		Outdoor intake air temperature	
Cooling	Maximum	D.B. 35°C(95°F)	W.B. 21.7°C(71°F)	D.B. 46°C(115°F)	
	Minimum	D.B. 19.4°C(67°F)	W.B. 13.9°C(57°F)	D.B. -10°C(14°F)	
Heating	Maximum	D.B. 26.7°C(80°F)	W.B. 19.4°C(67°F)	D.B. 24°C(75°F), W.B. 18°C(65°F)	
	Minimum	D.B. 21.1°C(70°F)	W.B. 15.6°C(60°F)	D.B. -25°C(-13°F), W.B. -26°C(-14°F)	

*All electrical work shall comply with National (CEC), local codes and regulations.

Should this document be altered or changed without MESCA's permission, it becomes null and void. MESCA assumes no responsibility for any consequences in such cases.

Note: Mitsubishi Electric (MESCA) supports the use of only MESCA supplied and approved accessories for proper functioning of the unit(s). Use of non-MESCA supported accessories will affect warranty coverage.

SLZ-KF12NA & SUZ-KA12NAHZ

Outdoor unit	MCA (*)	A	14	
	MOCP (*) (Breaker)	A	24 (15)	
	Fan Motor	F.L.A.	0.67	
	Compressor	Model(Type)	DC INVERTER-driven Twin Rotary	
		R.L.A.	10	
		L.R.A.	12.5	
	Air flow (Cooling/Heating)	CFM	(1,691/1,691)	
	Refrigerant Control	Linear Expansion Valve		
	Defrost Method	Reverse Cycle		
	SPL (Cooling)	dB (A)	54	
	SPL (Heating)	dB (A)	55	
	External Finish Color	Munsell No.3Y 7.8/1.1		
	Dimension	W: in	33-1/16	
		D: in	13	
H: in		34-5/8		
Weight	lbs	129		
Remote Controller	Type	Wired Remote Controller		
Refrigerant	Type	R410A		
	Charge	lbs, oz	3,9	
	Oil	Type(Fl.oz.)	FV50S(22.0)	
Refrigerant Pipe	Gas side O.D.	in	3/8	
	Liquid side O.D.	in	1/4	
	Height Difference (Max)	ft	40	
	Length (Max.)	ft	65	
Connection Method	Indoor/Outdoor	Flared/Flared		
Operation Guarantee	Cooling	°F	14 - 115	
	Heating	°F	-13 - 75	

Power supply	Voltage, Phase, Cycle	1-phase, 60Hz, 208/230V
Voltage	Indoor - Outdoor S1-S2	AC 208/230V
	Indoor - Outdoor S2-S3	DC12-24V
	Indoor - Remote controller	DC12V

		MAX (Btu)	MAX RATED INPUT (W)	RATED (Btu)	RATED TOTAL INPUT (W)	COP
Heating	47°F	15,370	1,332	14,628	1,199	3.38
	17°F	11,673	1,053	9,039	948	3.25
	5°F	11,673	819	5,934	737	2.36
	-4°F	8,346	626	3,550	563	1.85
	-13°F	5,019	416	880	374	0.69
Cooling	80°F	13,344	828	13,344	828	4.72

* COP at MAX capacity

*All electrical work shall comply with National (CEC), local codes and regulations.

Should this document be altered or changed without MESCA's permission, it becomes null and void. MESCA assumes no responsibility for any consequences in such cases.

Note: Mitsubishi Electric (MESCA) supports the use of only MESCA supplied and approved accessories for proper functioning of the unit(s). Use of non-MESCA supported accessories will affect warranty coverage.

SLZ-KF12NA & SUZ-KA012AHZ

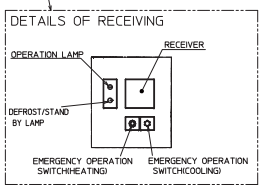
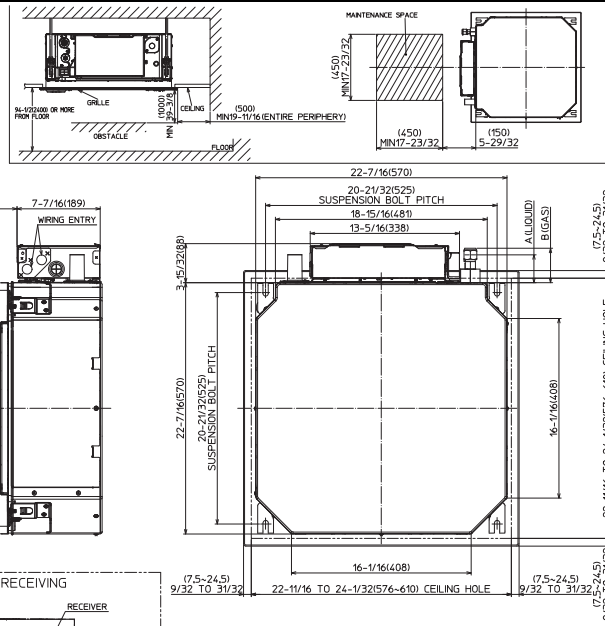
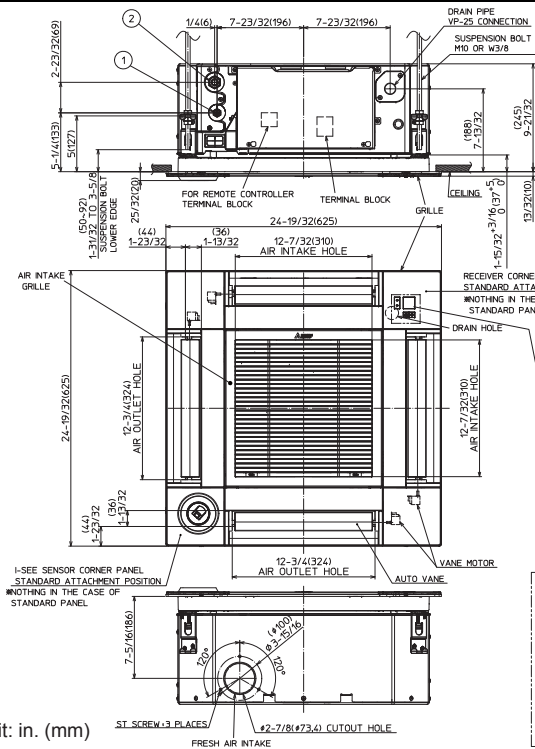

MODELS	Ø REFRIGERANT PIPE (LIQUID)	Ø REFRIGERANT PIPE (GAS)	A	B
SLZ-KF09/12NA,TH	#1/4(φ6.35mm) FLARED CONNECTION 1/4F	#3/8(φ9.52mm) FLARED CONNECTION 3/8F	(63mm) 2-15/32	(72mm) 2-27/32
SLZ-KF15/18NA,TH	#1/4(φ6.35mm) FLARED CONNECTION 1/4F	1/2(φ12.7mm) FLARED CONNECTION 1/2F	(63mm) 2-15/32	(78mm) 3-1/16

Unit: in. (mm)

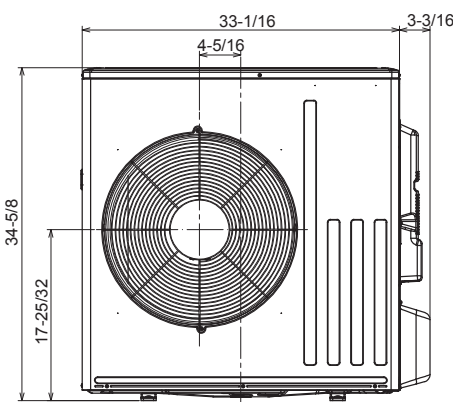
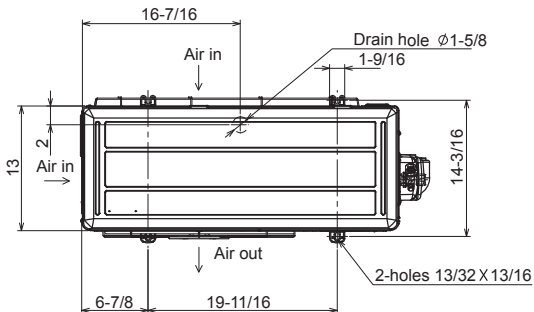

REQUIRED SPACE

*1 20 in. (500 mm) or more when front and sides of the unit are clear

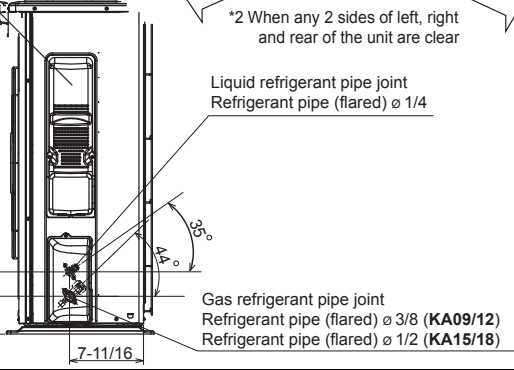
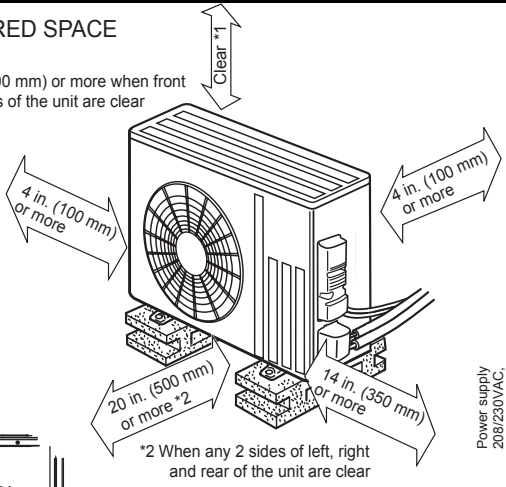

Unit: inch

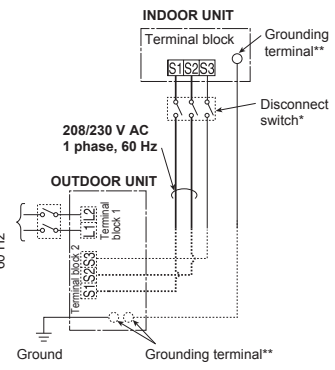

Remark:
* A disconnect switch is required. Check the local code.
** Use a ring tongue terminal in order to connect a ground wire to terminal.



*All electrical work shall comply with National (CEC), local codes and regulations.

Should this document be altered or changed without MESCA's permission, it becomes null and void. MESCA assumes no responsibility for any consequences in such cases.

Note: Mitsubishi Electric (MESCA) supports the use of only MESCA supplied and approved accessories for proper functioning of the unit(s). Use of non-MESCA supported accessories will affect warranty coverage.