

TECHNICAL & SERVICE MANUAL

[Model Name]
<Branch box>

PAC-MKA33BC

PAC-MKA53BC

[Service Ref.]

PAC-MKA33BC

PAC-MKA53BC

Note:

- This service manual describes technical data of branch box. As for indoor units and outdoor unit, refer to its service manual.

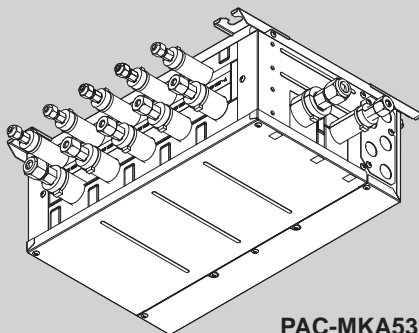

PAC-MKA53BC

BRANCH BOX

CONTENTS

1. SAFETY PRECAUTION.....	2
2. OVERVIEW OF UNIT	5
3. SPECIFICATIONS	8
4. OUTLINES AND DIMENSIONS.....	9
5. WIRING DIAGRAM.....	10
6. NECESSARY CONDITIONS FOR SYSTEM CONSTRUCTION	11
7. TROUBLESHOOTING.....	15
8. DISASSEMBLY PROCEDURE.....	24

PARTS CATALOG (OCB801)

1-1. CAUTIONS RELATED TO NEW REFRIGERANT

Cautions for units utilizing refrigerant R410A

Preparation before the repair service

- Prepare the proper tools.
- Prepare the proper protectors.
- Provide adequate ventilation.
- After stopping the operation of the air conditioner, turn off the power-supply breaker.
- Discharge the condenser before the work involving the electric parts.

Use new refrigerant pipes.

Avoid using thin pipes.

Make sure that the inside and outside of refrigerant piping is clean and it has no contaminants such as sulfur, oxides, dirt, shaving particles, etc., which are hazard to refrigerant cycle. In addition, use pipes with specified thickness.

Contamination inside refrigerant piping can cause deterioration of refrigerant oil, etc.

Store the piping indoors, and keep both ends of the piping sealed until just before brazing. (Leave elbow joints, etc. in their packaging.)

If dirt, dust or moisture enters into refrigerant cycle, that can cause deterioration of refrigerant oil or malfunction of compressor.

The refrigerant oil applied to flare and flange connections must be ester oil, ether oil or alkylbenzene oil in a small amount.

If large amount of mineral oil enters, that can cause deterioration of refrigerant oil, etc.

Charge refrigerant from liquid phase of gas cylinder.

If the refrigerant is charged from gas phase, composition change may occur in refrigerant and the efficiency will be lowered.

Do not use refrigerant other than R410A.

If other refrigerant (R22, etc.) is used, chlorine in refrigerant can cause deterioration of refrigerant oil, etc.

Precautions during the repair service

- Do not perform the work involving the electric parts with wet hands.
- Do not pour water into the electric parts.
- Do not touch the refrigerant.
- Do not touch the hot or cold areas in the refrigerating cycle.
- When the repair or the inspection of the circuit needs to be done without turning off the power, exercise great caution not to touch the live parts.

Use a vacuum pump with a reverse flow check valve.

Vacuum pump oil may flow back into refrigerant cycle and that can cause deterioration of refrigerant oil, etc.

Use the following tools specifically designed for use with R410A refrigerant.

The following tools are necessary to use R410A refrigerant.

Tools for R410A	
Gauge manifold	Flare tool
Charge hose	Size adjustment gauge
Gas leak detector	Vacuum pump adaptor
Torque wrench	Electronic refrigerant charging scale

Handle tools with care.

If dirt, dust or moisture enters into refrigerant cycle, that can cause deterioration of refrigerant oil or malfunction of compressor.

Do not use a charging cylinder.

If a charging cylinder is used, the composition of refrigerant will change and the efficiency will be lowered.

Ventilate the room if refrigerant leaks during operation. If refrigerant comes into contact with a flame, poisonous gases will be released.

Use the specified refrigerant only.

Never use any refrigerant other than that specified. Doing so may cause a burst, an explosion, or fire when the unit is being used, serviced, or disposed of. Correct refrigerant is specified in the manuals and on the spec labels provided with our products. We will not be held responsible for mechanical failure, system malfunction, unit breakdown or accidents caused by failure to follow the instructions.

[1] Cautions for service

- (1) Perform service after recovering the refrigerant left in unit completely.
- (2) Do not release refrigerant in the air.
- (3) After completing service, charge the cycle with specified amount of refrigerant.
- (4) If moisture or foreign matter might have entered the refrigerant piping during service, ensure to remove them.

[2] Additional refrigerant charge

When charging directly from cylinder

- (1) Check that cylinder for R410A on the market is a syphon type.
- (2) Charging should be performed with the cylinder of syphon stood vertically. (Refrigerant is charged from liquid phase.)

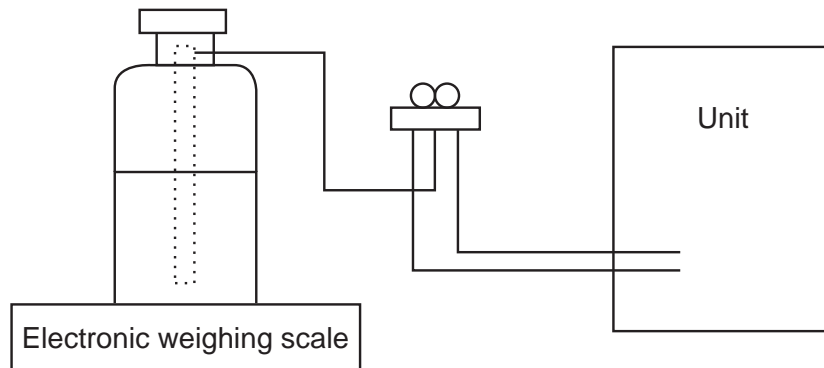

[3] Service tools

(1) Use the below service tools as exclusive tools for R410A refrigerant.

No.	Tool name	Specifications
①	Gauge manifold	· Only for R410A
		· Use the existing fitting specifications. (UNF1/2)
		· Use high-tension side pressure of 5.3MPa·G or over.
②	Charge hose	· Only for R410A
		· Use pressure performance of 5.09MPa·G or over.
③	Electronic weighing scale	—
④	Gas leak detector	· Use the detector for R134a, R407C or R410A.
⑤	Adaptor for reverse flow check	· Attach on vacuum pump.
⑥	Refrigerant charge base	—
⑦	Refrigerant cylinder	· Only for R410A · Top of cylinder (Pink)
		· Cylinder with syphon
	Refrigerant recovery equipment	—

(2) Cautions for refrigerant piping work

New refrigerant R410A is adopted for replacement inverter series. Although the refrigerant piping work for R410A is same as for R22, exclusive tools are necessary so as not to mix with different kind of refrigerant. Furthermore as the working pressure of R410A is 1.6 times higher than that of R22, their sizes of flared sections and flare nuts are different.

① Thickness of pipes

Because the working pressure of R410A is higher compared to R22, be sure to use refrigerant piping with thickness shown below. (Never use pipes of 0.7 mm or below.)

Diagram below: Piping diameter and thickness

Nominal dimensions (in)	Outside diameter (mm)	Thickness (mm)	
		R410A	R22
1/4	ø6.35	0.8	0.8
3/8	ø9.52	0.8	0.8
1/2	ø12.70	0.8	0.8
5/8	ø15.88	1.0	1.0
3/4	ø19.05	—	1.0

② Dimensions of flare cutting and flare nut

The component molecules in HFC refrigerant are smaller compared to conventional refrigerants. In addition to that, R410A is a refrigerant, which has higher risk of leakage because its working pressure higher than that of other refrigerants. Therefore, to enhance airtightness and strength, flare cutting dimension of copper pipe for R410A has been specified separately from the dimensions for other refrigerants as shown below. The dimension B of flare nut for R410A also has partly been changed to increase strength as shown below. Set copper pipe correctly referring to copper pipe flaring dimensions for R410A below. For 1/2" and 5/8" inch pipes, the dimension B changes.

Use torque wrench corresponding to each dimension.

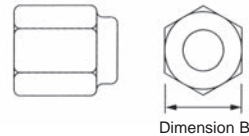
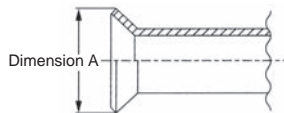

Flare cutting dimensions

Nominal dimensions (in)	Outside diameter (mm)	Dimension A ($^{+0}_{-0.4}$)(mm)	
		R410A	R22
1/4	ø6.35	9.1	9.0
3/8	ø9.52	13.2	13.0
1/2	ø12.70	16.6	16.2
5/8	ø15.88	19.7	19.4
3/4	ø19.05	—	23.3

Flare nut dimensions

Nominal dimensions (in)	Outside diameter (mm)	Dimension B (mm)	
		R410A	R22
1/4	ø6.35	17.0	17.0
3/8	ø9.52	22.0	22.0
1/2	ø12.70	26.0	24.0
5/8	ø15.88	29.0	27.0
3/4	ø19.05	—	36.0

③ Tools for R410A (The following table shows whether conventional tools can be used or not.)

Tools and materials	Use	R410A tools	Can R22 tools be used?	Can R407C tools be used?
Gauge manifold	Air purge, refrigerant charge and operation check	Tool exclusive for R410A	×	×
Charge hose		Tool exclusive for R410A	×	×
Gas leak detector	Gas leak check	Tool for HFC refrigerant	×	○
Refrigerant recovery equipment	Refrigerant recovery	Tool exclusive for R410A	×	×
Refrigerant cylinder	Refrigerant charge	Tool exclusive for R410A	×	×
Applied oil	Apply to flared section	Ester oil and alkylbenzene oil (minimum amount)	×	Ester oil: ○ Alkylbenzene oil: minimum amount
Safety charger	Prevent compressor malfunction when charging refrigerant by spraying liquid refrigerant	Tool exclusive for R410A	×	×
Charge valve	Prevent gas from blowing out when detaching charge hose	Tool exclusive for R410A	×	×
Vacuum pump	Vacuum drying and air purge	Tools for other refrigerants can be used if equipped with adapter for reverse flow check	△ (Usable if equipped with adapter for reverse flow)	△ (Usable if equipped with adapter for reverse flow)
Flare tool	Flaring work of piping	Tools for other refrigerants can be used by adjusting flaring dimension	△ (Usable by adjusting flaring dimension)	△ (Usable by adjusting flaring dimension)
Bender	Bend the pipes	Tools for other refrigerants can be used	○	○
Pipe cutter	Cut the pipes	Tools for other refrigerants can be used	○	○
Welder and nitrogen gas cylinder	Weld the pipes	Tools for other refrigerants can be used	○	○
Refrigerant charging scale	Refrigerant charge	Tools for other refrigerants can be used	○	○
Vacuum gauge or thermistor vacuum gauge and vacuum valve	Check the degree of vacuum. (Vacuum valve prevents back flow of oil and refrigerant to thermistor vacuum gauge)	Tools for other refrigerants can be used	○	○
Charging cylinder	Refrigerant charge	Tool exclusive for R410A	×	—

× : Prepare a new tool. (Use the new tool as the tool exclusive for R410A.)

△ : Tools for other refrigerants can be used under certain conditions.

○ : Tools for other refrigerants can be used.

2-1. SYSTEM OUTLINE

The additional connection of the branch box together with employment of the compact trunk-looking outdoor unit can successfully realize a long distance piping for big houses. Equipped with a microprocessor, the branch box can translate the transmission signal of indoor units to achieve the optimum control.

2-1-1. System example

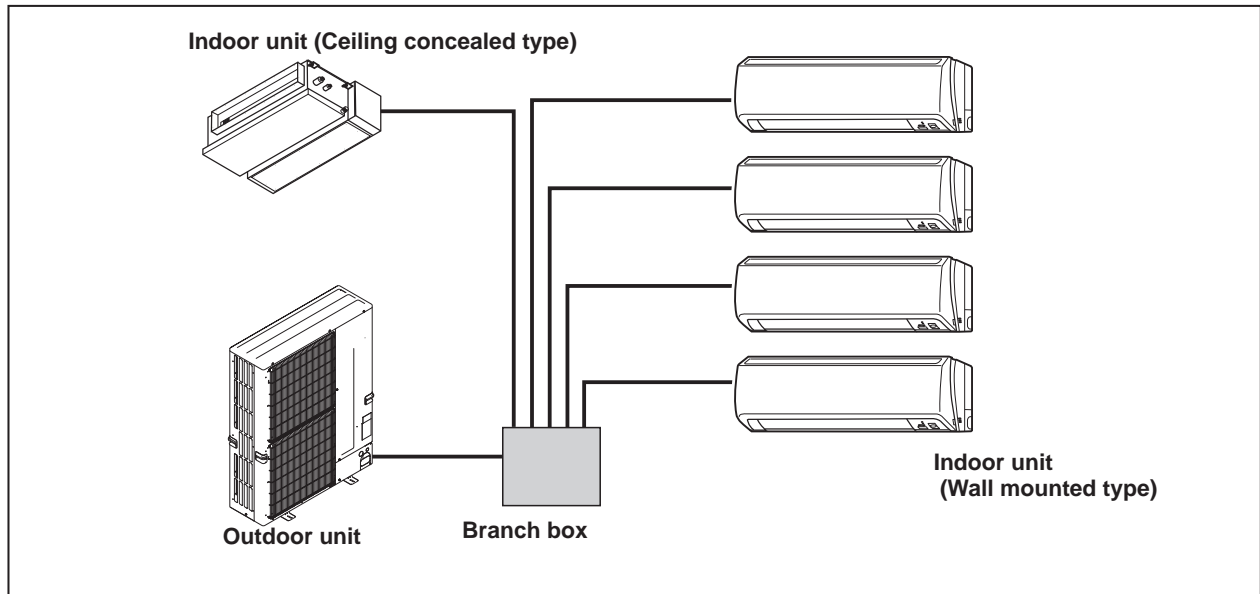

2-1-2. Method for identifying

■ Branch box

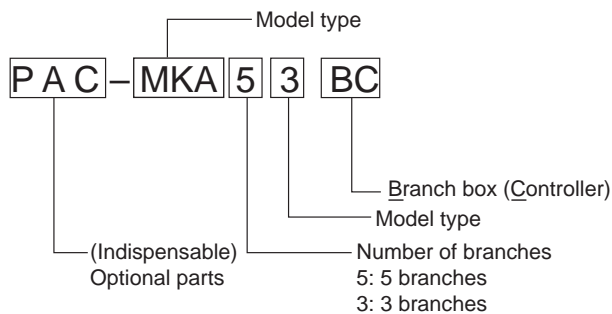

2-3. SIMPLIFIED PIPING SYSTEM

The piping connection size differs according to the type and capacity of outdoor/indoor units.

Match the piping connection size of branch box with outdoor/indoor unit.

If the piping connection size of branch box does not match the piping connection size of outdoor/indoor unit, use optional different-diameter (deformed) joints to the branch box side.

(Connect deformed joint directly to the branch box side.)

- In the case of using 1-branch box
Flare connection employed

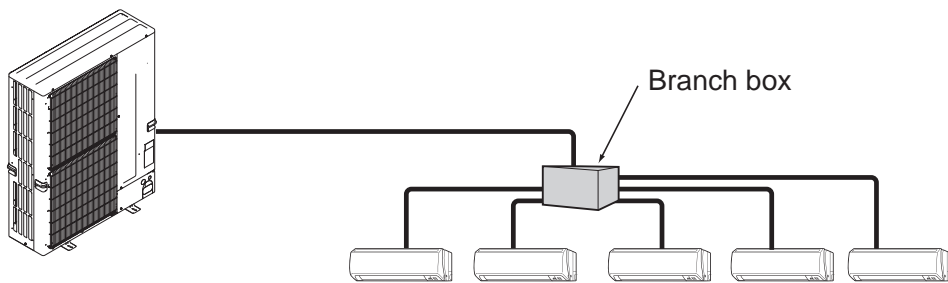

- In the case of using 2-branch boxes

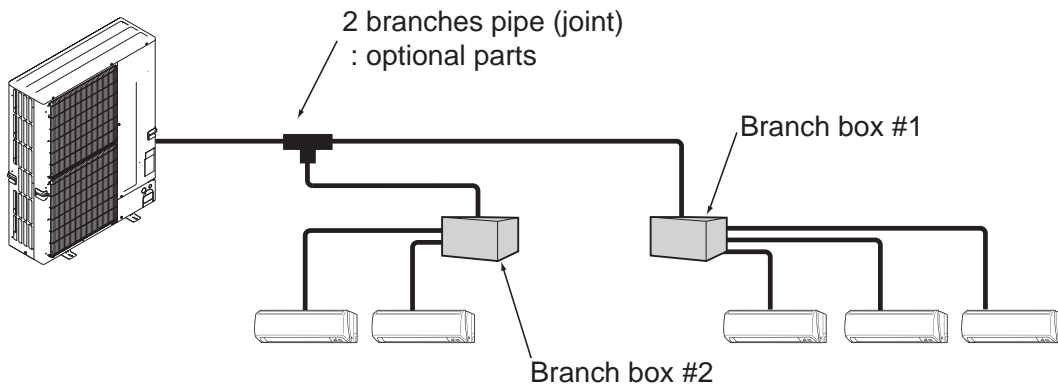

- Installation procedure (2 branches pipe (joint))
Refer to the installation manuals of MSDD-50AR-E and MSDD-50BR-E.

3

SPECIFICATIONS

Model name			PAC-MKA53BC	PAC-MKA33BC	
Connectable number of indoor units			Maximum 5	Maximum 3	
Power supply			Single phase, 208/230 V, 60 Hz		
Input		kW	0.003		
Running current		A	0.15		
External finish			Galvanized sheets		
Dimensions	Width	in (mm)	17-23/32 (450)		
	Depth	in (mm)	11-1/32 (280)		
	Height	in (mm)	6-11/16 (170)		
Weight		lb (kg)	16 (7.4)	15 (6.7)	
Piping connection (Flare)	Branch (indoor side)*	Liquid	in (mm)	1/4 (ø6.35) × 5 {A,B,C,D,E}	1/4 (ø6.35) × 3 {A,B,C}
		Gas	in (mm)	3/8 (ø9.52) × 4 {A,B,C,D}, 1/2 (ø12.7) × 1 {E}	3/8 (ø9.52) × 3 {A,B,C}
	Main (outdoor side)	Liquid	in (mm)	3/8 (ø9.52)	
		Gas	in (mm)	5/8 (ø15.88)	

* The piping connection size differs according to the type and capacity of indoor units. Match the piping connection size for indoor and branch box. If the piping connection size of branch box does not match the piping connection size of indoor units, use optional different-diameter (deformed) joints to the branch box side. (Connect deformed joint directly to the branch box side.)

4

OUTLINES AND DIMENSIONS

PAC-MKA33BC

Unit: mm(inch)

SUSPENSION BOLT: W3/8(M10)
REFRIGERANT PIPE FLARED CONNECTION Unit: inch

	A	B	C		TO OUTDOOR UNIT
LIQUID PIPE	1/4F	1/4F	1/4F		3/8F
GAS PIPE	3/8F	3/8F	3/8F		5/8F

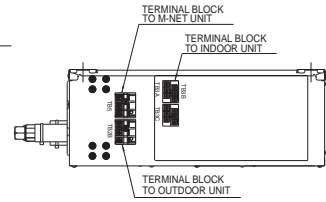
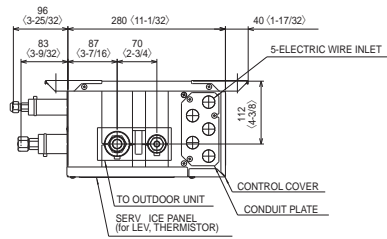
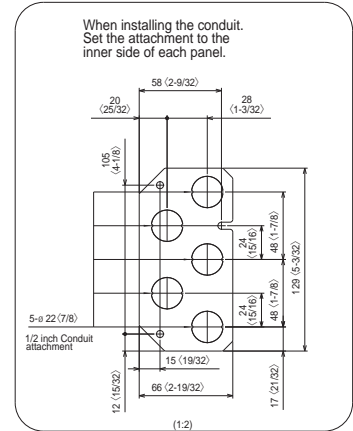
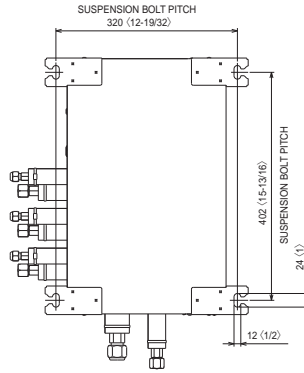
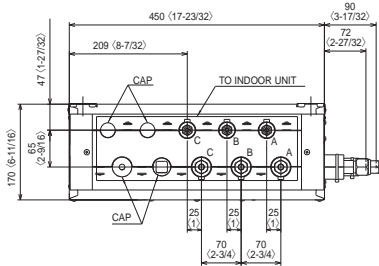

PAC-MKA53BC

SUSPENSION BOLT: W3/8(M10)
REFRIGERANT PIPE FLARED CONNECTION Unit: inch

	A	B	C	D	E	TO OUTDOOR UNIT
LIQUID PIPE	1/4F	1/4F	1/4F	1/4F	1/4F	3/8F
GAS PIPE	3/8F	3/8F	3/8F	3/8F	1/2F	5/8F

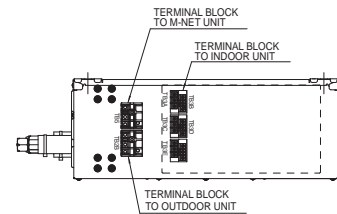
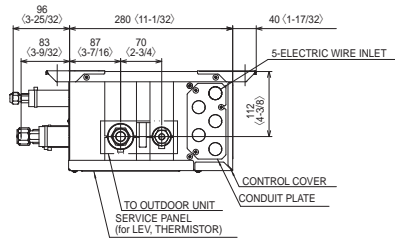
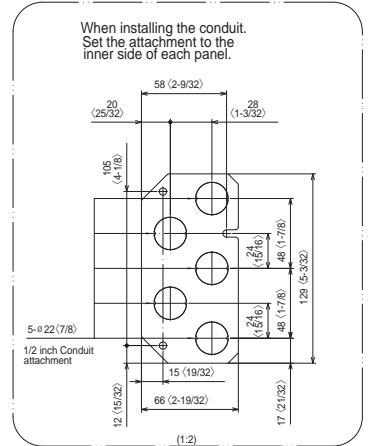
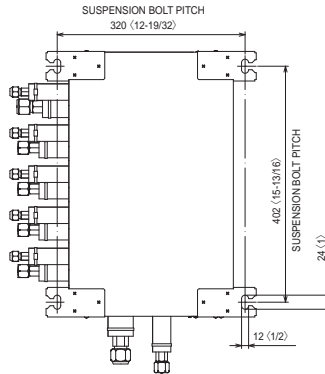
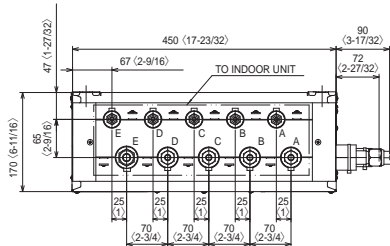

[LEGEND]

SYMBOL	NAME
B.C.	Branch box controller board
F1	Fuse <UL 6.3A 250V AC>
F2-F4	Fuse <UL 10A 250V AC> *1
SW1	Switch for indoor unit connection *2
SW4	Switch for function selection
SW5	Switch for function selection
CNM	Connector <Connection for service>
LED1,2	Light emitting diode *3
TB3A-E	Terminal block <To Indoor unit-A-E> *4
SW11	Address Setting 1s digit
SW12	Address Setting 10s digit
LEV-A-E	Linear expansion valve *4
TH-A-E	Thermistor <Gas pipe> *4
TB2B	Terminal block <To Power Supply>
TB5	Terminal block <To Transmission>

*1 F4 for PAC-MKA53BC only

*2 SW1 setting

SW1-1	INDOOR UNIT-A	OFF	ON
SW1-2	INDOOR UNIT-B	NOT CONNECT	CONNECT
SW1-3	INDOOR UNIT-C	NOT CONNECT	CONNECT
SW1-4	INDOOR UNIT-D	NOT CONNECT	CONNECT
SW1-5	INDOOR UNIT-E	NOT CONNECT	CONNECT
SW1-6	NO USE		

} PAC-MKA 53BC only

After each indoor unit is connected to the outdoor unit, turn on the switch corresponding to each indoor unit. For example, when the indoor units are connected to INDOOR UNIT-A and C, turn SW1-1 and SW1-3 to on.

*3 LED on Branch box controller board for service
• start-up

Mark	Meaning	Function
LED 1	Main power supply	Main power supply (208/230V)
LED 2		Power on → Lamps are lit

• normal operating

Mark	Meaning	Function
LED 1	Main power supply	Lamp is lit
LED 2	Total number of indoor units	Blink depend on the total number <example> The total number is 2 ① Blink 2 times. ② Turn off for 3 sec. ③ Repeat ① to ②.

*4 D and E for PAC-MKA53BC only

<Combination of indoor units>

Enter the location of combined indoor units with model name in each blank below because it is necessary for service and maintenance.

Indoor unit-A	Indoor unit-B	Indoor unit-C	Indoor unit-D	Indoor unit-E

<Note>

- When servicing for outdoor unit, always follow the wiring diagram of outdoor unit.
- Caution for electrical work.
 - Use copper supply wires. (Utiliser des fils d'alimentation en cuivre.)
- When work to supply power separately to Branch box and outdoor units are applied, refer to Fig. 1.
- For the connection method, please refer to the Branch box Installation Manual.

<Symbols used in wiring diagram>

- : Terminal block, : Connector
- : Dip switch (■(black square) indicates a switch position)

Address switch settings of SW11 and SW12 (Set them before turning on the power.)
The address of the Branch box is set with the combination of the 10s and 1s digits.
The addresses of the indoor units A to E are assigned by the address switches of each controller board (SW11 and SW12) and the dip switches (SW1-1 to 1-5).
For setting methods, refer to both the Installation Manuals of the outdoor unit and the Branch box.

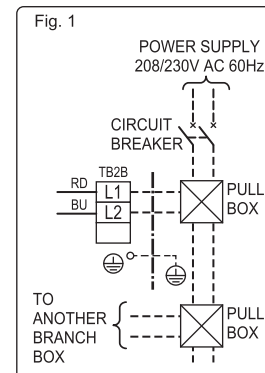
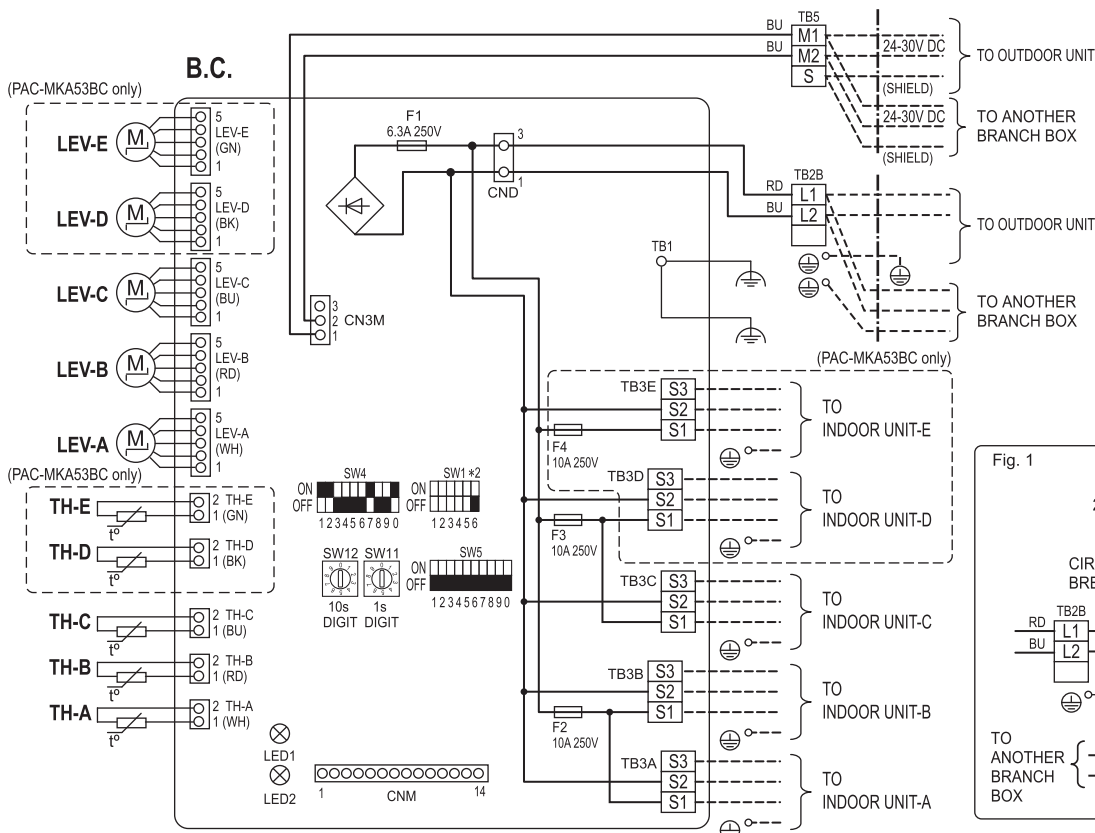

6-1. TRANSMISSION SYSTEM SETUP

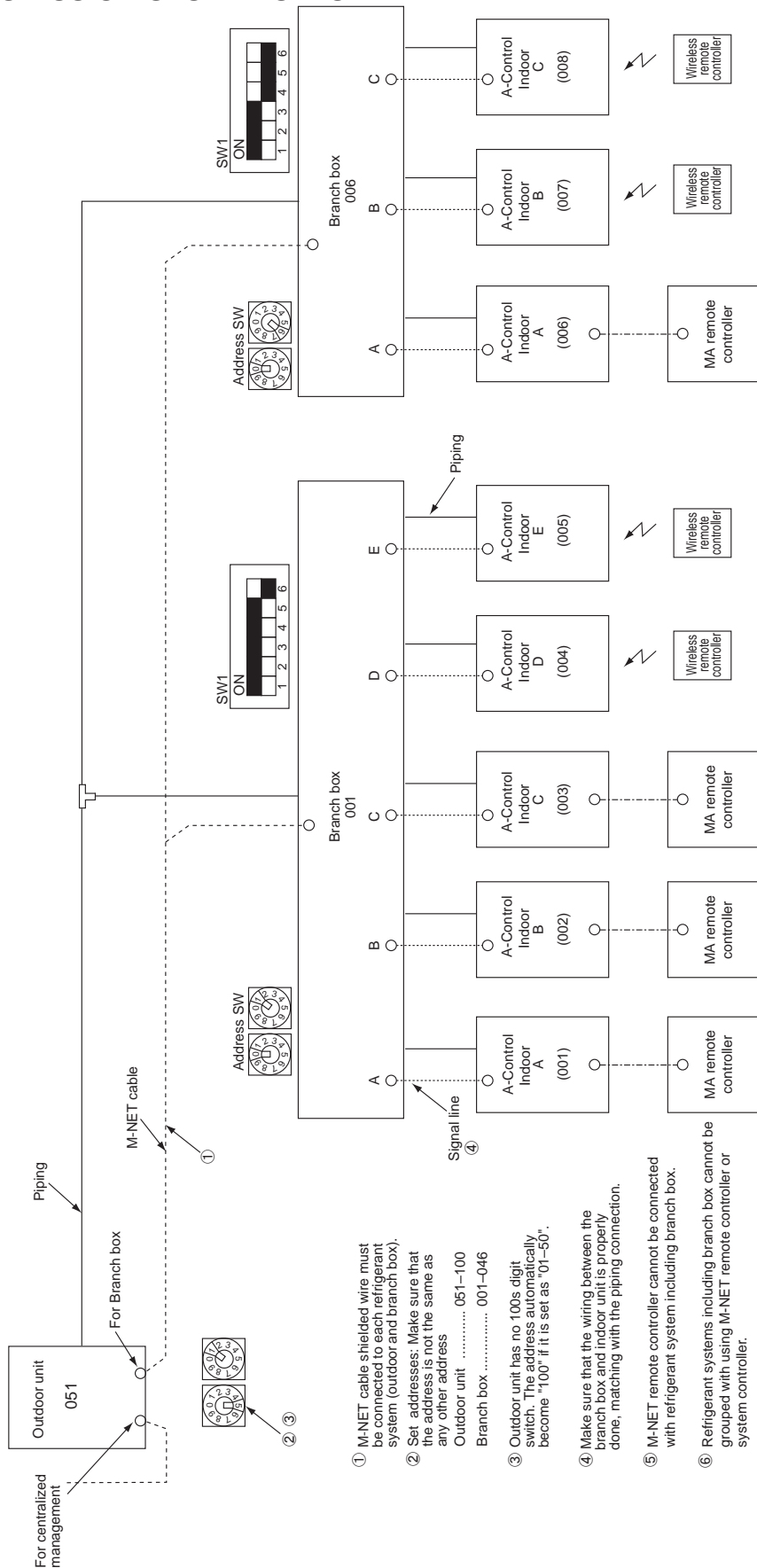

- ① M-NET cable shielded wire must be connected to each refrigerant system (outdoor and branch box).
- ② Set addresses: Make sure that the address is not the same as any other address
Outdoor unit 051-100
Branch box 001-046
- ③ Outdoor unit has no 100s digit switch. The address automatically become "100" if it is set as "01-50".
- ④ Make sure that the wiring between the branch box and indoor unit is properly done, matching with the piping connection.
- ⑤ M-NET remote controller cannot be connected with refrigerant system including branch box.
- ⑥ Refrigerant systems including branch box cannot be grouped with using M-NET remote controller or system controller.

6-2. REFRIGERANT SYSTEM DIAGRAM

■ PAC-MKA53BC

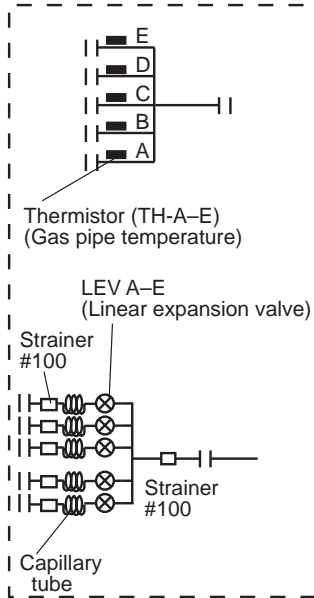

■ PAC-MKA33BC

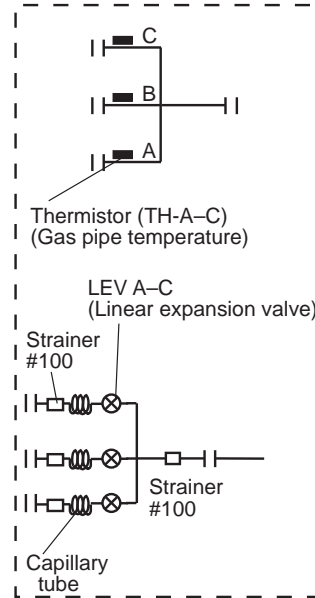

Unit: mm

		Capillary tube behind LEV (in cooling mode)
Branch box	PAC-MKA53BC	$(\varnothing 0.157 \times \varnothing 0.117 \times L(5-1/8)) \times 5$ $(\varnothing 4 \times \varnothing 3.0 \times L130) \times 5$
	PAC-MKA33BC	$(\varnothing 0.157 \times \varnothing 0.117 \times L(5-1/8)) \times 3$ $(\varnothing 4 \times \varnothing 3.0 \times L130) \times 3$

6-3. TYPICAL CONTROL SYSTEM

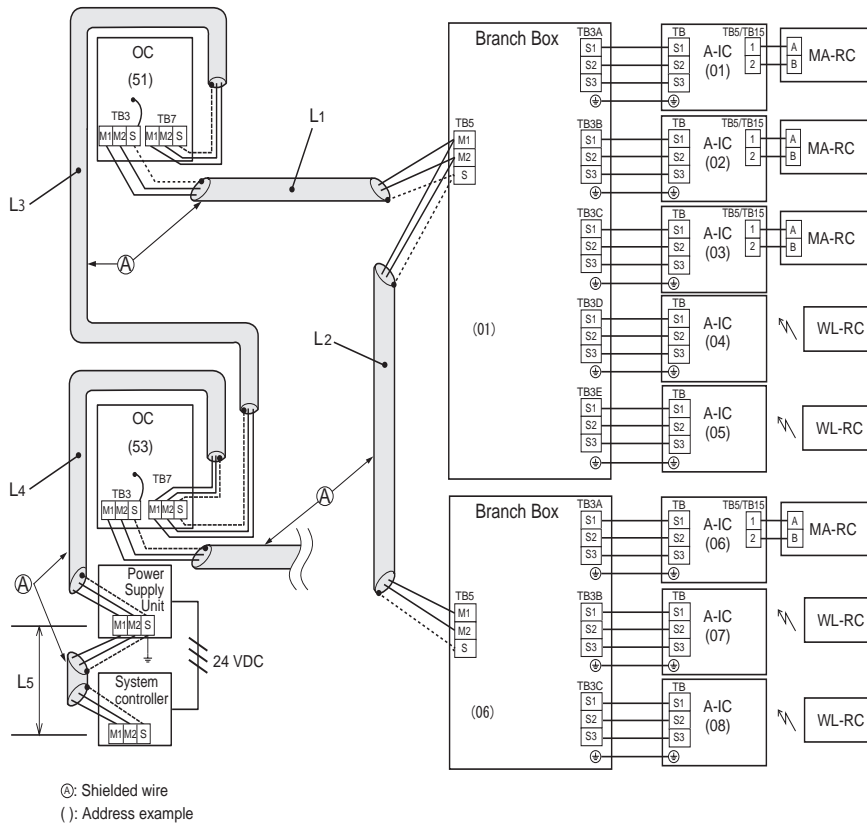

Note: M-NET remote controller cannot be connected with a refrigerant system which includes branch box.

(1) Difference between display and operation

- ① When operating the system using the system controller, details of those operations will not appear on the display of the wireless remote controller.
- ② The set temperature range is different in the wireless remote controller that comes with room air conditioner and the system controller. The room air conditioner has a wider range. If the target temperature is set to below 63°F [17°C] or less, or 86°F [30°C] or more by the wireless remote controller that comes with room air conditioner, the temperature displayed on the system controller may be converted to their maximum/minimum set temperature. For instance, when HEAT operation at 61°F [16°C] is set at the room air conditioner, the system controller may display 63°F [17°C].
- ③ When DRY mode is set with the wireless remote controller, the room air conditioner automatically set the optimum target temperature. The system controller will display the target temperature as a set temperature.
- ④ When DRY mode is set with the system controller, the room air conditioner performs DRY mode control operation according to the temperature set with the system controller.

(2) Timer operation

- ① Timer operation should be set using only 1 controller from the remote controller that comes with the room air conditioner, the system controller or the MA remote controller. If more than 1 controller is used to set the timer at the same time, the timer will not function properly.
- ② When the timer is set with the wireless remote controller; the system controller will not show the timer display.
- ③ The timer set with the system controller will not be cancelled with the wireless remote controller.

(3) Manual operation prohibition

- ① When the manual operation (ON/OFF, set temperature, or operation mode) is prohibited with the system controller, the command to perform the prohibited operation will not be accepted from the wireless remote controller that comes with the room air conditioner. The operation partially enabled by the system controller can be operated with the wireless remote controller. Regardless of whether the operation is disabled or enabled, 3 short beeps will sound when the signal is sent from the wireless remote controller.

(4) Trouble

- ① If the MA remote controller or the system controller shows the abnormal indication, clear it by stopping the operation with one of the following: the MA remote controller, the system controller, or the wireless remote controller. (Abnormal indication of the air conditioner could be recovered automatically, but that of the MA remote controller or the system controller cannot be recovered unless the operation is stopped.)

(5) Group setting

- ① MA group or M-NET group setting cannot be set.

(6) Restricted functions

The following functions of system controller cannot be used.

- DIDO controller (Interlock with the air conditioner)
- Fan control of energy saving control or peak cut control function
- Air conditioning charge [TG-2000A]
- Set temperature range limiting function
- Operation mode changeover limit (season changing) [PAC-SF44SRA]
- Dual set point function
- Setback mode
- Hold function
- MAC-333IF-E

7

TROUBLESHOOTING

7-1. HOW TO CHECK THE PARTS

Parts name	Checkpoint														
Thermistor (TH-A-E) <Gas pipe>	<p>Disconnect the connector then measure the resistance with a multimeter. (At the ambient temperature 50 to 86°F [10 to 30°C])</p> <p>Thermistor R0=15kΩ ± 3% Fixed number of B=3480 ± 2%</p> $R_t = 15 \exp \left\{ 3480 \left(\frac{1}{273+t} - \frac{1}{273} \right) \right\}$ <p>50F° [10°C] 9.7 kΩ 59F° [15°C] 7.9 kΩ 68F° [20°C] 6.4 kΩ 77F° [25°C] 5.3 kΩ 86F° [30°C] 4.4 kΩ</p> <div style="text-align: right;"> <p>< Thermistor for lower temperature ></p> </div>														
Linear expansion valve (LEV-A-E)	<p>Disconnect the connector then measure the resistance with a multimeter. (Winding temperature 68F° [20°C])</p> <table border="1" style="width: 100%; border-collapse: collapse; text-align: center;"> <thead> <tr> <th colspan="4" data-bbox="507 1336 1268 1364">Normal</th> <th data-bbox="1268 1336 1484 1364">Abnormal</th> </tr> </thead> <tbody> <tr> <td data-bbox="507 1364 699 1391">Red - White</td> <td data-bbox="699 1364 890 1391">Red - Orange</td> <td data-bbox="890 1364 1082 1391">Red - Yellow</td> <td data-bbox="1082 1364 1268 1391">Red - Blue</td> <td data-bbox="1268 1364 1484 1391" rowspan="2">Open or short</td> </tr> <tr> <td colspan="4" data-bbox="507 1391 1268 1419">46 ± 4Ω</td> </tr> </tbody> </table>	Normal				Abnormal	Red - White	Red - Orange	Red - Yellow	Red - Blue	Open or short	46 ± 4Ω			
Normal				Abnormal											
Red - White	Red - Orange	Red - Yellow	Red - Blue	Open or short											
46 ± 4Ω															

Linear expansion valve (LEV) in Branch box

(1) Operation summary of the linear expansion valve

- Linear expansion valve opens/closes through stepping motor after receiving the pulse signal from the branch box controller board.
 - Valve position can be changed in proportion to the number of pulse signal.
- <Connection between the branch box controller board and the linear expansion valve>

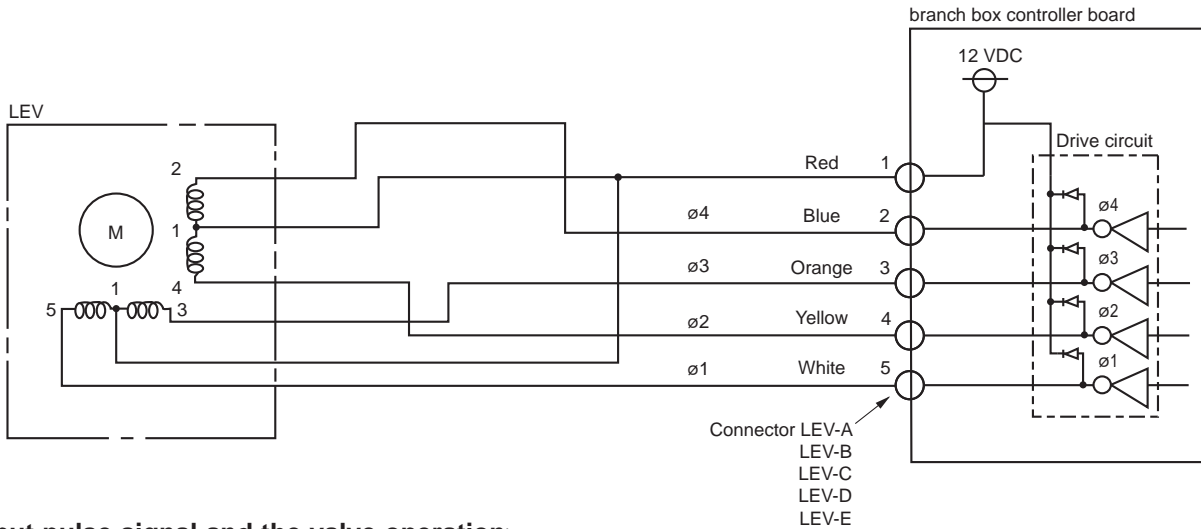

<Output pulse signal and the valve operation>

Output (Phase)	Output							
	1	2	3	4	5	6	7	8
ø1	ON	ON	OFF	OFF	OFF	OFF	OFF	ON
ø2	OFF	ON	ON	ON	OFF	OFF	OFF	OFF
ø3	OFF	OFF	OFF	ON	ON	ON	OFF	OFF
ø4	OFF	OFF	OFF	OFF	OFF	ON	ON	ON

The output pulse shifts in the following order.

Opening a valve: 8 → 7 → 6 → 5 → 4 → 3 → 2 → 1 → 8

Closing a valve: 1 → 2 → 3 → 4 → 5 → 6 → 7 → 8 → 1

- When linear expansion valve operation stops, all output phases become OFF.

(2) Linear expansion valve operation

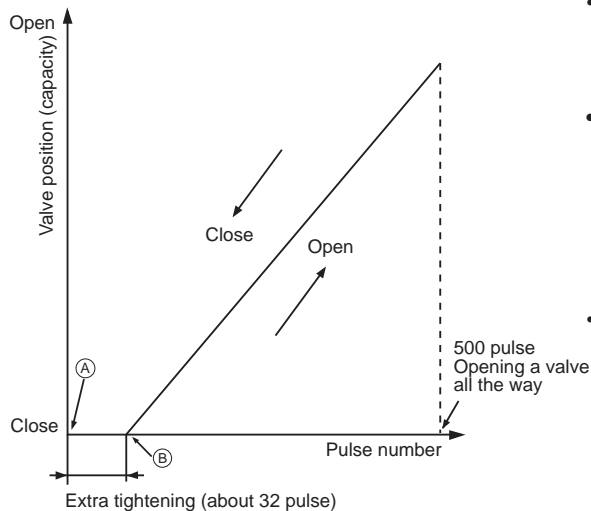

- When the power is turned on, 700 pulse closing valve signal will be sent till it goes to **A** point in order to define the valve position. (The pulse signal is being sent for about 20 seconds.)
- When the valve moves smoothly, there is no sound or vibration occurring from the linear expansion valve: however, when the pulse number moves from **B** to **A** or when the valve is locked, sound can be heard. No sound is heard when the pulse number moves from **B** to **A** in case coil is burnt out or motor is locked by open-phase.
- Sound can be detected by placing the ear against the screw driver handle while putting the screw driver to the linear expansion valve.

(3) How to attach and detach the coil of linear expansion valve

<Composition>

Linear expansion valve is separable into the main body and the coil as shown in the diagram below.

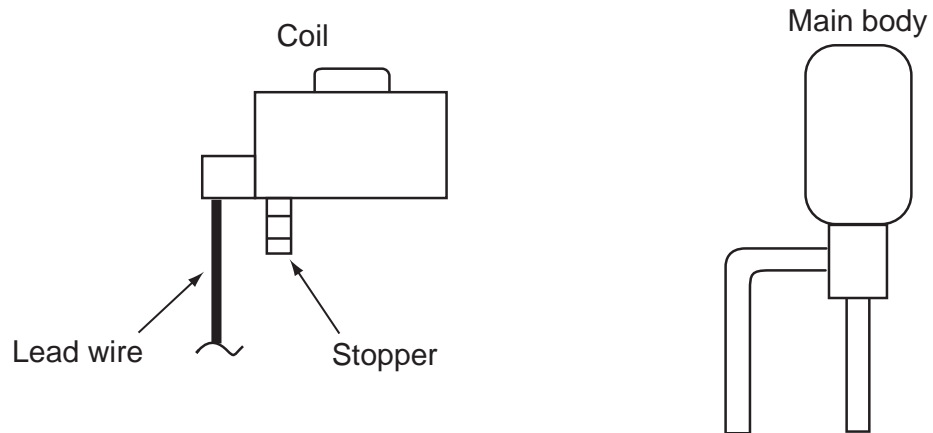

<How to detach the coil>

Hold the lower part of the main body (shown as A) firmly so that the main body does not move and detach the coil by pulling it upward.

Be sure to detach the coil holding main body firmly. Otherwise pipes can bend due to stress.

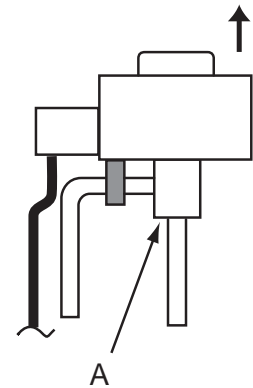

<How to attach the coil>

Hold the lower part of the main body (shown as A) firmly so that the main body does not move and attach the coil by inserting it downward into the main body. Then securely attach the coil stopper to pipe B. (At this time, be careful that stress is not added to lead wire and main body is not wound by lead wire.) If the stopper is not firmly attached to pipe B, coil may be detached from the main body and that can cause defective operation of linear expansion valve.

To prevent piping stress, be sure to attach the coil holding the main body of linear expansion valve firmly. Otherwise pipe may break.

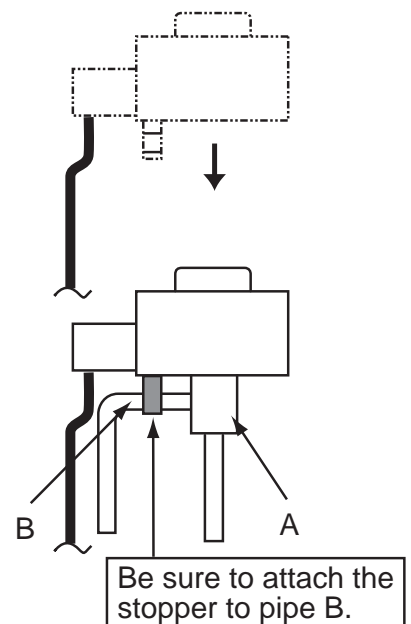

Troubleshooting

Problem	Checkpoint	Corrective measure
Locked expansion valve	If the linear expansion valve becomes locked and the motor is still operating, the motor will emit a clicking noise and will not function. This clicking noise indicates an abnormality.	Replace the linear expansion valve.
Short circuit or broken circuit in expansion valve motor coil	Use an all-purpose electrical meter to measure the resistance between the different coils (red-white, red-orange, red-yellow, red-blue). Normal resistance is within a range of $46 \Omega \pm 4 \Omega/\text{phase}$ (at 20°C).	Replace the linear expansion valve.
Valve does not close completely.	In order to check the linear expansion valve, operate 1 indoor unit in the fan mode and another in the cooling mode. Then, use the outdoor multi controller board to operate the monitor and check the pipe temperature of the indoor unit. The linear expansion valve should be fully closed when the fan is operating. The temperature measured by the temperature sensor will drop if there is any leakage. If the measured temperature is significantly lower than that on the remote controller, this indicates that the valve is not closed. It is not necessary to replace the linear expansion valve if the leak of refrigerant is small and does not cause a malfunction.	Replace the linear expansion valve if there is a major leak of refrigerant.
Incorrect connection or connection failure	① Check improperly connected connector terminals and the wire colors. ② Remove the connector on the controller board side and check electrical conductance.	Continuity check of wrong part





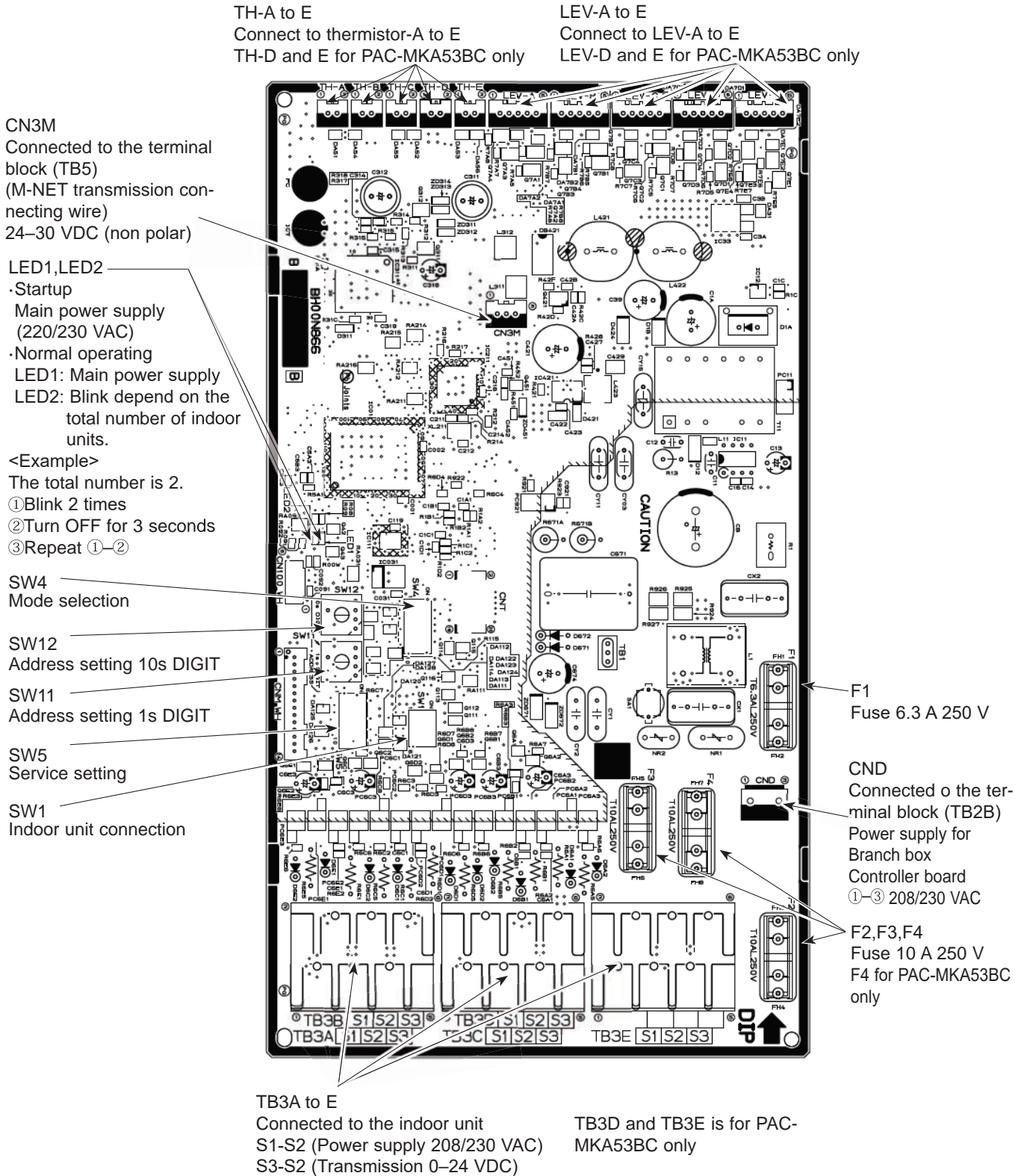



7-2. TEST POINT DIAGRAM

Branch box controller board (B.C.)

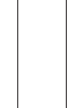

7-3. INTERNAL SWITCH FUNCTION TABLE

The black square (■) indicates a switch position.

Switch	Step	Function	Operation in Each Switch Setting		When to Set	Remarks	Additional Information																			
			ON	OFF																						
SW11 1s digit address setting SW12 10s digit address setting	Rotary switch	How to set addresses Example: if address is "3", remain SW12 (for over 10) at "0", and match SW11 (for 1 to 9) with "3".			Before turning the power ON	<Initial settings> SW12  10s digit SW11  1s digit	—																			
	1-5	<table border="1" data-bbox="335 383 414 553"> <thead> <tr> <th></th> <th>OFF</th> <th>ON</th> </tr> </thead> <tbody> <tr> <td>1 Indoor unit A</td> <td>Not connected</td> <td>Connected</td> </tr> <tr> <td>2 Indoor unit B</td> <td>Not connected</td> <td>Connected</td> </tr> <tr> <td>3 Indoor unit C</td> <td>Not connected</td> <td>Connected</td> </tr> <tr> <td>4*1 Indoor unit D</td> <td>Not connected</td> <td>Connected</td> </tr> <tr> <td>5*1 Indoor unit E</td> <td>Not connected</td> <td>Connected</td> </tr> <tr> <td>6 Not used</td> <td></td> <td></td> </tr> </tbody> </table>		OFF	ON	1 Indoor unit A	Not connected	Connected	2 Indoor unit B	Not connected	Connected	3 Indoor unit C	Not connected	Connected	4*1 Indoor unit D	Not connected	Connected	5*1 Indoor unit E	Not connected	Connected	6 Not used				Before turning the power ON	<Initial settings> ON  OFF 
	OFF	ON																								
1 Indoor unit A	Not connected	Connected																								
2 Indoor unit B	Not connected	Connected																								
3 Indoor unit C	Not connected	Connected																								
4*1 Indoor unit D	Not connected	Connected																								
5*1 Indoor unit E	Not connected	Connected																								
6 Not used																										
SW4 Mode selection	1	—	—	—	—	<Initial settings> ON  OFF 																				
	2	Power-supply voltage setting	230 V	208 V	Set at factory only																					
	3	Change operation if M-NET communication error occurs.	Stop operation	Continued operation																						
	4	Automatic restoration when the power comes back ON.*2	Inactive	Active	Before turning the power ON																					
	5-8	—	—	—	—																					
	9	Detection of branch box pipe thermistors	No detection	Detection	Before turning the power ON																					
	0	—	—	—	—																					
SW5 Service setting	1-3	Change INDOOR UNIT No. for monitoring	Refer to "7-4. BRANCH BOX UNIT OPERATION MONITOR FUNCTION".	Can be activated at any time		<Initial settings> ON  OFF 	—																			

*1 Only for 5-branches model. NOT USED for 3-branches model.

*2 Note that the automatic restoration starts after the unit has stopped once.

7-4. BRANCH BOX UNIT OPERATION MONITOR FUNCTION

[When optional part 'A-Control Service Tool (PAC-SK52ST)' is connected to branch box controller board (CNM)]
 Digital indicator LED1 displays 2 digit number or code to inform operation condition and the meaning of check code by controlling DIP SW2 on 'A-Control Service Tool'.

<Table1> SW5 setting The black square (■) indicates a switch position.

SW5 setting	Detail
	Common
	Indoor-A
	Indoor-B
	Indoor-C
	Indoor-D
	Indoor-E

Operation indicator:

- SW2 - Use to set the displayed item
- SW5 - Use to set the displayed unit







<Table2> Functions

The black square (■) indicates a switch position.

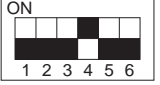
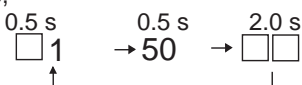
SW2 setting	SW5 setting*1	Display detail	Explanation for display	Unit
	Common	Status of branch box	<p>During startup</p> <p>During error detection Displays a check code, and M-NET address of the unit which the check code was detected. Example: If the check code 2520 is detected in the address3, </p> <p>During no power supply F8</p> <p>Other Displays the number of units in operation. 0 to 5</p>	—
	Individual unit	Status of branch box	<p>During startup</p> <p>During error detection Displays a check code, and M-NET address of the selected unit.</p> <p>During no power supply F8</p> <p>Other Displays an operation mode of the selected unit. 0: Stop C: Cool/ Dry H: Heat d: Defrost</p>	—

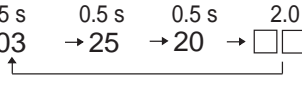
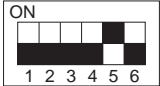



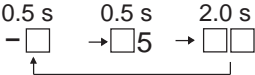

*1 Refer to the <Table 1> for the appropriate setting for the function.

The black square (■) indicates a switch position.

SW2 setting	SW5 setting*1	Display detail	Explanation for display	Unit
	Common	Not used	—	—
	Individual unit	Actual opening pulse of LEV (Direct-operated conversion value) 0 to 500	0 to 500 (When it is 100 pulse or more, it displays a hundredth, tens, and unit digit by turns.) Example: When 150 pulse, <div style="text-align: center;">  </div>	Pulse
	Common	Not used	—	—
	Individual unit	Error history	Displays a check code, and M-NET address of the unit which the check code was detected. Example: If the check code 2520 is detected in the address3, <div style="text-align: center;">  </div>	Code display
	Common	The number of unit(s) operating in Thermo-ON	0 to 5	Number
	Individual unit	Operating status of unit	83: Abnormal 00: Stop 06: Forced stop 0C: Defrost 29: Hot adjust mode 05: Standby mode 2A: Auxiliary heater is ON. 0A: Thermo-ON 01: In operation	Code display
	Common	The number of indoor unit(s) connected to this branch box.	0 to 5	Number
	Individual unit	M-NET address	00 to FF Displays an M-NET address of the selected unit.	Code display
	Common	Not used	—	—
	Individual unit	Capacity setting in Qj	03 to 50	Code display
	Common	Not used	—	—
	Individual unit	Indoor thermistor <pipe temperature/ liquid> (TH2)	-38 to 190 [-39 to 88] (When the temperature is 0°F or less, "-" and temperature are displayed by turns.) Example: When -5°F, <div style="text-align: center;">  </div>	°F

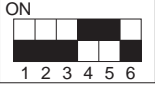
*1 Refer to the <Table 1> for the appropriate setting for the function.

The black square (■) indicates a switch position.

SW2 setting	SW5 setting*1	Display detail	Explanation for display	Unit
	Common	Not used	—	—
	Individual unit	Indoor thermistor <pipe temperature/ 2-phase> (TH5)	-38 to 190 [-39 to 88] (When the temperature is 0°F or less, "-" and temperature are displayed by turns.) Example: When -5°F, <div style="text-align: center;"> 0.5 s 0.5 s 2.0 s -□ →□5 →□□ ↑—————┘ </div>	°F
	Common	Not used	—	—
	Individual unit	Branch box pipe thermistor (TH-A, B, C, D, E)	-43 to 196 [-42 to 91] (When the temperature is 0°F or less, "-" and temperature are displayed by turns.) Example: When -5°F, <div style="text-align: center;"> 0.5 s 0.5 s 2.0 s -□ →□5 →□□ ↑—————┘ </div>	°F
	Common	Not used	—	—
	Individual unit	Indoor thermistor <room temperature> (TH1)	43 to 102 [8 to 39]	°F
	Common	Not used	—	—
	Individual unit	Set temperature of indoor unit	61 to 88 [10 to 31]	°F
	Common	S/W version	Displays a S/W version number. Example: If it is a ver. 12.34, <div style="text-align: center;"> 0.5 s 0.5 s 2.0 s 12 →34 →□□ ↑—————┘ </div>	Code display
	Individual unit			
	Common	Not used	—	—
	Individual unit	LEV opening pulse (gear operated value)	0 to 2000	Pulse
	Common	S/W ROM check sum	0000 to FFFF Example: If it is 0BC9h, <div style="text-align: center;"> 0.5 s 0.5 s 2.0 s 0b →C9 →□□ ↑—————┘ </div>	Code display
	Individual unit			

*1 Refer to the <Table 1> for the appropriate setting for the function.

PHOTO: PAC-MKA53BC

→ : Indicates the visible parts in the photos/figures.

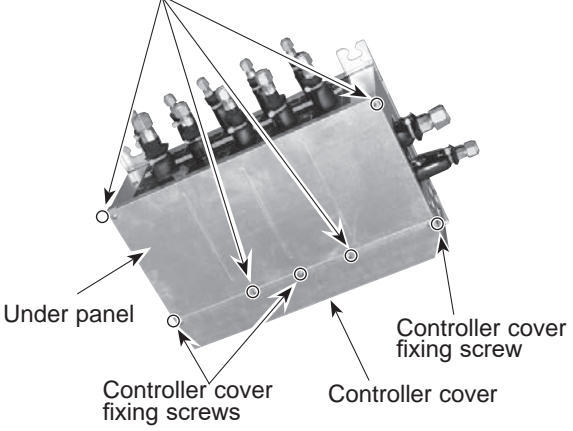
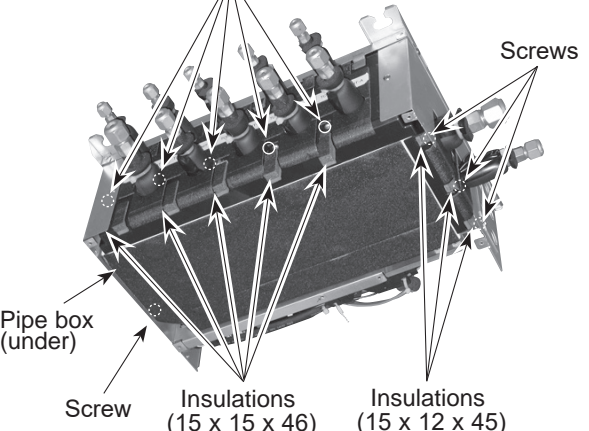
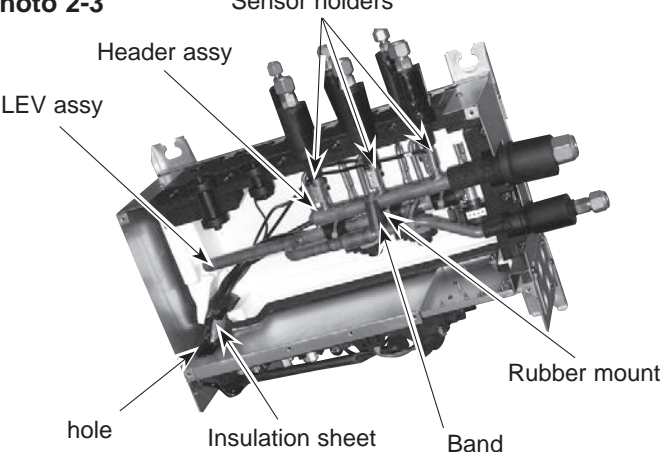
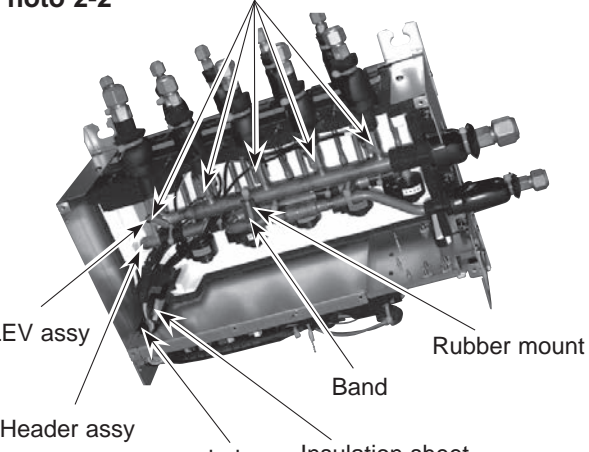
OPERATING PROCEDURE	PHOTOS/FIGURES
<p>1. Removing the controller cover and under panel</p> <p>(1) Remove 3 controller cover fixing screws (4 x 10) to detach the controller cover. (See Photo 1)</p> <p>(2) Remove 4 under panel fixing screws (4 x 10) to remove the under panel. (See Photo 1)</p>	<p>Photo 1</p> <p>Under panel fixing screws</p>  <p>Under panel</p> <p>Controller cover fixing screws</p> <p>Controller cover fixing screw</p> <p>Controller cover</p>
<p>2. Removing the thermistor (TH-A to E*)</p> <p>(1) Remove the controller cover. (See Photo 1)</p> <p>(2) Remove the under panel. (See Photo 1)</p> <p>(3) Remove 8 insulations, then remove 9 pipe box (under) fixing screws (4 x 10). (See Photo 2-1)</p> <p>(4) Pull out the thermistor(s), TH-A to E, from the sensor holders mounted on the gas pipe. (See Photo 2-2)</p> <p>(5) Loosen the insulation sheet which bundles the thermistor connectors.</p> <p>(6) Loosen the side clamps, then disconnect the connector(s) on the controller board.</p> <p>(7) Pull out the lead wire(s) through the hole to the controller board side.</p> <p>*TH-A to C for PAC-MKA3*BC. (See Photo 2-3)</p> <p>Notes:</p> <ol style="list-style-type: none"> 1. Attach the insulation sheet to the thermistor(s) and the lead wire(s) of LEV coil after replacing thermistor(s). 2. Install the pipe box not to twine the lead wire(s) and the pipe cover around the pipe box. 	<p>Photo 2-1</p> <p>Pipe box (under) fixing screws</p>  <p>Screws</p> <p>Pipe box (under)</p> <p>Screw</p> <p>Insulations (15 x 15 x 46)</p> <p>Insulations (15 x 12 x 45)</p>
<p>Photo 2-3</p>  <p>Sensor holders</p> <p>Header assy</p> <p>LEV assy</p> <p>Rubber mount</p> <p>hole</p> <p>Insulation sheet</p> <p>Band</p>	<p>Photo 2-2</p> <p>Sensor holders</p>  <p>LEV assy</p> <p>Rubber mount</p> <p>Band</p> <p>Header assy</p> <p>hole</p> <p>Insulation sheet</p>

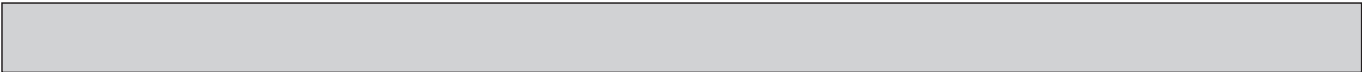

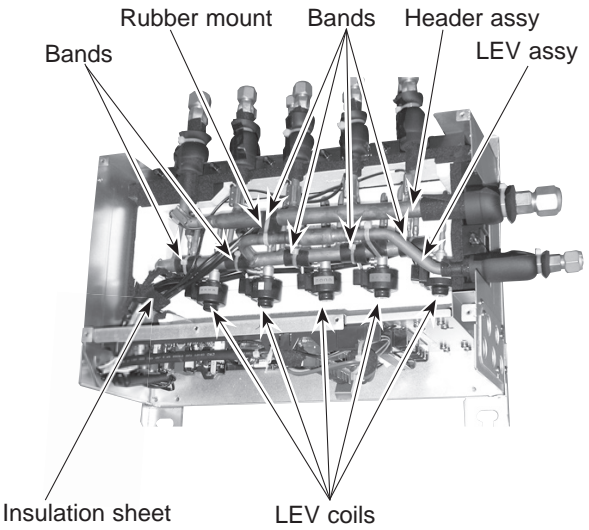
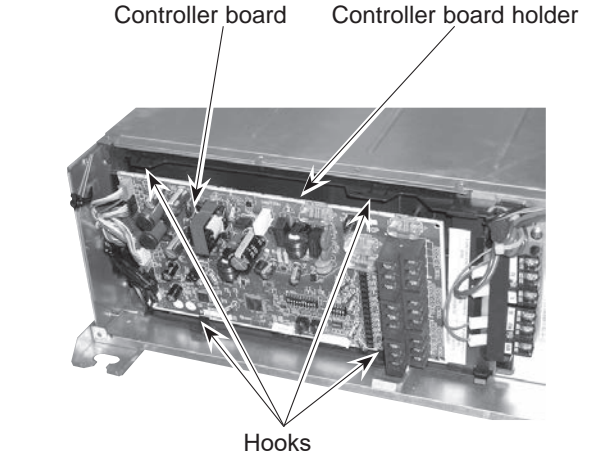
OPERATING PROCEDURE	PHOTOS/FIGURES
<p>3. Removing the LEV coil (LEV-A to E*)</p> <ol style="list-style-type: none">(1) Remove the controller cover. (See Photo 1)(2) Remove the under cover. (See Photo 1)(3) Remove 8 insulations, then remove 9 pipe cover fixing screws (4 x 10). (See Photo 2-1)(4) Cut the bands that fixes the lead wire, then pull out the LEV coil(s) (LEV-A to E*). (See Photo 3)(5) Loosen the insulation sheet which bundles the LEV lead wires.(6) Loosen the side clamps, then disconnect the connector(s) on the controller board.(7) Pull out the lead wire(s) through the hole to the pipe box side. (See Photo 2-2 or 2-3) <p>*LEV-A to C for PAC-MKA3*BC. (See Photo 2-3)</p> <p>Notes:</p> <ol style="list-style-type: none">1. Attach the insulation sheet to the thermistor(s) and the lead wire(s) of LEV coil after replacing thermistor(s).2. Install the pipe box not to twine the lead wire(s) and the pipe cover around the pipe box.	<p>Photo 3</p>  <p>Labels in Photo 3: Bands, Rubber mount, Bands, Header assy, LEV assy, Insulation sheet, LEV coils.</p>
<p>4. Removing the controller board</p> <ol style="list-style-type: none">(1) Remove the controller cover. (See Photo 1)(2) Loosen the side clamps, then disconnect the connectors on the controller board.(3) Pick an upper edge of the controller board, then pull forward. The controller board is fixed to the controller board holder with 4 hooks. (See Photo 4)(4) Remove the controller board from the controller board holder.	<p>Photo 4</p>  <p>Labels in Photo 4: Controller board, Controller board holder, Hooks.</p>

OPERATING PROCEDURE

5. Removing the LEV assy

- (1) Remove the controller cover. (See Photo 1)
- (2) Remove the under panel. (See Photo 1)
- (3) Remove 8 the insulations, then remove 9 pipe box (under fixing screws (4 x 10). (See Photo 2-1)
- (4) Loosen the side clamps, then disconnect the LEV and thermistor connectors on the controller board.
- (5) Remove the earth lead wires from the LEV assy.
- (6) Pull out the lead wires through the hole to the pipe box side.

<Removing the header assy>

- (7) Cut the band which fixes the header assy and LEV assy together, then remove the rubber mount. (See Photo 3)
- (8) Remove the header assy. (See Photo 3)

<Disassembling the pipe box>

- (9) Remove 2 side panel fixing screws (4 x 10). (See Photo 5-1)
- (10) Pull out the pipe box (top) and separate it from the side panel. (See Photo 5-2)
- (11) Turn the pipe box (top) upside down. (See Photo 5-3).
- (12) Remove 5 insulations, then remove 5 pipe box (top) fixing screws (4 x 10).
- (13) Turn the pipe box (top) upside down again, facing the pipe side up.
- (14) Separate the pipe box (center) from the pipe box (top). (See Photo 5-4.)
- (15) Remove the LEV assy.

<Pipe box cap only for PAC-MKA3*BC>

The pipe box caps are placed in 2 unused pipe holes between the pipe box top, center and under. (See Photo 5-5)

Notes:

1. Attach the insulation sheet to the thermistor(s) and the lead wire(s) of LEV coil after replacing thermistor(s).
2. Install the pipe box not to twine the lead wire(s) and the pipe cover around the pipe box.

Photo 5-4

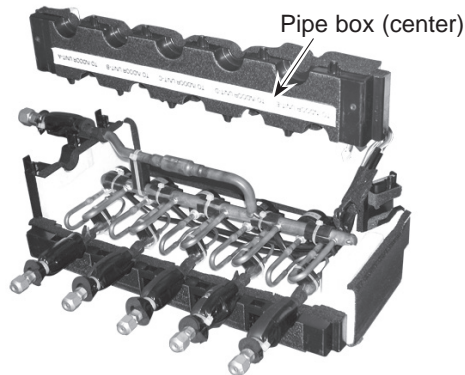
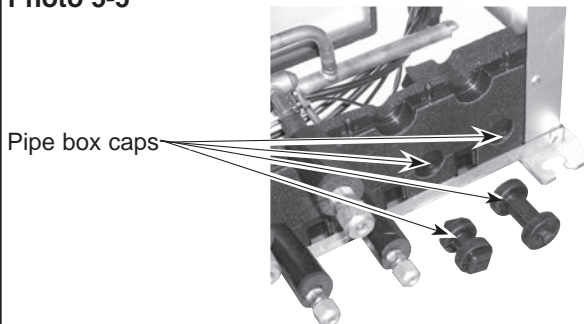

Photo 5-5



PHOTOS/FIGURES

Photo 5-1

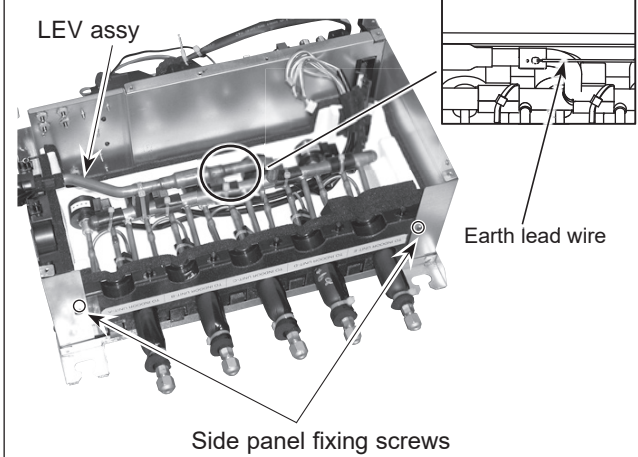

Photo 5-2

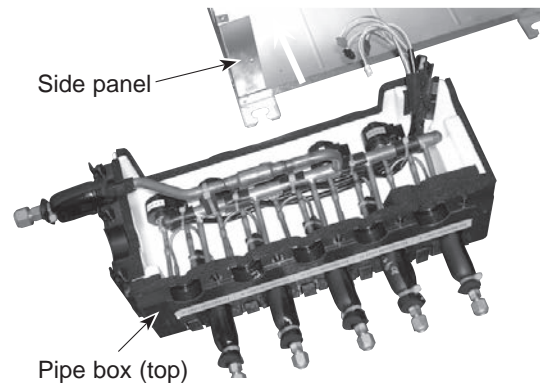
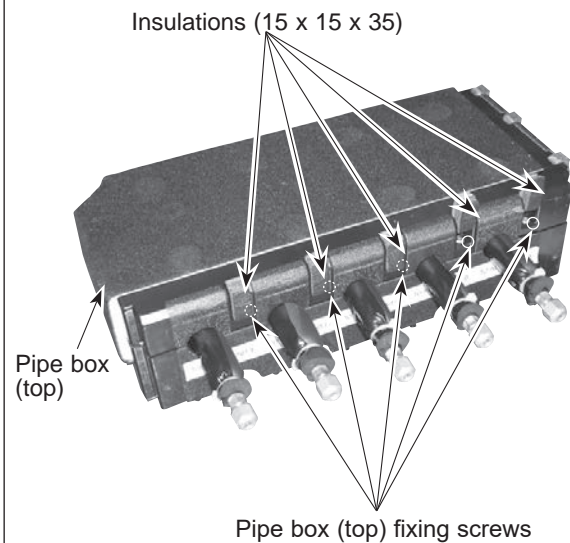

Photo 5-3





mitsubishi electric corporation

HEAD OFFICE: TOKYO BUILDING, 2-7-3, MARUNOUCHI, CHIYODA-KU, TOKYO100-8310, JAPAN
